

1. Identification of Proposed Project

X3T9.2/93-061r2

1.1 Title: Serial Storage Protocol (SSP)

1.2 Proposer

This project is proposed by the X3T9.2 Task Group. For additional information, information, please contact John B. Lohmeyer, X3T9.2 Chair, at NCR Corporation, 1635 Aeroplaza Dr., Colorado Springs, CO 80916, (Phone: 719-573-3362 FAX: 719-597-8225) or Dal Allan, X3T9.2 Vice-Chair at ENDL, 14426 Black Walnut Ct., Saratoga, CA 95070 (Phone: 408-867-6630 Fax: 408-867-2115) or John P. Scheible, IBM Corporation, Dept G46 Bldg 028, 5600 Cottle Road, San Jose, CA 95193, (Phone: 408-256-7275 Fax: 408-256-2254).

1.3 Date Submitted: October 1993

1.4 Project Type: Development

2. Justification of Proposed Standard or Technical Report

2.1 Needs

Now that SSA-PH has been approved as a new task group (X3T9.7), a SCSI protocol is needed that will operate over the SSA-PH interface. This proposal suggests that SCSI-3 be mapped to operate over the SSA-PH interface. This will allow SCSI to operate over the high performance SSA serial interface. It is key that most of the tremendous effort involved in SCSI be preserved in the port to SSA.

2.2 Recommended Scope of Standard or Technical Report

The proposed SSP standard shall preserve as much of SCSI as is practical, while maximizing the key benefits of SSA-PH including but not limited to high performance, high throughput, redundant pathing, dual port, RAID extensions, and serviceability features (hot plug).

Functions which will be considered for incorporation include:

- a) Definition of the packet format and addressing method.
- b) Mapping bus functions and messages to SSA.
- c) Support of the expanded addressing capability of SSA.
- d) Support for Dual Port and alternate pathing.
- e) Concurrent active I/O processes on the same or different devices.
- f) Support of out of order data transfers.
- g) Other capabilities which fit within the scope of the Serial Storage Architecture SCSI mapping layer that may be proposed during the development phase by the participants in the project.

2.3 Existing Practice in Area of Proposed Standard or Technical Report

Considerable work has been done in X3T9.2 on SCSI and in the private sector that will be used as the basis for this standard.

2.4 Expected Stability of Proposed Standard or Technical Report with Respect to Current and Potential Technological Advances

This standard is possible due to the latest technology advancements, and is expected to be viable for at least 10 years. The interface is extendable by advanced technology that will become commercially feasible within the lifetime of this standard.

3. Description of Proposed Project

3.1 Type of Document (Standard or Technical Report): Standard

3.2 Definition of Concepts and Special Terms (if any):

SSP is an acronym for Serial Storage Protocol. SSA is an acronym for Serial Storage Architecture. SSA-PH refers to the physical layer of SSA.

3.3 Expected Relationship with Approved X3 Reference Models (e.g., DBMS, OSI)

The SSP standard is for use in closed systems.

3.4 Recommended Program of Work

The following program of work is planned for the SSP standard:

- Solicit participation from members of the storage industry through X3T9.2 and X3T9.7 procedures and through press releases. Invite comments by end-user organizations and invite proposals from organizations that may have a contribution to a viable SSP standard.
- Develop a viable SSP standard.
- Prepare a draft standard based on proposals submitted and other information gathered during the initial investigation.
- Consider the results of SSP testing as may be available to the committee through the voluntary efforts of the various participants in X3T9 and its assigned task groups.
- Submit the draft proposed standard to X3 for further processing.

3.5 Resources - Individuals and Organizations Competent in Subject Matter

The current membership of X3T9 includes representatives from all parts of the computer industry from semiconductor chip manufacturers to large mainframe system manufacturers as well as Government agencies. Initial ground work has been done, and a poll taken of interested parties. A significant number of people in the industry have volunteered to participate and cooperate in the development of this proposed standard.

There are sufficient resources to complete the development of this standard without delaying work on other standards.

3.6 Recommended X3 Development Technical Committees (Existing or New)

It is recommended that the development work be done in the X3T9.2 task group.

3.7 Anticipated Frequency and Duration of Meetings

The proposed X3T9.2 meets 2 days bi-monthly. Specific task and ad hoc groups are called as may be required for 1 to 3 days between regular meetings, but their results are not binding.

3.8 Target Date for dpANS to X3 (Milestone 10): December 1994

3.9 Estimated Useful Life of Standard or Technical Report

It is anticipated that this standard will have a life of over 10 years.

4. Implementation Impacts

4.1 Impact on Existing User Practices and Investments

The proposed SSP standard will provide an evolutionary path to an higher performance serial interface and allow interface protocols that could preserve existing software (system device driver, device controller microcode) investment. It is likely that any isolated negative impacts would occur in any case through non-standard evolution or revolution.

4.2 Impact on Supplier Products and Support

The proposed SSP standard will provide an evolutionary path to an higher performance serial interface and allow interface protocols that could preserve existing software (system device driver, device controller microcode) investment. It is likely that any isolated negative impacts would occur in any case through non-standard evolution or revolution.

4.3 Techniques and Costs for Compliance Verification

The committee will consider the results of SSP testing as may be available to the committee through the voluntary efforts of the various participants in X3T9 and its assigned task group. With this method all costs are borne by the organizations of the various participants and have for the most part been mainly an adjunct of their normal development costs.

4.4 Legal Considerations

There are no known legal considerations. A call for patents will be made under milestone 7.

5. Closely Related Standards Activities

The proposed SSP standard provides a protocol for using SCSI-3 command sets on the Serial Storage Architecture physical interface (SSA-PH), which is being developed in X3T9.7 (see 5.2).

5.1 Existing Standards: none

5.2 X3 Standards Development Projects

The proposed SSP standard is part of the overall SCSI-3 family of standards:

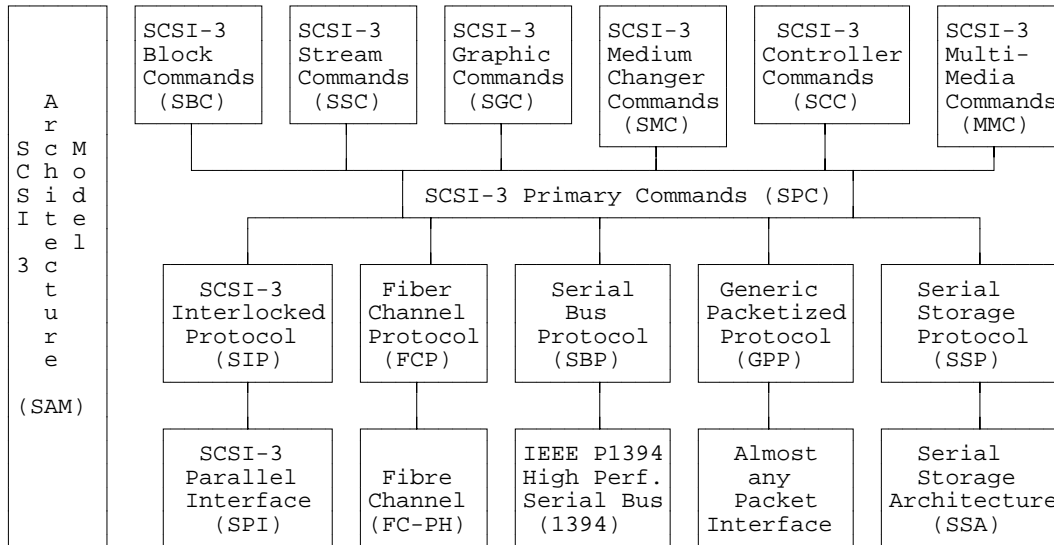

5.3 X3 Study Groups: none

5.4 Other Related Domestic Standards Efforts: none.

5.5 ISO Standards Development Projects

It is anticipated that this standard will be proposed to JTC1/SC25/WG4.

5.6 Other Related International Standards Development Projects: none.

5.7 Recommendations for Coordinating Liaison: none.

5.8 Recommendations for Close Liaison: X3T9.7.