

Date: Nov. 30, 1999

To: T10 Committee (SCSI)

From: George Penokie (IBM)

Subject: Comments resolution for SPI-3 Letter Ballot

## Comments Robert Frey of Advansys:

### SPI-3: 1.1) Comment #1:

Recommend additional information units phase sequence figure The following phase diagrams are included in the current revision:

13.1 Phase sequences for physical reconnection and selection using attention condition with information unit transfers disabled

13.2 Phase sequences for selection without using attention condition with information unit transfers disabled

13.3 Phase sequences for selection without using attention condition/ physical reconnection with information unit transfers disabled I recommend another phase sequence figure:

13.4 Phase sequences for selection using attention condition with information unit transfers enabled Without a 13.4 phase sequence figure the text of section 10.3.1.1.2 is not represented in SPI-3 Section 13. There is value to having Section 13 include all prescribed/legal sequences, which is what I think it is attempting to do.

Text from 10.3.1.1.2:

10.3.1 Selection

10.3.1.1 Selection using attention condition

10.3.1.1.2 Information unit transfers enabled

If information unit transfers are enabled for the connecting initiator the target shall proceed to MESSAGE OUT phase.

**Accept: Section 13.4 added**

### SPI-3: 2.2) Comment #2:

Data group transfer wide residual reporting and restriction

Proposal A:

Add text to 4.8.2.1 that for DT DATA IN phase will state the correct procedure for reporting wide residual and for DT DATA OUT phase require intermediate data fields to be an even number of bytes.

Proposed wide residual reporting clarification text and restriction to be added to 4.8.2.1 Data group transfers:

During DT DATA IN phase if the number of bytes in a data field is not a multiple of two bytes, then after sending the pad and pCRC fields the target device shall change to MESSAGE IN phase and send an IGNORE WIDE RESIDUE 16.2.3 message with the NUMBER OF BYTES TO IGNORE field set to 01h.

During DT DATA OUT phase if a target requests a pCRC field prior to the last data field of a command, the initiator shall transmit an even number of bytes in that data field.

The first paragraph will lower the probability of incorrect initiator and target implementations.. The second paragraph is needed because there is no mechanism defined for an initiator to indicate an intermediate wide residual to a target. A target is only able to infer a wide residual at the very end of a wide transfer transfer by recalling whether the command transfer length.

Proposal B:

Add a requirement that all intermediate data fields (pCRC interval) be a multiple of two bytes. This would be consistent with IU transfers (4.8.2.2) which require the iuCRC interval to be an even number of bytes.

**Accept: Proposal A wording placed into section 4.8.3.1**

**SPI-3: 3.3) Comment #3:**

Typo

4.7, paragraph two, 2nd sentence "2X depending on the whether" should be "2X depending on whether".

**Accept**

**Comments from BILL MABLE of Amphenol Interconnect:**

**SPI-3: 4.1)**

I was unable to get onto the reflector but the reason we are voting no pertains to the comments submitted by Bill Ham pertaining to the technical changes. I will try and get you the file name for the comments that were submitted by Bill Ham.

**See comments 33.1 through 96.64.**

**Letter ballot comments on SPI-3 r10 from Bill Galloway of BREA Technologies, Inc.**

KEY: (E) = Editorial; (T) = Technical;

**SPI-3: 5.1) 1) (T) Page 87, section 9.2.20:**

I believe the next to last sentence in 99-169r1 was meant to apply to phases in both directions. "A QAS capable initiator shall assert ACK for a minimum 50ns period." The description of output phases does not agree with 99-169r1. Replace entire section with following:

The minimum time a QAS-capable initiator shall insure that REQ, ACK are asserted, and that DATA is valid during command, message and status phases.

Other changes are in individual phase descriptions.

**Accept**

**SPI-3: 6.2) 2) (T) Page 101, section 10.2.2.1 clause c):**

Move "and if there is no attention condition" from ACK true to ACK false.

**Accept**

**SPI-3: 7.3) 3) (T) Page 102, section 10.3.1.1.2, paragraph 1:**

With SCSI today, all hot plug or independent reset events are handled gracefully by negotiation. If either the initiator or target underwent a reset event without the other one knowing it, the negotiated parameters were inconsistent. This inconsistency was handled gracefully on the first command because the device that was reset initiates a negotiation and that first command goes to completion. No commands were allowed to progress far enough without the negotiation that they had to be aborted.

The current paragraph does not allow for the graceful negotiation. The non-PPR message should not be rejected. The target should initiate a PPR negotiation if the initiator does not. If after the PPR, information units are turned off, then the command can continue normally with the current I\_T\_L or I\_T\_L\_Q nexus. In addition, the first message should not be rejected if it is a TARGET RESET.

**Accept: changed to:**

**If information unit transfers are enabled for the connecting initiator the target shall proceed to a MESSAGE OUT phase. On detecting the MESSAGE OUT phase the initiator shall begin a PPR negotiation (see 16.3.10). On completion of the PPR negotiation the target shall proceed to a BUS FREE phase. If the first message received by the target during the MESSAGE OUT phase is not a task management message or a PPR message the target shall change to a MESSAGE IN phase and issue a MESSAGE REJECT message followed by a PPR message.**

**SPI-3: 8.4) 4) (T) Page 103, section 10.3.1.2, paragraph 9:**

Same general comment as above.

Why can't the target try to initiate a PPR negotiation before going to command phase. The initiator can always reject the PPR and let the target continue with the command if that is what it wants. If the PPR is successful then there would be no aborted commands.

**Pending: GOP-Needs to be discussed**

**SPI-3: 9.5) 5) (E) Page 108, section 10.5.2.2.1.1, paragraph 1:**

Sentence is confusing, replace with:

The initiator shall not negate the ACK for the last byte of the last iuCRC in an information unit until the entire information unit has been verified and any required attention condition has been established.

**Accept**

**SPI-3: 10.6) 6) (T) Page 108, section 10.5.2.2.1.1, paragraph 2:**

Allow the initiator to send either ABORT TASK or INITIATOR DETECTED ERROR. The initiator knows what error it got; it does not need the target to tell it in a subsequent status (which may have an error also). A target cannot assume (and log) a CRC error when it receives an INITIATOR DETECTED MESSAGE because the definition of the message says that an initiator could send it for reasons unrelated to any previous SCSI activity.

**Reject: GOP- pending further discussion**

**SPI-3: 11.7) 7) (T) Page 109, section 10.5.2.2.1.1, paragraph 3:**

There is no need to tie an error to a specific iuCRC interval in an information unit. Change “before the iuCRC is acknowledged” to before the last iuCRC of the information unit is acknowledged”.

**Accept**

**SPI-3: 12.8) 8) (E) Page 109, section 10.5.2.2.2, paragraph 1:**

Sentence is confusing, replace with:

When the target is transferring consecutive data groups, it shall not transition the REQ signal while the P\_CRCA signal is asserted for the current data group until the initiator has acknowledged the entire previous data group.

**Accept**

**SPI-3: 13.9) 9) (E) Page 111, section 10.5.2.2.2.1, paragraph 8:**

Since this could be an improperly formatted data group change “before the last transfer of the pCRC field” to “before the last transfer of the data group”.

**Accept**

**SPI-3: 14.10) 10) (T) Page 111, section 10.5.2.2.2.1, paragraph 8:**

Allow the initiator to send either ABORT TASK or INITIATOR DETECTED ERROR. The initiator knows what error it got; it does not need the target to tell it in a subsequent status (which may have an error also). A target cannot assume (and log) a CRC error when it receives an INITIATOR DETECTED MESSAGE because the definition of the message says that an initiator could send it for reasons unrelated to any previous SCSI activity.

**Reject - GOP Pending discussion**

**SPI-3: 15.11) 11) (T) Page 114, section 10.6, paragraph 3:**

Replace paragraph with following:

A QAS-capable initiator shall wait a minimum of a QAS non-DATA phase REQ (ACK) period to assert ACK after detecting the assertion of REQ.

A QAS-capable initiator shall assert ACK for a minimum of a QAS non-DATA phase REQ (ACK) period and shall keep the command data valid until the negation of ACK.

**Accept**

**SPI-3: 16.12) 12) (T) Page 115, section 10.8, paragraph 3:**

Replace paragraph with following:

A QAS-capable initiator shall wait a minimum of a QAS non-DATA phase REQ (ACK) period to assert ACK after detecting the assertion of REQ.

A QAS-capable initiator shall assert ACK for a minimum of a QAS non-DATA phase REQ (ACK) period.

**Accept**

**SPI-3: 17.13) 13) (T) Page 115, section 10.8.1, paragraph 1:**

Allow the initiator to send either ABORT TASK or INITIATOR DETECTED ERROR. The initiator knows what error it got; it does not need the target to tell it in a subsequent status (which may have an error also). A target cannot assume (and log) a parity error when it receives an INITIATOR DETECTED MESSAGE because the definition of the message says that an initiator could send it for reasons unrelated to any previous SCSI activity.

Pending **GOP**- Further discussion needed

**SPI-3: 18.14) 14) (T) Page 115, section 10.9.1, paragraph 3:**

Same as 10.8 above

**Accept**

**SPI-3: 19.15) 15) (T) Page 115, section 10.9.2, paragraph 3 and 4:**

Replace paragraph with following:

A QAS-capable initiator shall wait a minimum of a QAS non-DATA phase REQ (ACK) period to assert ACK after detecting the assertion of REQ.

A QAS-capable initiator shall assert ACK for a minimum of a QAS non-DATA phase REQ (ACK) period and shall keep the message data valid until the negation of ACK.

**Accept**

**SPI-3: 20.16) 16) (E) Page 116, section 10.10 clause b):**

I/O is not the only signal that causes a direction change. The C/D line can cause the direction of the P\_CRCA line to change.

**Accept: Add the following in the a,b,c list:**

The P\_CRCA signal direction may switch direction while the DATA BUS does not (e.g., changing from COMMAND phase to DT DATA OUT phase). When switching the P\_CRCA signal direction from out (initiator driving) to in (target driving), the target shall delay driving the P\_CRCA by at least a data release delay plus a bus settle delay after negating the C/D signal and the initiator shall release the P\_CRCA signal no later than a data release delay after the transition of the C/D signal to false. When switching the P\_CRCA signal direction from in (target driving) to out (initiator driving), the target shall release the P\_CRCA signal no later than a system deskew delay after asserting the C/D signal. The initiator shall negate the P\_CRCA signal no sooner than a system deskew delay after the detection of the assertion of the C/D signal.

**SPI-3: 21.17) 17) (E) Page 124, figure 52:**

Since QAS was removed from this figure there should be no arrow from arbitration to bus free.

**Accept**

**SPI-3: 22.18) 18) (T) Page 132, section 14.2.1, paragraph 3:**

Change "TASK SET FULL" to "TASK SET FULL or BUSY as specified in SAM-2"

**Accept:** Removed 'TASK SET FULL' and replaced with a reference to SAM-2.

**SPI-3: 23.19) 19) (T) Page 132, section 14.2.1:**

Require TASK MANAGEMENT FLAGS to be zero for Multiple Command type.

**Accept:** Added the words 'regardless of command type' into paragraph 3.

**SPI-3: 24.20) 20) (T) Page 140, section 14.2.5, paragraph 8:**

Status will be good for packetized failures.

**Accept:** Removed 'with a status that is GOOD' in paragraph 8.

**SPI-3: 25.21) 21) (E) Page 146, section 16.2.2, paragraph 5, clause b)**

Grammar, change "is completed" to "can be completed".

**Accept**

**SPI-3: 26.22) 22) (E) Page 147, section 16.2.3, paragraph 2:**

32-bit obsolete, Change "residual byte(s) contain(s)" to "residual byte contains".

**Accept**

**SPI-3: 27.23) 23) (E) Page 154, table 57, row 3:**

32-bit obsolete, no REJECT, Replace with:

TRANSFER WIDTH equal to one | Sixteen-bit data

**Accept: Changed to**

TRANSFER WIDTH EXPONENT equal to 1	16-bit data
------------------------------------	-------------

**SPI-3: 28.24) 24) (E) Page 161, table 62, row 1:**

32-bit obsolete, no REJECT, Replace with:

TRANSFER WIDTH equal to one | Sixteen-bit data

**Accept: Changed to**

TRANSFER WIDTH EXPONENT equal to 1	16-bit data
------------------------------------	-------------

**SPI-3: 29.25) 25) (T) Page 192, Annex B:**

Replace entire annex with:

## Annex A

### A.1 Model

Implementation of the SCSI bus fairness is optional, however, if implemented, the SCSI bus fairness protocol shall conform to this annex.

A SCSI device determines “fairness” by monitoring prior arbitration attempts by other SCSI devices. It shall postpone arbitration for itself until all lower priority SCSI devices that previously lost arbitration either win a subsequent arbitration or discontinue their arbitration attempts (as in the case where the initiator aborted an outstanding command thus removing the need to re-arbitrate).

When a SCSI device does not need to arbitrate for the SCSI bus, it shall monitor the arbitration attempts of the other SCSI devices and refresh the fairness register with the SCSI IDs of any lower priority SCSI devices that lost arbitration.

Whenever a requirement for arbitration arises, a SCSI device shall first check to see if its fairness register is clear. If it is clear, then no lower priority SCSI device has attempted and lost the previous arbitration and therefore, this SCSI device may now participate in arbitration. If the fairness register is not clear, the SCSI device shall postpone arbitration until all lower priority SCSI IDs have been cleared from the fairness register. Lower SCSI IDs are cleared as those SCSI devices win arbitration. SCSI IDs shall also be cleared if a SCSI device discontinues arbitration (e.g., as a result of an ABORT TASK message, ABORT TASK SET message, CLEAR TASK SET message, TARGET RESET message, hard reset).

The fairness register may be refreshed, updated or cleared. The fairness register is refreshed by copying the SCSI IDs of any lower priority SCSI devices that lost arbitration into the fairness register. A refresh of the fairness register completely replaces the previous contents of the fairness register. The fairness register is updated by removing the SCSI IDs of any lower priority devices that win arbitration or discontinue arbitration. The fairness register is cleared by setting all of its bits to zero. SCSI IDs may only be added to the fairness register by a refresh but may be subtracted by a refresh, update or clear.

Since the fairness register is only refreshed when a SCSI device is not arbitrating for itself, the fairness register is effectively frozen by a SCSI device prior to a requirement for its own arbitration arising. Therefore, only those lower priority SCSI devices latched into the fairness register at that time arbitrate ahead of this SCSI device. Other lower priority SCSI devices that were not latched shall not be added to the fairness register until this SCSI device has successfully arbitrated.

Arbitration fairness in targets is controlled with the disconnect-reconnect mode page (see 18.1.1).

### A.2 Determining fairness by monitoring prior bus activity

#### A.2.1 Fairness for normal arbitration method

For the normal arbitration method this standard requires that within a bus set delay of when BSY was first asserted, the SCSI ID of all arbitrating SCSI devices shall appear on the bus. A SCSI device shall sample the bus after this time, to determine which SCSI devices are attempting arbitration, which SCSI device won, and which SCSI devices lost. Since the lower priority SCSI IDs begin to disappear after an arbitration delay from the assertion of BSY, the data bus must be sampled after a bus set delay but before an arbitration delay.

NOTE 38 - For ease of implementation, the sample window may begin when BSY is asserted to begin arbitration and extending until SEL is asserted. Sampling of the bus during this time should occur at a high enough rate to ensure multiple samples within this window.

## A.2.2 Fairness for QAS

For QAS, after detection of a valid QAS REQUEST message, this standard requires that between 1000 nsec (QAS arbitration delay) and 1490 nsec (QAS arbitration delay+bus settle delay+2 deskew delays) after detection of the MSG, C/D, and I/O signals being false the SCSI ID for all arbitrating SCSI devices shall appear on the bus. The SCSI device shall sample the bus during this time, to determine which SCSI devices are attempting arbitration, which SCSI device won, and which SCSI devices lost. Since the lower priority SCSI IDs begin to disappear at 1490 nsec, a continuous sampling of the data bus between 1000 nsec and 1490 nsec is required.

## A.3 Fairness algorithm

A SCSI device shall be in one of three fairness modes. A SCSI device shall be in Fair Wait mode if it is waiting for a clear fairness register to participate in arbitration. A SCSI device shall be in the Fair Participate mode if it is participating in arbitration. A SCSI device shall be in the Fair Idle mode for all other conditions. A SCSI device shall enter the Fair Idle mode after any reset event. A SCSI device shall implement a lockout delay to prevent devices that stop arbitrating from causing deadlock.

### A.3.1 Fairness Idle mode

A SCSI device shall be in Fair Idle mode if it does not need to arbitrate for the SCSI bus. The fairness register shall be refreshed during each arbitration while in the Fair Idle mode. The fairness register will then contain the SCSI IDs of any lower priority arbitration losers. A SCSI device shall transition to the Fair Wait mode if it needs to arbitrate and the fairness register is not clear. A SCSI device shall transition to the Fair Participate mode if it needs to arbitrate and the fairness register is clear.

### A.3.2 Fair Wait mode

A SCSI device shall be in Fair Wait mode if it needs to arbitrate for the SCSI bus, but the fairness register is not clear. The fairness register shall be updated during each arbitration while in the Fair Wait mode. The updates subtract out arbitration winners and non-participants. The updates shall not add any new arbitration participants. A SCSI device transitions to the Fair Participate mode once all of the bits in the fairness register have been cleared.

### A.3.3 Fair Participate mode

A SCSI device shall be in Fair Participate mode if it is participating in arbitration. A SCSI device can only be in Fair Participate mode if the fairness register is clear. If the SCSI device wins the arbitration it shall refresh the fairness register. If the SCSI device loses arbitration it shall keep the fairness register clear and remain in the Fair Participate mode.

### A.3.4 Lockout delay

A SCSI device shall implement a Lockout delay to prevent deadlock during normal arbitration. The lockout delay shall be at least 2us and shall start once bus free has been detected. Each SCSI device shall clear its fairness register if no SCSI device starts arbitration before the lockout delay expires.

NOTE 39 - The lockout delay is required because all the SCSI devices may be waiting for other SCSI devices to start the arbitration process. Although rare, the following example is valid and may occur. Assume an initiator at SCSI ID 7 that starts tasks in SCSI devices at SCSI IDs 0, 2, and 4. After a while, SCSI devices 0 and 2 begin arbitration, 2 wins and device 0 is recorded in the fairness register of all SCSI devices. Assume at the next arbitration, SCSI device 4 would like to arbitrate but does not because of fairness to SCSI device 0. However, this second arbitration is won by the initiator at SCSI device address 7 for purposes of ABORTING the task in SCSI device address 0. The result is that the initiator is waiting for SCSI device 4, SCSI device 4 is waiting in fairness for SCSI device 0 and SCSI device 0 no longer needs to arbitrate since its task has been aborted. When the lockout delay expires, SCSI devices 7 or 4 may begin arbitration.



NOTE 40 – The lockout delay is not required for QAS arbitration because the bus will go bus free after a QAS arbitration delay. The fairness register will be cleared because of mixed arbitration (B.3.4).

### **A.3.5 Mixed arbitration**

The fairness register shall be cleared by all SCSI devices that detect a change in arbitration mode. If the previous arbitration was an QAS arbitration then the fairness register shall be cleared if bus free is detected. If the previous arbitration was a normal arbitration then all devices that detect the QAS arbitration shall clear the fairness register.

NOTE 41 – Some legacy devices may not detect the QAS arbitration and may not clear their fairness register.

### **A.4 Initiator fairness recommendations**

It is generally desirable for the initiator to be the highest priority SCSI device on the bus. In this way, the initiator is guaranteed to win arbitration and may overlap commands to multiple SCSI devices. To maintain this capability, the initiator should not implement fairness towards lower level targets.

In the case of a multi-initiator system, it would again be desirable for the initiators to be the highest priority SCSI devices. However, in order to implement fairness between them, the higher priority initiator could implement fairness with the lower priority initiators only. This would require a second register in which a bit is enabled for each lower priority SCSI device to which a higher priority SCSI device shall be fair.

## **Comments from Ian Morrell of Circuit Assembly Corp.:**

### **SPI-3: 30.1)**

I incorporate by reference the "comments against SPI 3 rev 10, Section 6 and Annex E.zip."

See comments 33.1 through 96.64.

## **Comments from Neil T. Wanamaker of Crossroads Systems, Inc.:**

### **SPI-3: 31.1)**

(T) 10.5.2.2.1.1., 10.5.2.2.1.2. Mandating a check condition in these cases seems a retrograde step.

Pending **GOP** :See comments 10.6 and 14.10.

## **Comments from Zane Daggett of Hitachi Cable Manchester, Inc:**

### **SPI-3: 32.1)**

61 comments have been submitted in a document uploaded to the ftp site entitled "comments against SPI-3 rev 10 section 6 and annex E.zip". This document should serve as my reasoning for voting no on this ballot.

If this method is not acceptable please contact me at 603-661-3972. I did not paste these comments here because they include many graphics.

See comments 33.1 through 96.64.

## Compaq Comments against SPI-3 rev 10

### **SPI-3: 33.1) technical**

Section 6.3.1 Change:

The requirements in this clause apply to uniform cable media. Uniform media is media that is not designed to be non-uniform for the purposes of enabling connector attachment. These non-uniformities (e.g., a planar section created for connector attachment within a normally round cable media) is considered to be part of a cable assembly or harness whose performance is affected by the attached (sometimes unused) connectors as well as by the non-uniformity in the media.

To:

The requirements in this clause apply to uniform cable media. Non-uniform media is media that contains dissimilar sections for purposes of enabling connector attachment.

Non-uniformities (for example a planar section created for connector attachment) are considered to be part of a cable assembly or harness whose performance is affected by the attached (sometimes unused) connectors as well as by the non-uniformity in the media.

Implementors using non-uniform media may construct special uniform test media using manufacturing processes similar to that used for the non-uniform media for purposes of measuring the properties of the media between the connector attachment areas (e.g. the twisted regions in a twisted/flat planar construction).

For length dependent parameters both total and per unit length requirements are specified. This ensures performance compliance when concatenating cables in the same SCSI bus segment. Implementors have the practical option to use only the total requirements and to loosen the per unit length requirements in non-concatenated applications; however, this practice will create non conforming cables. Any cable media not meeting the per unit length requirements shall be labeled in a manner indicating that it is not suitable for use in cable assemblies that might be used in a concatenated manner.

**Accept with some editorial wording changes**

### **SPI-3: 34.2) editorial**

The term "flat" needs to be replaced with the word "planar" in all usage that refers to the physical construction of cable media except in the cases where clarifying of the meaning of the word "flat" in the context of cable media. (This change is needed to avoid confusion between unbalanced planar, the usual "flat" construction, and balanced planar, the twisted flat construction).

**Reject: This request is not specific enough for the editor to understand. Changing flat to planar seems to create terms that would not be recognizable by people reading the standard.**

### **SPI-3: 35.3) technical**

Remove Table 9.: recommended minimum conductor size.

(information is now contained in new table 12)

**Accept**

**SPI-3: 36.4) technical**

Change Table 10 to:

Cable construction	Local SE transmission line impedance **		Local DIFF transmission line impedance **	
	Min	Max	Min	Max
All	84 (78*)	96	110	135
All values are measured by time domain reflectometry * If SCSI loads attached to the cable media are separated by more than 1.0 m use the value of 78 Ohms ** Ideally one design will meet both SE and DIFF criteria Lower impedance values may be desirable when attaching directly to a backplane or other heavily loaded environments				

**Accept with some editorial wording changes**

**SPI-3: 37.5) technical**

Change:

6.3.4 Extended distance transmission line impedance

The swept frequency (extended distance) differential impedance limits shall be a maximum peak to peak variation of 30 ohms over the frequency range 1 MHz to 1 GHz on a 30 meter cable.

To:

6.3.4 Extended distance transmission line impedance

Swept frequency (extended distance) differential impedance limits: max peak to peak variation of 60 ohms over the frequency range 30 MHz to 600 MHz on a 30 meter cable.

**Accept with some editorial wording changes**

**SPI-3: 38.6) technical**

6.3.8 SE attenuation

Change from:

The maximum sine wave signal attenuation shall be 0,095 dB maximum per meter at 5 MHz, measured differentially or a maximum sine wave signal attenuation of 1,41 dB at 5 MHz for the entire bus measured differentially.

To:

SE attenuation requirements are not separately specified. SE attenuation requirements are indirectly specified through the differential requirements in section 6.3.9.

**Accept**

**SPI-3: 39.7) technical**

Change Table 12 to:

Table 12 - Attenuation requirements for SCSI cable media

Distance between SCSI bus terminators (meters)	Attenuation per meter max (dB) @ 200 MHz	Attenuation of length equivalent to terminator to terminator distance max (dB) @ 200 MHz	Distances are consistent with these minimum size conductors when used with high quality dielectrics:	Notes:
0 to 9	0.63	6	32 AWG solid/ 30 AWG stranded	multiple loads allowed
0 to 12	0.48	6	30 AWG solid/ 28 AWG stranded	multiple loads allowed
>12 to 25	0.48	12	30 AWG solid/ 28 AWG stranded	point to point only
Both the per meter and the length equivalent to the terminator to terminator spacing requirements shall be simultaneously met				

**Accept**

**SPI-3: 40.8) technical**

Change note 17 to read as follows:

NOTE 17 - SCSI devices connected with a maximum length SE A cable (table 3) are not able to meet the source current requirements in table 27 unless the TERMPWR conductor size is 0,080 98 mm 2 (28 AWG) minimum because the SE A cable contains only one TERMPWR line.

**Accept**

**SPI-3: 41.9) technical**

Change Table 11 to include the requirement of minimum as well as maximum values of capacitance and rewording of the dielectric constant requirements. The contents of table 11 should be:

Capacitance limits: SE 30 min to 66 pF/m max at 100 kHz and 1 MHz  
DIFF 26 min to 46 pF/m max at 100 kHz and 1 MHz

**Accept**

**SPI-3: 42.10) technical**

In 6.3.5

Change:

To calculate the allowable dielectric constant variation between 100 kHz and 1 GHz the maximum dielectric constant in the frequency range minus the minimum dielectric constant in the frequency range shall be less than 5% of the maximum dielectric constant in the frequency range.

To:

Dielectric constant variation in the material forming the insulation directly in contact with the conductors in the cable media between 300 kHz and 600 MHz: max dielectric constant in the frequency range divided by the min dielectric constant in the frequency range is less than 1.10.

**Accept: Reworded as: The dielectric constant variation in the material forming the insulation directly in contact with the conductors in the cable media between 300 kHz and 600 MHz shall be the less than 1,10 when the maximum dielectric constant in the frequency range divided by the minimum dielectric constant in the frequency range.**

**SPI-3: 43.11) technical**

Change 6.3.6 to:

SE propagation time requirements are not separately specified. SE propagation time requirements are indirectly specified through the differential requirements in section 6.3.7.

**Accept**

**SPI-3: 44.12) technical**

Section 6.2

Change:

Interconnection of SCSI devices by means other than cables is allowed (e.g., by backplanes using printed wiring boards) (see annex J). Detailed descriptions of these other means are not part of this standard; however, they are subject to the electrical characteristics presented in this standard. Examples of these electrical characteristics are:

- a) transmission line impedance (see 6.3);
- b) propagation delay (see 6.3);
- c) cumulative length (see 6.6 and 6.7); and
- d) signal attenuation (see 6.3).

To:

Interconnection of SCSI devices by means other than cables is allowed (e.g., by backplanes using printed wiring boards) (see annex J). Detailed descriptions of these other means are not part of this standard; however, they are subject to the electrical requirements in sections 6.3.

**Accept**

**SPI-3: 45.13) editorial**

Change:

NOTE 6 - Use of non-twisted flat cables causes cross-talk problems.

To:

NOTE 6 - Use of unbalanced media such as planar untwisted construction typically produces higher cross talk than balanced constructions but may be used if all performance requirements are met.

**Accept with some wording changes**

**SPI-3: 46.14) Technical**

Table 15

Change:

Note: Media capacitance with no SCSI devices attached measured between a signal conductor and ground when all other conductors in the path are connected to ground.

To:

Note: SE media capacitance with no SCSI devices attached measured per Annex E.

**Accept**

**SPI-3: 47.15) Technical**

Annex E-1

Change

This annex defines the electrical performance requirements for shielded and unshielded cable media and specifies the details of a measurement methodology to minimize the error between measurements executed in different laboratories.

Several parameters are required to specify the electrical requirements:

To:

This annex defines the electrical measurement methodology requirements to be used for both shielded and unshielded cable media. These methods are required to minimize the error between measurements executed in different laboratories.

The methodologies are specified to extract parameters in each of the following performance requirements:

**Accept**

**SPI-3: 48.16) technical**

Annex E-1

Change: This annex also specifies methods for testing for these parameters. Table E.1 summarizes the testing requirements.

To: Table E.1 summarizes the measurement methodology requirements.

**Accept**

**SPI-3: 49.17) editorial**

Remove the wording just before E-2: The test methods defined in this annex may or may not be applicable to complete SCSI bus segment performance. This annex does not address performance other than that of media designed to be uniform.

**Accept**

**SPI-3: 50.18) technical**

Change:

## E.2.1.2.2 Measurement system (with test fixture) calibration

Connect the 50 Ω cable to the test fixture. In place of “B” in figure E.1, connect a 100 Ω 0,1% (preferred) low inductance chip resistor. Use an unfiltered trace and the TDR cursors to measure the resistance value, R100, approximately 4 ns (displayed) after the resistor discontinuity. See figure E.2.

In a similar manner, in place of “B” in figure E.1, connect a 50 Ω 0,1% (preferred) low inductance chip resistor. Use an unfiltered trace and use the TDR cursors to measure the resistance value, R50, approximately 4 ns (displayed) after the resistor discontinuity.

To:

## E.2.1.2.2 Measurement system (with test fixture) calibration

Connect the 50 Ω cables to the test fixture. In place of “B” in figure E.1, connect a 100 Ω ±0,1% (preferred) low inductance chip resistor (IMS style TPI-1206 or equivalent). Use an unfiltered trace and the TDR cursors to measure the resistance value, R100, approximately 4 ns (displayed) after the resistor discontinuity. See figure E.2.

In a similar manner, in place of “B” in figure E.1, connect a 75Ω ± 0,1% (preferred) low inductance chip resistor. Use an unfiltered trace and use the TDR cursors to measure the resistance value, R75, approximately 4 ns (displayed) after the resistor discontinuity.

**Accept****SPI-3: 51.19) technical**

Immediately before sections E.2.1.2.3

Change:

Subtract R50 from R100 producing Delta R.

Correction factor for vertical scale and cursor readings = (Delta R) / 50

To:

For R100 and R75 the equation for determining the corrected (actual) impedance is:

$$Z_{corrected} = 25(4 \times X_1 - 3 \times X_2 - Z_{measured}) / (X_1 - X_2)$$

Where:

X<sub>1</sub> is the measured value using the 75Ω resistorX<sub>2</sub> is the measured value using the 100Ω resistor**Accept: The above equation is indeterminate. The editor used the following interpretation:**

$$Z_{corrected} = \frac{25 \times (((4 \times X_1) - (3 \times X_2)) - Z_{mesasured})}{X_1 - X_2}$$

**SPI-3: 52.20) technical**

In E.2.1.3 change:

- f) With the filter turned on to 3ns connect the DUT.
- g) DUT shall be suspended in air. No metallic supports should be used.
- h) Set the TDR cursor to measure minimum, mean, and maximum ohms with cursors set on the trace as it crosses the 5<sup>th</sup> and 6<sup>th</sup> times divisions.

To:

- f) With the rise time filter adjusted to achieve 3ns connect the DUT.
- g) Note: unshielded DUT's shall be suspended in air. No metallic supports should be used.
- h) Set the TDR cursor to measure minimum and maximum ohms with cursors set on the trace as it crosses the 5<sup>th</sup> and 6<sup>th</sup> times divisions.

**Accept**

### **SPI-3: 53.21) technical**

change:

#### E.2.2.2.3 Measurement system (with test fixture) calibration

Connect the 50  $\Omega$  cable to the test fixture. In place of "B" in Figure E.1, connect a 100 $\Omega$   $\pm$ 0,1% (preferred) low inductance chip resistor across the pair. Use a differential unfiltered trace and use TDR cursors to measure the resistance value, R100, approximately 4 ns (displayed) after the resistor discontinuity. See figure E.2. The method shown in figure E.2 applies to differential except a 100  $\Omega$  level from the test fixture will be seen and differential signals are displayed.

In a similar manner, in place of "B" in figure E.1, connect a 50 $\Omega$   $\pm$ 0,1% (preferred) low inductance chip resistor across the pair. Use a differential unfiltered trace and use the TDR cursors to measure the resistance value, R50, approximately 4 ns (displayed) after the resistor discontinuity.

Subtract R50 from R100 producing Delta R.

Correction factor for vertical scale and cursor readings = (Delta R) / 50

To:

#### E.2.2.2.3 Measurement system (with test fixture) calibration

Connect the 50  $\Omega$  cables to the test fixture. In place of "B" in Figure E.1, connect a 137 $\Omega$   $\pm$ 0,1% (preferred) low inductance chip resistor (IMS style TPI-1206 or equivalent) across the pair. Use a differential unfiltered trace and use TDR cursors to measure the resistance value, R137, approximately 4 ns (displayed) after the resistor discontinuity. See figure E.2. The method shown in figure E.2 applies to differential except a 100  $\Omega$  level from the test fixture will be seen and differential signals are displayed.

In a similar manner, in place of "B" in figure E.1, connect a 100 $\Omega$   $\pm$ 0,1% (preferred) low inductance chip resistor (IMS style TPI-1206 or equivalent) across the pair. Use a differential unfiltered trace and use the TDR cursors to measure the resistance value, R100, approximately 4 ns (displayed) after the resistor discontinuity.

For R137 and R100 the equation for determining the corrected (actual) impedance is:



$$Z_{corrected} = 25(1.37 \times X_1 - X_2 - 0.37 \times Z_{measured}) / (X_1 - X_2)$$

Where:

$X_1$  is the measured value using the 100Ω resistor

$X_2$  is the measured value using the 137Ω resistor

**Accept: The above equation is indeterminate. The editor used the following interpretation:**

$$h \quad Z_{corrected} = \frac{25 \times (((1,37 \times X_1) - X_2) - (0,37 \times Z_{mesasured}))}{X_1 - X_2}$$

**SPI-3: 54.22) technical**

A figure is needed in section E.2.2.2.3 to illustrate the differential measurements.

Add the following words to section E.2.2.2.3 along with the Figure.

Figure x shows an example of a differential calibration trace.

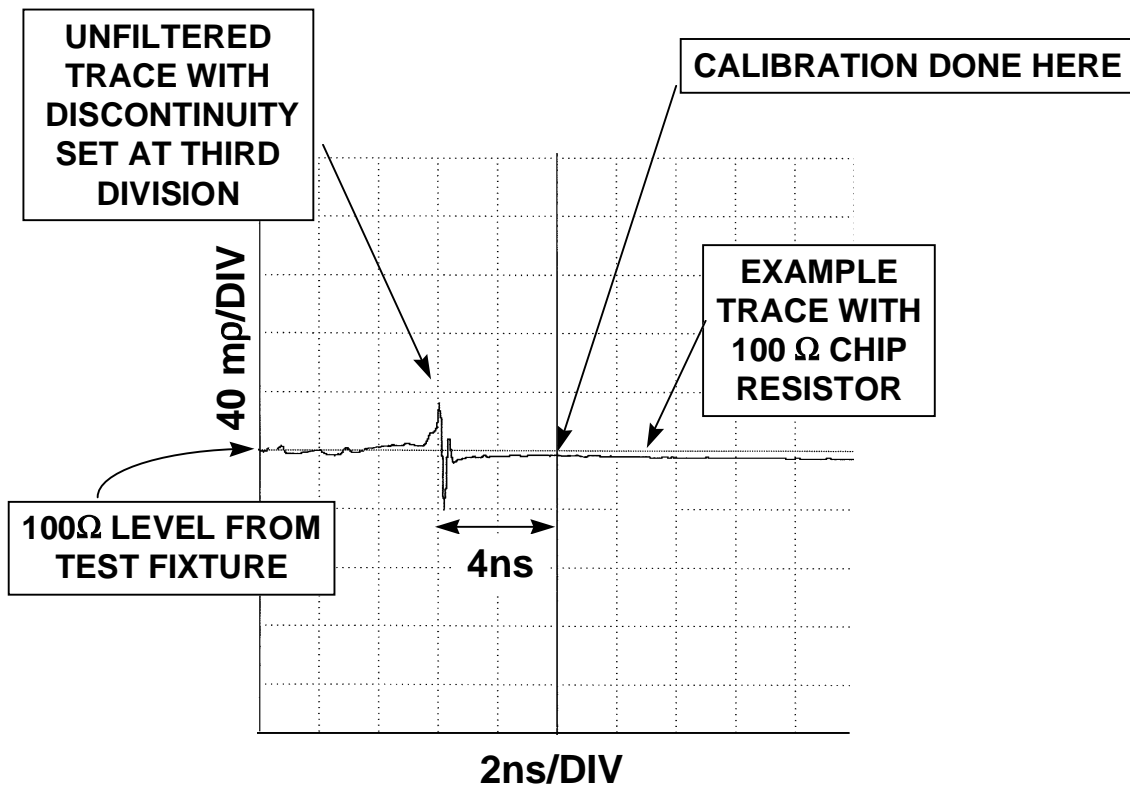

Figure 1 - Example of a differential calibration trace

**Accept**

**SPI-3: 55.23) technical**

In E.2.2.2.4 move the 6<sup>th</sup> item in the list to its own paragraph following the list.

**Accept****SPI-3: 56.24) technical**

In section E.2.2.3

Change:

- f) With the filter turned on to 1ns connect the DUT.
- g) DUT shall be suspended in air. No metallic supports should be used.
- h) Set the TDR cursor to measure minimum, mean, and maximum ohms with cursors set on the trace as it crosses the 5<sup>th</sup> and 6<sup>th</sup> times divisions.
- i) Set the filter to 3 ns.
- j) Set the TDR cursor to measure minimum, mean, and maximum ohms with cursors set on the trace as it crosses the 5<sup>th</sup> and 6<sup>th</sup> times divisions.

To:

- f) With the rise time filter adjusted to achieve 3ns connect the DUT.
- g) Note: unshielded DUT's shall be suspended in air. No metallic supports should be used.
- h) Set the TDR cursor to measure minimum and maximum ohms with cursors set on the trace as it crosses the 5<sup>th</sup> and 6<sup>th</sup> times divisions.
- i) Set the filter to 3 ns.
- j) Set the TDR cursor to measure minimum and maximum ohms with cursors set on the trace as it crosses the 5<sup>th</sup> and 6<sup>th</sup> time divisions.

**Accept****SPI-3: 57.25) technical**

In section E.2.3.1

Change bullet item 2 to read: Remove 5,0 cm of outer jacket from both ends

and add a bullet item 6 to read: Attach a 122  $\Omega$  resistor to the far end of the pair under test.

**Accept****SPI-3: 58.26) technical**

In section E.2.3.2.1

Change:

The first type is constructed using two baluns mounted on aluminum base and electrically isolated from each other by aluminum screen (test fixture 1 figure E.6).

The second type uses high speed PCB with microstrip construction. Two baluns are mounted at one edge of the board with sufficient separation to reduce mutual coupling by a minimum of 20 dB. The interconnect traces of the signal pairs are further separated from each other in a radial form and the signal traces run at  $61\Omega$  to ground for each differential line (test fixture 2 figure E.6).

To:

The first type is constructed using two baluns mounted on a metallic base and electrically isolated from each other by a metallic screen (test fixture 1 figure E.6).

The second type uses high speed PCB with microstrip construction. Two baluns are mounted at one edge of the board with sufficient separation to reduce mutual coupling by a minimum of 20 dB. The interconnect traces of the signal pairs are further separated from each other in a radial form and the signal traces run at  $61\Omega$  nominal to ground for each differential line (test fixture 2 figure E.6).

**Accept**

### **SPI-3: 59.27) technical and editorial**

Change the existing sections E.2.3.2.3 and E.2.3.2.4 to the following:

#### E.2.3.2.3 Test Fixtures

For the metallic base test fixture (test fixture 1), the transmission line is provided by the baluns as the signal paths and the metallic base as the current return path. The baluns provide a 50 to  $61\Omega$  impedance matching between the test instrument system and the DUT, as well as provide differential signals. The metallic screen provides electric field isolation between the two baluns. The DUT connects to the fixture via a mechanical clamp system. The DUT should self terminate given its length.

#### E.2.3.2.4 Fixture board design requirements (test fixture 2 figure E.6):

For the PCB test fixture, the test fixture consists of a printed circuit board incorporating controlled impedance trace construction of  $61\Omega$  (refer to test fixture 2 figure E.6). The transmission line is provided by the connected baluns and PCB traces for the signal paths and the ground plane of the board for the return current path. A coaxial cable (same transmission line impedance as the test instrument) connects one end of the cable to the instrument test port through the baluns and the PCB fixture trace combination. The baluns provide a 50 to  $61\Omega$  impedance matching between the test instrument system and the DUT, as well as provide differential signals. The separation of the baluns and the signal lines provide electric field isolation between the two baluns and the signal lines. The DUT connects to the fixture via a mechanical clamp system. The DUT should self terminate given its length.

NOTE 54 - The baluns required for this test are high frequency (650 MHz or greater) precision types.

A stand is recommended for mounting fixture board and to support the DUT. It is recommended that the stand keep the fixture board at least 7 cm from the top of the lab bench to minimize coupling.

Traces are constructed on the PCB to conform with the differential transmission scheme. The fixture shall be through hole or surface mount PCB. The signal traces are connected to the balun's differential pins using microstrip construction with controlled transmission line impedance of  $61\Omega$ . The length of the connections shall permit the board to operate at the desired frequencies and accommodate the required number of signal lines, including sufficient separation to reduce mutual coupling by a minimum of 20 dB. It is recommended that the bandwidth of the board be at least 650 MHz. Board impedance shall be tightly controlled to within 5% of the impedance of the environment.

The fixture board shall include calibration traces for measuring the effects of the test fixturing on the measured data. This board construction is useful for other frequency domain measurements but is not designed to accommodate time domain.

**Accept**

**SPI-3: 60.28) technical**

In section E.2.3.4 add the statement:

Note: unshielded DUT's shall be suspended in air. No metallic supports should be used.

Immediately before the existing wording:

Connect the near end of the sample to the output balun on the test fixture, keeping the leads as short as....

**Accept**

**SPI-3: 61.29) technical**

Delete the following from section E.3.1.1

For round cables shield floating:

- 1) Cut sample length to 3 m.
- 2) Remove 5,0 cm of outer jacket from one end.
- 3) Cut braid wire back to jacket.
- 4) Trim filler and tape materials to the base of braid wire.
- 5) Strip 0,5 cm insulation from all conductors.

**Accept**

**SPI-3: 62.30) technical**

In section E.3.1.2

change: See E.2.2.2 for appropriate test fixtures.

To: Figure x shows the configuration to use for this measurement procedure.

Add the following figure x describing the test fixture to section E.3.1.2 with the title "Test fixture for single ended capacitance measurement".

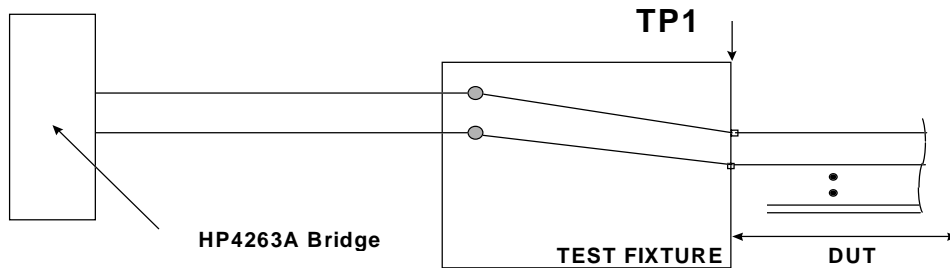

**TEST FIXTURE / MEASUREMENT PROCESS IS CALIBRATED  
TO REPORT AT TP1**

**SPI-3: 63.31) technical**

In section E.3.1.3

Change the second bullet to:

2) Connect a wire (short) to the sockets of the test fixture and perform a “short” calibration as specified by HP.

**Accept**

**SPI-3: 64.32) technical**

Remove the following section:

E.3.1.4.1 Flat cables - G-S

With the bridge set at the desired frequency, connect the pair to the test fixture and record the capacitance.

**Accept**

**SPI-3: 65.33) technical**

Change:

E.3.1.4.3 Round cables - shielded

With the bridge set at the desired frequency, connect one half of the twisted pair to one side of the test fixture and the other half of the twisted pair to the shield and to the other side of the test fixture. Record the capacitance.

To:

E.3.1.4.3 Round cables - shielded

With the bridge set at the desired frequency, connect one conductor of the twisted pair to one side of the test fixture. Connect the common conductors and shield to the other side of the test fixture (ground). Record the capacitance.

**Accept**

**SPI-3: 66.34) technical**

Remove the following section:

E.3.1.4.4 Round Cables - floating shield

With the bridge set at the desired frequency, connect the twisted pair to the test fixture. Record the capacitance.

**Accept**

**SPI-3: 67.35) technical**

Remove the following material:

For round cables shield connected:

- 1) Cut sample to a length that eliminates resonance.
- 2) Remove 5,0 cm of outer jacket from both end.
- 3) Comb out braid wire strands to form a pig tail.
- 4) Trim filler and tape materials to the base of braid wire.
- 5) Strip 0,5 cm insulation from all conductors.
- 6) Connect one (1) conductor of each pair to the shield.

**Accept**

**SPI-3: 68.36) technical**

In section E.3.2.2

Change:

See E.2.2.2 for appropriate test fixtures.

To:

Refer to Figure x for the proper test configuration.

[Add a new Figure x shown below titled "Test fixture for differential capacitance measurements"].

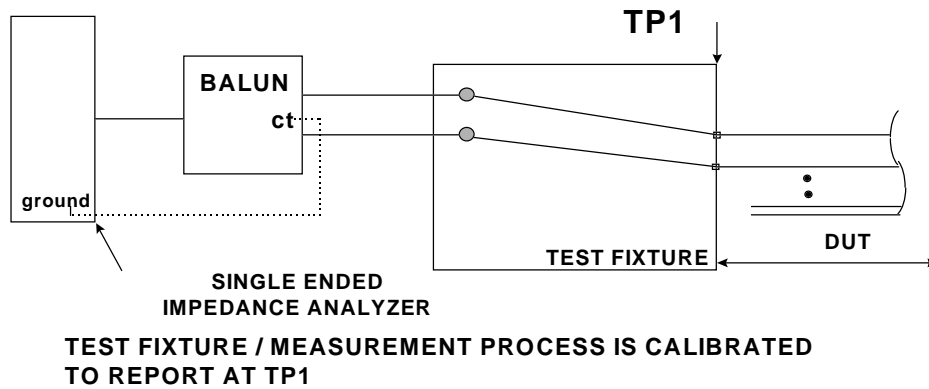

**Accept**

**SPI-3: 69.37) editorial**

In E.3.2.3.1 change bullet 6 to:

6) Record the linear measurement

**Accept**

**SPI-3: 70.38) editorial**

In E.3.2.3.2 change:

For other manufacture's equipment, follow the calibration procedures specified by the manufacturer for reliable results.

To:

For other instruments follow the calibration procedures specified by the manufacturer for reliable results.

**Accept**

**SPI-3: 71.39) technical**

In Section E.3.3

Change:

Selection of this test method is on underway.

To:

This measurement procedure is not specified in this document.

**Accept**

**SPI-3: 72.40) technical**

In E.4.1 remove bullet 6):

6) Each pair under test shall be terminated with a 100  $\Omega$  resistor at the far end of the cable.

**Accept**

**SPI-3: 73.41) technical**

In section E.4.2

Change:

See E.2.2.2 for appropriate test fixtures.

To: See Figure E-14 for appropriate test fixture.

**Accept**

**SPI-3: 74.42) technical**

In section E.4.3 Change:

The analyzer shall be set to perform a S12 measurement with the power set at a minimum of 6 dbm, the number of points set to a minimum of 401, the band width at a maximum of 200 Hz, averaging at a minimum of 2 averages, and the start/stop frequencies per the table. Perform a transmission calibration using a sample of the cable to be tested keeping the sample as short as possible.

To:

The analyzer shall be set to perform an S12 measurement with the power set at a minimum of 6 dBm, the number of points set to a minimum of 401, the resolution bandwidth at a maximum of 200 Hz, averaging at a minimum of 2 averages, and the start/stop frequencies per Table E.1. Perform a transmission calibration using a sample of the cable to be tested keeping the sample as short as possible.

**Accept**

**SPI-3: 75.43) editorial**

In E.4.4 change:

With the analyzer set up in the delay mode, connect one end of the sample to the balun on the output port and the opposite end to the balun on the input port with the markers turned on record the minimum and maximum delay across the band width as listed in table E.1.

To:

With the analyzer set up in the delay mode, connect one end of the sample to the balun on the output port and the opposite end to the balun on the input port. With the markers turned on record the minimum and maximum delay across the bandwidth as listed in table E.1.

**Accept**

**SPI-3: 76.44) technical**

In section E.5.1 change:



This test requires type D sample (see table E.1) prepared in the following way:

To:

This test requires type H sample (see table E.1) prepared in the following way:

**Accept**

**SPI-3: 77.45) technical**

In section E.5.1 change:

For round cables shield connected:

To:

For round cables shield floating:

**Accept**

**SPI-3: 78.46) technical**

In section E.5.2 change:

See E.2.2.2 for appropriate test fixtures.

To: See Figure x for appropriate test fixture.

Add new figure x given below showing the test fixture with the title "Propagation time measurement setup".

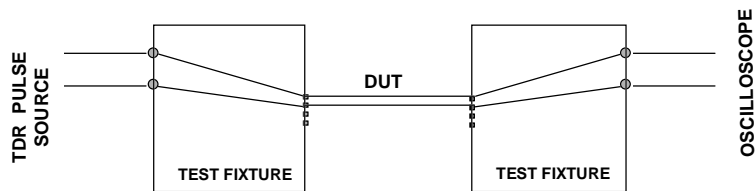

**TEST FIXTURE TO MEASURE PROPAGATION TIME**

**Accept**

**SPI-3: 79.47) technical**

In Table E-1 under Diff propagation time (frequency) change:

An S12 measurement

To: An S12 measurement swept from 10 MHz to 650 MHz (normative measurement with no pass/fail levels)

**Accept**

**SPI-3: 80.48) technical**

In Table E-1 under Diff propagation time (time) change:

Modified to 3 m

To: Sample 6m

**Accept**

**SPI-3: 81.49) editorial**

In Table E-1 under Diff attenuation change:

(H) Sample leave all other lines open -long enough to produce at least 1dB at the low frequency shelf (note 3) (typically > 30 m)

To:

(I) Sample leave all other lines open -long enough to produce at least 1dB at the low frequency shelf (note 3) (typically > 30 m)

**Accept**

**SPI-3: 82.50) editorial**

Under E.5.3 change: For other manufacture's equipment, use the same procedure adapted for that instrument.

To: For other instruments, use the same procedure adapted for that instrument.

**Accept**

**SPI-3: 83.51) technical**

Under E.6.1 change: Maximum propagation time minus the minimum propagation time renders the overall propagation time skew of the pair under test.

To: Using the time domain (through) measurement, maximum propagation time minus the minimum propagation time renders the overall propagation time skew of the pair under test.

**Accept**

**SPI-3: 84.52) technical**

In section E.7.1 change:

Attenuation (dB) =  $20 \log_{10} (\text{input signal} / \text{output signal})$ . and

Gain (dB) =  $20 \log_{10} (\text{output signal} / \text{input signal})$

To:

Attenuation (dB) =  $20 \log_{10}$  (input voltage / output voltage). and

Gain (dB) =  $20 \log_{10}$  (output voltage / input voltage)

**Accept**

**SPI-3: 85.53) technical**

In section E.7.1 change:

At higher frequencies, the conductor loss increases due to skin effect. Skin effect is where the current become increasingly confined in the outer “skin” of the conductor as the frequency increases. This effectively reduces the conductor area available for current flow. The attenuation for a given balanced transmission line will be affected by the conductor metal composition and size, and the composition, uniformity, and thickness of the dielectric that surrounds the conductors.

To:

At higher frequencies, the conductor loss increases due to skin effect. Skin effect is where the current becomes increasingly confined to the outer “skin” of the conductor as the frequency increases. This effectively reduces the conductor area available for current flow. The attenuation for a given transmission line will be affected by the conductor metal composition and size, and the composition, uniformity, and thickness of the dielectric that surrounds the conductors.

**Accept**

**SPI-3: 86.54) technical**

Insert the following new section in front of the present section E.7.1.1:

E.7.1.1 Sample preparation

- 1) Cut sample to a length that produces at least 1 dB attenuation at the low frequency shelf (typically at least 30 meters).
- 2) Remove 5,0 cm of outer jacket from both ends.
- 3) Cut braid wire back to jacket.
- 4) Trim filler and tape materials to the base of braid wire.
- 5) Strip 0,5 cm insulation from all conductors.

**Accept**

**SPI-3: 87.55) technical**

In section E.7.1.1 change

A test fixture having 75  $\Omega$  single ended paths for each signal line is used for the measurement as shown in

To:

A test fixture having 61  $\Omega$  single ended paths for each signal line is used for the measurement as shown in

**Accept**

**SPI-3: 88.56) technical**

In section E.7.1.1 replace Figures E.12, E.13, and E.14 with the following respective figures: (same figure titles)

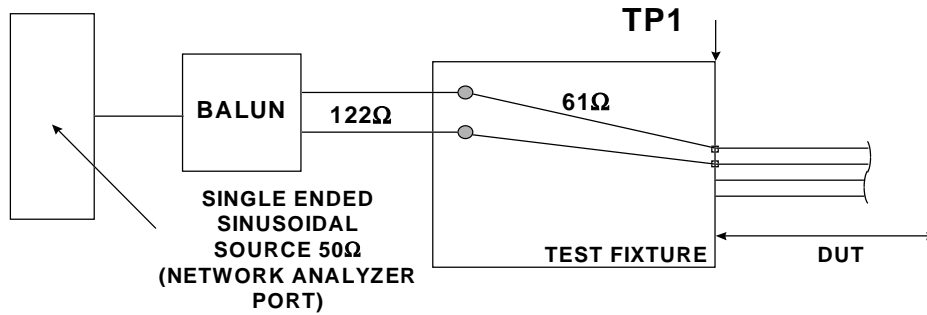

**TEST FIXTURE / MEASUREMENT PROCESS IS CALIBRATED TO REPORT AT TP1**

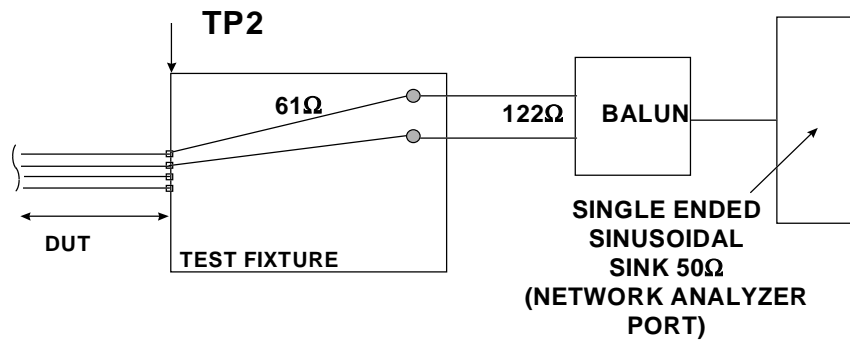

**TEST FIXTURE / MEASUREMENT PROCESS IS CALIBRATED TO REPORT VALUES AT TP2**

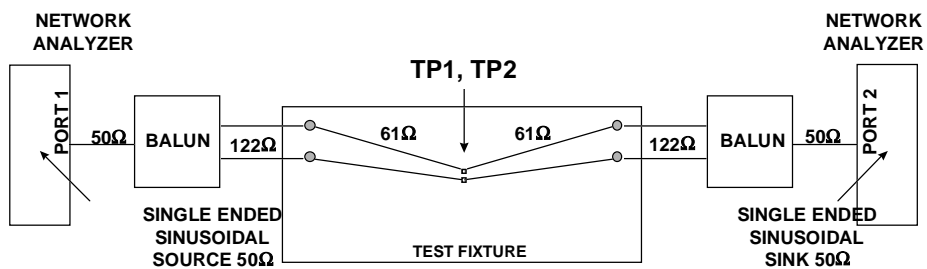

**TEST FIXTURE / MEASUREMENT PROCESS IS CALIBRATED TO REPORT VALUES AT IUT CONNECTION POINT (TP1, TP2)**

Accept

**SPI-3: 89.57) editorial**

Change the last sentence in E.7.1.3: The separable DUT is connected between the source and sink test fixtures.

To: The DUT is connected between the source and sink test fixtures.

**Accept**

**SPI-3: 90.58) editorial**

In the last sentence in E.7.1.4 change “from” to “for”.

**Accept**

**SPI-3: 91.59) editorial**

In E.7.1.5

Change:

The instrument automatically accounts for the attenuation found in the calibration scan.

To: The instrument automatically compensates for the attenuation found in the calibration scan.

**Accept**

**SPI-3: 92.60)**

In E.7.1.5 change: When the attenuation of the cable exceeds ~ 50 dB or

To: When the attenuation of the cable exceeds approximately 50 dB or

**Accept**

**SPI-3: 93.61) technical**

In E.8 change: Single pulse tests eliminate the effects of resonance, are very deterministic

To: Single pulse tests that eliminate the effects of resonance, are very deterministic

**Accept**

**SPI-3: 94.62) technical**

In section E.8.3 change Figure E.17 to:

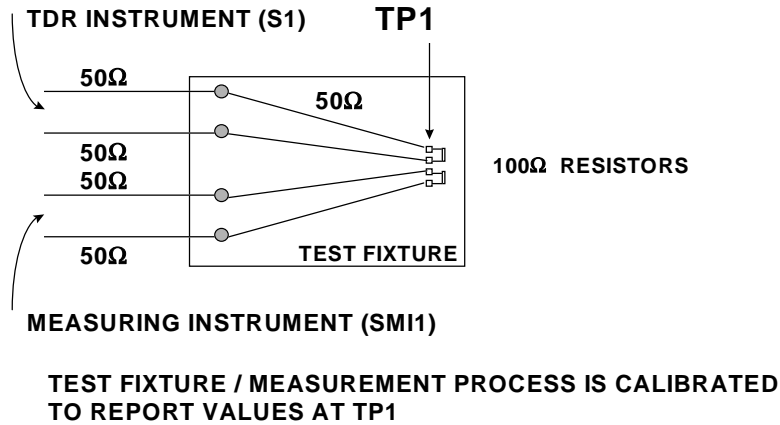

Accept

**SPI-3: 95.63) technical**

In E.8.3 change:

Use the 100% differential amplitude.

To: Use the 100% differential amplitude as defined in Figure E.3

Accept

**SPI-3: 96.64) technical**

In E.8.4 change: Figure E.18 to:

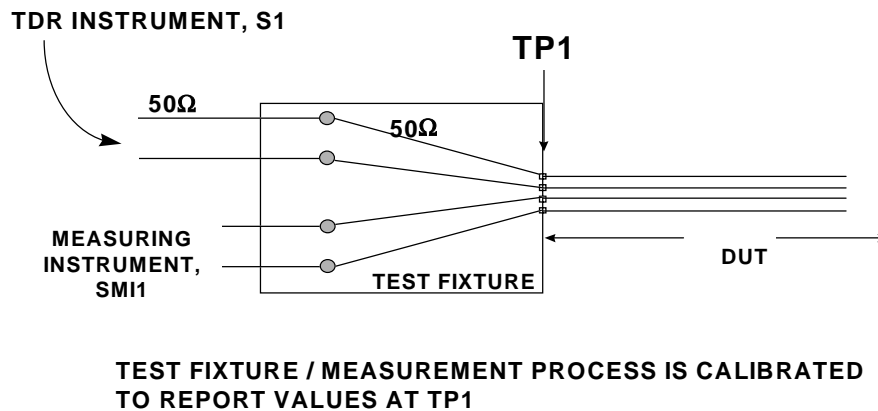

Accept

**SPI-3 Revision 10 Letter Ballot Comments by Rob Elliott, Compaq Computer Corporation**

The first three comments need to be addressed to change the NO vote to a YES vote.

**SPI-3: 97.1) CPQ 101**

Page 085 Section 9.1 Table 32

The receive assertion period and receive negation period at fast-80 DT are too large. The transmitted values are 11.5 ns. The receive values are 10 ns. Over a variety of backplanes, an achievable number is 8.5 ns. The periods with P\_CRCA transition should be similarly reduced by 1.5 ns.

The slower rates are acceptable as is. The new timing values would be:

	fast-10DT	fast-20DT	fast-40DT	fast-80DT
Receive assertion period	80	40	20	<del>40</del> <b>8,5</b>
Receive negation period	80	40	20	<del>40</del> <b>8,5</b>
Receive assertion period with P_CRCA transitioning	85,5	48	32,5	<del>22,5</del> <b>21</b>
Receive negation period with P_CRCA transitioning	85,5	48	32,5	<del>22,5</del> <b>21</b>

**Accept: GOP - unless objection is heard**

**SPI-3: 98.2) CPQ 102**

Page 100 Section 10.2.2

Compaq has some old devices that respond to single-bit selections. These devices might think they are being selected during the QAS force BUS FREE algorithm described. These changes should help:

- 1) Perform a QAS arbitration;
- 2) on winning QAS arbitration, assert SEL while asserting only the initiator's own ID on the data bus;
- 2.5) wait a bus settle delay;
- 2.6) if BSY is detected true within a selection abort time, send an INQUIRY command to the target. The target should force a BUS FREE after completing the command;
- 2.7) if BSY is detected false throughout the selection abort time, release SEL and the data bus;
- 3) ~~after detecting BSY false, release SEL and the data bus; and~~
- 4) after a bus settle delay from SEL and BSY false, the bus is in BUS FREE phase. The initiator may then arbitrate using a normal arbitration and perform a selection if it wins.

**Accept: The following wording added to 10.2.2**

**A QAS initiator may interrupt a sequence of QAS cycles to force a normal arbitration with the following procedure:**

- 1) **Perform a QAS arbitration;**
- 2) **on winning QAS arbitration, continue driving the initiator's ID on the data bus instead of asserting SEL to enter selection phase;**
- 3) **wait until the target transitions to BUS FREE (this occurs after two QAS arbitration delays);**
- 4) **after detecting BSY false, release the data bus; and**
- 5) **after a bus settle delay from when the target drove BSY false, the bus is in BUS FREE phase. The initiator may then arbitrate using normal arbitration and perform a selection if it wins.**

**SPI-3: 99.3) CPQ 103**

Page 258 Section L.2.2 and L.5

Remove the paragraph “During these tests, the application client should prevent other processes from using the SCSI device. The application client should use the RESERVE command to prevent other initiators from altering the data buffer in the target”. This topic is covered by section L.5 Buffer Protection.

Change L.5 as follows:

The READ BUFFER and WRITE BUFFER commands access physical buffers in the target. Many implementations do not protect the buffer contents if there is an intervening command from any other process. Therefore, the application client should ensure that no other SCSI processes are active while performing tests.

~~The RESERVE command may be used to block commands from other initiators. However, using the RESERVE command is not sufficient to prevent commands from the same initiator (possibly issued by other processes) from corrupting the buffer contents. Also, targets with multiple logical units may corrupt the buffer if commands are processed on other logical units.~~

The READ BUFFER and WRITE BUFFER commands include an echo buffer option that ~~may be especially valuable when performing these tests~~ provides buffer protection in multi-initiator environments. Other mechanisms that may help prevent buffer corruption in multiple initiator environments are RESERVE/RELEASE and linked commands.

The remaining comments are not required to be addressed to convert the vote to a YES.

**Accept**

**SPI-3: 100.4) CPQ 104**

Page xxii Section Introduction

Second line: remove “typically”

**Accept**

**SPI-3: 101.5) CPQ 105**

Page 001 Section 1

Third line: end with a colon

First b) and c): remove commas after each “SCSI-2” (3 times)

**Accept**

**SPI-3: 102.6) CPQ 106**

Page 001 Section 1

Formatting is different between the first a) b) list and the second a) b) c) d) list. The first style seems prevalent in the rest of the document, although the second is more readable.

**Accept**

**SPI-3: 103.7) CPQ 107**

Page 002 Section 1

Change “Fiber” to “Fibre” (2 times)



**Accept**

**SPI-3: 104.8) CPQ 108**

Page 003 Section 2.2

Add SCC to the approved references list (referred to on page 165)

**Accept**

**SPI-3: 105.9) CPQ 109**

Page 020 Section 4.8.2.1 Second paragraph

If the number of the bytes in the data field is 3, there should not be a pad. This doesn't match "is not a multiple of 4." Something like this text would clarify the description:

The number of bytes in the data field shall be even. An unused byte in the data field may be indicated by the IGNORE WIDE RESIDUE message.

**SPI-3: 106.10) CPQ 110**

Page 042, 045 Section 5.4.1 and 5.4.2 Tables 5 and 8

Change "DB((15)" to "DB(15)"

**Accept**

**SPI-3: 107.11) CPQ 111**

Page 050 Section 6.3.10

Change header "Cross talk" to "Crosstalk"

Change "3.0" to "3,0"

**Accept**

**SPI-3: 108.12) CPQ 112**

Page 075 Section 7.4.2 Note 15

Change "fast-40" to "fast-40 or fast-80" (2 times) or "rates faster than fast-20"

**Accept**

**SPI-3: 109.13) CPQ 113**

Page 079 Section 8.2

The P\_CRCA signal definitions are still confusing. Also, the signal is valid in SELECTION phase which is not mentioned. I suggest a hierarchical description.

**P\_CRCA (PARITY/CRC AVAILABLE).** A signal indicating either parity or CRC available based on bus phase and negotiated settings. This uses the same line as the DB(P0) signal in previous versions of this standard.

SELECTION phase,

ST DATA phase,

COMMAND phase,

MESSAGE phase,

**STATUS phase. Referred to as DB(P\_CRCA).** A signal sourced by the SCSI device driving the data bus during these phases. This signal is associated with the DB(7-0) signals and is used to detect the presence of an odd number of bit errors within the byte. The parity bit is driven such that the number of logical ones in the byte plus the parity bit is odd.

**DT DATA phase (data group transfer enabled). Referred to as P\_CRCA.** A signal sourced by a target during DT DATA phases to control whether a data group field is a pad field, pCRC field, or data field (see 10.5.2.2.2). When asserted the data group field shall be pad or pCRC fields that shall not be transferred to the ULP. When negated the data group field shall be a data field that shall be transferred to the ULP.

**DT DATA phase (information unit transfers enabled). Referred to as P\_CRCA.** During DT DATA phases, while information unit transfers are enabled, a signal sourced by a target that shall be continuously negated by the target and shall be ignored by the initiator.

**Accept: Section re-written although not in the same way indicated**

### **SPI-3: 110.14) CPQ 100**

Page 079 Section 8.2

The P1 signal definitions are still confusing. Also, the signal is valid in SELECTION phase which is not mentioned. I suggest a hierarchical description.

**P1 (PARITY 1).** A signal normally sourced by the SCSI device driving the data bus. This uses the same line as the DB(P1) signal in previous versions of this standard.

SELECTION phase,

COMMAND phase,

MESSAGE phase,

STATUS, phase,

**ST DATA phase (8-bit transfer width). Referred to as DB(P1).** A signal that shall not be driven by any SCSI device.

**DT DATA phase. Referred to as P1.** A signal sourced by the SCSI device driving the data bus during ST DATA phases. This signal is associated with the DB(15-8) signals and is used to detect the presence of an odd number of bit errors within the byte. The parity bit is driven such that the number of logical ones in the byte plus the parity bit is odd.

**DT DATA phase. Referred to as P1.** A signal that shall be continuously negated by the SCSI device driving the DB(15-0) signals and shall be ignored by the SCSI device receiving the DB(15-0) signals during DT DATA phases.

**Accept: Section re-written although not in the same way indicated**

### **SPI-3: 111.15) CPQ 114**

Page 078-079 Section 8.2

The order of the signals is not obvious. Consider one of these options:

- a) alphabetical order

- b) create a hierarchy
  - OR-tied signals (BSY SEL RST)
  - Target-driven (CD IO MSG REQ)
  - Initiator-driven (ACK ATN)
  - Initiator or target-driven (DB, P\_CRCA, P1)

**Accept: Option b used**

**SPI-3: 112.16) CPQ 115**

Page 081 Section 8.3.2. Figure 43

Change “Signaling sense” to “LVD signaling sense”

**Accept**

**SPI-3: 113.17) CPQ 116**

Page 082 Section 8.5 Table 29

Init note: change “this signal” to “the signal”

Targ note: change “If the signal is driven, it shall” to “If driven, the signal shall” to match the Init note wording

PT note: Change “Target that initiated” to “The signal shall be driven by the target that initiated”

**Accept**

**SPI-3: 114.18) CPQ 117**

Page 083, 084, 085 Section 9.1, Tables 30, 31, 32

Add a column named “Type” that indicates whether the number is a minimum or maximum value. The text usually clarifies the type, but it would be helpful if it were mentioned in the table.

All types would be minimums except for these maximums:

Table 30. bus clear delay, bus set delay, cable skew, data release delay, power on to selection, QAS assertion delay, QAS release delay, reset to selection, selection abort time

Table 31. cable skew, signal timing skew, transmit req(ack) period tolerance.

Table 32. cable skew, signal timing skew, transmit req(ack) period tolerance.

(Note: another comment discusses whether the tolerances should be minimums or maximums)

**Accept**

**SPI-3: 115.19) CPQ 118**

Page 089 Section 9.2.34

Currently, “Signal Timing Skew” is a superset of another entry in the table, “Cable Skew.” Page 96 and 97 (figures 49 and 50) contain further definitions for these terms:

Signal timing skew includes cable skew and signal distortion skew

Signal distortion skew includes ISI (intersymbol interference) and signal crossing time through the receiver detection range

I suggest creating a new timing value called "Signal distortion skew" and simplifying the Signal Timing Skew definition to refer to the two components.

These are the values for Signal distortion skew that would go in the tables (calculated as Signal Timing Skew minus Cable Skew):

table 31: 4 ns/4ns/4ns/2ns/2ns

table 32: 22,8 ns/10,4ns/4,2ns/0,85ns

The type would be "max" for the Type column recommended by a previous comment.

Remove the notes from the figures 49 and 50 since they are redundant.

New and modified text:

#### 9.2.xx Signal Distortion Skew

The maximum skew allowed from intersymbol interference (ISI), transmission line reflections, and signal crossing time through the receiver detection range.

Intersymbol interference causes skew when transferring random data in combination with interruptions of the REQ (ACK) signal transitions (e.g., pauses caused by offsets).

The receiver detection range is the part of the signal between the "may detect" level and the "shall detect" level on either edge. (see 9.3)

#### 9.2.34 Signal Timing Skew

The maximum signal timing skew consists of cable skew plus signal distortion skew.

~~The maximum signal timing skew occurs when transferring random data and in combination with interruptions of the REQ (ACK) signal transitions (e.g., pauses caused by offsets). The signal timing skew includes cable skew (measured with 0101... patterns) and signal distortion skew caused by random data patterns and transmission line reflections as shown in figure 44, figure 45, figure 46, and figure 47.~~

~~The receiver detection range is the part of the signal between the "may detect" level and the "shall detect" level on either edge. (see 9.3)~~

**Needs discussion GOP**

### **SPI-3: 116.20) CPQ 119**

Page 088, 089 Section 9.2.25, 9.2.40

The definitions for transmit and receive REQ(ACK) period tolerance do not agree on minimum/maximum wording:

Transmit: The maximum tolerance that a SCSI device may subtract from the REQ (ACK) period.

Receive: The minimum tolerance that a SCSI device shall allow to be subtracted from the REQ (ACK) period.

The Transmit wording seems correct. If the REQ (ACK) period is 25 ns, a fast-80 transmitter may subtract 0.6 ns from it, transmitting with a period of 24.4 ns. It may not subtract 1.0 ns.

The Receive wording seems wrong. The fast-80 receiver "shall allow" a minimum of 0.7 ns to be subtracted from the REQ (ACK) period of 25 ns. Since 1.0 ns is greater than 0.7 ns, does it mean the receiver must tolerate a 24 ns input period?

I suggest:

Transmit: The maximum tolerance that a SCSI device may subtract from the REQ (ACK) period.

Receive: The maximum tolerance that a SCSI device shall allow to be subtracted from the REQ (ACK) period.

**Reject - The current wording is correct if not clear.**

**SPI-3: 117.21) CPQ 120**

Page 086-090 Section 9.2.

I suggest adding short explanations of some of these timing values. Since these questions keep coming up in committee meetings, readers with just the specification must be even more confused.

*Bus settle delay:* This provides time for a signal transition to propagate from the driver to the terminator and back to the driver.

*ATN transmit setup time:* Extra time is specified to provide the increased ATN receive setup time, subject to intersymbol interference, cable skew, and other distortions.

*ATN receive setup time:* Extra time is specified to ease receiver timing requirements (previous versions of this standard provided two system deskew delays of setup time).

*pCRC Transmit setup time:* Extra time is specified to provide the increased Receive setup time, subject to intersymbol interference, cable skew, and other distortions.

*pCRC Receive setup time:* Extra time is specified to ease receiver timing requirements and ensure that this signal, which is outside CRC protection, is received correctly.

*Transmit REQ assertion period with P\_CRCA transitioning:* Extra time is specified to provide the increased Receive REQ assertion period, subject to loss on the interconnect.

*Receive REQ assertion period with P\_CRCA transitioning:* Extra time is specified to ensure that the assertion period is longer than the receive hold time plus the receive setup time.

*Transmit REQ negation period with P\_CRCA transitioning:* Extra time is specified to provide the increased Receive REQ negation period, subject to loss on the interconnect.

*Receive REQ negation period with P\_CRCA transitioning:* Extra time is specified to ensure that the negation period is longer than the receive hold time plus the receive setup time.

**Accept**

**SPI-3: 118.22) CPQ 121**

Page 088 Section 9.2.28

The text does not specify whether this is a minimum or maximum time.

Change “is measured from” to “is the minimum time between”.

Also, change “qualified the assertion edge” to “qualified on the assertion edge.”

**Accept**

**SPI-3: 119.23) CPQ 122**

Page 090 Section 9.3

Change “differential” to “LVD”.

**Accept**

**SPI-3: 120.24) CPQ 123**

Page 093 Section 9.3.3 Figure 46 and 47

Figure 46: add \* by the leftmost “may be detected” and “shall be detected” arrows. This forces the first zero crossing to be chosen for the “may” level (shorter SETUP) and the last –100 mV crossing to be chosen for the “shall” level (shorter HOLD).

Figure 46: add a new \*\* by the rightmost “may be detected” and “shall be detected” arrows. The comment for these would be “Use the crossing that yields the shorter ASSERTION PERIOD and NEGATION PERIOD”.

Figure 47: add \* by the each of the “may be detected” and “shall be detected” arrows. Change the note to “Use the crossing that yields the shorter SETUP time, HOLD time, ASSERTION PERIOD, and NEGATION period”

**Needs discussion GOP**

**SPI-3: 121.25) CPQ 124**

Page 095-097 Section 9.4

The “board skew” and “protocol chip” values are introduced here for the first time. They’re not mentioned in the main timing tables earlier. Some definition of them might be appropriate.

Add this text:

Table 31 and Table 32 specify setup and hold times at the device connector. Figure 49 and Figure 50 illustrate a possible timing budget behind the device connector, with time apportioned to board skew and to the protocol chip.

**Needs discussion GOP**

**SPI-3: 122.26) CPQ 125**

Page 096-097 Section 9.4

The figures show how the time adds up for setup and hold times.

There is no similar explanation of how the clock assertion and negation signals are allowed to degrade. At fast-80DT rates, the transmit period is 11.5 ns and the receive period is 10 ns. The overall REQ/ACK period is 25 ns, subject to a REQ/ACK period tolerance. Figures showing how these numbers relate would be helpful. There seems to be no guidance in the standard about how fast the transmit protocol chip must switch the signal, how much loss the board may introduce.

Something like this.

fast-80DT	REQ/ACK Period
Nominal	25
period tolerance	-0.6
Actual budget	24.4

	Assertion period	Negation period
Nominal	12.5	12.5
period tolerance split evenly	-0.3	-0.3
transition time	-0.5	-0.5
Transmit protocol chip	11.7	11.7
board loss	-0.2	-0.2
Transmit connector (Transmit A/N Period)	11.5	11.5
cable loss	-1.5	-1.5
Receive connector (Receive A/N Period)	10	10
board loss	-0.2	-0.2
Receive Protocol chip	9.8	9.8

**Needs discussion GOP (This looks like a SPI-4 activity)**

**SPI-3: 123.27) CPQ 126**

Page 098 Section 10

Should BUS FREE, ARBITRATION, SELECTION, and RESELECTION collectively be called the control phases? If done, then change the header for Table 30 (Section 9.1) to refer to “control phase” instead of “control”.

**Reject: It might be able to use that term by way add layers of terminology when this area has been this way forever.**

**SPI-3: 124.28) CPQ 127**

Page 099 Section 10.2

Change semicolon to colon after “SCSI bus”

**Accept**

**SPI-3: 125.29) CPQ 128**

Page 099 Section 10.2.1

Add blank line between b) and c).

Change “, however” to “. However,” in item c)

**Accept**

**SPI-3: 126.30) CPQ 129**

Page 099 Section 10.2.1

Remove “in the Disconnect-Reconnect mode page (see 18.1.1). Initiators don't have that page, yet still might be fair.

**Accept: Changed the wording as follows:**

**If the SCSI device is a target and arbitration fairness is enabled in the Disconnect-Reconnect mode page (see 18.1.2), the target shall not arbitrate until its fairness register is cleared (see Annex B)**

**SPI-3: 127.31) CPQ 130**

Page 099 Section 10.2

Integrate basic fairness algorithm requirements into the arbitration section.

Add some text about fairness as the last paragraph:

SCSI devices with arbitration fairness enabled shall maintain a fairness register which records the SCSI IDs of devices that need a chance to arbitrate (see Annex B). Fairness in normal arbitration is enabled in targets by the Disconnect-Reconnect mode page (see 18.1.1). Fairness is always enabled in QAS.

**Accept**

**SPI-3: 128.32) CPQ 131**

Page 099 Section 10.2.1 Note 23

Add “, and may not be ensured fair arbitration by the arbitration fairness algorithm.” to the end of the note.

**Accept**

**SPI-3: 129.33) CPQ 132**

Page 100 Section 10.2.1

First line. Change “true and within” to “true, within”

Second line. Change “SEL” to “SEL signal”.

**Accept**

**SPI-3: 130.34) CPQ 133**

Page 100 Section 10.2.1

Integrate basic fairness algorithm requirements into the normal arbitration description.

Add an item and note between d) and e):

d.5) After the bus free delay in step (b), SCSI devices with arbitration fairness enabled which are not arbitrating shall wait a bus set delay and start sampling the DATA BUS to determine which SCSI devices attempted arbitration, which SCSI device won, and which SCSI devices lost. This sampling shall continue for an arbitration delay after the bus free delay in step (b). Each SCSI device shall update its fairness register with all lower-priority device IDs that lost arbitration.



NOTE xx: For ease of implementation, this sampling may begin when BSY is true following BUS FREE and end when SEL is true.

**Accept**

**SPI-3: 131.35) CPQ 134**

Page 100 Section 10.2.2

Change “An initiator that supports QAS shall negotiate...using the PPR, in order to enable QAS” to “An initiator that supports QAS may negotiate...using the PPR message.” The “in order to” is too far away from the start of the sentence. It seems to be requiring QAS be used with QAS targets.

**Accept: Wording changed as follows:**

**In order to enable QAS, an initiator that supports QAS shall negotiate, using the PPR message, the use of the QAS phase with each target that has indicated support of QAS. Any time the data transfer agreement is in an indeterminate state the initiator shall renegotiate to enable QAS.**

**SPI-3: 132.36) CPQ 135**

Page 100 Section 10.2.2

Remove “and normal” from “SCSI devices that support QAS shall implement the fairness algorithm during all QAS and normal arbitrations.” QAS capability has no bearing on non-QAS arbitration behavior.

**Accept**

**SPI-3: 133.37) CPQ 136**

Page 100 Section 10.2.2.1

Item b) Change “message and if the initiator did not create an attention condition then” to “message, if there is no attention condition,”

**Accept**

**SPI-3: 134.38) CPQ 137**

Page 100 Section 10.2.2.1

Item c) Change “true and if there is no attention condition the” to “true, if there is no attention condition, “

**Accept**

**SPI-3: 135.39) CPQ 138**

Page 100 Section 10.2.2.1

Item f) Change “of the SCSI signals” to “the SCSI signals”

**Accept**

**SPI-3: 136.40) CPQ 139**

Page 101 Section 10.2.2.1

Integrate basic fairness algorithm requirements into the QAS description.

Item a) Remove “if allowed under the fairness algorithm.”

Item c) Add to end: “If arbitration fairness is enabled, the SCSI device shall not arbitrate until its fairness register is cleared.”

Add item after e):

f) After the QAS arbitration delay in step (d), SCSI devices with arbitration fairness enabled which are not arbitrating shall start sampling the DATA BUS to determine which SCSI devices are attempting arbitration, which SCSI device won, and which SCSI devices lost. This sampling shall continue for a bus settle delay plus two system deskew delays. The devices shall update their fairness register with all device IDs that lost in arbitration.

**Accept**

**SPI-3: 137.41) CPQ 140**

Page 101 Section 10.2.2.1

Item b) Change “of a two” to “of two”

**Accept**

**SPI-3: 138.42) CPQ 141**

Page 102 Section 10.3.1

Page 104 Section 10.4.1

Change:

10.3.1 The SCSI device that won the arbitration becomes an initiator by not asserting the I/O signal.

10.4.1 The winning SCSI device becomes a target by asserting the I/O signal.

to:

10.3.1 The SCSI device that won the arbitration identifies itself as an initiator by not asserting the I/O signal.

10.4.1 The SCSI device that won the arbitration identifies itself as a target by asserting the I/O signal.

**Accept**

**SPI-3: 139.43) CPQ 142**

Page 104 Section 10.4

To match the wording in section 10.3:

Change “RESELECTION is a phase that allows” to “The RESELECTION phase allows”

Add a sentence to the end of the paragraph: “During the RESELECTION phase the I/O signal is asserted to distinguish this phase from the SELECTION phase.”

**Accept**

**SPI-3: 140.44) CPQ 143**

Page 113 Section 10.5.2.3

Add a sentence to the end of the section: “The IGNORE WIDE RESIDUE message may be used to indicate that the byte is undefined.” Add similar text for packetized.

**Accept: The wording was changed to:**

**The IGNORE WIDE RESIDUE message may be used to indicate that the last byte of a data field or the data byte of information unit is undefined.**

**SPI-3: 141.45) CPQ 144**

Page 115 Section 10.9.2

Third paragraph. Change “ensures” to “ensure”

Fifth paragraph. Change “transfer at least” to “transferring at least”

**SPI-3: 142.46) CPQ 145**

Page 115 Section 10.8

The last paragraph of 10.8 and the first sentence of section 10.8.1 both imply that the status phase is one byte long. The first two paragraphs don't mention that restriction.

In the first paragraph, change “The STATUS phase allows the target to request that status information” to “The STATUS phase allows the target to request that a status byte”.

**SPI-3: 143.47) CPQ 146**

Page 116 Section 10.9.2

Change “(e.g. ABORT TASK SET” to “(e.g. after receiving ABORT TASK SET”

**SPI-3: 144.48) CPQ 147**

Page 117 Section 11.2.1

Change “is guaranteed to detect” to “detects”

**SPI-3: 145.49) CPQ 148**

Page 120 Section 12.1

Fifth paragraph. Change “an attention setup time” to “an ATN setup time”

Sixth paragraph. Change “information unit and then may” to “information unit, which may”

List of items. Change “If an attention condition is created” to “If an attention condition is detected” in each of a) through g)

Last paragraph: Change “asserted if more than one byte” to “asserted throughout the MESSAGE OUT phase if more than one byte”.

**Accept: Changed 'an attention setup time' to 'an ATN transmit setup time'.**

**SPI-3: 146.50) CPQ 149**

Page 123 Section 13 Last paragraph

Change “Also any” to “Also, any”

Change “BUS FREE phase but many” to “BUS FREE phase, but many”

**Accept**

**SPI-3: 147.51) CPQ 150**

Page 133-134 Section 14.2.1 Table 37, 38

Capitalize task in the header of each table

Use small caps for “task management function not supported” in the last row of table 38

**Reject: Small caps is only used to indicate the proper name of a field.**

**SPI-3: 148.52) CPQ 151**

Page 137 Section 14.2.3 Last paragraph

Use small caps for “iucrc interval” on the first line

Use small caps for “iucrc” on the second line and third line

**Accept**

**SPI-3: 149.53) CPQ 152**

Page 134-140 around Section 14.2

Fix the mixed formatting for “IUCRC” (small caps IU, lower case CRC in several places)

**Reject: The formatting is constant if not strange. In the cases were iuCRC is a field name all the letters are small caps.**

**SPI-3: 150.54) CPQ 153**

Page 145 Section 16.2 Table 49

Page 163 Section 16.3 Table 63

Page 165 Section 16.4 Table 68

Yes: change “message” to “MESSAGE OUT”

Not required: change “message” to “MESSAGE OUT”

n/a: Add “(MESSAGE IN)”

**Accept: Except of the last comment which the editor does not understand.**

**SPI-3: 151.55) CPQ 154**

Page 145 Section 16.2 Table 49

Combine the DISCONNECT IN and OUT rows like MESSAGE REJECT, PPR, SDTR, and WDTR are combined:

04/O/O/DISCONNECT/In/Out/Yes

**Accept**

**SPI-3: 152.56) CPQ 155**

Page 151 Section 16.2.9 Table 55

Change “12.5” to “12,5”

**Accept**

**SPI-3: 153.57) CPQ 156**

Page 170 Section 18.1.1 Second paragraph

Change “manor” to “manner”

**Accept**

**SPI-3: 154.58) CPQ 157**

Page 258 Section L

Change “Integrity Checking” to “Domain Validation” everywhere. This is the marketing term, and is the same term approved for the SCSI Domain Validation technical report which may grow to replace this annex.

**Reject: Domain Validation is a marketing term that has no specific meaning.**

**SPI-3: 155.59) CPQ 158**

Page 258 Section L.1.1

Move NOTE 57 from section L.1.1 to section L.3, which talks about PPR, WDTR, and SDTR.

**Accept**

**SPI-3: 156.60) CPQ 159**

Page 259 Section L.3

Change “parameters for example” to “parameters; for example, “

**Accept**

**SPI-3: 157.61) CPQ 160**

Page 261 Section M.1

Remove the duplicated paragraph.

**Accept**

**SPI-3: 158.62) CPQ 161**

Page 263 Section M.2.2

Change BCH to “Bose, Chaudhuri and Hocquenghem (BCH)”

**Accept**

**SPI-3: 159.63) CPQ 162**

Page 265 Section M.6.1

Change the C code font to a monospace font or manually line up the closing comment markers.

Change “an fifteen” to “a fifteen” near the bottom

**Accept**

**SPI-3: 160.64) CPQ 163**

Page 267 Section M.6.2

Change Verilog to “Verilog® Hardware Description Language (IEEE 1364)”

**Accept**

**Comments from Jie Fan of Madison Cable Corp.:**

**SPI-3: 161.1)**

The current cable performance requirements and its related Annex should be replaced with a newer version of 99-111r7 (for cable requirements) and 98- 219r6 (for Annex)

See comments 33.1 though 96.64.

## Comments from Edward A. Gardner of Ophidian Designs:

### SPI-3: 162.1)

My reasons for abstaining are that I don't feel technically qualified to competently evaluate SPI-3.

Accept

## Comments form Richard Moore of QLogic

### SPI-3: 163.1)

Figure 46: Note 4 says, "VA or VN are required to drive the 100 mV at the leading edge of the transition. Those signals shall be at least |100 mV| for at least tm before and after the transition." First, putting absolute value symbols around a positive number does not change the value of that number. I believe the intended wording is, "The absolute value of those signals shall be at least 100 mV..." Second, it is not clear whether this requirement is on the receiver or on the signal. Is this intended to constrain the system design so that signals not meeting this requirement never occur, or is it intended to constrain the receiver design so that signals meeting this requirement produce a guaranteed response by the receiver? Third, if the signal achieves the 100 mV magnitude, then drops below 100 mV magnitude, then rises above 100 mV magnitude again, all during a single tar or taf period, which crossing of 100 mV magnitude is used for the start of the tm measurement?

Accept: Changing the || to words that state 'The absolute value of...'. Rejected other comments

### SPI-3: 164.2)

Figure 47: Same comment as for Figure 46.

Accept: Changing the || to words that state 'The absolute value of...'. Rejected other comments

### SPI-3: 165.3)

Section 9.3.3, text below Figure 47 on p. 94,: Again, the absolute value symbols are being misused, in "Signals shall remain above the |100 mV| level..." and "The signals shall not drop below |30 mV|..."

Accept: Changing the || to words that state 'The absolute value of...'.

### SPI-3: 166.4)

Section 10.4.1, paragraph 7: Change "physical reconnected" to "physically reconnected". Revision 10 already fixed one instance in the second sentence of this paragraph, but there is a second instance in the third sentence. Also, delete "basically" from "basically reconnected" (or change it to "physically reconnected" if that was intended) in this same sentence.

Accept

### SPI-3: 167.5)

Section 12.1, list item (h): The meaning of the phrase "between SPI information units" is unclear where data stream information units are concerned. This is because the last ACK of the first information unit may occur after the first REQ of the second information unit.

**Reject: The statement in (h) is correct. In the case you describe there is no 'between information units' however that does not make the statement invalid for the times where there is a 'between information units'. Both case have the same effect in that the target will go to a MESSAGE IN at the end of the next information unit.**

### **SPI-3: 168.6)**

Figures 55-58: In transitioning from a SPI information unit to a MESSAGE IN or MESSAGE OUT phase, is it always appropriate for the path to travel through a logical disconnect, as shown? For example, if the message is INITIATOR DETECTED ERROR, shouldn't the logical connection for the message be the same as for the SPI information unit that preceded it?

**Accept: Changed the logical disconnect section as follows. Also updated IU sequence diagrams.**

**SCSI devices using information unit transfers may transfer SPI information units for any number of I/O processes by using logical connects, logical disconnects, and logical reconnects.**

**If there are no phase changes to a MESSAGE OUT phase or a MESSAGE IN phase then logical disconnects shall only occur at the completion of:**

- a) each SPI command information unit;
- b) each SPI status information unit;
- c) each SPI data information unit;
- d) any SPI L\_Q information unit if the SPI L\_Q information unit DATA LENGTH field is zero; and
- e) the last SPI data stream information unit.

**At completion of those SPI information units the I\_T\_L\_Q nexus becomes an I\_T nexus. The I\_T nexus remains in place until the target does a physical disconnect or an I\_T\_L\_Q nexus is reestablished by the target transmitting a SPI L\_Q information unit.**

**Logical reconections occur on the successful target transmission and initiator receipt of a SPI L\_Q information unit for an existing I/O process. The logical reconnection reestablishes the I\_T\_L\_Q nexus for that I/O process.**

**SCSI devices using information unit transfers may receive several commands during an initial connection. This occurs when an initiator uses the multiple command option in the SPI L\_Q information unit. For each SPI L\_Q received with a multiple command type or a last command type a logical connection occurs and an I\_T\_L\_Q nexus is formed.**

**If there is a phase change to a MESSAGE OUT phase or a MESSAGE IN phase then there is no logical disconnect and the I T L Q nexus remains in place. If a DT DATA phase follows the message phase then the L Q portion of the current I T L Q nexus shall be replaced with the L Q in the next SPI L\_Q information unit.**

### **SPI-3: 169.7)**

Annex A, Table A.1: If the minimum terminator bias is 100 mV, and device leakage of up to 20 uA is allowed, then the minimum VN of 100 mV for OR-tied signals cannot be met under these conditions.

**Reject: Will be addressed in SPI-4.**



## Quantum's comments for the letter ballot of SPI-3, rev 10

### **SPI-3: 170.1) Global**

The terms "clause" and "subclause" are used in many places to reference clauses or subclauses elsewhere in the standard. However, these terms are not used consistently. Sometimes just the clause or subclause number to be referenced is used. Sometimes "clause" is used where a subclause is referenced. I think that the terms should be deleted, leaving only the number for reference (e.g., "See x.y for...")

**Accept: Removed the clause or subclause when they proceeded a numbered section. Where they stood alone attempted to make sure clauses where clauses and subclauses where subclauses.**

### **SPI-3: 171.2) Global**

The terms "annex X" and "Annex X" are used inconsistently throughout the standard. I think "Annex X" is correct, but, one way or the other, they should, at least, be consistent.

**Accept: Everything to Annex x.**

### **SPI-3: 172.3) Global**

The terms "cross talk", "cross-talk", and "crosstalk" are used inconsistently throughout the standard. My dictionary says it should be "crosstalk".

**Accept: All to crosstalk.**

### **SPI-3: 173.4) Global**

The term "REQ(ACK)" – and sometimes "REQ (ACK)" – are used in many places where I think the meaning is "REQ or ACK" or "REQ and ACK". I think the single term should be replaced by the correct three-word phrase or defined in 3.1. If defined in 3.1, it would seem to me that then any "REQ or ACK" or "REQ and ACK" in the document should be replaced by "REQ(ACK)".

**Accept: Changed REQ(ACK) to either 'REQ or ACK' or 'REQ and ACK' except where they occurred in the names of timings.**

### **SPI-3: 174.5) Global**

There are many instances where text in a list should be indented. These include: page 1 (PDF page 23), 1 Scope, the list after paragraph 1; page 15 (PDF page 37), 4.3 Physical topologies...; page 21 (PDF page 43), 4.9 Protocol, the list at the bottom of the page; page 23 (PDF page 45), 5.1 SCSI parallel..., the list near the bottom of the clause; page 46 (PDF page 68), two places; etc.

**Accept: All lists are now indented.**

### **SPI-3: 175.6) Quantum # 6. Global**

The symbols "+" and "-" are used in several places and should be replaced by the words "**plus**" and "**minus**" because these symbols are defined as "add" and "subtract" in subclause 3.2 Symbols and abbreviations. I think it also might work to put quotation marks around the symbols in this instance, but that would probably also require additional entries in 3.2 - which is also okay by me. (For examples see page 17 (PDF page 39), 4.4 Bus loading, paragraph 1, and page 52 (PDF page 74), 6.7.1 LVD stub length and spacing). I think should be "System D

Accept

### **SPI-3: 176.7) Global**

The term DATA BUS is used in many places in the document with inconsistent meaning. The definition in 3.2 says "data bus [no caps]..." is an "...8-bit or 16-bit bus." However, on page 79 (PDF page 101), in 8.2 Signal descriptions, I/O:, for example, we find "DATA BUS [the capitalization of this term in the document is inconsistent, as well]". In this particular description I think we mean "...the data bus [as defined in 3.2], P\_CRCA, and P1 (if present for a 16-bit DATA BUS)." On page 87 (PDF page 109), in 9.2.13 Data release delay, I think the same thing is true. I'm not sure exactly how this should be rectified, but a search needs to be performed on all forms of "data bus" and a correct definition included for each case.

**Accept: The term data bus is now DATA BUS in all cases. It is defined as the data bits only (i.e., no P\_CRCA or P1). Where it term data bus included those extra signals they have been explicitly listed. Did I get them all is the question.**

### **SPI-3: 177.8) Quantum # 8. Global**

On page 86 (PDF page 108) 9.2.1 Arbitration delay, the phrase "arbitration has been won" is used. I can't find where in the draft standard that "winning arbitration" or "losing arbitration" are defined. I think the readers should know what these means, but I also think that these concepts are such critical elements of parallel SCSI that the conditions should be specifically defined in this document.

**Accept: How and when a device wins or loses arbitration is defined in the arbitration section of the standard. I have added references to that section.**

### **SPI-3: 178.9) Quantum # 9. Global**

The names of the timing values listed in tables 30, 31, and 32 are used inconsistently throughout the standard. Sometimes the first letter of each word is capitalized and sometimes not. Since these are specific, defined things, I recommend that the first letter of each word be capitalized (e.g., Bus Settle Delay) wherever used. I think this would be more clear.

**Accept: All timings are not capitalized. Except when listed alone when only the first word is capitalized.**

### **SPI-3: 179.10) Quantum # 10. Global**

On page 103 (PDF page 125), 10.3.1.2 Selection without using attention condition, paragraphs 2 and 3, are the words "...an initiator...waits...before...looking..." I think this would be better stated as something like, "...waits before enabling detection..." I think a global search should be performed on "looking" and, where used as above, it should be changed.

**Accept : 'looking for' replaced with 'attempting to detect'.**

### **SPI-3: 180.11) Quantum # 11. Global**

On page 103 (PDF page 125), 10.3.1.2 Selection without using attention condition In this paragraph 4, are the words "a target...shall determine that it is selected..." I think this should be something like, "A target shall be selected when..." I think a global search should be performed on "determine" and, where used as above, it should be changed.

**Accept: Changed to 'detected' or other words where appropriate.**

**SPI-3: 181.12) Quantum # 12. Global**

The phrases "bad parity" and "parity error" are used in many places in the document. I searched on "parity" and found no specific definition for these conditions in the document. Though the definition of these phrases should be intuitive, I think that this is such a critical element of parallel SCSI that the condition should be specifically defined in the document.

**Accept: Added the following to the glossary entry for 'odd parity'**

**If an even number of asserted bits are detected at the receiver a parity error occurs.**

**SPI-3: 182.13) page 1 (PDF page 23), 1 Scope, paragraph 1:**

There should be a colon after the "are" at the end of the first paragraph.

**Accept**

**SPI-3: 183.14) page 3 (PDF page 25), 2.1 Normative references, paragraph 1:**

In the first sentence "...though reference in the text..." should be changed to "...though referenced in the text..."

**Accept**

**SPI-3: 184.15) page 4 (PDF page 26), 2.3 References under development, Note 1:**

Does Global Engineering have copies of draft standards? I would have thought that you would refer folks to the T10 web site for these.

**Yes they do and that is to official way to get standards.**

**SPI-3: 185.16) page 8 (PDF page 30), 3.1.68 physical reconnect:**

In the second sentence, "A target does a physical reconnect..." should be replaced with something like, "A target initiates a physical reconnect..."

**Accept**

**SPI-3: 186.17) page 8 (PDF page 30), 3.1.79, SCSI device:**

"...connect the drivers..." should be replaced with, "...connect its drivers..."

**Accept**

**SPI-3: 187.18) page 9 (PDF page 31), 3.2 Symbols and abbreviations,**

For QAS I think, "Quick Arbitrate and Selection" should be either, "Quick Arbitrate and Select" or, "**Quick Arbitration and Selection**".

**Accept**

**SPI-3: 188.19) page 10 (PDF page 32), 3.3.2 invalid:**

I know it's this way in other standards, but I would change the last words from, "...as error." to, "as an error."

**Accept**

**SPI-3: 189.20) page 10 (PDF page 32), 3.3.5 may not:**

"A keyword..." should be changed to "**Keywords...**" or "A key phrase".

**Accept**

**SPI-3: 190.21) page 11 (PDF page 33), 3.3.8 reserved:**

I know it's this way in other standards, but I would change the last words from, "...as error." to, "as an error."

**Accept**

**SPI-3: 191.22) pages 17 and 18 (PDF pages 39 and 40), 4.7 Data transfers, paragraph 2:**

The following sentence is cumbersome (and "2X" should be replaced unless "two multiply" is meant), "As a result the REQ(ACK) signals rising edge to rising edge time varies by 2X depending on the whether ST or DT transfers are enabled, however the data's transfer rate remains the same." I think this should be changed to something like, "As a result, the time from rising edge to rising edge for REQ and ACK signals for the same transfer rate is twice as long for a DT transfer as it is for an ST transfer."

**Accept**

**SPI-3: 192.23) page 19 (PDF page 41), 4.8 Data transfer modes, paragraph 2:**

The second sentence is in error, "The 8-bit information transfer mode is used for all information transfers except DATA phases." I know this was an oversight on the editor's part, but additional information is transferred on the upper eight bits if AIP is in effect. The sentence could be changed to, "The 8-bit information transfer mode is used for all information transfers except DATA phases (except when an alternate error detection scheme for asynchronous information phases is in effect – see Annex M)."

**Reject: This section does not talk about how error detection works. There is no reference to parity lines or CRC enable lines.**

**SPI-3: 193.24) Quantum # 23. page 42 (PDF page 64),**

5.4.1 SE assignments, Table 5 - SE contact assignments - nonshielded alternative 4 connector, Note 3: This note says, "The pins identified as being short and long only applies to the host connector and not the connector on the SCSI device. All pins on the SCSI device connector are the same length." I think the concept of "host" and "device" used here are a carry overs from previous standards. In figure 15 in this standard (PDF page 29) the terms "device side" and "cable/backplane side" are used. I think these terms are more accurate and the note should use them, as well. (see also page 45 (PDF page 67), 5.4.2 Differential assignments, Table 8 - LVD/MSE contact assignments - nonshielded alternative 4 connector, Note 2:)

**Accept**

**SPI-3: 194.25) page 46 (PDF page 68), 6.1 SCSI bus interconnect overview, paragraph 3:**

"The function of the interconnect is to:" should be changed to, "The functions of the interconnects are to:"

**Accept**

**SPI-3: 195.26) page 50 (PDF page 72), 6.1.3.10 Crosstalk, paragraph 2:**

The terms "DATA" and "PARITY" are introduced in this paragraph with no previous explanation. The previous instance of "DATA" used by itself in this standard referred to a phase. I think most of us understand what is meant here, but that it would be more consistent (and correct) to say something like, "...DATA BUS (8-bit or 16-bit), P\_CRCA, P1 (if present for a 16-bit DATA BUS), and REQ or ACK pairs."

**Accept: Changed to:**

**The aggressor signals are each of the DB(0-15), P\_CRCA, DB(P1), and REQ or ACK pairs. If REQ is the victim line DB(0-15), P\_CRCA, DB(P1), and ACK shall constitute the set of aggressor signals. If ACK is the victim line DB(0-15), P\_CRCA, DB(P1), and REQ constitute the set of aggressor signals.**

**SPI-3: 196.27) page 59 (PDF page 81), Table 19 – SE input voltage characteristics:**

"VIL", VIH", "IIL", and "IIH" need to have their second two letters be subscripts in three places in this table.

**Accept**

**SPI-3: 197.28) Quantum # 27. beginning on page 64 (PDF page 86),**

7.3.2 LVD driver characteristics and on several pages following:

I think the terms "+signal" and "-signal", and "+Signal" and "-Signal" should be replaced with the terms "+SIGNAL" and "-SIGNAL" to be consistent. (See also page 80 (PDF page 102), 7.3.2 LVD signals, several places: The document should be searched for other occurrences of this.

**Accept**

**SPI-3: 198.29) beginning on page 64 (PDF page 86), 7.3.2 LVD driver characteristics and on several pages following:**

The terms "source x" are used in several places in these clauses. This might be clearer if they were capitalized to be "SOURCE x".

**Accept**

**SPI-3: 199.30) Quantum # 29. page 68 (PDF page 90),**

7.3.4.1 Management of LVD release glitches, paragraph 1:

The term "bus settle delay" (that I think should be "Bus Settle Delay") is used for the first time in the document without definition or reference. I would add "(see 9)" after the first time the term is used. Since this is also true for "system deskew delay" (that I think should be "System Deskew Delay") on page 69 (PDF page 91), Table 24 - Glitch management requirements and other timings, I would recommend that some words be added early in clause 7 that say something like, "For specific timing definitions see 9."

**Accept: But no caps used.**

**SPI-3: 200.31) page 69 (PDF page 91), Table 24 – Glitch management requirements..., Note:**

The phrase, “BUS FREE phase starts a Bus Settle Delay after...” should be changed to “A BUS FREE phase starts one Bus Settle Delay after...”

**Accept**

**SPI-3: 201.32) page 75 (PDF page 97), 7.4.2 LVD/MSE multimode transceiver..., paragraph 4:**

The phrase, “A LVD/MSE multimode SCSI device...” should be replaced by, “An LVD/MSE multimode SCSI device...” Strangely enough, I searched the whole document, and this is the only occurrence of this.

**Accept**

**SPI-3: 202.33) page 76 (PDF page 98), 7.4.3 Transceiver ground drivers, paragraph 1:**

The phrase, “...a MSE driver...” should be replaced by, “An MSE driver...” Strangely enough, once again I searched the whole document, and this is the only occurrence of this.

**Accept**

**SPI-3: 203.34) page 78 (PDF page 100), 8.2 Signal descriptions, C/D:**

I don't think the second “CONTROL” should be all caps since it isn't a phase.

**Accept**

**SPI-3: 204.35) page 79 (PDF page 101), 8.2 Signal descriptions, P\_CRCA (data group transfer enabled):**

The term “ULP” is used for the first time here without definition. There are several ways to resolve this, but I think the best would be to add, “(ULP)” after, “upper level protocol” in 3.1.98.

**Accept: Changed ULP to application client.**

**SPI-3: 205.36) Quantum # 35. page 98 (PDF page 120),**

10 SCSI bus phases, paragraph 1:

It says here, "There are eight distinct phases..." (and then the distinct phases are listed). However, later in this clause we find the "NORMAL ARBITRATION phase", "QAS phase", "DT DATA IN phase", "DT DATA OUT phase", "ST DATA IN phase", and "DT DATA OUT" phase. Are these indistinct phases? Somehow I think this needs to be resolved and reconciled in throughout document

**Accept: The offending sentence has been changed to 'The SCSI architecture includes the following phases':**

**SPI-3: 206.37) beginning at page 98 (PDF page 120):**

There are many places where the phrase, "...a [xxx time]..." where [xxx time] is Bus Clear Delay, Bus Settle Delay, etc. I think these should be changed to "...one [xxx time]..." to be more precise.

**Accept**

**SPI-3: 207.38) Quantum # 37. page 98 (PDF page 120),**

10.1.1 Unexpected and expected bus free:

I think it is confusing to mix these conditions in a single subclause. It would be easier for me to read and understand if all of the text related to an expected bus free condition was in 10.1.1 and the text about unexpected bus free was in a new subclause, 10.1.2. This would also, then, make two subclauses instead of one nested under 10.1 which is a more common style.

**Accept: The expected list is now in a separate section.**

**SPI-3: 208.39) Quantum # 38. page 99 (PDF page 121),**

10.2 Arbitration, paragraph 2:

There is a semicolon in the first sentence that I think should be a colon.

**Accept**

**SPI-3: 209.40) Quantum # 39. page 99 (PDF page 121),**

10.2.1 NORMAL ARBITRATION phase,

first list: Item (c) says, "...the SCSI device shall not arbitrate (i.e. assert the BSY signal and its SCSI ID) if more than a bus set delay has passed since the BUS FREE phase was last observed." However, Note 23 immediately following says,

"There is no maximum delay before asserting the BSY signal and the SCSI ID following the bus free delay in step (b)." I may be missing something, but this looks like a contradiction to me.

**No Change: The statement and the note are correct. The item states '.. since the BUS FREE phase was last observed' and the note states '...as long as the bus remains in the BUS FREE phase. ' that is the difference. In other words if no one starts arbitrating for the bus there is no time limit but once one device starts (i.e., the bus is no longer in bus free state) the timer starts.**

**SPI-3: 210.41) Quantum # 40. page 108 (PDF page 130),**

10.5.2.2.1 Information unit transfer, first item in the third numbered list on the page:

I think that, "Shall after detecting a REQ transition;" should be changed to, "Shall wait until detecting a REQ transition;" (See also the first item in the third numbered list on page 110 (PDF page 132)).

**Accept**

**SPI-3: 211.42) Quantum # 41. page 111 (PDF page 131),**

10.5.2.2.2.2 Data Group Pad field and pCRC field transfer to target:

The first sentence of the first paragraph is not a complete sentence (i.e., "If the I/O signal is false (transfer to the target) and the initiator determines the data field transfer is complete by detecting an assertion of the P\_CRCA signal.") I think the "and" in the sentence should be removed.

**Accept**

**SPI-3: 212.43) Quantum # 42. page 143 (PDF page 165),**

16.1.2.2 Two-byte messages:

The first sentence of this says, "Two-byte messages consist of two consecutive bytes transferred during two consecutive MESSAGE IN phases or two consecutive MESSAGE OUT phases." but 16.1.1 says, "...a message shall not be split between multiple MESSAGE phases." I think the sentence in 16.1.2.2 should be changed to, "Two-byte messages consist of two consecutive bytes transferred during a MESSAGE IN phase or a MESSAGE OUT phase." (See also the first sentence in 16.1.2.3 Extended messages.)

**Accept**

**SPI-3: 213.44) Quantum # 43. Annex E:**

All of the figures in this Annex (except E.6) are at least somewhat blurry (they look even worse in my printed version of the PDF). Is there anything that can be done about this?

**The editor can only work with what he receives. This is especially true when it comes to complex figures. However, on review the PDF on my machine the figures do not appear to be all that bad.**

**SPI-3: 214.45) Quantum # 44. Annex M, M.1, paragraphs 1 and 2:**

Paragraphs 1 and 2 are identical. Even though I like to see my words in print, one of these paragraphs should be deleted.

**Accept**

**Comments accompanying Gene Milligan's SPI-3 Rev 10 Letter Ballot 10/28/99**

From an overall standpoint SPI-3 is in good shape and will be ready for forwarding when the letter ballot resolution is complete. The following comments are in order of occurrence in the draft. The labels are an artifact of the software used for the review.

**SPI-3: 215.1) Page 16**

Note 1; Label: Gene Milligan; Date: 10/15/99 2:38:49 PM

1) When does the revision history get deleted?

**That would be rev 11**

**SPI-3: 216.2) Page 21**

Note 1; Label: Gene Milligan; Date: 10/15/99 2:43:04 PM

2) Do we still like the name of T10 as shown on page 21? Note in these comments all page numbers are



pdf page numbers.

**As far as I know that is still what we are called.**

**SPI-3: 217.3) Page 22**

Note 1; Label: Gene Milligan; Date: 10/15/99 2:46:45 PM

3) I think the Introduction is where the Clauses should be listed. Not the foreword.

**Accept**

**SPI-3: 218.4) Page 23**

Note 1; Label: Gene Milligan; Date: 10/15/99 2:52:40 PM

4) In the scope "Properly conforming" should be changed to "Conforming" since implementations are either conforming or they are not conforming. The standard does not define what is proper. It only defines what is conformant.

**Accept**

**SPI-3: 219.5) Note 2; Label: Gene Milligan; Date: 10/15/99 2:56:44 PM**

5) <<Distributed arbitration (i.e., bus-contention logic) is built into the architecture of SCSI.>> I think this should be changed to "Distributed arbitration (i.e., bus-contention logic) is built into the architecture of SPI." Or of this standard.

**Accept**

**SPI-3: 220.6) Page 25**

Note 1; Label: Gene Milligan; Date: 10/15/99 3:18:49 PM

6) There are no normative requirements in SPI-3 referencing SCSI-2. Why is it a normative reference?

**Accept**

**SPI-3: 221.7) Page 26**

Note 1; Label: Gene Milligan; Date: 10/19/99 5:04:34 PM

7) Why is VHDCI called out both as an approved reference and as an other reference?

**Accept: Removed 'other reference'.**

**SPI-3: 222.8) Note 2; Label: Gene Milligan; Date: 10/27/99 6:42:55 PM**

8) The definition of asynchronous transfer also fits synchronous transfers. There should be a distinction such as "with an offset of zero"

**Accept**

**SPI-3: 223.9) Page 27**

Note 1; Label: Gene Milligan; Date: 10/27/99 6:43:10 PM

9) The contingent allegiance definition should be changed from "One of the conditions" to "An optional condition".

**Accept**

**SPI-3: 224.10) Page 28**

Note 1; Label: Gene Milligan; Date: 10/25/99 5:06:28 PM

10) With the step forward to "a SCSI" why "an SPI L\_Q".

**Accept made it a SPI.**

**SPI-3: 225.11) Note 2; Label: Gene Milligan; Date: 10/27/99 6:43:31 PM**

11) In 3.1.39 the underlines are missing for I\_T nexus and I\_T\_L nexus.

**There are underlines in the frame version and the pdf versions.**

**SPI-3: 226.12) Page 31**

Note 1; Label: Gene Milligan; Date: 10/27/99 6:43:45 PM

12) <<A task causes the nexus to be generated.>> or is it vice versa?

**Accept: The statement 'A task causes the nexus to be generated.' does not appear to add any value therefore it has been removed.**

**SPI-3: 227.13) Page 32**

Note 1; Label: Gene Milligan; Date: 10/25/99 5:10:15 PM

13) In 3.3.2 change <<shall be reported as error.>> to "shall be reported as an error." Adding the "an" to this phrase is a global change.

**Accept**

**SPI-3: 228.14) Page 33**

Note 1; Label: Gene Milligan; Date: 10/26/99 11:19:55 AM

14) I prefer "reserved: A keyword indicating reserved bits, bytes, words, fields, and code values that are set aside for future standardization. Their use and interpretation may be specified by future extensions to this or other standards. A reserved bit, byte, word, or field shall be set to zero, or in accordance with a future extension to this standard. The recipient shall not check reserved bits, bytes, words, or fields. Receipt of reserved code values in defined fields shall be reported as an error."

**Partial accept: the statement 'The recipient shall not check reserved bits, bytes, words, or fields.' was not accepted as it has been rejected in the past. (GOP - needs further discussion).**

**SPI-3: 229.15) Note 2; Label: Gene Milligan; Date: 10/25/99 5:11:20 PM**

15) Since the construction of lists, thankfully does not follow the ANSI style guide, the convention for ordered lists, non-ordered lists, and mixed lists should be added.

**Accept: Added in the following:**

**An alphanumeric list (e.g., a,b,c or A,B,C) of items indicate the items in the list are unordered.**

**A numeric list (e.g., 1,2,3) of items indicate the items in the list are ordered (i.e., item 1 must occur or complete before item 2).**

**SPI-3: 230.16) Note 3; Label: Gene Milligan; Date: 10/26/99 11:20:11 AM**

16) In 3.5 the separators would be clearer if they were taller.

**Accept**

**SPI-3: 231.17)**

17) The use of <<input-1a and input-1b>> is not explained as the stated convention causes the reader to expect "input-1 and input-2".

**Accept: Changed - to :. But the convention is described right below the expression.**

**SPI-3: 232.18) Page 35**

Note 1; Label: Gene Milligan; Date: 10/25/99 5:11:46 PM

18) In 4 change <<This standard defines the cables, connectors, signals, transceivers, and protocol used to interconnect SCSI devices ...>> to "This standard defines the cables, connectors, signals, transceivers, and protocol used to interconnect parallel SCSI devices ..."

**Accept**

**SPI-3: 233.19)**

19) Consider eliminating hanging paragraphs.

**Accept**

**SPI-3: 234.20) Note 2; Label: Gene Milligan; Date: 10/26/99 11:20:22 AM**

20) Table 1 is a little misleading. It infers there are two types of LVD transceivers for (ST) and (DT). Actually the LVD transceivers can be used for both ST and DT. Probably ST and DT should be eliminated from the Transceiver column and added to the Async and Fast-80 columns.

**Accept: Added a new column labeled 'data latching (ST/DT)'**

**SPI-3: 235.21) Note 3; Label: Gene Milligan; Date: 10/25/99 10:22:38 AM**

21) Stub connections in 4.2 should have a forward reference to figure 4.

**Accept**

**SPI-3: 236.22) Page 37**

Note 1; Label: Gene Milligan; Date: 10/25/99 5:13:13 PM

22) <<SCSI bus connectors shall be defined by their function and by their physical placement.>> should be changed to "SCSI bus connectors are defined by their function and by their physical placement." since as presently stated it is a requirement for the editor not for the implementor.

**Accept**

**SPI-3: 237.23) Note 2; Label: Gene Milligan; Date: 10/25/99 5:13:22 PM**

23) <<d) connectors physically part of enclosures are enclosure connectors, and>> is not clear to me since all the other connectors mentioned, if in an enclosure, are part of an enclosure (the inside parts). Was this item intended to specify the connectors entering and exiting the enclosure?

**Accept: Changed as follows:**

- f) connectors that provide entry and exit points to and from enclosures are labeled enclosure connectors, and

**SPI-3: 238.24) Page 38**

Note 1; Label: Gene Milligan; Date: 10/25/99 5:14:12 PM

24) Under Figure 4 <<If an intermediate interconnection is added to connect the SCSI device to the bus path this additional interconnect (including its connectors) and both SCSI devices contribute to the stub and bus loading. In system implementations that use an intermediate interconnect the parameters specified in this standard at the SCSI device connector shall apply at the stub connection.>> is confusing. "both SCSI devices" should be referring to a single SCSI device.

**Accept: Changed 'both SCSI devices' to 'the SCSI device'.**

**SPI-3: 239.25) Page 39**

Note 1; Label: Gene Milligan; Date: 10/25/99 5:14:19 PM

25) In 4.4 two terms are used for the same thing:

<<Bus termination circuitry bus loading>>

<<Bus termination loading>>

Pick one.

**Reject: Bus termination circuitry is the cause of the bus termination loading and a component of bus loading. Although confusing it appears to be correct**

**SPI-3: 240.26) Note 2; Label: Gene Milligan; Date: 10/25/99 5:14:48 PM**

26) In 4.6 I think <<the width of the data path on the bus;>> should be "the width of the data path of the bus;"

**Accept**

**SPI-3: 241.27) Note 3; Label: Gene Milligan; Date: 10/25/99 5:14:58 PM**

27) In 4.7 since the ST technique is used in all phases except DT data phases <<When ST DATA phases are used data is only latched on the asserting edge of the REQ(ACK) signal.>> should be changed to "Data shall only be latched on the asserting edge of the REQ(ACK) signal except in DT DATA phases." and change <<When DT DATA phases are used, data is latched on both the asserting edge and the negating edge of the REQ(ACK) signal.>> to "When DT DATA phases are used, data shall be latched on both the asserting edge and the negating edge of the REQ(ACK) signal."

**Accept**

**SPI-3: 242.28) Page 42**

Note 1; Label: Gene Milligan; Date: 10/25/99 5:17:58 PM

28) In 4.8 last line <<before each interval iuCRC is transmitted.>> should be "before each iuCRC interval, iuCRC is transmitted." for consistency.

**Accept**

**SPI-3: 243.29) Page 43**

Note 1; Label: Gene Milligan; Date: 10/25/99 5:25:07 PM

29) Under figure 9 change <<The SCSI parallel interface service interface consists of the following interactions:>> to "The SCSI parallel interface four step confirmed service protocol consists of the following interactions:"

**Accept**

**SPI-3: 244.30) Page 44**

Note 1; Label: Gene Milligan; Date: 10/25/99 5:26:23 PM

30) Under figure 10 change <<The SCSI parallel interface service interface consists of the following interactions:>> to "The SCSI parallel interface two step confirmed service protocol consists of the following interactions:"

**Accept**

**SPI-3: 245.31) Page 45**

Note 1; Label: Gene Milligan; Date: 10/25/99 5:30:24 PM

31) Consider using IEC specifications rather than EIA.

**Accept: Changed all normative references to ISO in section 2.**

**SPI-3: 246.32) Note 2; Label: Gene Milligan; Date: 10/25/99 5:33:31 PM**

32) In 5.1 change <<c) Contact resistance is measured in accordance with item a) above (this is an optional step);>> to "c) Measure contact resistance in accordance with item a) above (this is an optional

step);"

**Accept**

Should <<a>> be "(a)"?

**Accept: Yes**

**SPI-3: 247.33) Page 46**

Note 1; Label: Gene Milligan; Date: 10/25/99 5:43:22 PM

33) In 5.2.4 change <<see the SCA-2 E I A speci f i cation EIA-700A0AE.>> to "see the SCA-2 EIA stan-  
dard EIA-700A0AE." The change from specification to standard is global.

**Accept**

**SPI-3: 248.34) Note 2; Label: Gene Milligan; Date: 10/25/99 5:45:14 PM**

34) Why are we seeing SFF-8451?

**Because there is information in SFF-8451 that does not exist anywhere else. For the ISO version of SPI-2 we moved this information into an annex but no such request has been made for SPI-3.**

**SPI-3: 249.35) Page 59**

Note 1; Label: Gene Milligan; Date: 10/25/99 6:02:28 PM

35) The drafting standard used for figures 11-13, 17-19, and 21-22 should be added to the normative refer-  
ences (preferably the international version).

**Reject: If I have such a thing I would. But we have several standards that are now ISO that have these same figures and have not had any requests for a reference to a standard.**

**SPI-3: 250.36) Page 62**

Note 1; Label: Gene Milligan; Date: 10/25/99 6:20:09 PM

36) In the notes of the tables in 5.4 shouldn't <<2 The minus sign next to a signal indicates active  
low.>> be "2 The minus sign next to a signal indicates asserted low."?

**Accept**

**SPI-3: 251.37) Page 64**

Note 1; Label: Gene Milligan; Date: 10/25/99 6:17:40 PM

37) In table 5 <<3 The pins identified as being short and long only applies to the host connector and not the  
connector on the SCSI device.>> should be "3 The pins identified as being short and long only applies to  
the mating cable stub connector (i.e., backplane connector and not the connector on the SCSI device."

**Accept: See comment SPI-3: 190.21)**

**SPI-3: 252.38) Page 68**

Note 1; Label: Gene Milligan; Date: 10/25/99 6:31:58 PM

38) As commented previously <<The interconnect shall ensure that worst case transmitted signals result in received signals that meet the requirements contained in clause 7.>> should be "The interconnect shall meet the specified characteristics to ensure that compliant worst case transmitted signals result in received signals that meet the requirements in clause 7."

**Accept**

**SPI-3: 253.39) Note 2; Label: Gene Milligan; Date: 10/25/99 6:37:17 PM**

39) 6.2 states <<b) In the P cable, if there are more than three conductor pairs in the cable core, conductor pairs #47-48 (ACK) and #57-58 (REQ) shall not be adjacent to each other;>> In a round cable with four pairs in the core is this possible? It is clearly possible if it is a twisted flat. But in a round cable it seems like all four could be adjacent to the other three.

**Accept; Change 'three conductor pairs' to 'four conductor pairs'**

**SPI-3: 254.40) Note 3; Label: Gene Milligan; Date: 10/25/99 6:41:35 PM**

40) <<f) Each cable conductor pair shall consist of the signal return and its associated signal.>> should be "f) Each cable conductor pair shall consist of the signal return and its associated signal for single ended applications or signal minus and its associated signal plus for differential applications.

**Accept**

**SPI-3: 255.41) Note 4; Label: Gene Milligan; Date: 10/25/99 6:43:46 PM**

41) <<(clocks in the center, data around the periphery)>> should be (REQ and ACK in the center, data around the periphery)"

**Accept**

**SPI-3: 256.42) Page 69**

Note 1; Label: Gene Milligan; Date: 10/25/99 6:52:10 PM

42) Clause 6.2 stated that all interconnects are required to meet <<a) transmission line impedance (see 6.3);

- b) propagation delay (see 6.3);
- c) cumulative length (see 6.6 and 6.7); and
- d) signal attenuation (see 6.3).>>

Clause 6.3.1 seems to state that only uniform media is required to meet the requirements of 6.3.

<<The requirements in this clause apply to uniform cable media.>> The two subclauses are in conflict.

**Accept: See SPI-3: 44.12)**

**SPI-3: 257.43) Page 70**

Note 1; Label: Gene Milligan; Date: 10/26/99 11:21:33 AM

43) What does note 3 of Table 9 mean? <<3 The conductor size recommendations assume voltage drops only due to the cables (i.e., does not include voltage drops due to connectors, ground effects. etc.)>>. That the recommended wire sizes are invalid since there are no applications without connectors.

**I don't know but the note is now gone along with the table. Table 11 has replaced it. See comment SPI-3: 35.3) and SPI-3: 39.7).**

**SPI-3: 258.44) Note 2; Label: Gene Milligan; Date: 10/25/99 7:02:40 PM**

44) Table 10 should include units (i.e., Ohms). In note 3 shouldn't ohms be capitalized in respect to old man Ohm or the symbol in homage to the Greeks? If so, it is global.

**Accept**

**SPI-3: 259.45) Page 71**

Note 1; Label: Gene Milligan; Date: 10/26/99 11:21:44 AM

45) <<variation of 30 ohms over the frequency range 1 MHz to 1 GHz on a 30 meter cable.>> Does that mean there is no requirement for a compliant cable (i.e., =< 25 meters)? Should this be "variation of 30 ohms over the frequency range 1 MHz to 1 GHz on a 30 meter cable media sample."?

**Accept: yes see comment SPI-3: 37.5).**

**SPI-3: 260.46) Note 2; Label: Gene Milligan; Date: 10/26/99 11:29:39 AM**

46) The first paragraph in 6.3.7 repeats the requirements of 6.3.6.

The or choice for total delay for a cable instead of per foot is tolerable. But this choice for differential delay is onerous. Allowing the choice of the total differential delay for 25 meter point to point cables for shorter cable multi-drop applications unnecessarily squeezes the budget for 12 meter applications by 1 ns. If the "or" requirement is to be maintained it should be divided into three values (i.e., 6, 12, and 25 meters) or four values (i.e., 3, 6, 12, and 25 meters).

**Accept: 6.3.3 replaced with wording from comment 43.11.**

**SPI-3: 261.47) Page 72**

Note 1; Label: Gene Milligan; Date: 10/26/99 11:32:38 AM

47) In 6.3.10 what does <<measured at a time position not associated with the test fixture>> mean? Since the test fixturing is for the purpose of measuring crosstalk the maximum crosstalk will be associated with the test fixture.

**I don't know (GOP- needs discussion)**

**SPI-3: 262.48) Note 2; Label: Gene Milligan; Date: 10/26/99 11:33:56 AM**

48) In note 5 change <<at 1963 mV peak-to-peak p aggressor signal amplitude>> to "at 1 963 mV peak-to-peak aggressor signal amplitude"

**Accept**



**SPI-3: 263.49) Page 73**

Note 1; Label: Gene Milligan; Date: 10/26/99 11:44:03 AM

49) In table 13 why is there both note 1 and note 3? Note 1 includes the concept of note 3.

In table 13 and in table 14 add to the remaining note or both notes "If the maximum cable requirements are exceeded, SCSI devices shall not be required to conform to the electrical and timing requirements of this standard.

**I don't know and the requested change has not been made. (GOP- needs discussion)**

**SPI-3: 264.50) Page 76**

Note 1; Label: Gene Milligan; Date: 10/26/99 11:48:04 AM

50) In 7.1 soften <<If a mode change occurs the SCSI bus is not operational until all SCSI devices and terminators have changed modes.>> to "If a mode change occurs the SCSI bus is not operational until all multi-mode SCSI devices and all terminators have changed modes and all other SCSI devices have released the SCSI bus."

**Accept**

**SPI-3: 265.51) Page 78**

Note 1; Label: Gene Milligan; Date: 10/26/99 12:04:07 PM

51) Regarding 7.2.1 <<Terminators employing a 220 ohm resistor to 5 volts and a 330 ohm resistor to ground shall not be used.>> we knew what we meant, but shouldn't this be "Terminators employing a resistor divider network between 5 volts and ground as the termination shall not be used."

**Accept**

**SPI-3: 266.52) Note 2; Label: Gene Milligan; Date: 10/26/99 12:39:15 PM**

52) In table 18 change the note <<SE steady state output voltage characteristics specified by

maximum transfer rate shall apply even if a slower transfer rate is negotiated.>> to "SE steady state output voltage characteristics specified by maximum transfer rate shall apply according to the driver type." Better yet, delete the note.

**Accept: Note deleted**

**SPI-3: 267.53) Note 3; Label: Gene Milligan; Date: 10/26/99 12:42:31 PM**

53) Change <<The output characteristics (signal negated) for active-negation drivers shall be

constrained to operate in the non-shaded areas of figure 26 for fast-20 SCSI devices and are recommended for all others.>> to "The output characteristics (signal negated) for active-negation drivers shall be constrained to operate in the non-shaded areas of figure 26 for SE SCSI devices that support fast-20 and are recommended for all other SE SCSI devices."

**Accept**

**SPI-3: 268.54) Page 81**

Note 1; Label: Gene Milligan; Date: 10/26/99 12:57:36 PM

54) In 7.2.3 the table does not use subscripts and the text does. Since the text takes precedence change the table to use subscripts.

**Accept**

**SPI-3: 269.55) Page 82**

Note 1; Label: Gene Milligan; Date: 10/26/99 1:03:38 PM

55) Wherever the note <<SE input and output voltage characteristics specified by the maximum transfer rate shall apply even if a slower transfer rate is negotiated.>> is valid should be changed to "SE input and output voltage characteristics specified by the maximum transfer rate supported shall apply even if a slower transfer rate is negotiated." (e.g., Table 20).

**Accept**

**SPI-3: 270.56) Page 83**

Note 1; Label: Gene Milligan; Date: 10/26/99 1:19:48 PM

56) Below figure 29 remove the redundancy from <<Figure 30 and table 21 show the allowed ranges for I diff and V diff in figure 29. The requirements that relate to differential impedance are specified in figure 30 and table 21. Table 21 specifies the allowed ranges for I diff and V diff in figure 29.>> I think this is done by deleting the third sentence. The second sentence should be deleted in favor of the same sentence below Figure 31. Should it however be figure 31 and should figure 30 be mentioned in each of these cases?

**Accept: There were some problems with the cross-references and there was some duplicate text. All has been fixed.**

**SPI-3: 271.57) Page 85**

Note 1; Label: Gene Milligan; Date: 10/26/99 1:24:28 PM

57) Below Table 21 delta V does not need to be identified as being in figure 31 twice in the same paragraph.

**Accept**

**SPI-3: 272.58) Page 86**

Note 1; Label: Gene Milligan; Date: 10/26/99 1:28:37 PM

58) In table 22 the Value column should be labeled parameter and the LVD column should be labeled Value.

**Not sure about that (GOP - Needs discussion)**

**SPI-3: 273.59) Page 94**

Note 1; Label: Gene Milligan; Date: 10/26/99 2:05:08 PM

59) Regarding <<NOTE 11 - The DIFFSENS voltage filter time delay allows time for the DIFFSENS pin to connect after the initial power connection (in the case of insertion of a SCSI device into an active system), or allows time for the power distribution system to settle.>> there is no concept of DIFFSENS disconnecting. "connect" should be changed to "settle".

**Accept**

**SPI-3: 274.60) Note 2; Label: Gene Milligan; Date: 10/26/99 2:11:15 PM**

60) Change <<A SCSI device shall change to the new signal driver or receiver mode based on the DIFFSENS voltage level within 400ms of the last DIFFSENS voltage change regardless of the DIFFSENS voltage filter time.>> to "A multimode SCSI device shall change to the new signal driver or receiver mode based on the DIFFSENS voltage level within 400ms of the last DIFFSENS voltage change regardless of the DIFFSENS voltage filter time. Devices not capable of the new mode shall release the SCSI bus and remain in the high impedance state after the DIFFSENS voltage filter time."

**Accept**

**SPI-3: 275.61) Page 95**

Note 1; Label: Gene Milligan; Date: 10/26/99 2:26:16 PM

61) Wherever <<DIFFSENS voltage filter time>> is first used in a subclauses a forward reference to the specified time should be given to prevent designers from concluding this is a vendor specific time.

**Accept**

**SPI-3: 276.62) Page 96**

Note 1; Label: Gene Milligan; Date: 10/26/99 2:32:18 PM

62) Why is <<NOTE 13 - The +SIGNAL line and -SIGNAL line capacitance should be balanced on disabled terminators.>> not also in the LVD terminator clause.

**I don't know and no change has been made. (GOP- needs discussion)**

**SPI-3: 277.63) Note 2; Label: Gene Milligan; Date: 10/26/99 2:43:14 PM**

63) Change <<Multimode termination is not recommended for HVD environments unless the common mode voltages in the environment are controlled to safe levels for SE and LVD SCSI devices (see table 16 and table 17).>> to "Multimode termination is not recommended for environments with common mode voltages exceeding the safe levels for SE and LVD SCSI devices (see table 16 and table 17)." Make this same wording change to 7.4.2.

**Accept**

**SPI-3: 278.64) Note 3; Label: Gene Milligan; Date: 10/26/99 2:41:19 PM**

64) Delete <<NOTE 14 - When using only the SCA-2 connector (see 5.2.4) the SE, LVD, and HVD connector contact numbers allow switching between all three modes. In this case the terminator may switch to HVD mode if so indicated by the DIFFSENS line.>> or change it to "NOTE 14 - When using only the SCA-2 connector (see 5.2.4) the SE, LVD, and HVD connector contact numbers allow switching between all three modes. In this case the terminator may switch to HVD mode if so indicated by the DIFFSENS line and the SCSI devices should be replaced with HVD SCSI devices."

**Reject: We have no control over irrational behavior.**

**SPI-3: 279.65) Page 98**

Note 1; Label: Gene Milligan; Date: 10/26/99 2:57:46 PM

65) I think <<NOTE 16 - The disabled ground driver capacitance should match the capacitance of the disabled assertion and negation drivers.>> is wrong. The note should be deleted or changed to "NOTE 16 - The disabled ground driver capacitance is a factor in meeting the capacitance requirements of table 23."

**Accept**

**SPI-3: 280.66) Page 99**

Note 1; Label: Gene Milligan; Date: 10/26/99 3:06:53 PM

66) It should be well known that repeating requirements as is done rather frequently in SPI-3 (probably also in SPI-2) leads to the danger of conflicting requirements. An example of this is in 7.5 <<Direct connection between the TERMPWR source and the individual terminators without using the TERMPWR line is also allowed.>> This is in direct conflict with an earlier clause that allowed additional power sources but required the terminator to also use the TERMPWR line as a source.

**Accept - Made term power wording consistent . Selected the option 'Direct connection between the TERMPWR source and the individual terminators without using the TERMPWR line is also allowed'. (Made change on page 55)**

**SPI-3: 281.67) Note 2; Label: Gene Milligan; Date: 10/26/99 4:50:04 PM**

67) Regarding <<The TERMPWR lines may be used for distribution of power for purposes other than for SCSI bus termination as long as the voltage delivered to the SCSI bus terminators remains adequate to supply the requirements of the terminators under all conditions of SCSI bus operation and under all conditions of other loading.>> This should be deleted or a current limit added. I will open the bidding at 0 amps.

**Reject - Not change made**

**SPI-3: 282.68) Page 100**

Note 1; Label: Gene Milligan; Date: 10/26/99 4:52:39 PM

68) In clause 8.1 change <<The maximum number of SCSI devices is determined by the width of the data path implemented.>> to "The maximum number of SCSI devices is determined by the width of the data path implemented and restrictions in clause 7."

**Accept**

**SPI-3: 283.69) Note 2; Label: Gene Milligan; Date: 10/26/99 4:56:35 PM**

69) Above table 28 expand <<Table 28 shows the relationship between SCSI Addresses, SCSI IDs, and arbitration priority. In table 28 a hyphen ("-") represents a logical zero bit.>> to "Table 28 shows the relationship between SCSI Addresses, SCSI IDs, and arbitration priority. In table 28 a hyphen ("-") represents a logical zero bit resulting from the data bus bit being released."

**Accept**

**SPI-3: 284.70) Page 101**

Note 1; Label: Gene Milligan; Date: 10/26/99 5:03:58 PM

70) Change <<P\_CRCA (PARITY/CRC AVAILABLE) (ST DATA phase, COMMAND phase, MESSAGE phase, or STATUS phase). A signal sourced by the SCSI device driving the data bus during these phases. This signal is associated with the DB(7-0) signals and is used to detect the presence of an odd number of bit errors within the byte. The parity bit is driven such that the number of logical ones in the byte plus the P\_CRCA bit is odd.>> to "P\_CRCA (PARITY/CRC AVAILABLE) (ST DATA phase, COMMAND phase, MESSAGE phase, or STATUS phase). A signal sourced by the SCSI device driving the data bus during these phases. This signal is associated with the DB(7-0) signals and is used to detect the presence of an odd number of bit errors within the byte. The P\_CRCA bit is driven such that the number of logical ones in the byte plus the P\_CRCA bit is odd."

**Accept**

**SPI-3: 285.71) Note 2; Label: Gene Milligan; Date: 10/26/99 5:47:52 PM**

71) Change <<P1 (ST DATA phase). A signal sourced by the SCSI device driving the data bus during ST DATA phases. This signal is associated with the DB(15-8) signals and is used to detect the presence of an odd number of bit errors within the byte. The parity bit is driven such that the number of logical ones in the byte plus the parity bit is odd.>> to "P1 (ST DATA phase). A signal sourced by the SCSI device driving the data bus during ST DATA phases. This signal is associated with the DB(15-8) signals and is used to detect the presence of an odd number of bit errors within the byte. The P1 bit is driven such that the number of logical ones in the byte plus the P1 bit is odd."

**Accept**

**SPI-3: 286.72) Page 109**

Note 1; Label: Gene Milligan; Date: 10/26/99 6:35:17 PM

72) In 9.2.16 change <<(See SCSI Primary Commands-2 Standard).>> to "(**See SCSI Primary Commands-2 standard**)." or "(See SCSI Primary Commands-2)." or "(See SPC-2). This is a global change. (The first choice is the way SAM-2 is handled.

**Accept**

**SPI-3: 287.73) Page 110**

Note 1; Label: Gene Milligan; Date: 10/26/99 6:49:02 PM

73) Expand <<9.2.25 Receive REQ (ACK) period tolerance The minimum tolerance that a SCSI device shall allow to be subtracted from the REQ (ACK) period.>> to "9.2.25 Receive REQ (ACK) period tolerance The minimum tolerance that a SCSI device shall allow to be subtracted from the REQ (ACK) period. The tolerance comprises the Transmit REQ (ACK) tolerance plus a measurement error due to noise."

**Accept**

**SPI-3: 288.74) Note 2; Label: Gene Milligan; Date: 10/26/99 6:49:09 PM**

74) Change <<9.2.27 Receive REQ negation period with P\_CRCA transitioning The minimum time required at a SCSI device receiving an REQ signal>> to "9.2.27 Receive REQ negation period with P\_CRCA transitioning. The minimum time required at a SCSI device receiving a REQ signal"

**Accept**

**SPI-3: 289.75) Note 3; Label: Gene Milligan; Date: 10/26/99 6:53:33 PM**

75) In 9.2.28 change <<since data is only qualified the assertion edge of the REQ (ACK) signal.>> to "since data is only qualified on the assertion edge of the REQ (ACK) signal."

**Accept**

The proposal, that was accepted for DT added the definition of REQ (ACK) period. It included the measurement concept of using a regular signal (without offsets) to measure the time to avoid ISI.

That concept seems to have disappeared and should be restored.

**Reject for now: That may be the case, however, without the words to add no changes will be made. (GOP - needs discussion)**

**SPI-3: 290.76) Page 116**

Note 1; Label: Gene Milligan; Date: 10/26/99 7:54:50 PM

76) Under figure 47 what does <<This sets up an environment where the short REQ or ACK pulses may not have adequate timing margin unless the definitions in figure 46 and figure 47 are used in the measurement of timing parameters.>> mean? The definitions will not increase the timing margin of real signals. They will either have margin or they will not.

**I don't know and no change has been made. (GOP- needs discussion)**

**SPI-3: 291.77) Note 2; Label: Gene Milligan; Date: 10/26/99 8:01:20 PM**

77) Regarding << Measurement of driver timing parameters shall be performed using the circuit and test conditions defined in A.2.5 applied to the SCSI device connector. Receiver timing parameters are defined by the waveforms existing at the connector of the receiving SCSI device.>> Isn't the second sentence completely redundant to the first.

**Possibly but no change has been made. (GOP- needs discussion)**

**SPI-3: 292.78)**

78) What does <<The receiver timing parameters include the effects of data pattern. The receiver data pattern is therefore not defined.>> mean?

**I don't know and no change has been made. (GOP- needs discussion)**

**SPI-3: 293.79) Page 121**

Note 1; Label: Gene Milligan; Date: 10/26/99 8:18:28 PM

79) in 10.2 change <<QAS is optional and, when enabled, requires the detection of a QAS REQUEST message (see 16.2.10) before starting.>> to "QAS is optional and, when enabled, requires the initiation and detection of a QAS REQUEST message (see 16.2.10) to start."

**Accept**

**SPI-3: 294.80) Note 2; Label: Gene Milligan; Date: 10/26/99 8:27:20 PM**

80) <<however the SCSI device shall not arbitrate (i.e. assert the BSY signal and its SCSI ID) if more than a bus set delay has passed since the BUS FREE phase was last observed.>> This sounds like a deadly embrace. It should probably be changed to (comma for sure) "however the SCSI device shall not arbitrate (i.e., assert the BSY signal and its SCSI ID) if more than a bus set delay has passed since the BUS FREE phase was last observed and the SCSI bus is not BUS FREE."

**Reject: (Except the comma). The may appear to be bus free but it may not be because of propagation delays on the singles. If we make this change the max timing (i.e., bus set delay) is meaningless.**

**SPI-3: 295.81) Page 122**

Note 1; Label: Gene Milligan; Date: 10/26/99 8:38:04 PM

81) Regarding <<10.2.2 QAS protocol QAS allows a target that has information unit transfers enabled and QAS enabled that is currently connected to an initiator that has information unit transfers enabled and QAS enabled to transfer control of the bus to another SCSI device that has information unit transfers enabled and QAS enabled without an intervening BUS FREE phase.>> What is the outcome if information unit transfers are not enabled?

**That is not possible because there is no way to negotiate QAS without IU transfers enabled. Look in the PPR message and you will see this.**

**SPI-3: 296.82) Note 2; Label: Gene Milligan; Date: 10/26/99 8:42:02 PM**

82) Regarding <<An initiator that supports QAS shall negotiate the use of the QAS phase with each target that has indicated support of QAS any time the data transfer agreement is in an indeterminate state,>> What is a data transfer indeterminate state?

**Accept: The definition of what an indeterminate state is defined in the PPR message section so I added a cross-reference to that section.**

**SPI-3: 297.83) Page 123**

Note 1; Label: Gene Milligan; Date: 10/26/99 8:51:01 PM

83) The QAS list construction violates what I judged to be the conventions used in SCSI for ordered lists. But this will be dependent upon the response to the earlier comment. If this list is not in violation, then others are.

**Accept: The lists that are ordered have 1,2,3. The lists that are not ordered have a,b,c, or A,B,C. The editor believes the 1,2,3s and a,b,c's are now correct.**

**SPI-3: 298.84) Page 124**

Note 1; Label: Gene Milligan; Date: 10/26/99 9:02:40 PM

84) Regarding <<10.3.1.1.2 Information unit transfers enabled

If information unit transfers are enabled for the connecting initiator the target shall proceed to a MESSAGE OUT phase.>> Enabled by what?

**Accept: Added cross-references to the PPR message which describes how things are enabled and disabled.**

**SPI-3: 299.85) Page 125**

Note 1; Label: Gene Milligan; Date: 10/26/99 9:12:28 PM

85) In 10.3.1.2.1 change <<In this case, the initiator shall create an attention condition and on the corresponding MESSAGE OUT phase and shall issue an ABORT TASK message.>> to "In this case, the initiator shall create an attention condition and on the corresponding MESSAGE OUT phase shall issue an ABORT TASK message."

**Accept**

**SPI-3: 300.86) Page 126**

Note 1; Label: Gene Milligan; Date: 10/26/99 9:19:25 PM

86) Regarding <<The winning SCSI device shall also set the DATA BUS to a value that is the logical OR of its SCSI ID bit and the initiator's SCSI ID bit and the appropriate parity bit(s) (i.e., DB(P\_CRCA), and/or DB(P1)).>> several places, I can not think of an instance where it could be "and DB(P1)" but can think of cases where it would be "or" or "neither".

**Accept: Changed and/or to or.**

**SPI-3: 301.87) Note 2; Label: Gene Milligan; Date: 10/26/99 9:23:14 PM**

87) Change <<The initiator shall not respond to a physical reconnection if bad parity is detected (see 11.1). Also, if more than or less two SCSI ID bits are on the DATA BUS, the initiator shall not respond to a physical reconnection.>> to "The initiator shall not respond to a physical reconnection if bad parity is detected (see 11.1). Also, if more than or less than two SCSI ID bits are on the DATA BUS, the initiator shall not respond to a physical reconnection."

**Accept**

**SPI-3: 302.88) Page 127**

Note 1; Label: Gene Milligan; Date: 10/26/99 9:37:01 PM

88) In 10.5 change <<The actual content of the information is beyond the scope of this section.>> to "The actual content of the information is beyond the scope of this subclause."

**Accept**

**SPI-3: 303.89) Page 130**

Note 1; Label: Gene Milligan; Date: 10/26/99 9:58:13 PM

89) In 10.5.2.2.1.1 <<1) Shall after detecting a REQ transition;>> shall what? Everything that follows also has a shall.

**Accept: See comment SPI-3: 210.41).**

**SPI-3: 304.90) Page 131**



Note 1; Label: Gene Milligan; Date: 10/27/99 10:23:32 AM

90) Change <<10.5.2.2.1.2 DT DATA OUT phase information unit transfer exception condition handling

The target shall only respond to a iuCRC error after all the data in an information unit has been received.>> to

"10.5.2.2.1.2 DT DATA OUT phase information unit transfer exception condition handling

The target shall only respond to an iuCRC error after all the data in an information unit has been received."

Also change <<If the target is receiving a SPI L\_Q information unit and the target detects a iuCRC error (i.e., the nexus identification fails) the target shall cause an unexpected bus free by generating a BUS FREE phase (see 10.1.1).>> to "If the target is receiving a SPI L\_Q information unit and the target detects an iuCRC error (i.e., the nexus identification fails) the target shall cause an unexpected bus free by generating a BUS FREE phase (see 10.1.1)."

**Accept**

**SPI-3: 305.91) Note 2; Label: Gene Milligan; Date: 10/27/99 10:36:47 AM**

91) Regarding <<10.5.2.2.2 Data Group data field transfer>> and wherever this style of describing data transfer is used, I question if using a minimum of transmit setup and transmit hold time is a good way to describe the mechanism. If a designer actually transferred with this timing zero SCSI device skew would be required. The transfer time should be targeted at the ideal setup time (half of the ideal bit time). Perhaps this could be described as half of the negotiated bit period or half of the transfer period.

**Reject - Because there is already a statement that states these timing requirements shall not be used.**

**SPI-3: 306.92) Page 135**

Note 1; Label: Gene Milligan; Date: 10/27/99 10:49:44 AM

92) I think in <<10.5.2.3 Wide data transfer>> parity should be described for DB(7-0) not just DB(15-8).

**Accept: Added the P\_CRCA into the 8-bit description. But placed nothing into the 16-bit description.**

**SPI-3: 307.93) Page 137**

Note 1; Label: Gene Milligan; Date: 10/27/99 11:00:11 AM

93) Regarding 10.9.2 what does qualifies mean in <<A QAS-capable initiator qualifies the assertion of ACK for a minimum 50ns period to ensures the data valid time.>>?

**This comment has been overcome by events. The new wording is:**

**A QAS-capable initiator shall wait a minimum of one QAS non-DATA phase REQ (ACK) period to assert ACK after detecting the assertion of REQ.**

**A QAS-capable initiator shall assert ACK for a minimum of one QAS non-DATA phase REQ (ACK) period and shall keep the message data valid until the negation of ACK.**

**SPI-3: 308.94) Note 2; Label: Gene Milligan; Date: 10/27/99 11:01:19 AM**

94) Change <<it shall indicate that it does not wish to retry by changing>> to "it shall indicate that it will not retry by changing".

**Accept**

**SPI-3: 309.95) Page 138**

Note 1; Label: Gene Milligan; Date: 10/27/99 11:05:43 AM

95) Change <<10.9.2.1 MESSAGE OUT phase exception condition handling

If the target detects one or more parity error(s) on the message byte(s) received, it may indicate its desire to retry the message(s) by>> to

"10.9.2.1 MESSAGE OUT phase exception condition handling

If the target detects one or more parity error(s) on the message byte(s) received, it may request a retry of the message(s) by".

**Accept**

**SPI-3: 310.96) Page 141**

Note 1; Label: Gene Milligan; Date: 10/27/99 11:16:17 AM

96) In 11.2.4 change <<For a 32-byte transfer of an incrementing pattern from 00h to 1Fh: 7E8Ah, 9126h.>> to "For a 32-byte transfer of an incrementing pattern from 00h to 1Fh the CRC transferred across the SCSI bus is: 7E8Ah, 9126h."

**Accept**

**SPI-3: 311.97) Page 142**

Note 1; Label: Gene Milligan; Date: 10/27/99 11:18:37 AM

97) In 12.1 change <<the ATN signal at least two system deskew delays before asserting the targets ID in the bus.>> to "the ATN signal at least two system deskew delays before asserting the targets ID on the bus."

**Accept**

**SPI-3: 312.98) Page 143**

Note 1; Label: Gene Milligan; Date: 10/27/99 11:25:39 AM

98) Clarify <<The initiator should only create an attention condition during a RESELECTION phase to transmit an ABORT TASK SET, ABORT TASK, TARGET RESET, CLEAR TASK SET, DISCONNECT, LOGICAL UNIT RESET, or NO OPERATION message.>> by changing it to "During a RESELECTION phase the initiator should only create an attention condition to transmit an ABORT TASK SET, ABORT TASK, TARGET RESET, CLEAR TASK SET, DISCONNECT, LOGICAL UNIT RESET, or NO OPERATION message."

**Accept**

**SPI-3: 313.99) Note 2; Label: Gene Milligan; Date: 10/27/99 11:30:16 AM**

99) In 12.2 delete immediately.

**Accept**

**SPI-3: 314.100) Note 3; Label: Gene Milligan; Date: 10/27/99 11:29:15 AM**

100) Change <<The initiator may negate the ATN signal at any time except it shall not negate the ATN signal while the ACK signal is asserted during a MESSAGE OUT phase.>> to "Unless otherwise specified, the initiator may negate the ATN signal at any time, that does not violate the specified setup and hold times, except it shall not negate the ATN signal while the ACK signal is asserted during a MESSAGE OUT phase."

I think there are several other places where it is otherwise specified - conflicting(?).

**Possibly but no change has been made. (GOP- needs discussion)**

**SPI-3: 315.101) Page 144**

Note 1; Label: Gene Milligan; Date: 10/27/99 11:36:36 AM

101) I think <<Any SCSI device that detects a transceiver mode change shall:>> should be changed to "Any SCSI device that detects a reset event shall:"

and;

<<In addition any target that detects a transceiver mode change shall switch to a BUS FREE phase.>> should be changed to "In addition any target that detects a reset event shall switch to a BUS FREE phase."

**Reject: This section in which these descriptions occur is specifically defining the transceiver mode change reset event not the general case reset event.**

**SPI-3: 316.102) Page 149**

Note 1; Label: Gene Milligan; Date: 10/27/99 11:53:07 AM

102) In the next to last paragraph of 14 replace <<'>> with " two places.

**Accept**

**SPI-3: 317.103) Page 156**

Note 1; Label: Gene Milligan; Date: 10/27/99 12:04:39 PM

103) Below table 38 add an explanation of why <<The write data bit (WRDATA) and read data bit (RDDATA) shall be ignored.>> are not reserved.

**Accept - Added a note that states these bits are used by a different protocol.**

**SPI-3: 318.104) Page 161**

Note 1; Label: Gene Milligan; Date: 10/27/99 12:20:22 PM

104) Below table 43 change <<The PACKETIZED FAILURES LIST LENGTH field shall only contain a length of 4.>> to "The PACKETIZED FAILURES LIST LENGTH field shall contain a length of 4."

**Accept**

### **SPI-3: 319.105) Page 164**

Note 1; Label: Gene Milligan; Date: 10/27/99 12:44:46 PM

105) Clause 16.1.1 discusses messages with information units disabled but not enabled. A reference should be give to the specification of messages with information units enabled.

**Accept: The following was added:**

**If information unit transfers are enabled the target enters a DT DATA phase after the RESELECTION phase as described in figure 54.**

### **SPI-3: 320.106) Page 173**

Note 1; Label: Gene Milligan; Date: 10/27/99 12:54:33 PM

106) In table 55 the space ahead of ns is missing in all cases. Check globally. For 09h change <<12.5>> to "12,5". In note 6 change<< 1020>> to "1 020"

**Accept**

### **SPI-3: 321.107) Note 2; Label: Gene Milligan; Date: 10/27/99 12:58:44 PM**

107) What is the meaning of both SCSI devices in <<The transfer width that is established applies to all logical units on both SCSI devices.>>?

**Accept: That can from WDTR. But it is not right there either. The 'to all logical unit' has been removed from PPR and WDTR.**

### **SPI-3: 322.108) Page 174**

Note 1; Label: Gene Milligan; Date: 10/27/99 1:01:51 PM

108) Change <<The responding SCSI device uses the protocol options bits to indicate the protocol options requested by the originating SCSI device the responding SCSI device has enabled.>> to "The responding SCSI device uses the protocol options bits to indicate the protocol options, requested by the originating SCSI device, that the responding SCSI device has enabled."

**Accept - Change not supported to disabled and supported to enabled.**

### **SPI-3: 323.109) Note 2; Label: Gene Milligan; Date: 10/27/99 1:11:00 PM**

109) Change <<(i.e., data group transfers shall be enabled)>> to "(e.g., data group transfers shall be enabled)" since ST may be the result of the negotiation.

Also change <<information unit transfers are supported when received from the responding>> to "information unit transfers are enabled when received from the responding"

**Accept - Change not supported to disabled and supported to enabled.**

**SPI-3: 324.110) Note 3; Label: Gene Milligan; Date: 10/27/99 1:18:53 PM**

110) My prior change request depends upon this comment. If the originating SCSI device sends a DT enable request bit (DT\_REQ) of zero indicates that DT DATA phases are to be disabled to another SCSI device that supports DT DATA phases should the receiving device respond with a (DT\_REQ of one indication that DT DATA phases are supported or a (DT\_REQ of zero indicating that DT DATA phases are disabled? I prefer the latter. But the text indicates the former. This question applies to each of the bits.

**Accept - Change not supported to disabled and supported to enabled.**

**SPI-3: 325.111) Note 4; Label: Gene Milligan; Date: 10/27/99 1:43:04 PM**

111) Change <<A PARALLEL PROTOCOL REQUEST message exchange shall be initiated by a SCSI device whenever a previously arranged parallel protocol agreement may have become invalid.>> to "A PARALLEL PROTOCOL REQUEST message exchange shall be initiated by an initiator whenever a previously arranged parallel protocol agreement may have become invalid."

The present wording is equivalent to the objectionable SDTR requirement that most targets are required to violate.

**Reject: Your new wording prevents targets from initiating PPR. This could cause improper communications to occur between the SCSI devices. The fact that some poorly designed initiators cannot handle a target initiated PPR is not reason to remove it from the standard.**

**SPI-3: 326.112) Page 175**

Note 1; Label: Gene Milligan; Date: 10/27/99 1:46:37 PM

112) Regarding <<If the responding SCSI device is able to receive data successfully with these values (or smaller periods or larger REQ/ACK offsets or both), it returns the same values in its PARALLEL PROTOCOL REQUEST message.>> This is the way I prefer it but it is presently in conflict with the stated requirements.

**Which stated requirements are you referring to? (GOP - needs discussion)**

**SPI-3: 327.113) Page 176**

Note 1; Label: Gene Milligan; Date: 10/27/99 1:55:41 PM

113) Regarding table 57 what impact, if any, does asynchronous have on DT transfers. The protocol description of asynchronous transfers has a different timing requirement than DT and different than ST.

Is it likely that devices that do not support DT will support PPR? I doubt the message reject option is needed since for the case given the message probably will be rejected by the recipient.

Message reject from the respondent is elsewhere forbidden. But I presume table 57 is referring to a respondent that does not support the message.

**Accept - Changed the MESSAGE REJECT message row by adding in the following 'The originating SCSI device shall set' to the implied agreement column. Made this change to PPR, SDTR, and PPR.**

**SPI-3: 328.114) Page 177**

Note 1; Label: Gene Milligan; Date: 10/27/99 2:03:10 PM

114) Per prior comment change <<16.2.9.1 Target initiated PARALLEL PROTOCOL REQUEST negotiation

If the target recognizes that PARALLEL PROTOCOL REQUEST negotiation is required, it sends a PARALLEL PROTOCOL REQUEST message to the initiator.>> to

"16.2.9.1 Target initiated PARALLEL PROTOCOL REQUEST negotiation

If the target recognizes that PARALLEL PROTOCOL REQUEST negotiation is required, it may send a PARALLEL PROTOCOL REQUEST message to the initiator." Or alternatively limit the initiation to initiators and delete this subclause.

**Reject: Your new wording allows targets to not initiate PPR. This could cause improper communications to occur between the SCSI devices. The fact that some poorly designed initiators cannot handle a target initiated PPR is not reason to remove it from the standard.**

### **SPI-3: 329.115) Page 178**

Note 1; Label: Gene Milligan; Date: 10/27/99 2:06:56 PM

115) Just before 16.2.10 in <<both SCSI devices shall use the go to eight-bit/asynchronous data transfer mode>> delete "go to".

**Accept**

### **SPI-3: 330.116) Note 2; Label: Gene Milligan; Date: 10/27/99 2:11:16 PM**

116) In 16.2.11 change <<When information unit transfers are enabled there is an implied restore pointers. For more information on this see 14 and 14.2.3.>> to "When information unit transfers are enabled there are implied restore pointers as specified in 14 and 14.2.3." But 14 includes 14.2.3 so why not just refer to 14? Could there be a hanging paragraph?

**Accept: Changed 14 to 14.1 and yes it was a hanging paragraph!!**

### **SPI-3: 331.117) Page 179**

Note 1; Label: Gene Milligan; Date: 10/27/99 2:13:16 PM

117) Apply earlier comment on the format of numbers to table 59.

**Accept**

### **SPI-3: 332.118) Page 180**

Note 1; Label: Gene Milligan; Date: 10/27/99 2:17:40 PM

118) Where is the agreed to backoff between PPR and SDTR if a non-standard expander spoils the negotiation? Well actually it is in an informative annex. Should it be in the body of the standard?

**The current way it is specified was the way to was agreed to be changed to. No change.**

### **SPI-3: 333.119) Page 194**

Note 1; Label: Gene Milligan; Date: 10/27/99 2:27:49 PM

119) In 18.1.1 change <<1024>> to "1 024".

**Accept**

### **SPI-3: 334.120) Page 202**

Note 1; Label: Gene Milligan; Date: 10/27/99 2:34:48 PM

120) Table A.1 references Annex G. It seems inappropriate for LVD requirements to reference a single ended annex especially since it was stated in T10 meetings the annex was to be replaced by new material developed for SPI-3.

**Accept - Remove the 'see annex G for calculations' statement in note 2. Reference table 10 instead.**

### **SPI-3: 335.121) Page 203**

Note 1; Label: Gene Milligan; Date: 10/27/99 2:43:27 PM

121) Regarding <<A.2.1 Differential output voltage, V S

This subclause does not specify requirements for drivers with source impedances less than 1000 ohms.>> are drivers with source impedance less than (change above error) 1 000 (change above error) Ohms (requested global change) non-standard without requirements or is SPI-3 incomplete pending the requirements?

<<Figure A.2 shall only apply to drivers with source impedances greater than 1000 ohms.>> Why is Figure A.2 singled out? Per the above Table A.2 and Figure A.1 also do not apply.

**Accept - This clause only applies to devices that have impedances GT 1000. Deleted the following sentence 'Figure A.2 shall only apply to drivers with source impedances greater than 1000 ohms.'**

### **SPI-3: 336.122) Page 207**

Note 1; Label: Gene Milligan; Date: 10/27/99 2:47:25 PM

122) Why does A.2.4 use "its common" when apparently referring to ground?

**Possibly but no change has been made. (GOP- needs discussion)**

### **SPI-3: 337.123) Page 208**

Note 1; Label: Gene Milligan; Date: 10/27/99 2:50:18 PM

123) In A.2.5 change <<The slew rates specified above are requirements>> to "The rise and fall times specified above are requirements"

**Accept**

### **SPI-3: 338.124) Page 214**

Note 1; Label: Gene Milligan; Date: 10/27/99 3:17:17 PM

124) At the moment B.1 requires that a higher priority device that has not won arbitration ever must wait for lower priority devices, that have previously lost arbitration, to win arbitration before arbitrating for the first

time. Why?

**This entire annex has been replaced See comment SPI-3: 29.25)**

**SPI-3: 339.125)**

125) Change the numbers in annex B to match the convention for decimal numbers.

**This entire annex has been replaced See comment SPI-3: 29.25)**

**SPI-3: 340.126) Note 2; Label: Gene Milligan; Date: 10/27/99 3:19:52 PM**

126) Note 38 contradicts the normative requirement above it. Change one or the other to agree.

**This entire annex has been replaced See comment SPI-3: 29.25)**

**SPI-3: 341.127) Page 215**

Note 1; Label: Gene Milligan; Date: 10/27/99 3:23:08 PM

127) Note 39 repeats text presented earlier in Annex B. Delete it. Consider reorganizing the annex to remove the temptation to repeat text.

**This entire annex has been replaced See comment SPI-3: 29.25)**

**SPI-3: 342.128) Note 2; Label: Gene Milligan; Date: 10/27/99 3:26:19 PM**

128) Regarding (4B) <<except when the winning device is an initiator and does not select another device after winning arbitration.>> Why would an initiator do that?

**This entire annex has been replaced See comment SPI-3: 29.25)**

**SPI-3: 343.129) Page 216**

Note 1; Label: Gene Milligan; Date: 10/27/99 3:36:57 PM

129) In B.4 change <<This would require a second register in which a bit is enabled for each lower priority SCSI device to which a higher priority SCSI device shall be fair.>> to "An example method would be to have a second register with a bit enabled for each lower priority SCSI device that a higher priority SCSI device will be fair to. Multiple initiators should have a means to be cooperative. The means for cooperation is beyond the scope of this standard.

**This entire annex has been replaced See comment SPI-3: 29.25)**

**SPI-3: 344.130) Page 217**

Note 1; Label: Gene Milligan; Date: 10/27/99 3:38:58 PM

130) Why include <<NOTE 45 - The details of the actual SCSI device supply requirements need to be studied for each SCSI device and enclosure combination.>>?

**Possibly but no change has been made. (GOP- needs discussion)**



**SPI-3: 345.131) Page 218**

Note 1; Label: Gene Milligan; Date: 10/27/99 3:45:27 PM

131) Regarding C.1.2 <<Three charge signals, one for each of the power supply voltages, provide controlled precharging of the disk SCSI device's internal circuits to avoid excessive surge currents during hot plugging.>> SCA connectors are not limited to disk drives. Delete disk.

**Accept**

**SPI-3: 346.132) Note 2; Label: Gene Milligan; Date: 10/27/99 3:49:30 PM**

132) Regarding <<NOTE 46 - Industry practice presently requires that SCSI devices interconnected for synchronization be the same or equivalent models.>> Actually industry practice is that spindle synchronization is obsolete. Consider obsoleting this clause.

**Accept: Removed the note but not the clause. Although if someone was to make a motion to able the spindle sync line obsolete I would not object!**

**SPI-3: 347.133) Page 219**

Note 1; Label: Gene Milligan; Date: 10/27/99 3:51:51 PM

133) What should be in the first row of the Output voltage column of table C.3?

**Don't know, no change has been made. (GOP- needs discussion)**

**SPI-3: 348.134) Page 221**

Note 1; Label: Gene Milligan; Date: 10/27/99 3:55:31 PM

134) Correct the note in table C.6 to use SPI-3 terminology in lieu of 16 bit option.

**Accept; changed to 'wide data transfers'**

**SPI-3: 349.135) Page 222**

Note 1; Label: Gene Milligan; Date: 10/27/99 3:58:33 PM

135) In C.1.7.3 change <<The following SCSI device behaviors are defined when a SCSI device detects to open level of MATED 1:>> to "The following SCSI device behaviors are defined when a SCSI device detects the open level of MATED 1:"

**Accept**

**SPI-3: 350.136) Page 231**

Note 1; Label: Gene Milligan; Date: 10/27/99 4:14:48 PM

136) Regarding E.2.1.3 what is <<mp>>?

**Accept - This should be ρ (mp)**

**SPI-3: 351.137) Page 236**

Note 1; Label: Gene Milligan; Date: 10/27/99 4:29:28 PM

137) Regarding E.2.3.3 what is an <<S11 measurement>> and where is it defined? Same question later regarding S12.

**Don't know, no change has been made. (GOP- needs discussion)**

### **SPI-3: 352.138) Page 237**

Note 1; Label: Gene Milligan; Date: 10/27/99 4:32:25 PM

138) Regarding E.3.1.1 add a space in <<0,5cm>> one place.

**Accept**

### **SPI-3: 353.139) Page 239**

Note 1; Label: Gene Milligan; Date: 10/27/99 4:35:37 PM

139) Regarding E.3.3 what does <<Selection of this test method is on underway.>> mean? Either delete the clause or correct the clause and add the standard statement for contacting T10 to get the needed information.

**Accept; section deleted**

### **SPI-3: 354.140) Page 242**

Note 1; Label: Gene Milligan; Date: 10/27/99 4:41:54 PM

140) In E.7.1 I think input and output are not used in the same sense as in the rest of the standard where input would be found at the receiving SCSI device and the output at the transmitting SCSI device. I think a definition should be added.

**Don't know, no change has been made. (GOP- needs discussion)**

### **SPI-3: 355.141) Note 2; Label: Gene Milligan; Date: 10/27/99 4:43:56 PM**

141) Figure E.7 contradicts the statement introducing it.

**Don't know, no change has been made. (GOP- needs discussion)**

### **SPI-3: 356.142) Page 243**

Note 1; Label: Gene Milligan; Date: 10/27/99 4:46:55 PM

142) On page 243 of 292 (pdf) there is a term used in the formula that is not explained near the equation.

**Don't know, no change has been made. (GOP- needs discussion)**

### **SPI-3: 357.143) Note 2; Label: Gene Milligan; Date: 10/27/99 4:48:31 PM**

143) Annex E has musts that should be changed to shall. Suggest a global search.

**Accept**

**SPI-3: 358.144) Page 244**

Note 1; Label: Gene Milligan; Date: 10/27/99 4:53:12 PM

144) E.7.1.2 uses minus db for attenuation although the annex explains this should not be done. (But see comment 146.)

Also the numbers need to conform to the conventions.

**Accepted; You are correct those symbols are approximate. I have changed them to the word 'approximately'.**

**SPI-3: 359.145) Page 247**

Note 1; Label: Gene Milligan; Date: 10/27/99 4:58:59 PM

145) E.7.1.3 needs the escape clause "or equivalent" several places.

**Not clear where this would go, no change has been made. (GOP- needs discussion)**

**SPI-3: 360.146) Page 249**

Note 1; Label: Gene Milligan; Date: 10/27/99 5:02:51 PM

146) In E.7.1.5 change <<The instrument automatically accounts for the attenuation found in the calibration scan.>> to "The instrument should automatically account for the attenuation found in the calibration scan."

Judging by this clause the earlier minus db may have been an approximate db but it is hard to tell.

**Accepted; You are correct those symbols are approximate. I have changed them to the word 'approximately'.**

**SPI-3: 361.147) Page 251**

Note 1; Label: Gene Milligan; Date: 10/27/99 5:12:58 PM

147) Regarding E.8 <<This test is limited to a the single applied pulse method.>> choose between "a" and "the".

**Accept**

<<The sum of the noise from the aggressor pairs on the victim pair IS the cross talk.>> Define the acronym or make it lower case.

<<This requirement may appear contrary to logic that says the maximum disturbance occurs with the maximum signal swing and that occurs with a peak to peak measurement.>> Delete "and".

**Accept**

**SPI-3: 362.148) Page 252**

Note 1; Label: Gene Milligan; Date: 10/27/99 5:16:10 PM

148) In E.8.2 what is <<SMI1>>?

**Don't know, no change has been made. (GOP- needs discussion)**

### **SPI-3: 363.149) Page 259**

Note 1; Label: Gene Milligan; Date: 10/27/99 5:22:04 PM

149) During the SPI-3 review meetings I asked if we were going to review Annex G. The T10 Vice-Chairman responded that we did not need to review it since Annex G would be replaced by the annexes being developed by the cable working group. I agreed with that conclusion. Delete Annex G. Alternatively upgrade it to be Transmission line considerations for data transfer rates up to fast-80.

**There was a miscommunication here in that an annex was removed but it was not the one referred to here. Annex G was not to be removed. It only applies to SE devices so does not need to be updated for fast-40 or fast-80 as those only apply to differential buses. I have added SE into the title to help remove this confusion.**

### **SPI-3: 364.150) Page 265**

Note 1; Label: Gene Milligan; Date: 10/27/99 5:29:15 PM

150) Regarding J1.1 <<permittivity.>> should be added to the glossary. Or alternatively replace it with dielectric constant.

**Accept**

### **SPI-3: 365.151) Page 269**

Note 1; Label: Gene Milligan; Date: 10/27/99 5:33:12 PM

151) Regarding J.1.6 what is <<odd mode>>?

**Don't know, no change has been made. (GOP- needs discussion)**

### **SPI-3: 366.152) Page 271**

Note 1; Label: Gene Milligan; Date: 10/27/99 5:37:59 PM

152) Under figure J.8 change <<Controlled impedance boards in which all the impedance's match within>> to "Controlled impedance boards with the impedances matching within".

**Accept**

### **SPI-3: 367.153) Page 273**

Note 1; Label: Gene Milligan; Date: 10/27/99 5:44:04 PM

153) Annex J also needs to have the numbers with a space before the units in some places.

**Accept**

### **SPI-3: 368.154) Note 2; Label: Gene Milligan; Date: 10/27/99 5:45:26 PM**

154) On page 273 of 292 (pdf) delete <<your>>

**Accept**

**SPI-3: 369.155) Page 276**

Note 1; Label: Gene Milligan; Date: 10/27/99 5:53:54 PM

155) On page 276 of 292 check to see if Tpd or T'pd should be used. Also delete <<, remember that>>.

**Accept; T'pd is correct as currently in the standard.**

**SPI-3: 370.156) Page 277**

Note 1; Label: Gene Milligan; Date: 10/27/99 5:58:20 PM

156) On page 277 of 292 (pdf) change <<The signals magnitude>> to "The signal's magnitude".

**Accept**

**SPI-3: 371.157) Page 284**

Note 1; Label: Gene Milligan; Date: 10/27/99 6:16:11 PM

157) Regarding Table M.1 change <<2 For calculation purposes these signals are zero. However, these virtual signals could be used for other functions in a future standard.>> to "2 For calculation purposes these signals are zero. However, these virtual signals may be used for other functions in a future standard."

**Accept**

**SPI-3: 372.158) Page 286**

Note 1; Label: Gene Milligan; Date: 10/27/99 6:30:05 PM

158) In M.3.2 change <<possible times when a SCSI device could try to enable protection code>> to "potential times when a SCSI device may try to enable protection code". Make the change from possible to potential and could to may global.

**Accept**

**SPI-3: 373.159)**

159) Regarding global searches there presently are:

2 musts all in Annex E

32 desires or desired that can be replaced with a deletion, required, needs, or needed.

24 immediate or immediately that can be replaced usually by a deletion and perhaps in some cases by a next wording.

17 cans or cannots that may be replaced by a deletion with a change to the form of the following word or by a may.

**Accept**

**SPI-3: 374.160)**

160) Regarding table A.5, does the 3,6 volts conflict with the requirements in clause 7? See for example Table 17 and the 3,01 V limit.

**Accept: Added 'differential' to column one of table A.5 header.**

**Comments from Paul D. Aloisi of Unitrode Corporation:**

**SPI-3: 375.1)**

The cable information in section 6 needs to be updated to 99-111r7 and the annex e to the latest version of 98-219.

**See comments 33.1 though 96.64.**