

TO: X3T10 Membership

X3T10/94-061r2

FR: L. Lamers

RE: Fast-20 SCSI Parallel Interface Proposal

DT: March 31, 1994

1 Connecting devices

1.1 Connecting devices with single-ended transceivers

The maximum cumulative length of the signal path from terminator to terminator when using single-ended transceivers shall be 1 meters. The signal path shall be a controlled impedance environment.

The stub length shall not exceed 0,1 meter. The stub length is measured from the transceiver to the connection to the mainline SCSI bus. The spacing of devices on the mainline SCSI bus shall be at least three times the stub length to avoid stub clustering.

1.2 Connecting devices with differential transceivers

Twisted-pair cable (either twisted-flat or discrete wire twisted pairs) should be used with differential transceivers.

The maximum cumulative cable length shall be 25 meters.

The stub length shall not exceed 0,2 meter. The stub length is measured from the transceiver to the connection to the mainline SCSI bus. The spacing of devices on the mainline SCSI bus shall be at least three times the stub length to avoid stub clustering.

2 SCSI parallel interface electrical characteristics

The SPI-2 parallel interface can use one of two transceiver alternatives:

- a) single-ended drivers and receivers, in which one conductor of the each signal pair is active and one is grounded;
- b) differential drivers and receivers, in which both conductors of each signal pair are active.

The single-ended and differential alternatives are mutually exclusive.

SCSI devices shall not include termination.

2.1 Single-ended alternative

2.1.1 Single-ended termination

All SCSI bus signals are common among all devices connected to the bus. All signal lines shall be terminated at both ends with a terminator that is compatible with the type of transceivers used in the SCSI devices. The termination points define the ends of the bus. These termination points may be internal to an SCSI device.

All single-ended signals not defined as RESERVED, GROUND, or TERMPWR shall be terminated exactly once at each end of the bus. The termination of each signal shall meet these requirements:

- the terminators shall be powered by the TERMPWR line.
- each terminator shall source current to the signal line whenever its terminal voltage is below 2,5 V d.c. and this current shall not exceed 24 Ma for any line voltage above 0,2 V d.c.;
- the voltage on all released signal lines shall be at least 2,5 V d.c.;
- these conditions shall be met with any legal configuration of targets and initiators as long as at least one device is supplying TERMPWR;
- the terminator at each end of the SCSI bus (see clause 6) shall add a maximum of 25 Pf capacitance to each signal.

2.1.2 Single-ended output characteristics

Single-ended signals shall use active-negation drivers. Active-negation drivers have three states: asserted, negated, and high-impedance. Each signal sourced by an SCSI device shall have the following output characteristics when measured at the SCSI device's connector:

- V_{OL} (low-level output voltage) = 0,0 to 0,5 V d.c. at $I_{OL} = 48$ mA (signal asserted);
- V_{OH} (high-level output voltage) = 2,5 to 5,25 V d.c. (signal negated).
- V_{OH} (high-level output voltage) = 2,0 to 3,24 V d.c. at $I_{OH} = 7$ mA (signal negated);
- V_{OH} (high-level output voltage) < 3,0 V d.c. at $I_{OH} = 20$ mA (signal negated).

NOTE: In words, these expressions mean: If the driver is negated and loaded at 7 mA, then the output voltage is between 2,0 and 3,24 V d.c. If the current is 20 mA, the voltage is less than 3,0 V d.c.

All single-ended drivers shall maintain the high-impedance state during power-on and power-off cycles.

SCSI devices should meet the following specifications for all signals when measured on the test circuit shown in figure 1:

- t_{rise} (rise time) = 600 mV per ns maximum (0.7 V d.c. to 2.3 V d.c.);
- t_{fall} (fall time) = 600 mV per ns maximum (2.3 V d.c. to 0.7 V d.c.).

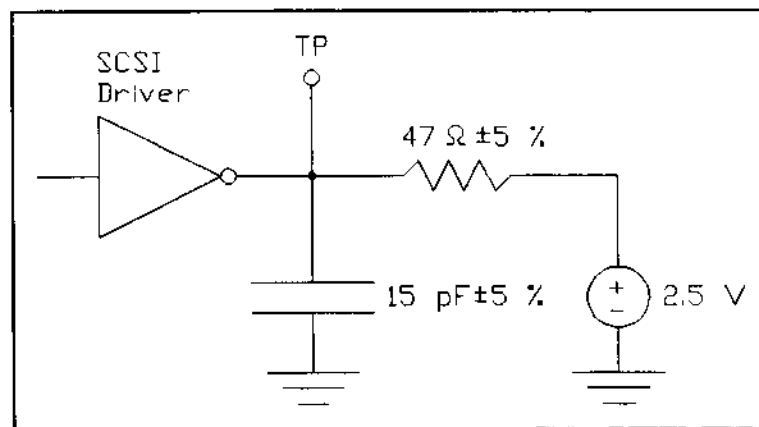

Figure 1 - Rise time test circuit

2.1.3 Single-ended Input characteristics

SCSI devices with power-on shall meet the following electrical characteristics on each signal (including both receivers and disabled drivers):

- a) V_{IL} (Low-level input voltage) = 0,0 to 0,8 V d.c. (signal true);
- b) V_{IH} (High-level input voltage) = 2,0 to 5,25 V d.c. (signal false);
- c) I_{IL} (Low-level input current) = +/- 20 uA at $V_I = 0,5$ V d.c.;
- d) I_{IH} (High-level input current) = +/- 20 uA at $V_I = 2,7$ V d.c.;
- e) Minimum input hysteresis = 0,4 V d.c.

The transient leakage current that may occur (e.g. with some ESD protection circuits) at the time of physical insertion of an SCSI device is an exponentially decaying current that does not exceed the following specifications:

- a) $I_{IH,HP}$ (hot-plug high-level input current peak value) = + 1.5 mA at $V_I = 2.7$ V d.c.;
- b) T_{HP} (transient current duration to 10% of peak value) = 20 us maximum.

SCSI devices with power-off should meet the above I_{IL} and I_{IH} electrical characteristics on each signal, except at time of physical insertion, when $I_{IH,HP}$ and T_{HP} prevail.

The nominal switching threshold should be 1.4 V d.c. to achieve maximum noise immunity and to assure proper operation with complex cable configurations.

2.1.4 Single-ended input and output characteristics

The single-ended signals shall have the following characteristics when measured at the SCSI device's connector:

- a) I_L (Leakage current) = -20 uA to +20 uA at $V_I = 0,0$ to 5,25 V d.c. (high-impedance state);
- b) Maximum signal capacitance = 25 pF, measured at the beginning of the stub (see annex E).

2.2 Differential alternative

2.2.1 Differential termination

All SCSI bus signals are common among all devices connected to the bus. All signal lines shall be terminated at both ends with a terminator that is compatible with the type of transceivers used in the SCSI devices. The termination points define the ends of the bus.

All differential signals consist of two lines denoted +SIGNAL and -SIGNAL. A signal is true when +SIGNAL is more positive than -SIGNAL, and a signal is false when -SIGNAL is more positive than +SIGNAL. All assigned differential signals described in 5.3 except TERMPWR, RESERVED, and GROUND shall be terminated at each end of the cable with a terminator network as shown in figure 9. Resistor tolerances in the terminator network shall be $\pm 5\%$ or less. The characteristic impedance of differential terminators is 122 ohms.

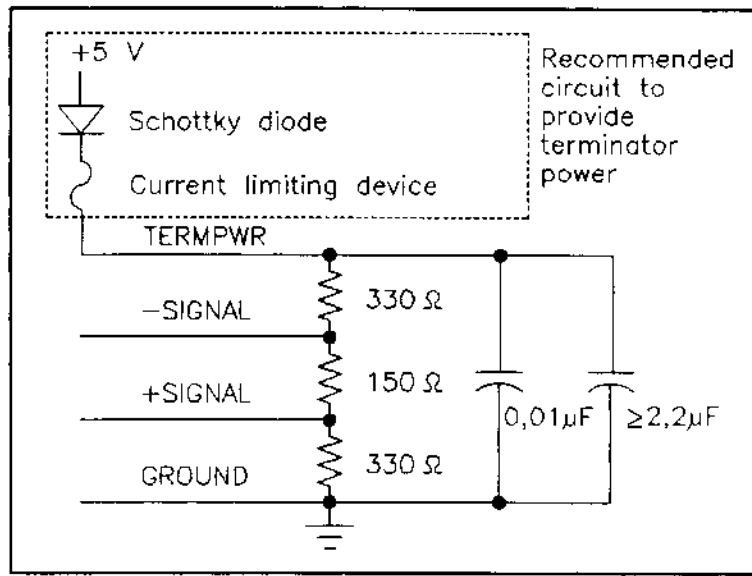

Figure 9 - Termination for differential devices

2.2.2 Differential output characteristics

Each differential signal sourced by an SCSI device shall have the following output characteristic when measured at the SCSI device's connector:

- V_{OD} (differential output voltage) = 1,0 V minimum;
- Shall conform to EIA RS-485 (ISO 8482-1982 TIA TR30.2).

All differential drivers shall maintain the high-output impedance during power-on and power-off cycles.

The test circuit for testing these characteristics is shown in figure 10.

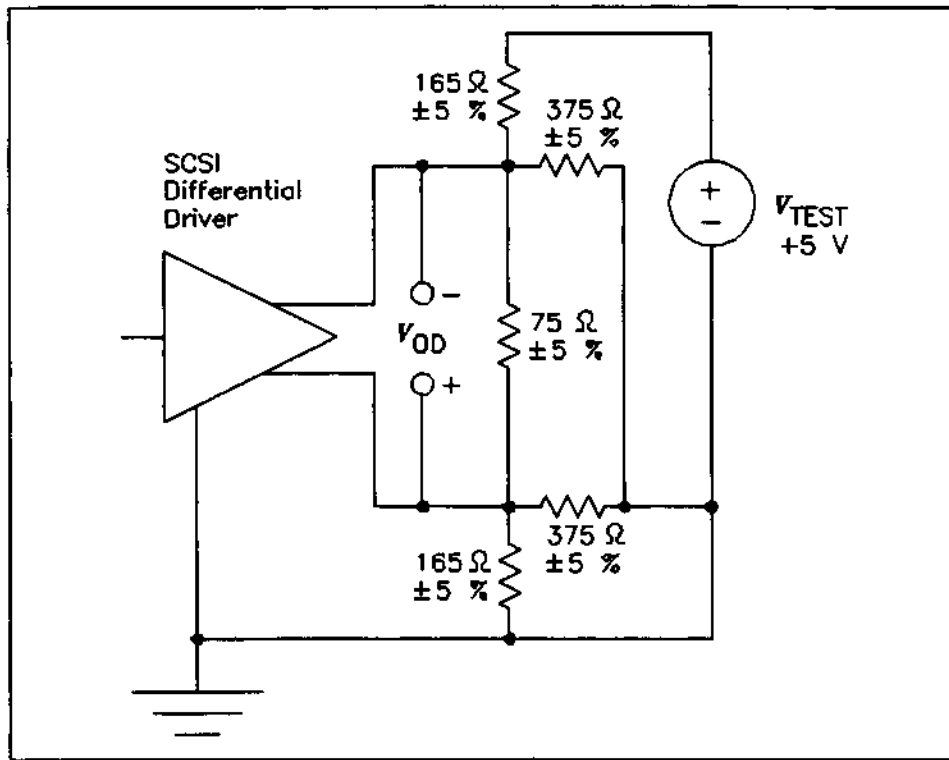

Figure 10 - Differential test circuit

2.2.3 Differential input characteristics

Each differential signal shall have the following characteristics when measured at the SCSI device's connector (including both receivers and disabled drivers):

- a) Maximum input capacitance = 25 pF;
- b) Minimum input hysteresis = 35 mv.

The input characteristics shall additionally conform to EIA RS-485 (ISO 8482-1982 TIA TR30.2).

2.2.4 Differential driver protection

The DIFFSENS signal is a single-ended signal that is used as an active high enable for the differential drivers. If a single-ended device or terminator is inadvertently connected, this signal is grounded, disabling the differential drivers (see figure 11).

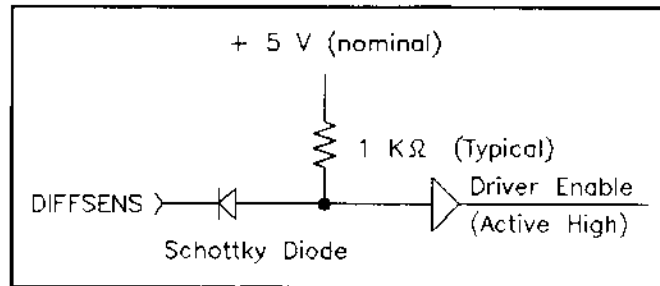

Figure 11 - Differential driver protection circuit

Table 10 - SCSI bus timing values

Timing description	Timing values			
	ultra	fast	slow	asynch
Arbitration Delay	2.4 us	2.4 us	2.4 us	2.4 us
Bus Clear Delay	800 ns	800 ns	800 ns	800 ns
Bus Free Delay	800 ns	800 ns	800 ns	800 ns
Bus Set Delay	1.8 us	1.8 us	1.8 us	1.8 us
Bus Settle Delay	400 ns	400 ns	400 ns	400 ns
Cable Skew Delay (note 1)	3 ns	4 ns	4 ns	4 ns
Data Release Delay	400 ns	400 ns	400 ns	400 ns
Receive Assertion Period	11 ns	22 ns	70 ns	n/a
Receive Hold Time (note 2)	11.5 ns	25 ns	25 ns	n/a
Receive Negation Period	11 ns	22 ns	70 ns	n/a
Receive Setup Time (note 2)	6.5 ns	15 ns	15 ns	n/a
Reset Hold Time	25 us	25 us	25 us	25 us
Selection Abort Time	200 us	200 us	200 us	200 us
Selection Time-out Delay (note 3)	250 ms	250 ms	250 ms	250 ms
System Deskew Delay	15 ns	20 ns	45 ns	45 ns
Transmit Assertion Period	15 ns	30 ns	80 ns	n/a
Transmit Hold Time (note 2)	16.5 ns	33 ns	53 ns	n/a
Transmit Negation Period	15 ns	30 ns	80 ns	n/a
Transmit Setup Time (note 2)	11.5 ns	23 ns	23 ns	n/a

Notes -

- 1) This time does not apply at the SCSI device connectors.
- 2) See Annex A for examples of how to calculate setup and hold timing.
- 3) This is a recommended time. It is not mandatory.

Annex A
(informative)

Setup and hold timing

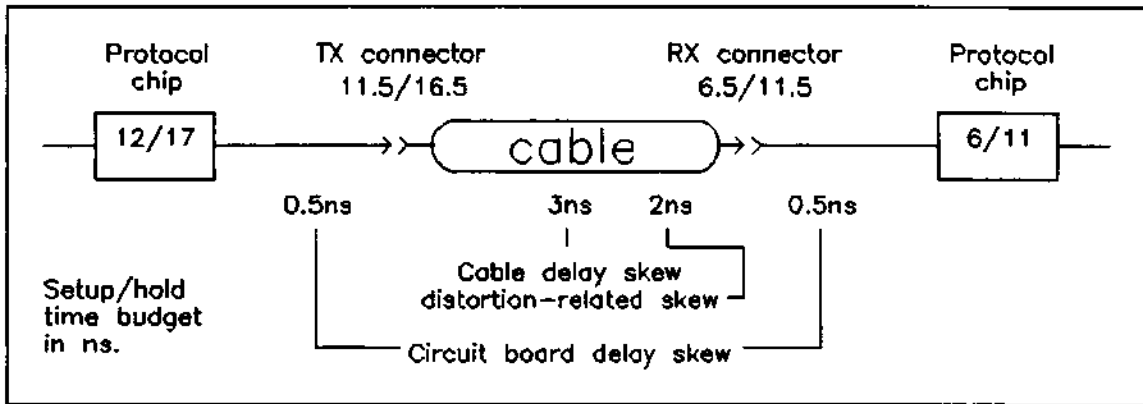

Figure A1 - Ultra setup and hold times for single-ended applications

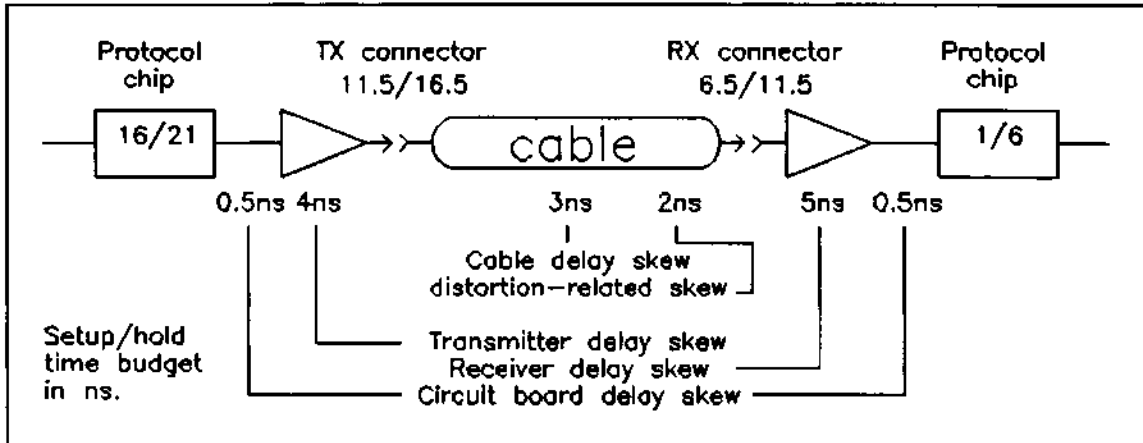

Figure A2 - Ultra setup and hold timing for differential applications

The receiver delay skew is the maximum difference in propagation delay time between any two receivers on the REQ, REQQ, ACK, ACKQ, DATA BUS or parity signals of the same bus when external receivers are used.

The transmitter delay skew is the maximum difference in propagation delay time between any two transmitters on the REQ, REQQ, ACK, ACKQ, DATA BUS or parity signals of the same bus when external transmitters are used.

In systems with external transceivers, the total skew budget is 14 ns.

Transmitter chip	16 ns setup/21 ns hold	
Foil	0.5 ns	} 15 ns
External driver	4 ns (recommended)	
----- TX connector -----		
25 meter cable	3 ns	
Distortion	2 ns	
----- RX connector -----		
External Receiver	5 ns	
Foil	0.5 ns	
Receiver chip	1 ns setup/6 ns hold	

At its connector, the transmitting SCSI device should:

- 1) drive data no less than 11.5 ns before asserting the REQ_x or ACK_x signal;
- 2) keep that data valid for no less than 16.5 ns following the assertion of the REQ_x or ACK_x signal.

The receiving device shall be able to latch the data at its connector when:

- 1) data is valid no more than 6.5 ns prior to the false-to-true transition of the REQ_x or ACK_x signal;
- 2) data is valid no more than 11.5 ns following the false-to-true transition of REQ_x or ACK_x signal.

When 4.5 ns is added to the transmit device timing for transmitter skew and skew due to foil delays, the transmitting SCSI chip setup and hold timings are 16 ns and 21 ns, respectively. Similarly, when 5.5 ns is subtracted from the skew budget of the receiving device, 1 ns and 6 ns are left for receive chip setup and hold, respectively.

In the case of ultra timing with no external transceivers over a 1 m signal path, the total skew budget is 6 ns, compared to 15 ns. The 9 ns difference is used to relax the timing at the SCSI protocol chips (4 ns for the transmitting chip, and 5 ns for the receiving chip).

NOTE: Component vendors may require that differential drivers and receivers be operated within restricted voltage and temperature differences to achieve the specified transmitter and receiver delay skew values.

Annex B
(informative)

Measurement of setup and hold timing

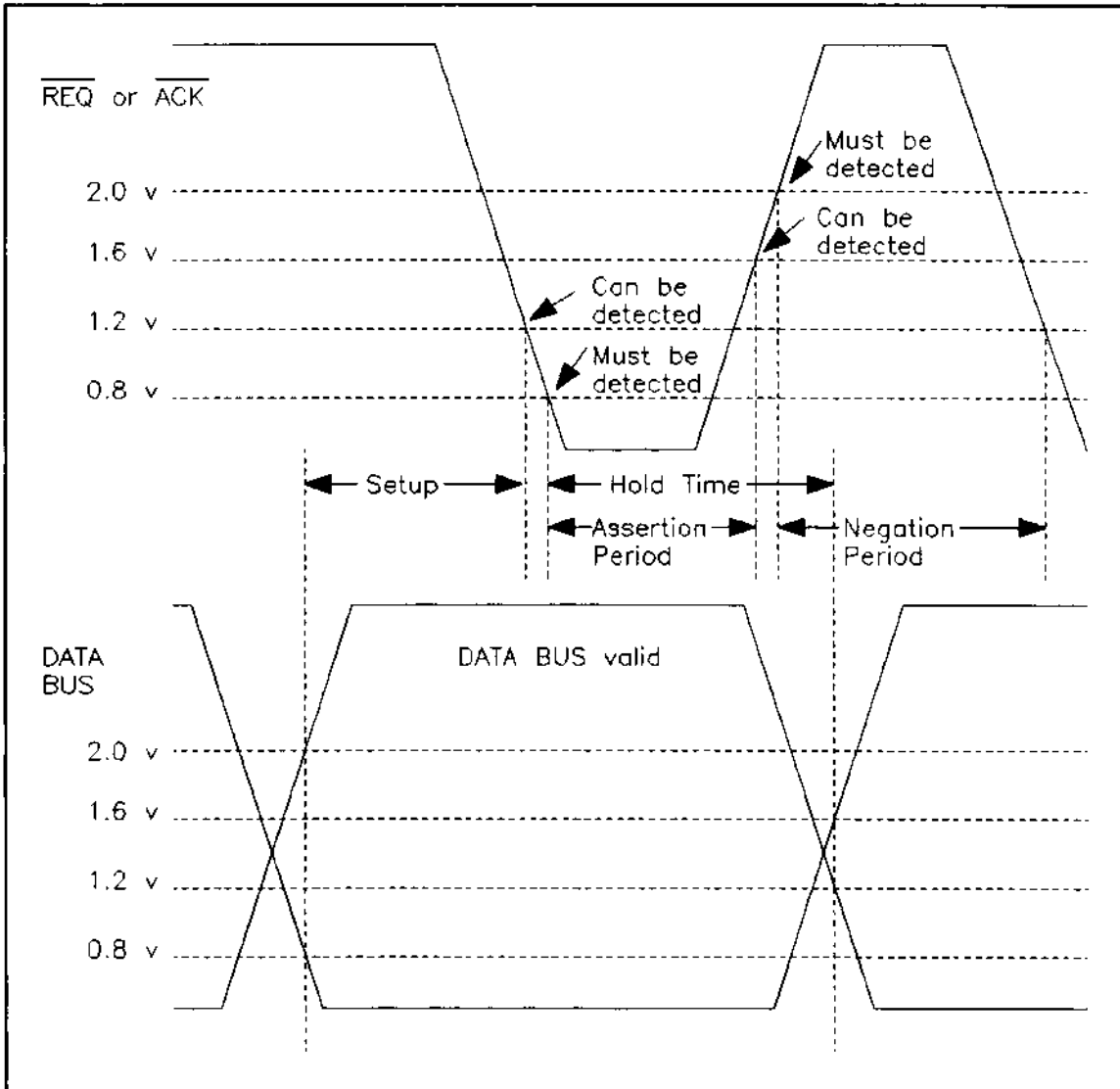

Figure B2 - Ultra Setup and hold timing for single-ended