

08-358r1

Proposal for SAS 2.1 Specification to Enable Support for Active Cables

Revision 11

Gourgen Oganessyan

QUELLAN

September 10, 2008

Introduction

Inclusion of active cable interconnect option into the SAS specification would be beneficial in that it enables active copper and optical interconnects, to support longer reaches, lighter cable, etc.

It is proposed that active cable support may be enabled in the intermediate SAS-2.1 specification by making minimum changes to the SAS-2 spec and inserting a section on power supply option.

A proposal for such changes and a starting point for the text of specification is presented.

Change Log

Changes Since 01/08/2008

- Removed the 1.2V power supply option – the proposal now has a single 3.3V supply.
- Added a section on capacitive coupling.

Changes Since 02/12/2008

- Added a sections, tables and figures for keying of active cable: prevents active cable from plugging into a passive port, while allowing passive cable to plug into an active port.

Changes Since 03/07/2008

- Fixed typos:
 - Title of Table 60: Added the word “Mini” in front of “SAS”
 - In Section **5.2.7.3.2 Power consumption** replaced “per an interface” with “per cable”; the section now reads: “The voltage and current requirements are such as to enable support for active cable assemblies with power consumption at 3.3 V of up to 2 W per cable with four functioning links.”
 - In Section **5.2.7.3.2 Power consumption** replaced “per an interface” with “per cable”; the section now reads: “The voltage and current requirements are such as to enable support for active cable assemblies with power consumption at 3.3 V of up to 2 W per cable with four functioning links.”

Changes Since 05/02/2008

- Modified Section **5.2.7.3.6 Short Circuit Protection** to read: “The active cable power supply shall have protection against the connection of the Vcc pin to ground, and shall limit short circuit current to below 25 mA when equivalent load resistance is less than 1 Ohm.”

Changes Since 05/15/2008

- Collapsed the sections **5.2.7.3.2 - 5.2.7.3.2** into a single section **5.2.7.3.2 Power Supply Requirements**, and summarized the numbers in a table (Table 61).
- Inserted the word “capacitors” in the last sentence of section **5.2.7.3.6 Bypassing**.
- Modified Section **5.2.7.3.6 Short Circuit Protection** to read: “The active cable power supply shall have protection against the connection of the Vcc pin to ground or over-current loading, and shall limit the output current when the equivalent load resistance is less than 1 Ohm”.
- Added a change of wording to section **6.7.5 Phy reset sequence after devices are attached**.

Changes Since 06/05/2008

- *Added a proposed Informative Annex M for power supply logic reference design.*

Changes Since 07/11/2008

- *Edited most of the wording throughout the document to conform to the T10 style guide and to incorporate comments received from the group*
- *Deleted the minimum value for Supply Current in Table 61 and changed the maximum value from 600 mA to 319.4 mA.*
- *Edited the Informative Annex M to conform to the T10 style guide, dropped Table M.1 (parts List) and edited Figure M.1 to identify the function of the components.*

Changes Since 08/12/2008

- *Title and other references to the specification is now 2.1 instead of 2.x*
- *The pinout of active mini SAS cables has been changed in Table 60: the Sense pin is now B1 instead of B10, and pin B10 reverts to ground. The change is also reflected in Figure M.1 of Annex M.*
- *Changed the wording of the last paragraph of 5.2.7.1 from*
“The specification of high-speed data transmission performance of these cables is beyond the scope of this standard. The design of active cables shall operate with the transmitter and receiver defined in section 5.3 of this standard.”
to
“The specification of high-speed data transmission performance of these cables is beyond the scope of this standard. The design of active cables shall operate with all transmitter and receiver devices defined in this standard, which includes support of OOB signaling.”
- *Added key slot in position 3 (per Molex’s proposal for SAS-2.0 cable keying) to Table 59 and corresponding wording in 5.2.7.2.2.1 and 5.2.7.2.2.2.*
- *Changed the wording of 5.2.7.3.4 from*
“The active cable power supply shall have protection against the connection of the Vcc pin to ground or over-current loading, and shall limit the output current when the equivalent load resistance is less than 1 Ohm”
to
“The active cable power supply shall have protection against the connection of the Vcc pin to ground or over-current loading, and shall limit the output current when the supply voltage drops below 2.3 V.”

Changes Since 08/27/2008

- *Added details of new keying scheme incorporating blocking key in position 5 on the plug and key slots 3 and 5 on receptacle. Updated Figure 98, Table 58 and Table 59 accordingly, added figures 99-101.*
- *Changed the wording in second paragraph of 5.2.7.2.2.1 and second paragraph of 5.2.7.2.2.2 to describe the keying scheme.*
- *Changed the wording of 5.2.7.3.4 from
“The active cable power supply shall have protection against the connection of the Vcc pin to ground or over-current loading, and shall limit the output current when the supply voltage drops below 2.3 V.”
to
“The active cable power supply shall have protection against the connection of the Vcc pin to ground or over-current loading.”*

Changes Since 09/04/2008

- *Changed details of active plug keying scheme to differentiate between plugs attaching to enclosure in and enclosure out ports. Updated Figure 98, Table 58 and Table 59 accordingly, added Figure 99, renumbered subsequent figures to be 100-102.*

Changes Since 09/05/2008

- *Fixed a typo: in Table 58, Column 1, Row 2 refers to enclosure in, not enclosure out port.*

List of Proposed Modifications to SAS 2.0 to Enable Active Cables

- The title of section 5.2 “Passive Interconnect” shall be changed to read “Interconnect Characteristics”.
- The title of subsection 5.2.4 “Cable assemblies” shall be changed to read “Passive Cable assemblies”.
- The title of subsection 5.2.6 “Cable assembly and backplane specifications” shall be changed to read “Passive cable assembly and backplane specifications”.
- A subsection 5.2.7 titled “Active Cables” shall be inserted with text as per pages 3-7 of this document.
- The table numbering in section 5.3 and onwards shall be changed so that Table 57 becomes Table 62, etc.
- The figure numbering in section 5.3 and onwards shall be changed so that Figure 98 becomes Figure 103, etc.
- Section 6.7.5 shall be reworded from the original text

6.7.5 Phy reset sequence after devices are attached

Since SATA and SAS signal cable connectors do not include power lines, it is not possible to detect the physical insertion of the signal cable connector onto a plug. Non-cabled environments may similarly not have a way to detect physical insertion of a device. As a result, every time a phy reset sequence is originated:

- a) expander phys that are enabled but not active shall originate a new phy reset sequence repeatedly, with no more than a hot-plug timeout (see table 93 in 6.7.1) between each attempt, until a speed negotiation sequence completes successfully;
- b) SAS initiator phys should originate a new phy reset sequence after every hot-plug timeout; and
- c) SAS target phys should not originate a new phy reset sequence after their first attempt.

to read:

6.7.5 Phy reset sequence after devices are attached

Since it is not always possible to detect physical mating of a cable, every time a phy reset sequence is originated:

- a) expander phys that are enabled but not active shall originate a new phy reset sequence repeatedly, with no more than a hot-plug timeout (see table 94 in 6.7.1) between each attempt, until a speed negotiation sequence completes successfully;
- b) SAS initiator phys should originate a new phy reset sequence after every hot-plug timeout; and
- c) SAS target phys should not originate a new phy reset sequence after their first attempt

5.2.7 Active cables

5.2.7.1 Active cable overview

The standard provides support for the cable assemblies which incorporate active circuitry. This includes but is not limited to cables with built-in drivers, repeaters, equalizers, as well as copper cable substitutes which incorporate electro-optical converters and optical transceivers.

In order to enable the operation of devices inside the active cable assemblies, 3.3 V power supply option is made available in the connectors.

The powered ports receptacles defined in this standard are required to function when passive cables are plugged into them. This means that they must be able to handle the condition where their power supply pins are shorted to ground for any arbitrary length of time. Therefore, voltage sense pins are used to enable the switching of power in these ports.

Active cable assemblies defined in this standard, when plugged into unpowered SAS 2.0 receptacles will not function.

All active cables defined in this standard are external cable assemblies with active connectors defined in 5.2.7.2.

The specification of high-speed data transmission performance of these cables is beyond the scope of this standard. The design of active cables shall operate with all transmitter and receiver devices defined in this standard, which includes support of OOB signaling.

5.2.7.2 Active connectors

5.2.7.2.1 SAS 4x active connectors

5.2.7.2.1.1 SAS 4x active plug connector

The SAS 4x active cable plug connector is the connector defined in 5.2.3.3.1.1) and shown in figure 74.

5.2.7.2.1.2 SAS 4x active receptacle connector

The SAS 4x active receptacle connector is the connector defined in 5.2.3.3.1.1 and shown in figure 75.

5.2.7.2.1.3 SAS 4x active connector pin assignments

Table 57 defines the pin assignments for SAS 4x cable plug connectors (see 5.2.7.2.1.1) and SAS 4x receptacle connectors (see 5.2.7.2.1.2) for applications using one, two, three, or four of the physical links.

Table 57 — SAS 4x active connector pin assignments and physical link usage

Signal	Pin usage based on number of physical links supported by the cable assembly ^a			
	One	Two	Three	Four
Rx 0+	S1	S1	S1	S1
Rx 0-	S2	S2	S2	S2
Rx 1+	N/C	S3	S3	S3
Rx 1-	N/C	S4	S4	S4
Rx 2+	N/C	N/C	S5	S5
Rx 2-	N/C	N/C	S6	S6
Rx 3+	N/C	N/C	N/C	S7
Rx 3-	N/C	N/C	N/C	S8
Tx 3-	N/C	N/C	N/C	S9
Tx 3+	N/C	N/C	N/C	S10
Tx 2-	N/C	N/C	S11	S11
Tx 2+	N/C	N/C	S12	S12
Tx 1-	N/C	S13	S13	S13
Tx 1+	N/C	S14	S14	S14
Tx 0-	S15	S15	S15	S15
Tx 0+	S16	S16	S16	S16
Sense-3.3V	G7			
Vcc	G8			
SIGNAL GROUND	G1 – G6, G9			
CHASSIS GROUND	Housing			
^a N/C = not connected				

SIGNAL GROUND shall not be connected to CHASSIS GROUND in the connector when used in a cable assembly.

5.2.7.2.2 Mini SAS 4x active connectors

5.2.7.2.2.1 Mini SAS 4x active cable plug connector

The Mini SAS 4x active cable plug connector is the free (plug) 26-circuit Shielded Compact Multilane connector defined in SFF-8088.

In order to ensure that active cables are not intermateable with passive receptacles, differentiating keying shall be provided by having key slots in positions 2, 4 and 6 and a blocking key in position 5 on the plug connector, and key slots in positions 3 and 5 on the receptacle connector in addition to keys 2, 4 or 6 used identify a receptacle for an enclosure out, in or universal port. In addition, two triangle icons on each side on the plug connector shall be added to the plug connector to identify an active cable assembly. The plug connector key positions and icons are summarized in Table 58.

Table 58 — Mini SAS 4x active cable plug connector icons and key slot positions

Use	Icon	Key slot positions	Key positions	Reference
End of a SAS external cable that attaches to an end device, an enclosure out port, or an enclosure universal port	2 Triangles and a Diamond	2,4	5	Figure 98
End of a SAS external cable that attaches to an end device, an enclosure in port, or an enclosure universal port	2 Triangles and a Circle	4,6	5	Figure 99

Figure 98 shows an active mini SAS 4x cable plug connector that attaches to an enclosure out or universal port:

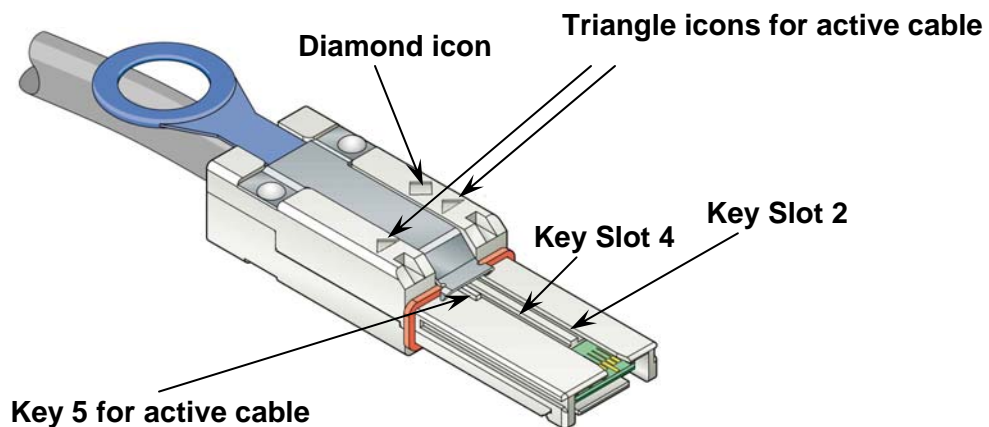

Figure 98 — Mini SAS 4x active cable plug connector that attaches to an enclosure out port

Figure 99 shows an active mini SAS 4x cable plug connector that attaches to an enclosure in or universal port:

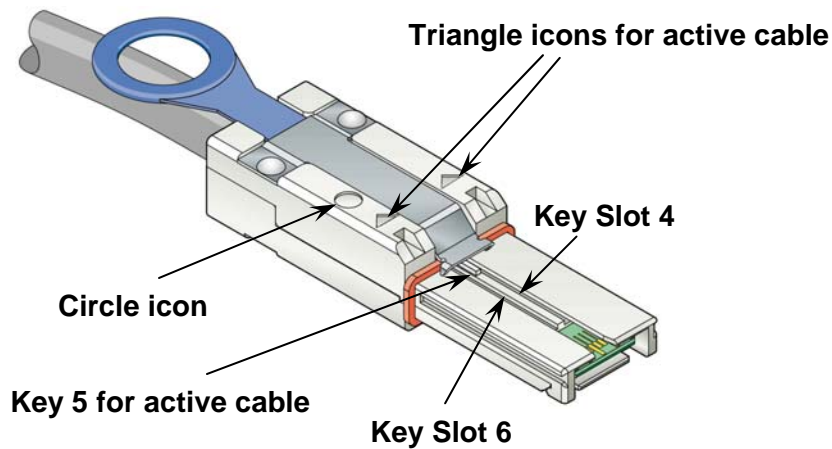

Figure 99 — Mini SAS 4x active cable plug connector that attaches to an enclosure in port

5.2.7.2.2.2 Mini SAS 4x active receptacle connector

The Mini SAS 4x active receptacle connector is the fixed (receptacle) 26-circuit Shielded Compact Multilane connector defined in SFF-8088 and shown in figures 99-101.

In order to ensure that active cables are not intermateable with passive receptacles, differentiating keying shall be provided by having key slots in positions 2, 4 and 6 and a blocking key in position 5 on the plug connector, and key slots in positions 3 and 5 on the receptacle connector in addition to keys 2, 4 or 6 used identify a receptacle for an enclosure out, in or universal port. In addition, two triangle icons on each side on the plug connector shall be added to the plug connector to identify an active cable assembly. The plug connector key positions and icons are summarized in Table 58.

The receptacle connector key positions and icons are summarized in Table 59.

Table 59 — Mini SAS 4x active cable receptacle connector icons and key slot positions

Use	Icon	Key positions	Key slot positions	Reference
End device or enclosure universal port	2 Triangles, Diamond and a Circle	4	3, 5	Figure 99
Enclosure out port (see 4.6.2)	2 Triangles and a Diamond	2	3, 5	Figure 100
Enclosure in port (see 4.6.2)	2 Triangles and a Circle	6	3, 5	Figure 101

Figure 100 shows an active Mini SAS 4x receptacle connector used by end devices or an enclosure universal port.

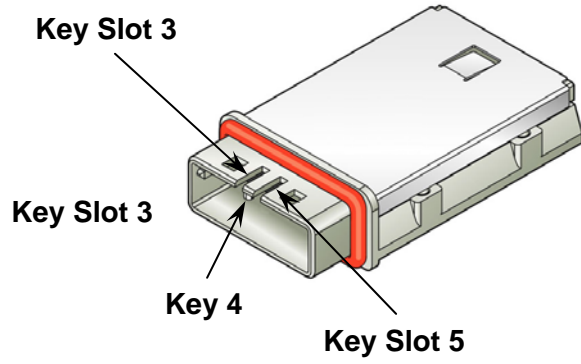

Figure 99 — Mini SAS 4x active receptacle connector - end device or enclosure universal port

Figure 101 shows an active Mini SAS 4x receptacle connector used by an enclosure out port.

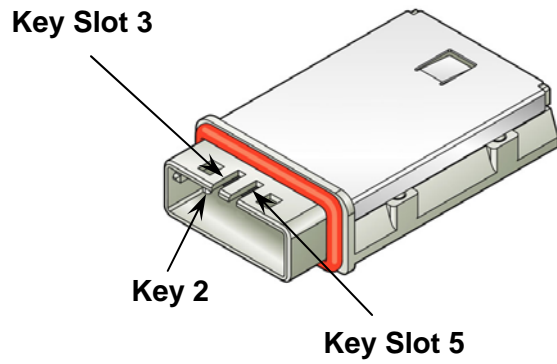

Figure 101 — Mini SAS 4x active receptacle connector - enclosure out port

Figure 102 shows an active Mini SAS 4x receptacle connector used by an enclosure in port.

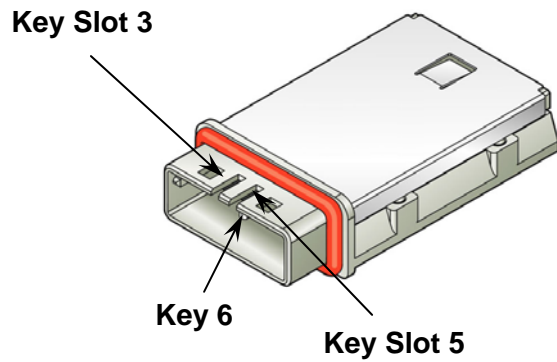

Figure 102 — Mini SAS 4x active receptacle connector - enclosure in port

5.2.7.2.2.3 Mini SAS 4x active connector pin assignments

Table 60 defines the pin assignments for Mini SAS 4x cable plug connectors (see 5.2.7.2.2.1) and Mini SAS 4x receptacle connectors (see 5.2.7.2.2.2) for applications using one, two, three, or four of the physical links.

Table 60 — Mini SAS 4x active connector pin assignments and physical link usage

Signal	Pin usage based on number of physical links supported by the cable assembly ^a				Mating level
	One	Two	Three	Four	
Rx 0+	A2	A2	A2	A2	Third
Rx 0-	A3	A3	A3	A3	
Rx 1+	N/C	A5	A5	A5	
Rx 1-	N/C	A6	A6	A6	
Rx 2+	N/C	N/C	A8	A8	
Rx 2-	N/C	N/C	A9	A9	
Rx 3+	N/C	N/C	N/C	A11	
Rx 3-	N/C	N/C	N/C	A12	
Tx 0+	B2	B2	B2	B2	
Tx 0-	B3	B3	B3	B3	
Tx 1+	N/C	B5	B5	B5	
Tx 1-	N/C	B6	B6	B6	
Tx 2+	N/C	N/C	B8	B8	
Tx 2-	N/C	N/C	B9	B9	
Tx 3+	N/C	N/C	N/C	B11	
Tx 3-	N/C	N/C	N/C	B12	
Sense 3.3 V	B1				First
Vcc	B13				
SIGNAL GROUND	A1, A4, A7, A10, A13, B4, B7, B10				
CHASSIS GROUND	Housing				
^a N/C = not connected					N/A

SIGNAL GROUND shall not be connected to CHASSIS GROUND in the connector when used in a cable assembly.

5.2.7.3 Active cable power requirements

5.2.7.3.1 Active cable power overview

Active SAS 4x and Mini SAS 4x cables may contain integrated active devices (e.g. drivers, repeaters, equalizers, as well as electro-optical converters and optical transceivers for fiber-optic assemblies). In order to enable the operation of active devices, 3.3 V power supply is provided.

Because active SAS 4x and Mini SAS 4x receptacle connectors must be intermateable with passive cables, sense pins are defined in order to avoid shorting the power supply (see Tables 57 and 60). The sense pins enable the power supply circuitry to turn on only when an active cable assembly is present, and to remain in the default off state when a passive cable or no cable is present. An example of a power supply logic circuitry design is provided in Annex M.

5.2.7.3.2 Power supply requirements

The voltage and current requirements for the power supply are such as to enable support for active cable assemblies with power consumption at 3.3 V of up to 1 W per each end of the cable with four functioning links. These requirements are summarized in Table 61.

Table 61 — Active cable power supply requirements

Characteristic	Units	Minimum	Nominal	Maximum
Supply Voltage	V	3.135 ^a	3.3	3.465 ^b
Supply Current	mA			319.4 ^c
Current Consumption	mA			288.6 ^d
Power Consumption	mW			1000 ^{d,e}

^a At maximum current
^b The power supply shall not exceed this value at any current
^c The power supply shall deliver this amount of current at the minimum voltage of 3.135 V.
^d Maximum consumption for each end of the active cable assembly at the maximum voltage of 3.465V.
^e This is a derivative quantity obtained from: (maximum supply voltage) x (maximum current consumption)

5.2.7.3.3 Voltage Sense

The active cable assembly shall provide a connection of the Sense pin to ground via a 5 kohm resistor (with tolerance $\pm 5\%$).

The active cable power supply circuitry shall enable power to the receptacle connector only when the presence of the Sense resistor is detected, and it shall be disabled if the Sense pin is open (i.e. no cable plugged in) or shorted to ground (i.e. passive cable).

5.2.7.3.4 Short Circuit Protection

The active cable power supply shall have protection against the connection of the Vcc pin to ground or over-current loading.

5.2.7.3.5 Hot-pluggable operation

In order to support hot plugging, the active cable power supply circuitry shall be able to detect the Sense resistor value and provide full current within 50 ms of cable connection.

5.2.7.3.6 Bypassing

The active cable power pins (i.e. Vcc and Sense) shall be coupled to ground via bypass capacitors so that they possess low impedance to ground from 100 MHz to 1.5 times the fundamental frequency of the maximum baud rate supported by the device. These bypassing capacitors shall be present both in the receptacle and the plug.

5.2.7.3.7 Capacitive coupling

In addition to bypassing, the power planes of the printed circuit board on the receptacle side shall be sufficiently coupled to ground.

5.2.7.3.8 Voltage Converters (DC-to-DC)

In implementations where the active circuitry in the cable requires voltages other than the provided 3.3 V, local voltage regulators may be used. These regulators shall be located within the active cable assembly.

Annex M (informative)

Active Cable Power Supply and Voltage Detection Circuitry

Powered mini-SAS devices supporting active cables need to operate with passive cables which have the Vcc pin tied to ground. Hence there needs to be a mechanism that turns on the power to the receptacle only when an active cable is plugged in, to avoid shorting the power supply. A voltage sense pin is implemented to detect if an active cable is in operation. This can also be used to detect the status a specific port, or implement other features within a switch device.

Fig M1 is an example design utilizing a dual comparator to determine from the sense pin on the active cable plug if an active cable is in operation. The circuit then supplies power based upon whether there is an active cable connected to the receptacle.

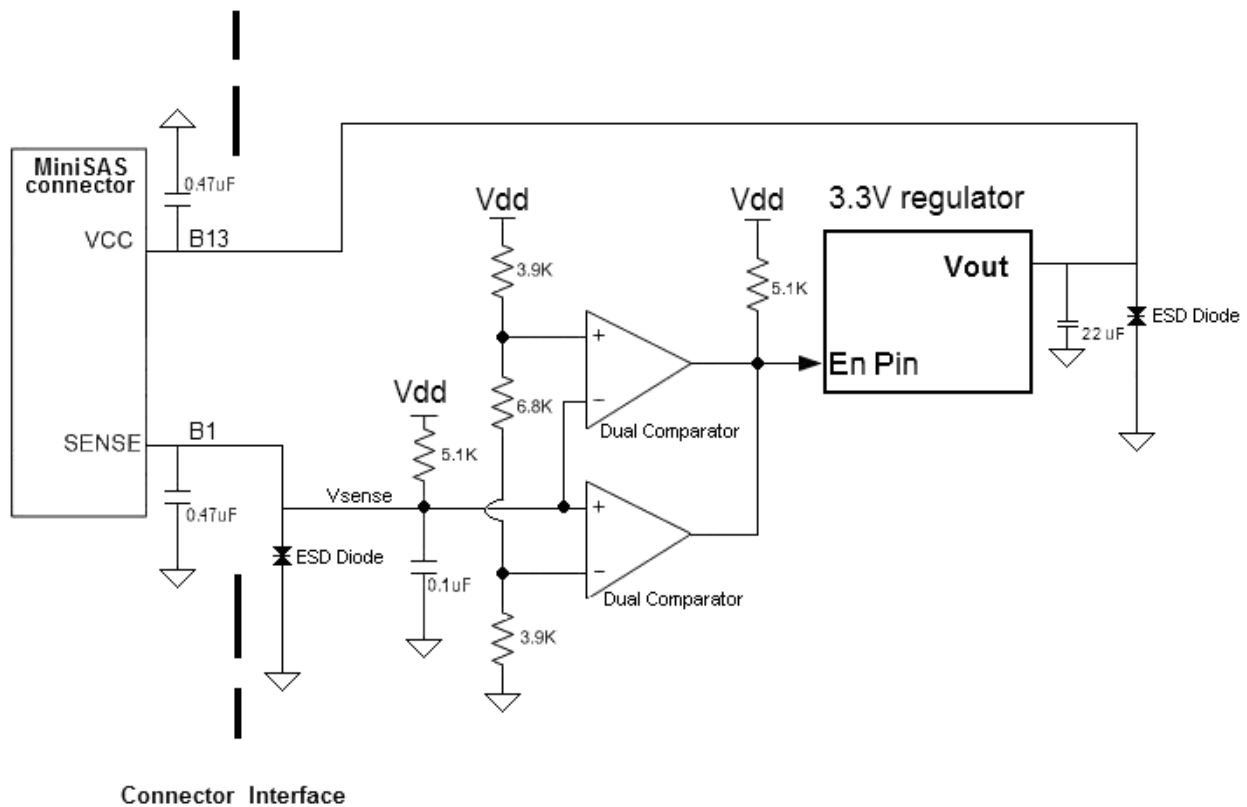

Figure M.1 — Dual comparator design for active cable detection

The power supply characteristics are specified in Table 61. The type of power delivery device may either be a switching or a linear regulator.