



Date: 20 August 2008
To: T10 Technical Committee
From: Ralph O. Weber
Subject: ISO/IEC RBC 2nd Edition FCD

ISO/IEC RBC 2nd Edition FCD

T10 Review Draft Only

Not an official ISO/IEC document

This document is a preliminary draft of ISO/IEC RBC 2nd Edition FCD (ISO/IEC 14776-326). This document is posted for review purposes only ... prior to IR submission to JTC1 for ISO/IEC processing. This document is not an official ISO/IEC document.

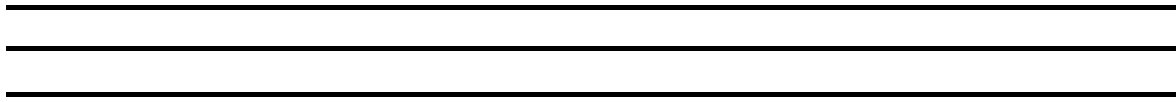

**Information technology - Small Computer System Interface— Part: 326
Reduced Block Commands (RBC), 2nd Edition**

Technologies de l'information — Interface small computer system —Partie 326: (RBC)

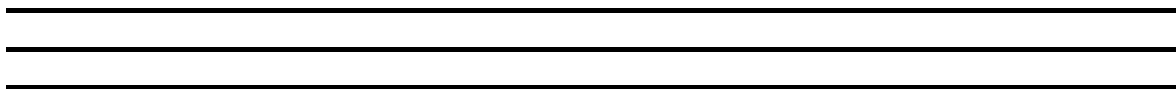

CONTENTS

Foreword.....	5
1 Scope and purpose	6
1.1 Scope	6
1.2 Purpose	6
2 Normative references	6
3 Definitions, Acronyms, Keywords, and Conventions	7
3.1 Definitions.....	7
3.2 Acronyms.....	8
3.3 Keywords	8
3.4 Conventions.....	9
3.4.1 Non-numeric values	9
3.4.2 Numeric values.....	9
4 RBC device model.....	9
4.1 General.....	9
4.2 Removable medium device.....	10
4.3 Command Usage.....	10
4.3.1 General	10
4.3.2 Using the INQUIRY command	11
4.3.3 Using the REQUEST SENSE command.....	11
4.3.4 FORMAT UNIT command progress determination.....	11
4.4 Using the PREVENT ALLOW MEDIUM REMOVAL command	11
4.4.1 General	11
4.4.2 START STOP UNIT command state restrictions	12
4.5 Logical Blocks.....	12
4.6 Reservations.....	13
5 Reduced Block Commands.....	14
5.1 General.....	14
5.2 FORMAT UNIT command	15
5.3 READ(10) Command	16
5.4 READ CAPACITY command	17
5.5 START STOP UNIT command	18
5.5.1 General	18
5.5.2 Power conditions	18
5.5.3 Control bits.....	19
5.6 SYNCHRONIZE CACHE command	20
5.7 WRITE(10) command	20
5.8 VERIFY command.....	22
5.9 MODE parameters.....	22
5.9.1 General	22
5.9.2 Mode parameter list.....	22
5.9.3 Mode Parameter header	23
5.9.4 RBC device parameter page	23
6 SPC-2 Implementation Requirements For RBC Devices	24

6.1	General	24
6.2	INQUIRY command.....	25
6.2.1	General.....	25
6.2.2	INQUIRY vital product data pages	26
6.3	MODE SELECT(6) command	26
6.3.1	General.....	26
6.3.2	SAVE PAGES (SP) bit support.....	26
6.4	MODE SENSE(6) command	27
6.5	PREVENT ALLOW MEDIUM REMOVAL	27
6.6	REQUEST SENSE command	27
6.7	TEST UNIT READY command.....	28
6.8	WRITE BUFFER Command.....	29
6.8.1	General.....	29
6.8.2	Download Microcode and save mode (101b)	29
6.8.3	Download Microcode with offsets and save mode (111b).....	29
7	Asynchronous Event Notification for RBC devices	30
7.1	General	30
7.2	Unit Attention.....	30
7.2.1	Power condition change notification.....	30
7.3	Deferred errors	31
7.4	Information exception condition notification	31
7.5	Event status notification.....	31
7.5.1	General.....	31
7.5.2	Event Status sense information	31
7.5.3	POWER MANAGEMENT CLASS INFORMATION field	32
7.5.4	MEDIA CLASS EVENT INFORMATION field	33
7.5.5	DEVICE BUSY CLASS Event Information Values	34
7.5.6	Event status retention	34
7.5.7	Removable Medium Device Initial Response.....	35
Annex A	(normative) RBC device implementation requirements for SBP-2.....	36
A.1	SBP-2 Definitions	36
A.2	Acronyms	37
A.3	SBP-2 storage model.....	37
A.3.1	General	37
A.3.2	Model configuration	38
A.3.3	Reconnect/Power reset support	39
A.4	Configuration ROM support.....	40
A.4.1	General	40
A.4.2	Unit Directory - Command_Set_Spec_ID	40
A.4.3	Unit Directory - Command_Set.....	40
A.4.4	Unit Directory - Logical_Unit_Number.....	40
A.5	Security support	40
A.6	Status block support	41
A.7	Unsolicited Status support	41
A.7.1	General	41
A.7.2	Unit attention condition	41
A.7.3	Event Status retention	41

Bibliography	42
--------------------	----

Tables

Table 1 - RBC direct access commands that are allowed in the presence of various reservations	13
Table 2 – Reduced Block Command set	14
Table 3 – FORMAT UNIT command	15
Table 4 – READ (10) Command Descriptor Block	16
Table 5 – READ CAPACITY Command Descriptor Block	17
Table 6 – READ CAPACITY data	17
Table 7 – START STOP UNIT Command Descriptor Block	18
Table 8 – POWER CONDITIONS	18
Table 9 – START STOP control bit definitions	19
Table 10 - SYNCHRONIZE CACHE Command Descriptor Block	20
Table 11 – WRITE(10) Command Descriptor Block	21
Table 12 – VERIFY Command Descriptor Block	22
Table 13 – Mode parameter list	22
Table 14 – RBC Device Parameters page format	23
Table 15 – Required SPC-2 commands	24
Table 16 – Standard Inquiry data format	25
Table 17 – MODE SELECT(6) Command Descriptor Block	26
Table 18 – MODE SENSE(6) Command Descriptor Block	27
Table 19 – FAILURE PREDICTION ASCQ XY definitions	28
Table 20 – WRITE BUFFER Command Descriptor Block	29
Table 21 - Asynchronous Event conditions	30
Table 22 – Power condition sense code and qualifier values	30
Table 23 – Event status ASCQ values	31
Table 24 - Event Status INFORMATION field format	32
Table 25 - POWER MANAGEMENT CLASS INFORMATION field format	32
Table 26 - POWER MANAGEMENT CLASS EVENT field	32
Table 27 - POWER MANAGEMENT CLASS STATUS field	33
Table 28 - MEDIA CLASS INFORMATION field format	33
Table 29– MEDIA CLASS EVENT field	33
Table 30 – DEVICE BUSY CLASS INFORMATION field format	34
Table 31 – DEVICE BUSY CLASS EVENT field	34
Table 32 - DEVICE BUSY CLASS STATUS field	34

Foreword

- 1) ISO (International Organization for Standardization) and IEC (International Electrotechnical Commission) form the specialized system for worldwide standardization. National bodies that are members of ISO or IEC participate in the development of International Standards through technical committees established by the respective organization to deal with particular fields of technical activity. ISO and IEC technical committees collaborate in fields of mutual interest. Other international organizations, governmental and non-governmental, in liaison with ISO and IEC, also take part in the work.
- 2) In the field of information technology, ISO and IEC have established a joint technical committee, ISO/IEC JTC 1. Draft International Standards adopted by the joint technical committee are circulated to national bodies for voting. Publication as an International Standard requires approval by at least 75 % of the national bodies casting a vote.
- 3) All users should ensure that they have the latest edition of this publication.
- 4) No liability shall attach to IEC or ISO or its directors, employees, servants or agents including individual experts and members of their technical committees and IEC or ISO member bodies for any personal injury, property damage or other damage of any nature whatsoever, whether direct or indirect, or for costs (including legal fees) and expenses arising out of the publication of, use of, or reliance upon, this ISO/IEC publication or any other IEC, ISO or ISO/IEC publications.
- 5) Attention is drawn to the normative references cited in this publication. Use of the referenced publications is indispensable for the correct application of this publication.
- 6) Attention is drawn to the possibility that some of the elements of this International Standard may be the subject of patent rights. ISO and IEC shall not be held responsible for identifying any or all such patent rights.

International Standard ISO/IEC 14776-326 was prepared by subcommittee 25: Interconnection of information technology equipment, of ISO/IEC joint technical committee 1: Information technology.

This publication has been drafted in accordance with the ISO/IEC Directives, Part 2.

INFORMATION TECHNOLOGY - SMALL COMPUTER SYSTEM INTERFACE — PART 326: REDUCED BLOCK COMMANDS (RBC)

1 Scope and purpose

1.1 Scope

This standard defines a Reduced Block Command set for logical block devices. The Reduced Block Commands along with the required SPC-2 commands and their restrictions described in this standard, fully specify the complete command set for RBC logical block devices.

1.2 Purpose

The purpose of this document is to provide a command set of reduced requirements and options from SCSI Block Commands (SBC) (ISO/IEC 14776-321) for block devices. The reduced command set is intended to more closely match the functionality required for simple block logical units. The specified commands place no restrictions on device performance. The initial focus of this command set was rigid disks and removable media devices attached to Serial Bus and utilizing SBP-2 (ISO/IEC 14776-232) for command and control.

2 Normative references

The following referenced documents are indispensable for the application of this document. For dated references, only the edition cited applies. For undated references, the latest edition of the referenced document, including any amendments, applies.

The provisions of the referenced specifications other than ISO/IEC, IEC, ISO and ITU documents, as identified in this clause, are valid within the context of this International Standard. The reference to such a specification within this International Standard does not give it any further status within ISO/IEC. In particular, it does not give the referenced specification the status of an International Standard.

ISO/IEC 14776-232:2001, Information Technology - Small Computer System Interface (SCSI) – Part 232: Serial Bus Protocol 2 (SBP-2)

ISO/IEC 14776-452:2001, Information Technology – Small Computer System Interface (SCSI) – Part 452: SCSI Primary Commands (SPC-2)

ISO/IEC 14776-321:2001, Information Technology - Small Computer System Interface (SCSI) – Part 321: SCSI-3 Block Commands (SBC)

ISO/IEC 14776-362:2006, Information Technology - Small Computer System Interface (SCSI) – Part 362: MultiMedia Command Set 2 (MMC-2)

ISO/IEC 13213:1994, Control and Status Register (CSR) Architecture for Microcomputer Buses

ANSI/IEEE 1394-1995, High Performance Serial Bus

IEEE P1394x, Draft Standard for a High Performance Serial Bus (Supplement) (under consideration) ¹⁾

¹⁾ Available from Institute of Electrical and Electronics Engineers, 445 Hoes Lane, P.D. Box 1331, Piscataway, NJ 08855-1331.

3 Definitions, Acronyms, Keywords, and Conventions

3.1 Definitions

For the purpose of this international standard, the following definitions apply.

3.1.1

additional sense code

field in the sense data (see Glossary definition in SPC-2).

3.1.2

additional sense code qualifier

field in the sense data (see Glossary definition in SPC-2).

3.1.3

Byte

eight bits of data.

3.1.4

command descriptor block

structure of up to 16 bytes in length used to communicate a command from an initiator to a device.

3.1.5

event field

Byte 0 of the sense data INFORMATION field (see Table 24 for the Event Status INFORMATION field format) when the sense code indicates EVENT STATUS NOTIFICATION (38h).

3.1.6

logical unit

part of the target that is an instance of a device model, e.g., mass storage, CD-ROM or printer. In devices that implement one or more logical units, the device type of the logical units may differ.

3.1.7

sense data

Data describing an error or exceptional device condition that a device delivers to an initiator (see Glossary definition in SPC-2).

3.1.8

sense key

field in the sense data (see Glossary definition in SPC-2).

3.1.9

Status

response information sent from a device to an initiator upon completion of each command.

3.1.10

unit attention condition

state that a logical unit maintains while it has asynchronous status information to report to one or more initiators.

3.1.11

vendor-specific

something (e.g. a bit, field, code value, etc.) that is not defined by this standard and may be vendor defined.

3.2 Acronyms

The following are abbreviations that are used in this standard:

ASC	Additional Sense Code
ASCQ	Additional Sense Code Qualifier
CDB	Command Descriptor Block
RBC	Reduced Block Commands (this standard)
SPC-2	SCSI Primary Commands 2

3.3 Keywords

Several keywords are used to differentiate levels of requirements and options, as follows:

3.3.1

expected

keyword used to describe the behavior of the hardware or software in the design models assumed by this standard. Other hardware and software design models may also be implemented.

3.3.2

ignored

keyword that describes bits, bytes, quadlets, or fields whose values are not checked by the recipient.

3.3.3

mandatory

keyword that indicates items required to be implemented as defined by this standard.

3.3.4

may

keyword that indicates flexibility of choice with no implied preference.

3.3.5

optional

keyword that describes features which are not required to be implemented by this standard. However, if any optional feature defined by the standard is implemented, it shall be implemented as defined by the standard.

3.3.6

reserved

keyword used to describe objects—bits, bytes, and fields—or the code values assigned to these objects in cases where either the object or the code value is set aside for future standardization. Usage and interpretation may be specified by future extensions to this or other standards. A reserved object shall be zeroed or, upon development of a future standard, set to a value specified by such a standard. The recipient of a reserved object shall not check its value. The recipient of a defined object shall check its value and reject reserved code values.

3.3.7

shall

keyword that indicates a mandatory requirement. Designers are required to implement all such mandatory requirements to assure interoperability with other products conforming to this standard.

3.4 Conventions

The following conventions shall be understood by the reader in order to comprehend this standard.

3.4.1 Non-numeric values

Lowercase is used for words having the normal English meaning. Certain words and terms used in this standard have a specific meaning beyond the normal English meaning. These words and terms are defined either in Clause 3 or in the text where they first appear.

Listed items in RBC do not represent any priority. Any priority is explicitly indicated. Formal lists e.g., (a) red; (b) blue; (c) green) connoted by letters are in an arbitrary order. Formal lists e.g., (1) red; (2) blue; (3) green) connoted by numbers are in a required sequential order.

If a conflict arises between text, tables, or figures, the order of precedence to resolve conflicts is text; then tables; and finally figures. Not all tables or figures are fully described in text. Tables show data format and values. Notes and IMPLEMENTATION Notes do not constitute any requirements for implementations.

- a) The names of abbreviations, commands, and acronyms are in all uppercase, e.g. TEST UNIT READY command.
- b) Fields containing only one bit are usually referred to as the "NAME" bit instead of the "NAME" field.
- c) Fields are shown in caps, e.g. LOGICAL BLOCK ADDRESS.

3.4.2 Numeric values

The ISO convention of numbering is used (i.e., the thousands and higher multiples are separated by a space and a comma is used as the decimal point as in 65 536 or 0,5).

- a) Decimal numbers are represented by Arabic numerals without subscripts or by their English names, e.g. 42, or twelve.
- b) Hexadecimal numbers are represented by digits from the character set 0 – 9 and A – F followed by the lower-case h, e.g. 2Ah.
- c) Binary numbers are represented by digits from the character set 0 and 1 followed by the lower-case b, e.g. 0010 1010b.
- d) The most significant bit of a binary quantity is shown on the left side and represents the highest algebraic value position in the quantity.
- e) For the sake of legibility, binary and hexadecimal numbers are separated into groups of four digits separated by spaces.

4 RBC device model

4.1 General

RBC logical units store blocks of data for later retrieval. Each block of data is stored at a unique location. Initiators issue WRITE commands to store the blocks of data (write operations) and READ commands to retrieve the blocks of data (read operations). Other commands issued by the initiator may also cause write and read operations to occur. A write operation causes one or more blocks of data to be written on the medium. A read operation causes one or more blocks of data to be read from the medium. A verify operation confirms that one or more blocks of data were correctly written and may be read without error from the medium.

Blocks of data are stored by a process that causes localized changes or transitions within the medium. The changes made to the medium to store the blocks of data may be volatile

(i.e. not retained through off/on power cycles) or non-volatile (retained through off/on power cycles). The medium may be divided in parts that are used for data blocks, parts that are reserved for defect management, and parts that are reserved for use by the target for the management of the logical unit.

4.2 Removable medium device

The medium in a RBC device may be removable (e.g., used in a floppy disk drive) or non-removable (e.g. used in a fixed disk drive). Typically, removable medium is contained within a cartridge (or jacket) to prevent damage to the recording surfaces.

A removable medium has an attribute of being mounted or de-mounted on a suitable transport mechanism. A removable medium is mounted when the device/media combination is capable of performing write or read operations and the initiator is informed of this status. A removable medium is de-mounted at any other time (e.g., during loading, unloading, or storage).

Initiators may determine whether a RBC removable medium device is capable of performing read or write operations by one of three methods:

- a) Enabling AERC in the device and examining the event information transmitted from the device.
- b) Issuing a TEST UNIT READY command and examining the returned status information.
- c) Issuing a MODE SENSE command for Mode Page 06h (see 5.9.4) and examining the state of the READD or WRITED bits in byte 11. If the READD bit is set to one, then the media is not readable. If the WRITED bit is set to one, then the media is not writable.

Until the RBC removable medium device and media are ready to be accessed, a READ(10) command shall cause the device to return status of CHECK CONDITION (02h), sense key of NOT READY (02h), and an ASC of LOGICAL UNIT NOT READY (04h). The ASCQ shall reflect the current state of the device/media.

When the device becomes ready, a unit attention condition shall be established. The sense key field shall be set to UNIT ATTENTION (06h), and the ASC/ASCQ to EVENT STATUS NOTIFICATION/MEDIA CLASS EVENT (38h/04h). The EVENT field contained within the SENSE DATA INFORMATION field shall be set to NEW MEDIA READY FOR ACCESS (02h). When the unit attention condition is delivered to the initiator, the status field shall be set to CHECK CONDITION (02h).

4.3 Command Usage

4.3.1 General

RBC devices are not required to support the REQUEST SENSE command or the SEND DIAGNOSTIC command. Devices that do not provide the Auto Sense function, Asynchronous Event Reporting, or the GET EVENT STATUS NOTIFICATION (See MMC-2 for definition) command shall implement the REQUEST SENSE command.

All SENSE KEY, ADDITIONAL SENSE CODE, and ADDITIONAL SENSE CODE QUALIFIER names and values contained in this standard are defined in SPC-2. No additional or alternative meaning is intended by the use of such names and values in this standard.

4.3.2 Using the INQUIRY command

The INQUIRY command may be used by an initiator to determine the configuration of a logical unit. RBC devices return information that includes type and standard version. The device may also return the vendor identification number, model number, and other vendor specific information. It is recommended that devices provide the capability to return this information upon completing power-on initialization. A device may take more time to return certain portions of this information, especially if the information must be retrieved from the medium.

4.3.3 Using the REQUEST SENSE command

Whenever a command completes with CHECK CONDITION status and AUTSENSE Data is not provided, the initiator that received the error status should issue a REQUEST SENSE command to acquire the sense data describing the cause of the condition. If the initiator issues a command other than REQUEST SENSE, the sense data is lost.

Devices may be required to support the REQUEST SENSE command if they are unable to provide command progress information by any other method.

4.3.4 FORMAT UNIT command progress determination

The FORMAT UNIT command requires IMMEDIATE bit support because it may consume significantly more time to complete than normal read or write commands. If the IMMEDIATE bit is one, the device is required to return status as soon as the command descriptor block is validated. The device then completes the format operation. Initiators may determine the progress of the format operation in several ways.

RBC devices may provide format progress information using one of three methods. The first two mechanisms return data in the Event Status Notification format described in 7.5.6.

The first mechanism is progress reporting via Asynchronous Event Reporting. If the initiator and device support this feature, the RBC device initiates progress reporting.

The second mechanism is progress reporting via the GET EVENT STATUS NOTIFICATION(See MMC-2 for command definition) command. Following the return of GOOD status, the initiator may poll the device for command progress by issuing a GET EVENT STATUS NOTIFICATION command. The returned data contains progress information as defined in 7.5.6

The third mechanism is progress reporting via the PROGRESS INDICATION field in the sense-key specific bytes of REQUEST SENSE command sense data. See the SPC-2 standard for a description of this method.

4.4 Using the PREVENT ALLOW MEDIUM REMOVAL command

4.4.1 General

The PREVENT ALLOW MEDIUM REMOVAL command allows an initiator to restrict the de-mounting of the medium. This is useful in maintaining system integrity. If the removable medium device implements cache memory, the command allows the initiator to ensure that all logical blocks of the medium contain the most recent data prior to permitting de-mounting of the removable medium.

If the initiator issues a START STOP UNIT command to eject the cartridge, and the removable medium device is prevented from de-mounting by the PREVENT ALLOW MEDIUM REMOVAL command, the START STOP unit command is rejected by the device.

When set to one, the RMB bit in the standard INQUIRY command data, indicates the PREVENT ALLOW MEDIUM REMOVAL command is not be supported.

4.4.2 START STOP UNIT command state restrictions

A removable medium device shall be in either PREVENT state 00b or 10b in order to successfully execute a START STOP UNIT command with the POWER CONDITIONS field set to the Sleep state (5).

If a removable medium device, in either PREVENT state 01b or 11b, receives a START STOP UNIT command with the POWER CONDITIONS field set to the Sleep state (5), the device shall respond with status set to CHECK CONDITION (02h), the sense key to ILLEGAL REQUEST (05h), and the ASC/ASCQ to ILLEGAL POWER CONDITION REQUEST (2Ch/05h).

A removable medium device in the SLEEP State shall eject the media without causing the media to spin up in accordance with the PREVENT/ALLOW MEDIUM REMOVAL command requirements.

Refer to clause 6 for a description of the POWER CONDITIONS field values.

4.5 Logical Blocks

Data are addressed on the RBC device in a group referred to as a Logical Block. This is a common attribute of RBC devices in that they are block addressable only.

Blocks of data are stored on the medium along with additional information that the medium controller uses to manage the storage and retrieval of the blocks. The format of the additional information is defined by other standards or is vendor specific and is hidden from the application client during normal read or write operations.

The address of the first logical block is zero. The address of the last logical block is [n-1], where [n] is the number of logical blocks available on the medium. A READ CAPACITY command may be issued to determine the value of [n-1]. If a command is issued that requests access to a logical block not within the capacity of the medium, the command is terminated with a status of CHECK CONDITION (02h), a sense key of ILLEGAL REQUEST (05h), and an ASC/ASCQ of LOGICAL BLOCK ADDRESS OUT OF RANGE (21h/00h).

The number of bytes of data contained in a logical block is known as the block length. Each logical block has a block length associated with it. The block length is almost always greater than one byte and is typically (but by no means always) a multiple of 512 bytes. In addition, a logical block does not necessarily bear any relation to the physical block size of the storage medium.

The LOGICAL BLOCK SIZE field in the RBC Device Parameters MODE SENSE page (see Table 14) describes the block length that is used on the medium. A MODE SELECT command may be used to set the logical block size, if the field is changeable.

The default NUMBER OF LOGICAL BLOCKS value in the may be obtained by requesting the Default MODE SENSE data for the RBC Device Parameters MODE SENSE page. The current NUMBER OF LOGICAL BLOCKS value may be obtained by requesting the saved MODE SENSE data for this page.

The location of a logical block on the medium does not necessarily have a relationship to the location of any other logical block. However, in a typical logical unit the logical blocks are located in an ascending order. The time to access the logical block at address [x] and

then the logical block at address [x+1] need not be less than time to access [x] and then [x+100].

4.6 Reservations

If the bus protocol does not inherently provide the ability to reserve and release access to a device, then this function may be supported by the RESERVE and RELEASE commands.

Reservation restrictions are placed on commands as a result of access qualifiers associated with the type of reservation.

The details of what commands are allowed under what types of reservations are described in Table 1. For the reservation restrictions placed on commands for the Reserve/Release management method see Table 1 column [A]. For the reservation restrictions placed on commands for the Persistent Reservations management method, see the columns under [B] in Table 1. In Table 1 the following key words are used:

allowed: Commands issued by initiators not holding the reservation or by initiators not registered when a registrants only persistent reservation is present should complete normally.

conflict: Commands issued by initiators not holding the reservation or by initiators not registered when a registrants only persistent reservation is present shall not be performed and the device server shall terminate the command with a RESERVATION CONFLICT status.

Commands from initiators holding a reservation should complete normally. The behavior of commands from registered initiators when a registrants only persistent reservation is present is specified in Table 1.

A command that does not explicitly write the medium shall be checked for reservation conflicts before the command enters the current task state for the first time. Once the command has entered the current task state, it shall not be terminated with a RESERVATION CONFLICT due to a subsequent reservation.

A command that explicitly writes the medium shall be checked for reservation conflicts, before the device server modifies the medium or cache as a result of the command. Once the command has modified the medium, it shall not be terminated with a RESERVATION CONFLICT due to a subsequent reservation. For each command, this standard, SPC-2, or a related command standard defines the conditions that result in RESERVATION CONFLICT. Depending on the particular command standard the conditions are defined in that standard’s device model clause or in the clauses that define the specific commands.

Table 1 - RBC direct access commands that are allowed in the presence of various reservations

Command	Addressed LU is reserved by another Initiator (A)	Addressed LU has this type of persistent reservation held by another Initiator (B)				
		From any Initiator		From registered Initiator (RO all types)	From Initiator not registered	
		Write Excl	Excl Access		Write Excl - RO	Excl Access - RO
FORMAT UNIT	Conflict	Conflict	Conflict	Allowed	Conflict	Conflict

READ (10)	Conflict	Allowed	Conflict	Allowed	Allowed	Conflict
READ CAPACITY	Allowed	Allowed	Allowed	Allowed	Allowed	Allowed
START STOP UNIT Start = 0 and Power Condition = 0	Allowed	Allowed	Allowed	Allowed	Allowed	Allowed
START STOP UNIT Start = 1 or Power Condition <>0	Conflict	Conflict	Conflict	Allowed	Conflict	Conflict
VERIFY (10)	Conflict	Allowed	Conflict	Allowed	Allowed	Conflict
WRITE (10)	Conflict	Conflict	Conflict	Allowed	Conflict	Conflict

5 Reduced Block Commands

5.1 General

The Reduced Block Command set (RBC) for block device logical units is shown in Table 2. The SCSI Primary Commands (SPC-2) required for RBC device implementations are also shown in Table 2. Support is indicated for fixed or removable drives.

Table 2 – Reduced Block Command set

Command name	OpCode	Command Support		Reference
		Fixed	Removable	
FORMAT UNIT	04h	O	O	RBC
INQUIRY	12h	M	M	SPC-2 ¹
MODE SELECT(6)	15h	M	M	SPC-2 ¹
MODE SENSE(6)	1Ah	M	M	SPC-2 ¹
PERSISTENT RESERVE IN	5Eh	O	O	SPC-2 ¹
PERSISTENT RESERVE OUT	5Fh	O	O	SPC-2 ¹
PREVENT/ALLOW MEDIUM REMOVAL	1Eh	N/A	M	SPC-2 ¹
READ (10)	28h	M	M	RBC
READ CAPACITY	25h	M	M	RBC
RELEASE(6)	17h	O	O	SPC-2 ¹
REQUEST SENSE	03h	O	O	SPC-2 ¹
RESERVE(6)	16h	O	O	SPC-2 ¹
START STOP UNIT	1Bh	M	M	RBC
SYNCHRONIZE CACHE	35h	O	O	RBC
TEST UNIT READY	00h	M	M	SPC-2 ¹
VERIFY (10)	2Fh	M	M	RBC
WRITE (10)	2Ah	M	M	RBC
WRITE BUFFER	3Bh	M	O	SPC-2 ¹

1 – See clause 6, SPC-2 Implementation Requirements for RBC Devices.
- Command Support key: M = support is mandatory; N/A = not applicable; O = support is optional.

The CONTROL byte (the last byte of the CDB) shall be set to zero.

5.2 FORMAT UNIT command

This command (see Table 3) formats the media into addressable logical blocks. This command is optional for both fixed and removable medium devices. An Initiator shall examine the state of the FORMATD bit in the MODE SENSE RBC Device Parameters page (Table 14) to determine whether the device supports this command.

Table 3 – FORMAT UNIT command

Bit Byte	7	6	5	4	3	2	1	0
0	OPERATION CODE (04h)							
1	Reserved							
2	Reserved			immed	prog-ress	percent/ time	incre-ment	
3	Reserved							
4	Reserved							
5	CONTROL = 00h							

An IMMEDIATE (IMMED) bit value of zero indicates that status shall be returned after the format operation has completed. An IMMED bit value of one indicates that this device shall return status as soon as the command descriptor block has been validated.

The PROGRESS bit indicates whether the initiator is requesting periodic format progress updates. If this bit is set to zero, no progress report shall be generated. If the PROGRESS bit is set to one then the device shall generate format progress based upon the values of the PERCENT/TIME and the INCREMENT bit. Refer to 4.3.4 for a description of the progress reporting mechanisms for the format operation.

The PERCENT/TIME bit and INCREMENT bit determine the method used to report format progress, whether in a percentage of completion, or in total elapsed time.

If the PERCENT/TIME bit is zero, format progress shall be reported in total time elapsed. If the PERCENT/TIME bit is set to one, format progress shall be reported in percentage of completion.

The INCREMENT bit specifies the granularity of progress reported. When set to zero, the device reports progress in 5 percent or 5 second increments, depending on the value of the PERCENT/TIME bit. When set to one, the device reports progress in 1 percent or 1 second increments, depending on the value of the PERCENT/TIME bit.

NOTE Initiators should set the INCREMENT bit value to zero to avoid the bus usage penalties associated with a value of one.

Format progress (when requested by setting the PROGRESS bit to one in the CDB) shall be reported with a status of CHECK CONDITION (02h), a sense key of NOT READY (02h), and an ASC/ASCQ of LOGICAL UNIT NOT READY, FORMAT IN PROGRESS (04h/04h). The SENSE DATA INFORMATION field shall contain the total number of increments (percentage complete or time in seconds) that have elapsed since command inception.

Upon successful completion of the FORMAT UNIT command, status shall be set to CHECK CONDITION (02h), the sense key to UNIT ATTENTION (06h), and the ASC/ASCQ to EVENT STATUS NOTIFICATION/MEDIA CLASS EVENT (38h/04h). The EVENT field contained within the SENSE DATA INFORMATION field shall be set to NEW MEDIA READY FOR ACCESS (02h). The initiator shall respond by issuing a MODE SENSE command followed by READ CAPACITY command.

If the FORMAT UNIT command fails, the device shall return a status of CHECK CONDITION (02h), a sense key of MEDIA ERROR (03h), an ASC/ASCQ of FORMAT COMMAND FAILED (31h/01h).

After the problem is corrected (e.g., media replaced), and the device becomes ready, the initiator shall issue a MODE SENSE command, followed by a READ CAPACITY command to determine the device's physical parameters.

While a FORMAT UNIT command is in progress, the device shall not process any command received but shall respond with the progress report information described above.

5.3 READ(10) Command

The READ(10) command (see Table 4) requests that the device transfer data to the initiator. The most recent data value written in the addressed logical block shall be returned.

Table 4 – READ (10) Command Descriptor Block

Bit Byte	7	6	5	4	3	2	1	0	
0	operation code (28h)								
1	Reserved								
2	(MSB)								
3									
4	logical block address								
5							(LSB)		
6	Reserved								
7	(MSB)								
8							transfer length		
9							(LSB)		
9	control = 00h								

The LOGICAL BLOCK ADDRESS field specifies the first logical block of the range of logical blocks that shall be read.

The TRANSFER LENGTH field specifies the number of contiguous logical blocks of data that shall be transferred. A TRANSFER LENGTH of zero indicates that no logical blocks shall be transferred. This condition shall not be considered an error. Any other value indicates the number of logical blocks that shall be transferred.

5.4 READ CAPACITY command

The READ CAPACITY command (see Table 5) provides a means for the initiator to request the current capacity of the RBC device.

Table 5 – READ CAPACITY Command Descriptor Block

Bit Byte	7	6	5	4	3	2	1	0
0	operation code (25h)							
1	Reserved							
2	Reserved							
3	Reserved							
4	Reserved							
5	Reserved							
6	Reserved							
7	Reserved							
8	Reserved							
9	control = 00h							

READ CAPACITY data (see Table 5) shall be returned to the initiator prior to sending GOOD status for the command.

Table 6 – READ CAPACITY data

Bit Byte	7	6	5	4	3	2	1	0
0	(MSB)							
1		returned logical block address						
2								
3								
4	(MSB)							
5		block length in bytes						
6								
7								

The BLOCK LENGTH IN BYTES and the RETURNED LOGICAL BLOCK ADDRESS are those of the last logical block of the media contained in the device.

If the device does not contain media, then it shall return status of CHECK CONDITION (02h), sense key of NOT READY (02h), and an ASC of LOGICAL UNIT NOT READY (04h). The ASCQ shall reflect the current state of the device/media.

5.5 START STOP UNIT command

5.5.1 General

The START STOP UNIT command (see Table 7) requests that the device enable or disable the Logical Unit for media access operations and controls certain power conditions.

Table 7 – START STOP UNIT Command Descriptor Block

Bit Byte	7	6	5	4	3	2	1	0
0	operation code (1Bh)							
1	Reserved							immed
2	Reserved							
3	Reserved							
4	power conditions				Reserved		loej	start
5	control = 00h							

An IMMEDIATE (IMMED) bit of zero indicates that status shall be returned after the operation is completed. An IMMED bit of one indicates that status shall be returned as soon as the command descriptor block has been validated.

The other fields in the START STOP UNIT command are described in the following sub-clauses

5.5.2 Power conditions

The POWER CONDITIONS field requests that the logical unit be placed into the power condition defined in Table 8. If this field contains any valid value other than zero, then the START and the LOEJ bits shall be ignored.

The POWER CONDITIONS field states are shown in Table 8. RBC device support for each state is also shown.

Table 8 – POWER CONDITIONS

Code	Support	Description
0	M	No change in power condition.
1	M	Place device in Active condition
2	M	Place device in Idle condition
3	M	Place device in Standby condition
4	-	Reserved
5	M	Place device in Sleep condition
6	-	Reserved
7	O	Device Control
8h - Fh	-	Reserved

Key: M = Command implementation is mandatory
O = Command implementation is optional

Active (condition 1): Devices in the Active state are at their highest power consumption level.

For hard disk drives, this typically means that the drive is spinning and capable of executing a media access command without a significant delay .

Idle (condition 2): Devices in the Idle state are at a lower power consumption level than when in the Active condition, but still have a significant portion of their circuitry consuming power. For hard disk drives, this typically means that the drive is spinning, but not capable of performing a media access command without a delay.

Standby (condition 3): Devices in the Standby state are at a lower power consumption level than when in the Idle condition and do not have a significant portion of their circuitry consuming power. For hard disk drives, this typically means that the drive is not spinning, but the interface is fully active. Prior to entering the Standby state the device shall ensure that logical blocks in cache have their most recent data value recorded on the physical medium.

Sleep (condition 5): Devices in the Sleep state are at a lower power consumption level than when in the Standby condition and have very little of the drive circuitry consuming power. A device reset may be required before access to the device is allowed. Prior to entering the Sleep state the device shall ensure that logical blocks in cache have their most recent data value recorded on the physical medium.

Device Control (condition 7): Devices in the Device Control state are allowed to control their own power consumption level. However, the level of Device Control is governed by the value of the POWER/PERFORMANCE field in RBC device parameter page (see sub-clause 5.9.4).

The device shall terminate any command received that requires more power consumption than allowed by the START STOP UNIT command's most recent power condition setting. Status shall be set to CHECK CONDITION (02h), the sense key to ILLEGAL REQUEST (05h), and the ASC/ASCQ to LOW POWER CONDITION ACTIVE (5Eh/00h).

It is not an error to request a device be placed into the same power consumption level in which it currently resides.

5.5.3 Control bits

A LOAD/EJECT (LOEJ) bit of zero requests that no action be taken regarding loading or ejecting the medium. A LOEJ bit of one requests that the medium shall be ejected if the START bit is zero. A LOEJ bit, when set to one, requests that the medium is to be loaded if the START bit is one.

A START bit of zero requests that the device be stopped (media is inaccessible for data transfers). A START bit of one requests the device be made ready for use. Table 9 describes the functional relationship of the START STOP UNIT control bits.

Table 9 – START STOP control bit definitions

Power Conditions	Load/Eject	START	Description
1 - 7	X	X	loej and start ignored
0	0	0	Stop the medium
0	0	1	Make medium ready
0	1	0	Unload medium
0	1	1	Load medium

5.6 SYNCHRONIZE CACHE command

The SYNCHRONIZE CACHE command (see Table 10) ensures that logical blocks in cache have their most recent data value recorded on the physical medium. If a more recent data value for a logical block exists in the cache memory than on the physical medium, then the logical block from the cache memory shall be written to the physical medium. Logical blocks are not necessarily removed from the cache memory as a result of the SYNCHRONIZE CACHE operation.

Devices that report the WCD bit set to one in the MODE SENSE RBC Device Parameters page may return status of CHECK CONDITION (02h), a sense key of ILLEGAL REQUEST (05h) and an ASC of INVALID COMMAND OPERATION CODE (20h).

Table 10 - SYNCHRONIZE CACHE Command Descriptor Block

Bit Byte	7	6	5	4	3	2	1	0
0	operation code (35h)							
1	Reserved WCD							
2	Reserved WCD							
3	Reserved WCD							
4	Reserved WCD							
5	Reserved WCD							
6	Reserved WCD							
7	Reserved WCD							
8	Reserved WCD							
9	control = 00h							

5.7 WRITE(10) command

The WRITE(10) command (see Table 11) requests that the device write data transferred from the initiator to the medium.

Table 11 – WRITE(10) Command Descriptor Block

Bit Byte	7	6	5	4	3	2	1	0
0	operation code (2Ah)							
1	Reserved				fua	Reserved		
2	(MSB)							
3	logical block address							
4								
5								
6	Reserved							
7	(MSB)							
8	transfer length							
9								
9	control = 00h							

A FORCE UNIT ACCESS (FUA) bit of zero indicates that the device may satisfy the command by accessing the cache memory if the WCD bit inRBC mode page 06h (see 5.9.4) is set to zero. For write operations, logical blocks may be transferred directly to the cache memory. GOOD status may be returned to the initiator prior to writing the logical blocks to the medium. Any error that occurs after GOOD status is returned is a deferred error.

A FUA bit of one indicates that the device shall access the media in performing the command prior to returning GOOD status. A WRITE command shall not return GOOD status until the logical blocks have actually been written on the media (i.e. the data is not write cached).

If the device supports write caching, FUA support shall be implemented. If write caching is NOT supported then the FUA bit may be ignored.

The LOGICAL BLOCK ADDRESS field specifies the first logical block of the range of logical blocks that shall be written.

The TRANSFER LENGTH field specifies the number of contiguous logical blocks of data that shall be transferred. A TRANSFER LENGTH of zero indicates that no logical blocks shall be transferred. This condition shall not be considered an error. Any other value indicates the number of logical blocks that shall be transferred.

5.8 VERIFY command

The VERIFY command (see Table 12) requests that the device verify the data written on the medium.

Table 12 – VERIFY Command Descriptor Block

Bit Byte	7	6	5	4	3	2	1	0	
0	operation code (2Fh)								
1	Reserved								
2	(MSB)								
3	logical block address								
4									
5								(LSB)	
6	Reserved								
7	(MSB)	verification length							
8								(LSB)	
9	control = 00h								

The LOGICAL BLOCK ADDRESS field specifies the starting logical block address on the device for the data to be accessed.

The VERIFICATION LENGTH field specifies the number of contiguous logical blocks of data that shall be verified. A VERIFICATION LENGTH of zero indicates that no logical blocks shall be verified. This condition shall not be considered an error. Any other value indicates the number of logical blocks that shall be verified.

The VERIFY command verifies that the data written on the media by a previous WRITE command is readable without any uncorrectable errors at the time of execution of the command. It does not guarantee the information is complete or valid

5.9 MODE parameters

5.9.1 General

This clause describes the header and page used with the MODE SELECT and MODE SENSE commands that are applicable to RBC devices.

5.9.2 Mode parameter list

The mode parameter list shown in Table 13 contains a header followed by the RBC Device Parameters page. No block descriptor is required for RBC devices.

Table 13 – Mode parameter list

Bit Byte	7	6	5	4	3	2	1	0
0 - 3	Mode parameter header							
4 - 17	RBC device parameter page							

5.9.3 Mode Parameter header

The mode parameter header is described in SPC-2. For RBC devices the MEDIUM TYPE, DEVICE-SPECIFIC PARAMETER and BLOCK DESCRIPTOR LENGTH fields shall contain zero.

5.9.4 RBC device parameter page

The RBC Device Parameters page (see Table 14) is intended to provide general configuration information and to allow modification of that configuration, when permitted by the device. An initiator may attempt to change any or all parameters contained in the page. No error status shall be returned for parameters that are not changeable.

The initiator may issue a MODE SENSE command for the same page in order to determine which parameters have changed.

Table 14 – RBC Device Parameters page format

Bit Byte	7	6	5	4	3	2	1	0
0	PS = 1	rsvd	page code (06h)					
1	page length (0Bh)							
2	Reserved							wcd
3	(MSB)	logical block size						(LSB)
4								
5	(MSB)	number of logical blocks						(LSB)
6								
7								
8								
9								
10	power/performance							
11	Reserved				readd	writed	formatd	lockd
12	Reserved							

A WRITE CACHE DISABLE (WCD) bit of zero specifies that the device may return GOOD status for a WRITE command after successfully receiving the data and prior to having successfully written it to the medium. A WCD bit of one specifies that the device shall return GOOD status for a WRITE command after successfully writing all of the data to the medium.

Devices that cannot physically lock the media or are unable to prevent media removal (e.g., floppy drives, PCMCIA drives, Flash cards, etc.) shall ignore the WCD bit and shall report WCD equal to 1 in Mode Sense information.

The LOGICAL BLOCK SIZE field indicates the number of user data bytes contained in a logical block.

The NUMBER OF LOGICAL BLOCKS field indicates the number of logical blocks contained in the user data area.

Setting the POWER CONDITIONS field of the START STOP UNIT command to Device Control (07h) enables the POWER/PERFORMANCE field.

The POWER/PERFORMANCE field specifies the POWER/PERFORMANCE management level. Higher values permit the device to give more emphasis to performance than power conservation. A value of FFh causes the drive to provide the highest performance possible, not affected by power conservation. A value of 00h causes the drive to provide the highest power conservation, regardless of its effect on performance.

Changes in the level of power and performance for specific values of the POWER/PERFORMANCE field are vendor specific

A READ DISABLED (READD) bit of zero indicates that the media may be read by an initiator. A READD bit of one indicates that an initiator cannot read the media.

A WRITE DISABLED (WRITED) bit of zero indicates that the media may be written. A WRITED bit of one indicates that an initiator cannot write the media.

A FORMAT DISABLED (FORMATD) bit of zero indicates that the media may be formatted. A FORMATD bit of one indicates that an initiator cannot format the media. The FORMATD bit shall not be set to zero if the WRITED bit is set to one.

A LOCK DISABLED (LOCKD) bit of zero indicates that the media may be locked by the PREVENT/ALLOW MEDIUM REMOVAL command. A LOCKD bit, when set to one, indicates that the media cannot be locked by the PREVENT/ALLOW MEDIUM REMOVAL command. If the RMB bit in the standard INQUIRY command data is not set to one, then the LOCKD bit shall be set to one.

6 SPC-2 Implementation Requirements For RBC Devices

6.1 General

RBC devices require several commands defined in SPC-2 to function in a system. Bit and field exceptions contained in those commands listed in Table 15 are described in the following clauses.

Table 15 – Required SPC-2 commands

Command name	Opcode	Command Support		Reference
		Fixed	Removable	
INQUIRY	12h	M	M	SPC-2
MODE SELECT(6)	15h	M	M	SPC-2
MODE SENSE(6)	1Ah	M	M	SPC-2
PREVENT/ALLOW MEDIUM REMOVAL	1Eh	N/A	M	SPC-2
REQUEST SENSE	03h	O	O	SPC-2
TEST UNIT READY	00h	M	M	SPC-2
WRITE BUFFER	3Bh	M	O	SPC-2

Command Support key: M = support is mandatory; N/A = not applicable; O = support is optional.

6.2 INQUIRY command

6.2.1 General

The standard INQUIRY data format is reproduced in Table 16. Several INQUIRY data bits and fields are restricted for RBC compatibility. Only the restricted fields and their values are shown. Refer to SPC-2 for descriptions of fields and bits not shown.

Table 16 – Standard Inquiry data format

Bit Byte	7	6	5	4	3	2	1	0
0	peripheral device type = 0E h							
1	rmb							
2								
3	aerc		naca=0					
4								
5								
6								
7	reladr=0				linked=0			
8								
9								
-								
n								

RBC devices are identified by a PERIPHERAL DEVICE TYPE field set to 0E h.

A REMOVABLE MEDIUM BIT (RMB) of zero indicates that the medium is not removable. A RMB bit of one indicates that the medium is removable.

If the transport protocol provides a mechanism for asynchronous event reporting, RBC devices shall support the function and indicate that support by setting the ASYNCHRONOUS EVENT REPORTING CAPABILITY (AERC) bit to one.

RBC devices shall report sense data using the AUTOSENSE method if the transport protocol supports this function. RBC devices shall clear all tasks as the result of any device error.

RBC devices shall not support Auto Contingent Allegiance and ignore the Normal ACA bit in the CDB Control byte. Therefore, RBC devices shall return a zero in the Normal ACA bit in Inquiry data (shown as NACA in Table 16).

The RELADR bit shall be set to zero. Relative Addressing is not supported by RBC devices.

The LINKED bit shall be set to zero. LINKED commands are not supported by RBC devices.

Consult SPC-2 for the meaning and usage of bits and fields in the INQUIRY command that are not defined by this standard. Logical unit support for these other bits and fields may be mandatory or optional, as specified by SPC-2.

6.2.2 INQUIRY vital product data pages

6.2.2.1 General

This clause describes the vital product data pages that are mandatory for RBC devices. This standard defines the required pages but not the page content.

6.2.2.2 Unit serial number page

The Unit Serial Number page, 80h, shall be supported by RBC devices.

6.2.2.3 Device Identification page

The Vital Product Data Device Identification page, 83h, shall be supported by RBC devices.

6.3 MODE SELECT(6) command

6.3.1 General

The MODE SELECT(6) command (see Table 17) provides a means for an initiator to specify device parameters to a RBC device. RBC devices shall also implement the MODE SENSE(6) command.

Table 17 – MODE SELECT(6) Command Descriptor Block

Bit	7	6	5	4	3	2	1	0
Byte								
0	operation code (15h)							
1				PF = 1				SP
2	Reserved							
3	Reserved							
4	parameter list length							
5	control = 00h							

The PAGE FORMAT (PF) bit shall be set to one.

The PARAMETER LIST LENGTH field specifies the length in bytes of the mode parameter list. A parameter length of zero shall not be considered an error.

An initiator may attempt to change any or all parameters contained in a mode page. The device shall ignore non-changeable parameters in the MODE SELECT parameter data. This shall not be considered an error.

The initiator may issue a MODE SENSE command for the same page in order to determine which parameters have changed.

6.3.2 SAVE PAGES (SP) bit support

For non-removable medium devices the SAVE PAGES (SP) bit shall be set to one. This indicates that the device shall perform the specified MODE SELECT operation and shall save, to a non-volatile vendor-specific location, all the changeable pages, including any sent with the command.

For removable medium devices support of the SP bit is optional. Such devices may be unable to save changeable information to a non-volatile medium. Therefore, if the SP bit is set to one, removable medium devices may return a status of CHECK CONDITION (02h), a sense key of ILLEGAL REQUEST (05h) and an ASC of INVALID FIELD IN CDB (24h).

6.4 MODE SENSE(6) command

The MODE SENSE(6) command (see Table 18) provides a means for an RBC device to report device parameters to an initiator. It is a complementary command to the MODE SELECT(6) command.

Table 18 – MODE SENSE(6) Command Descriptor Block

Bit Byte	7	6	5	4	3	2	1	0
0	operation code (1Ah)							
1					dbd = 1			
2	pc		page code					
3	Reserved							
4	allocation length (LSB)							
5	control = 00h							

The DISABLE BLOCK DESCRIPTORS (DBD) bit shall be set to one.

The PAGE CONTROL (PC) field defines the type of mode parameter values to be returned in the mode page.

The device shall respond to PC values in the following manner:

- a) If Current values are requested, report the Current values of the mode parameters established by the last MODE SELECT command. If the device implements no distinction between current and saved parameters, then it shall report identical values in response to a PC of either 00b or 11b. If Saved or Current values are not available, report Default values.
- b) If Default values are requested, report the Default values;
- c) If Saved values are requested, report valid restored mode parameters, or restore the mode parameters and report them.

6.5 PREVENT ALLOW MEDIUM REMOVAL

RBC devices shall support the PREVENT ALLOW MEDIUM REMOVAL command if the REMOVABLE MEDIUM BIT (RMB) bit is set to one in the INQUIRY command standard data.

6.6 REQUEST SENSE command

RBC devices shall support the REQUEST SENSE command if AUTOSENSE Data is not provided or if either Asynchronous Event Notification or the GET EVENT STATUS NOTIFICATION command is not supported.

If the REQUEST SENSE command is supported it shall be implemented as described in the SPC-2 specification.

6.7 TEST UNIT READY command

RBC devices shall report information exceptions via the unit attention condition (with the associated asynchronous event notification, if enabled) or the TEST UNIT READY response. The TEST UNIT READY status response shall include information exception status only after a threshold has been exceeded. Once the associated asynchronous event notification has been successfully sent to the initiator the device shall clear the information exception status from the TEST UNIT READY response. The required Sense Key is RECOVERED ERROR (01h), and the ASC is FAILURE PREDICTION THRESHOLD EXCEEDED (5Dh). The ASCQ values are described in Table 19.

Table 19 – FAILURE PREDICTION ASCQ XY definitions

ASCQ X	Description	ASCQ Y	Description
0h	Defined by SPC-2	0h	General hard drive failure
1h	Hardware impending failure	1h	Drive error threshold exceeding limits
2h	Controller impending failure	2h	Data error rate exceeding limits
3h	Data Channel impending failure	3h	Seek error rate exceeding limits
4h	Servo impending failure	4h	LBA reassignment exceeding limits
5h	Spindle impending failure	5h	Access times exceeding limits
6h	Firmware impending failure	6h	Start Unit times exceeding limits
7h	Reserved	7h	Channel parametrics indicate impending failure
8h	Vendor Specific in SPC-2	8h	Controller detected impending failure
9h	Vendor Specific in SPC-2	9h	Throughput performance
Ah	Vendor Specific in SPC-2	Ah	Seek time performance
Bh	Vendor Specific in SPC-2	Bh	Spin-up retry count
Ch	Vendor Specific in SPC-2	Ch	Drive calibration retry count
Dh	Vendor Specific in SPC-2	Dh	Reserved
Eh	Vendor Specific in SPC-2	Eh	Reserved
Fh	Refer to SPC-2	Fh	Reserved

6.8 WRITE BUFFER Command

6.8.1 General

The WRITE BUFFER command (see Table 20) is used to download and save microcode. RBC devices are required to support Modes 101b and 111b. Support for all other modes is optional.

Table 20 – WRITE BUFFER Command Descriptor Block

Bit Byte	7	6	5	4	3	2	1	0	
0	operation code (3Bh)								
1	Reserved					mode			
2	Reserved								
3	(MSB)								
4	buffer offset								
5								(LSB)	
6	(MSB)								
7	parameter list length								
8								(LSB)	
9	control = 00h								

6.8.2 Download Microcode and save mode (101b)

In this mode, vendor-specific Microcode or control information shall be transferred to the device and, if the WRITE BUFFER command is completed successfully, shall also be saved in a non-volatile memory space (semiconductor, disk, or other). The downloaded code shall then be effective after each power-cycle and reset until it is supplanted in another download Microcode and save operation. When the WRITE BUFFER command has completed successfully, the device shall generate a unit attention condition. If asynchronous event notification is enabled, all initiators except the one that issued the WRITE BUFFER command shall be notified of the unit attention condition. The device shall set the sense key to UNIT ATTENTION (02h) and the ASC/ASCQ to MICROCODE HAS BEEN CHANGED (3Fh / 01h).

The PARAMETER LIST LENGTH specifies the maximum number of bytes that shall be transferred from the initiator to the device.

If the logical unit cannot accept this command because of a device condition, the device shall terminate the command and return a status of CHECK CONDITION (02h), a sense key of ILLEGAL REQUEST (05h) and an ASC of COMMAND SEQUENCE ERROR (2Ch).

6.8.3 Download Microcode with offsets and save mode (111b)

In this mode, the initiator may split the transfer of the vendor-specific microcode or control information over two or more WRITE BUFFER commands. If the logical unit cannot accept this command because of a device condition, the device shall terminate the command and return a status of CHECK CONDITION (02h), a sense key of ILLEGAL REQUEST (05h) and an ASC of COMMAND SEQUENCE ERROR (2Ch).

Refer to SPC-2 for a complete description of this mode.

7 Asynchronous Event Notification for RBC devices

7.1 General

RBC devices shall notify initiators of the ability to support asynchronous event notification by setting the ASYNCHRONOUS EVENT REPORTING CAPABILITY (AERC) bit to one in the standard data format of the INQUIRY command (see SPC-2).

Table 21 describes conditions that may be communicated to an initiator as an asynchronous event.

Table 21 - Asynchronous Event conditions

Sense key	ASC	Description
01h	5Dh	RECOVERED ERROR. FAILURE PREDICTION THRESHOLD EXCEEDED.
02h	04h	LOGICAL UNIT NOT READY (reported only on transition or at power on).
03h	nnh	MEDIUM ERROR. Multiple causes.
06h	38h	Unit Attention. Event Status Notification.
06h	5Eh	Unit Attention. Power condition Change Notification.
06h	28h	Unit Attention. Not Ready to Ready transition. Medium may have changed.
06h	29h	Unit Attention. Power on reset, bus reset, etc.
– This list is for illustration purposes. It is not intended to be a complete list.		

7.2 Unit Attention

A unit attention condition may be reported via asynchronous event notification. Logical units may queue unit attention conditions; more than one unit attention condition may exist at the same time. Refer to Table 21 for a description of unit attention conditions that may be reported via asynchronous event notification.

7.2.1 Power condition change notification

RBC devices shall notify an initiator of the intent to change power conditions via asynchronous event notification. The status value shall be set to CHECK CONDITION (02h), the sense key to UNIT ATTENTION (06h), and the ASC to POWER CONDITION CHANGE NOTIFICATION (5Eh). The ASCQ shall be set to the value of the new power condition plus 40h as shown in Table 22.

Table 22 – Power condition sense code and qualifier values

ASC	ASCQ	Description
5E h	41h	POWER CONDITION CHANGE TO ACTIVE
5E h	42h	POWER CONDITION CHANGE TO IDLE
5E h	43h	POWER CONDITION CHANGE TO STANDBY
5E h	45h	POWER CONDITION CHANGE TO SLEEP
5E h	47h	POWER CONDITION CHANGE TO DEVICE CONTROL

An initiator shall respond with a START STOP UNIT command within 8 seconds, if it intends to manage the power transition. If the initiator does not respond within 8 seconds, the device may transition to a new power condition. If the initiator responds with a START

STOP UNIT command within 8 seconds, and sets the power condition value equal-to or greater-than the current value, the device shall not transition to a lower power condition.

7.3 Deferred errors

Deferred errors shall also be reported via asynchronous event notification. Deferred errors may be produced as a result of cached data management or support of the Immediate function in commands such as START STOP UNIT or FORMAT.

7.4 Information exception condition notification

RBC devices shall notify the initiator when an information exception condition exists via asynchronous event notification. The status field shall be set to CHECK CONDITION (02h), the sense key to RECOVERED ERROR (01h), the ASC to FAILURE PREDICTION THRESHOLD EXCEEDED (5Dh), and the ASCQ to the failure prediction threshold descriptor value. Refer to Table 19 for failure prediction ASCQ values.

7.5 Event status notification

7.5.1 General

Through the use of asynchronous event notification, RBC devices may report asynchronous events the moment that they occur.

If the initiator does not support asynchronous event notification, alternative methods shall be used to determine the state of the device/media combination. Refer to the GET EVENT STATUS NOTIFICATION command for a description of those alternative methods.

7.5.2 Event Status sense information

The following sense data shall be used for the event status notification, unit attention condition. The status value shall be set to CHECK CONDITION (02h). The SENSE KEY shall be set to UNIT ATTENTION (06h). The ASC shall be set to EVENT STATUS NOTIFICATION (38h). The ASCQ shall be set to the appropriate value shown in Table 23.

Table 23 – Event status ASCQ values

ASCQ	Name	Description
02h	POWER MANAGEMENT CLASS EVENT	Indicates that a Power Management Class event has occurred or is impending.
04h	MEDIA CLASS EVENT	Indicates that a Media Class event has occurred.
06h	DEVICE BUSY CLASS EVENT	Indicates that a Device Busy Class event has occurred.

For each of the sense key, ASC, and ASCQ values above, the contents of the sense data INFORMATION field further describe the event status. The general format of the sense data INFORMATION field is shown in Table 24.

Table 24 - Event Status INFORMATION field format

Bit Byte	7	6	5	4	3	2	1	0
0	event							
1	status							
2	event specific							
3	event specific							

The following clauses provide specific sense data INFORMATION field definitions for each ASCQ value described in Table 23.

7.5.3 POWER MANAGEMENT CLASS INFORMATION field

Table 25 displays the INFORMATION field format for POWER MANAGEMENT CLASS EVENTS.

Table 25 - POWER MANAGEMENT CLASS INFORMATION field format

Bit Byte	7	6	5	4	3	2	1	0
0	event							
1	status							
2	reserved							
3	reserved							

Table 26 describes the EVENT field values associated with POWER MANAGEMENT CLASS EVENTS.

Table 26 - POWER MANAGEMENT CLASS EVENT field

event field	Description
00h	No power condition change.
01h	The device successfully changed to the specified power condition.
02h	The device failed to enter the last commanded power condition and is still operating at the state specified in the Power Status field.
03h - FFh	Reserved.

Table 27 describes the STATUS field values for POWER MANAGEMENT CLASS events. The state names and values match those specified in the START STOP UNIT command, POWER CONDITIONS field.

Table 27 - POWER MANAGEMENT CLASS STATUS field

status field	Description
00h	Reserved.
01h	The device is in the Active state.
02h	The device is in the Idle state.
03h	The device is in the Standby state.
04h	Reserved.
05h	Not Applicable (Sleep state).
06h	Reserved.
07h	The device is in the Device Control state.
08h - FFh	Reserved.

7.5.4 MEDIA CLASS EVENT INFORMATION field

Table 28 displays the INFORMATION field format for MEDIA CLASS events.

Table 28 - MEDIA CLASS INFORMATION field format

Bit Byte	7	6	5	4	3	2	1	0
0	event							
1	reserved						media present	door or tray open
2	start slot							
3	end slot							

Table 29 describes the EVENT field values associated with MEDIA CLASS events.

Table 29– MEDIA CLASS EVENT field

event field	Description
00h	Media status is unchanged.
01h	Eject request. The user has issued a request to eject the slot or media.
02h	The specified slot has received new media and the media is ready to be accessed.
03h	Media Removal. The media has been removed from the specified slot and the device is unable to access the media without user intervention.
04h - FFh	Reserved.

The DOOR OR TRAY OPEN bit indicates the mechanical position of the device’s door or tray. A DOOR OR TRAY OPEN value of one indicates that the door or tray is open. A value of zero indicates that the door or tray is closed.

The MEDIA PRESENT bit indicates whether media is installed in the device. A value of one indicates that media is present in the device. A value of zero indicates that no media is present. The MEDIA PRESENT bit is reported independently from the DOOR OR TRAY OPEN bit. If the device cannot report the media state while the door or tray is open, this bit shall be set to zero when the DOOR OR TRAY OPEN bit is zero.

The START SLOT field defines the first slot of a multiple slot device that the media status notification applies to. For devices that do not support multiple slots, this field shall be reserved.

The END SLOT field defines the last slot of a multiple slot device that the media status notification applies to. For devices that do not support multiple slots, this field shall be reserved.

7.5.5 DEVICE BUSY CLASS Event Information Values

Table 30 displays the INFORMATION field format for DEVICE BUSY CLASS events.

Table 30 – DEVICE BUSY CLASS INFORMATION field format

Bit Byte	7	6	5	4	3	2	1	0
0	event							
1	status							
2	time							
3								

Table 31 describes the EVENT field values associated with DEVICE BUSY CLASS events.

Table 31 – DEVICE BUSY CLASS EVENT field

event field	Description
00h	No event is available.
01h	A time-out has occurred.
02h	Immediate command progress indication
02h - FFh	Reserved.

Table 32 describes the STATUS field values for DEVICE BUSY CLASS events.

Table 32 - DEVICE BUSY CLASS STATUS field

Status field	Description
00h	No event. The device is ready to accept commands.
01h	The device is in the process of waking up from a lower power condition.
02h	The device is in the process of completing an earlier command.
03h	The device is in the process of completing a deferred operation, such as a write.
04h - FFh	Reserved.

For DEVICE BUSY class events with an EVENT field value of 02h, the TIME field is the percent completion of an immediate command. For EVENT field values other than 02h, the TIME field is the predicted amount of time remaining for the device to become not busy, in units of 100 ms.

7.5.6 Event status retention

A unit attention condition, generated by an asynchronous event, shall be retained by a device if a bus reset takes place after the event has occurred but prior to the unit attention information transfer to the initiator. Once the unit attention condition is successfully

communicated to the initiator, the device shall discard the retained event status information.

7.5.7 Removable Medium Device Initial Response

The following sequence shall occur at power on of removable devices:

- When ready, the device shall generate an event status notification. The device shall set the status value to CHECK CONDITION (02h), the sense key to UNIT ATTENTION (06h), and the ASC/ASCQ to EVENT STATUS NOTIFICATION / MEDIA CLASS EVENT (38h/04h). The event field shall be set to NEW MEDIA READY FOR ACCESS (02h).
- The initiator shall issue a MODE SENSE command followed by a READ CAPACITY command.
- The initiator may issue a START STOP UNIT command with POWER CONDITIONS field values of 1, 2 or 3. If this command is not issued, the device shall assume the Standby state (POWER CONDITIONS = 3).
- If a START STOP UNIT command is issued, the device shall return event status notification. The status value shall be set to CHECK CONDITION (02h), the sense key to UNIT ATTENTION (06h), and the ASC/ASCQ to EVENT STATUS NOTIFICATION/POWER MANAGEMENT CLASS EVENT (38h/02h). The EVENT field of the INFORMATION data shall be set to DEVICE SUCCESSFULLY CHANGED POWER CONDITIONS (01h).

Annex A (normative)

RBC device implementation requirements for SBP-2

A.1 SBP-2 Definitions

A.1.1

command block

Space reserved within an ORB to describe a command intended for a logical unit that controls device functions or the transfer of data to or from device medium.

A.1.2

logical unit

part of the unit architecture that is an instance of a device model, e.g., mass storage, CD-ROM or printer. In devices that implement one or more logical units, the device type of the logical units may differ.

A.1.3

Login

process by which an initiator obtains access to a set of device fetch agents. The device fetch agents and their control and status registers provide a mechanism for an initiator to signal ORB's to the device.

A.1.4

Quadlet

four bytes, or 32 bits, of data.

A.1.5

Register

term used to describe quadlet aligned addresses that may be read or written by Serial Bus transactions. In the context of this standard, the use of the term register does not imply a specific hardware implementation. For example, the behavior of registers may be emulated by a processor.

A.1.6

sense code

field in the SBP-2 status block (see A.6). Equivalent to the additional sense code field in the REQUEST SENSE command sense data.

A.1.7

sense code qualifier

field in the SBP-2 status block (see A.6). Equivalent to the additional sense code field in the REQUEST SENSE command sense data.

A.1.8

sense key

field in the SBP-2 status block (see A.6). Equivalent to the sense key field in the REQUEST SENSE command sense data

A.1.9

status block

data structure written to system memory by a device when an operation request block has been completed.

A.1.10**system memory**

portions of any node's memory that are directly addressable by a Serial Bus address and which accepts, at a minimum, quadlet read and write access. Computers are the most common example of nodes that make system memory addressable from Serial Bus, but any node, including those usually thought of as peripheral devices, may have system memory.

A.1.11**Transaction**

exchange between a requester and a responder that consists of a request and a response subaction. The request subaction transmits a Serial Bus transaction such as quadlet read, block write or lock, from the requesting node to the node intended to respond. Some Serial Bus commands include data as well as transaction codes. The response subaction returns completion status and sometimes data from the responding node to the requesting node.

A.1.12**Unit**

component of a Serial Bus node that provides processing, memory, I/O or some other functionality. Once the node is initialized, the unit provides a CSR interface that is typically accessed by device driver software at an initiator. A node may have multiple units, which normally operate independently of each other. Within this standard, a unit is equivalent to a device.

A.1.13**unit architecture**

specification of the interface to and the services provided by a unit implemented within a Serial Bus node.

A.1.14**unit attention**

state that a logical unit maintains while it has unsolicited status information to report to one or more logged-in initiators. A unit attention condition shall be created as described elsewhere in this standard or in the applicable command set- and device-dependent documents.

A.2 Acronyms

The following are abbreviations that are used in this standard:

CSR	Control and Status Register
EUI-64	Extended Unique Identifier, 64-bits (ANSI/IEEE 1394-1995)
ORB	Operation request block (see SBP-2)
SBP-2	Serial Bus Protocol 2

A.3 SBP-2 storage model**A.3.1 General**

The SBP-2 Storage Model describes general characteristics and functions of RBC devices when implemented using SBP-2. It is intended to provide design information and lead to a better understanding of RBC device functionality.

A.3.2 Model configuration

A.3.2.1 General

This configuration is used only as an example of a common implementation. The following assumptions are made for this model configuration.

- The device supports a single logical unit.
- The device does not support multiple initiators.
- The device does not support Isochronous data transfers.

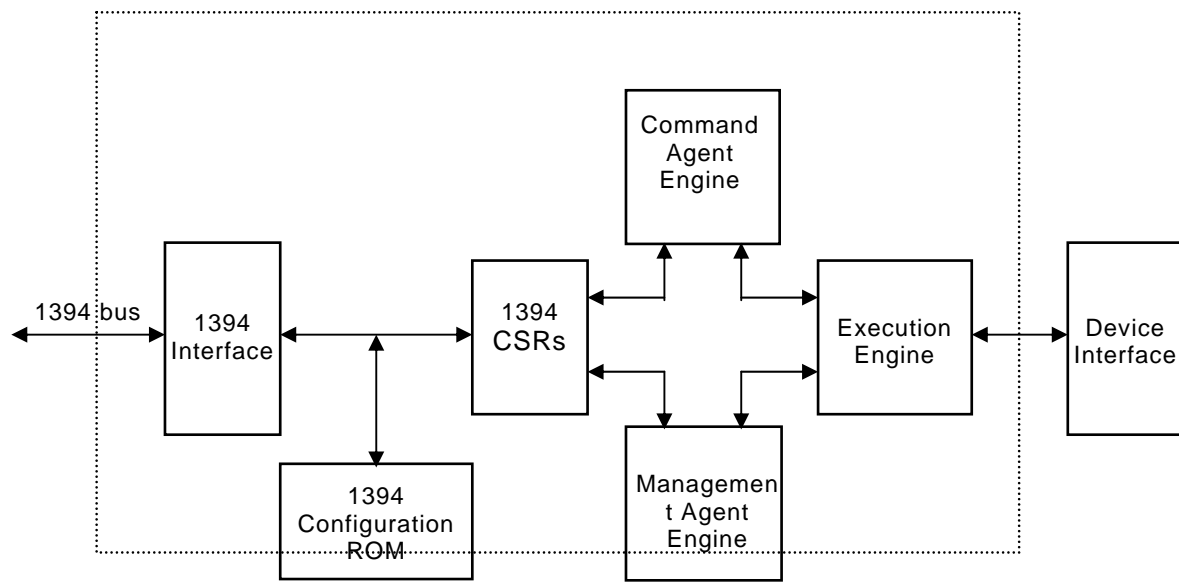

Figure A.1 – Mass storage interface block diagram

A.3.2.2 Model operation

The block diagram in Figure A.1 indicates the functional blocks contained in an RBC device that supports SBP-2. This section describes the function of those blocks when processing a list of ORBs. The ORBs contain READ commands in this example.

After power-on or bus reset, the COMMAND_AGENT and MANAGEMENT_AGENT engines are in the Reset State.

The initiator reads the RBC device's Configuration ROM data in order to determine its 1394 capabilities, SBP-2 capabilities, EUI-64 value, command set identifiers, software versions, and MANAGEMENT_AGENT CSR address.

The initiator performs a Login operation prior to any request to the RBC device. To perform a Login, the initiator writes its Login ORB address to the MANAGEMENT_AGENT register. The Login ORB shall contain either the current or master password for the Login to be successful. The RBC device returns the Login response to the bus address specified in the Login ORB. One field of the Login response contains the COMMAND_AGENT's CSR base address.

Prior to initiating command transfers, the initiator builds a list of COMMAND_BLOCK ORBs in system memory. The list may be as short as one ORB, but this example assumes a list length of more than one. The last ORB in the list contains a NULL NEXT_ORB pointer that indicates the end of the list to the RBC device's COMMAND_AGENT fetch engine.

To transition the COMMAND_AGENT state from Reset to Active the initiator writes the offset of the first ORB in the ORB list to the RBC device's ORB_POINTER CSR address. This allows the COMMAND_AGENT fetch engine to begin fetching ORBs from initiator memory. If the initiator writes to the Doorbell CSR, the RBC device shall ignore the Doorbell at this time.

The RBC device fetches ORBs until its ORB space is full or until an ORB containing a NULL NEXT_ORB pointer is fetched. Fetched ORBs are routed to the Execution engine. The Execution engine may reorder the commands contained in the ORBs for best performance.

As each READ command is executed the RBC device transfers READ data to the initiator's memory space via block write requests.

Following the data transfer portion of each command the RBC device writes a Status_Block to the initiator's Status_FIFO address. The Status_FIFO address for Command Block ORBs is contained in the Login ORB. The status block contains SBP-2 specific command information, such as the ORB_offset of the Command_Block ORB associated with this status, as well as general sense information.

: ORBs contain a NOTIFY bit that is to be set to one if a Status_Block is to be written to initiator memory after every ORB is executed or set to zero if a Status_Block is to be written only after ORB execution encounters an error. This bit is advisory only. RBC devices shall return a Status_Block for all ORBs executed.

If an ORB containing a Null Next_ORB pointer is fetched the Execution engine completes all fetched commands, including the one in the just fetched ORB, before the Command_Agent transitions to the Suspended state.

If additional commands are to be executed, the initiator creates a new list of Command_Block ORBs, changes the Next_ORB pointer in the last ORB of the old list from NULL to the offset of the first ORB in the new list; then writes to the RBC device's Doorbell CSR address. This transitions the Command_Agent to the Active state.

The RBC device fetches the new Next_ORB pointer value from the last ORB of the old list and begins fetching ORBS from the new list at that offset.

If the Command_Agent fetch engine has not reached the ORB containing a Null Next_ORB pointer (and is still in the Active state), the RBC device ignores any writes to the Doorbell CSR address.

This sequence may continue until the RBC device is reset, power is removed, or an error occurs.

A.3.3 Reconnect/Power reset support

RBC devices shall support the Reconnect management function following a bus reset, as described in SBP-2. However, in the case that a Reconnect request occurs following a power reset, RBC devices shall perform as follows:

- a) Following a power reset, any previous login information shall be discarded and the device shall transition to the Reset State.
- b) If an initiator sends a Reconnect ORB to the device, the device shall return status with RESP set to 0, REQUEST COMPLETE, and SBP_status set to Ah, LOGIN ID NOT RECOGNIZED.

A.4 Configuration ROM support

A.4.1 General

Although most Configuration ROM entries are generic, several contain information that is specific to each device type. Hard disk drive specific Configuration ROM information is defined in this section.

A.4.2 Unit Directory - Command_Set_Spec_ID

The COMMAND_SET_SPEC_ID entry (key - 38h) is an immediate entry that specifies the organization responsible for the command set definition for the device.

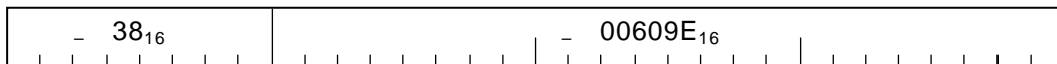

A.4.3 Unit Directory - Command_Set

The COMMAND_SET entry (key - 39h) is an immediate entry that, in combination with the COMMAND_SET_SPEC_ID entry, specifies the command set implemented by the unit.



A.4.4 Unit Directory - Logical_Unit_Number

LOGICAL_UNIT_NUMBER entry (key - 14h) is an immediate entry that specifies the device type and the logical unit number of a logical unit supported by the drive. The format of this entry is defined in SBP-2 and duplicated here with additional field information for hard disk drives.

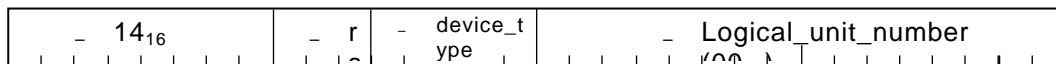

The DEVICE_TYPE field indicates the peripheral device type implemented by the logical unit. The value defined for RBC devices is 0Eh.

The LOGICAL_UNIT_NUMBER field indicates the value of a logical unit supported by the drive. For hard disk drives that support one logical unit, the value is 0000h.

A.5 Security support

RBC Devices shall implement security against unauthorized media access as defined in the security annex of SBP-2.

The master password, referenced in SBP-2, is contained in the INQUIRY command, Vital Product Data, page 80h. Following a successful Login operation, the initiator shall request that the device perform the INQUIRY command, in order to obtain the device's serial number.

Bibliography

ISO/IEC14776-412: 2nd ed.. *Information technology - Small Computer System Interface (SCSI) - Part 412: SCSI, Architecture Model-2 (SAM -2)* [T10 Project 1157D, SCSI Architecture Model 2 (SAM-2)²⁾]

ISO/IEC14776-362: 2nd ed.. *Information technology - Small Computer System Interface (SCSI) - Part 362: Multimedia commands-2 (MMC-2)* (under consideration) [T10 Project 1228D, SCSI-3 Multimedia Commands 2 (MMC-2)²⁾]