

Date: 9/2/08

To: T10 Committee (SCSI)

From: George Penokie (LSI)

Subject: SAS-2: Making 07-193 into an Annex

1 Overview

This is the re-creation of 07-193r1 putting it into a form that can be placed into the SAS-2 standard as an informative annex.

2 SAS-2 changes

2.1 Other references

[Touchstone® file format](#)

NOTE 1 - [Touchstone®](#) is a registered trademark of Agilent Corporation. The [Touchstone](#) file format is part of the [I/O Buffer Information Specification \(IBIS\) project \(http://www.eda.org/ibis/\)](#) within the EIA organization. For more information on the [Touchstone](#) file format see http://www.eda.org/pub/ibis/connector/touchstone_spec11.pdf.

3 Definitions, symbols, abbreviations, keywords, and conventions

3.1 Definitions

3.1.1 [etch: Printed circuit board copper conductor path.](#)

3.2 Transmitter and receiver device electrical characteristics

...

3.2.1 Test loads

...

3.2.1.1 Reference transmitter test load

The reference transmitter test load is a 10 m Mini SAS 4x cable assembly.

The reference transmitter test load is used along with the reference receiver device (see 5.3.7.4.3) for simulation of 6 Gbps transmitter device compliance. The specific simulation program used (e.g., StatEye from <http://www.stateye.org>) is not specified by this standard.

[The following Touchstone file containing the S-parameters of the reference transmitter test load is included:](#)

- a) [SAS2_transmittertestload.s4p.](#)

~~See annex A.1 for [A](#) an S-parameter model of the reference transmitter test load. [is included with this standard. This model includes reference transmitter device \(see 5.3.6.5.4\) etch, the reference transmitter test load, and reference receiver device \(see 5.3.7.4.3\) etch. The following files are included:](#)~~

- ~~b) [07-193r1_SAS2_transmittertestload.pdf](#) describes how the model was created, including the specific etch configuration; and~~
- ~~c) [07-193r1_SAS2_transmittertestload.s4p](#) is a Touchstone® file containing the S-parameters of the reference transmitter test load.~~

NOTE 2 - ~~[Touchstone®](#) is a registered trademark of Agilent Corporation.~~

Figure 1 shows the physical model used to measure the reference transmitter test load. The etches between the transmission points and probe points may be included in an S-parameter measurement of a TxRx connection. Although these etches add extra loss to the TxRx connection, they are considered to be an acceptable amount of loss for simulation purposes when restricted to a configuration similar to the reference transmitter test load.

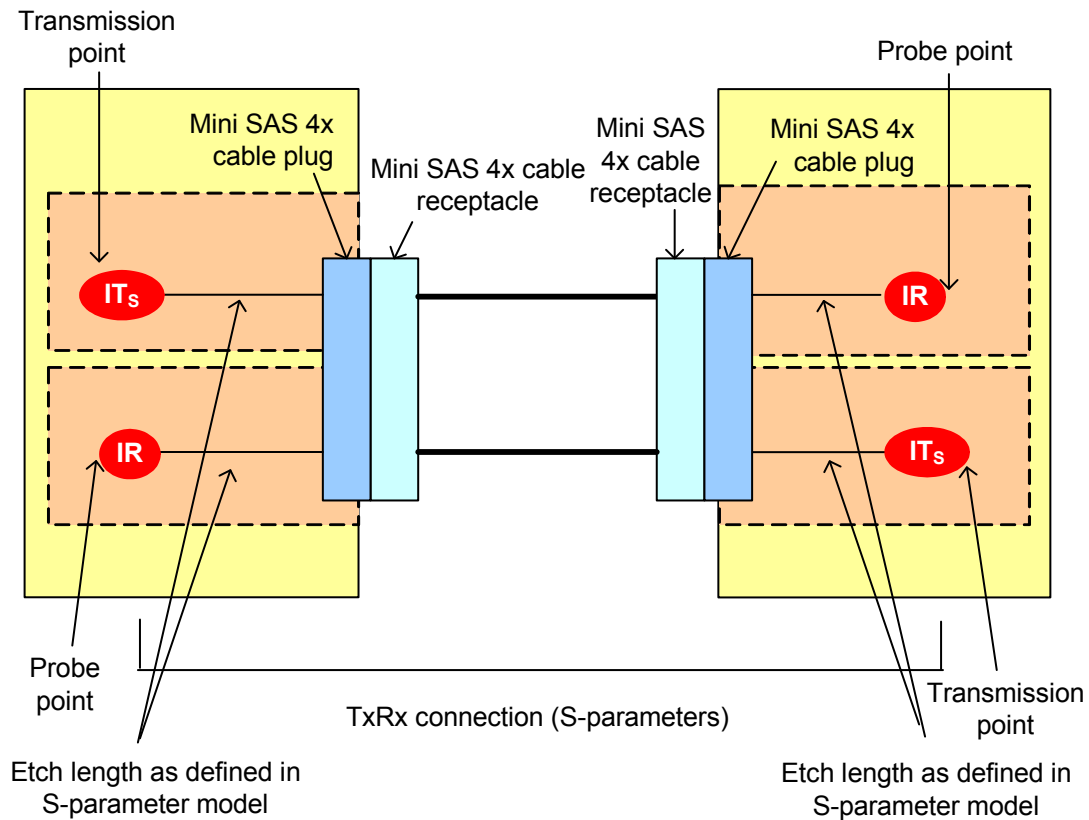

Figure 1 — Reference transmitter test load physical characterization

Annex A (informative)

S-parameter model

A.1 S-parameter model of the reference transmitter test load

A.1.1 S-parameter model of the reference transmitter test load overview

The S-parameter model of the reference transmitter test load consists of:

- a) an etch length of 50 mm with an etch width of 178 μm between the IT_s (see 5.3.6.5.4) and the Mini SAS 4x cable plug (see figure A.1) in 4000-13 material environment;
- b) 10 m Mini SAS 4x cable assembly; and
- c) an etch length of 50 mm with an etch width of 178 μm between the IR (see 5.3.7.4.3) and the Mini SAS 4x cable plug (see figure A.1) in 4000-13 material environment.

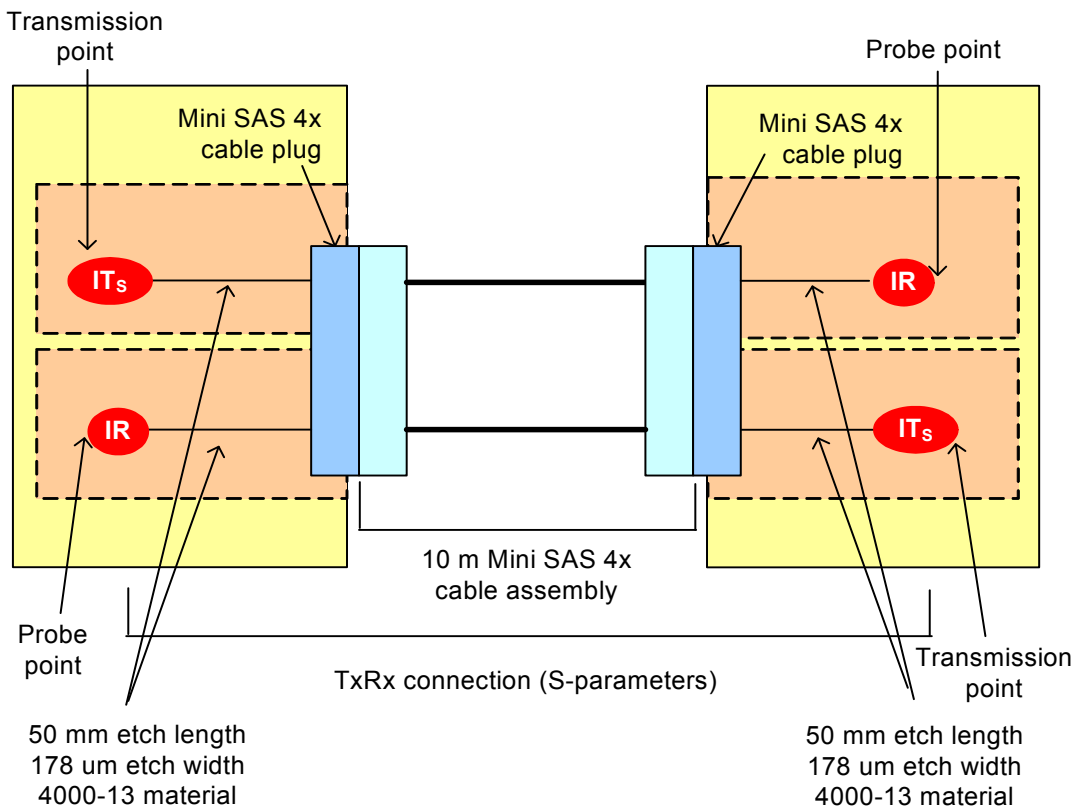

Figure A.1 — S-parameter model of the reference transmitter test load

A.1.2 Equipment setup for generating S-parameters of the transmitter test load

The following lists equipment that may be used to replicate the S-parameter model shown in figure A.1:

- a) Agilent E8364B PNA series network analyzer;
- b) Agilent N4421B s-parameter test set;
- c) Agilent Physical Layer Test System (PLTS) version 3.01;
- d) Molex 26-circuit External iPass™ Test Fixture (PCB 73931-2540); and
- e) 10 m Mini SAS 4x cable assembly.

NOTE 3 - The Agilent Technologies® Corporation and Molex® equipment are examples of a suitable product(s) available commercially. This information is given for the convenience of users of this standard and does not constitute an endorsement by ANSI or ISO of these products.

NOTE 4 - iPass™ is the trade name of a product supplied by Molex. This information is given for the convenience of users of this standard and does not constitute an endorsement by ANSI, or ISO of the product named. Equivalent products may be used if they lead to the same results.

The equipment is interconnected as shown in figure A.2.

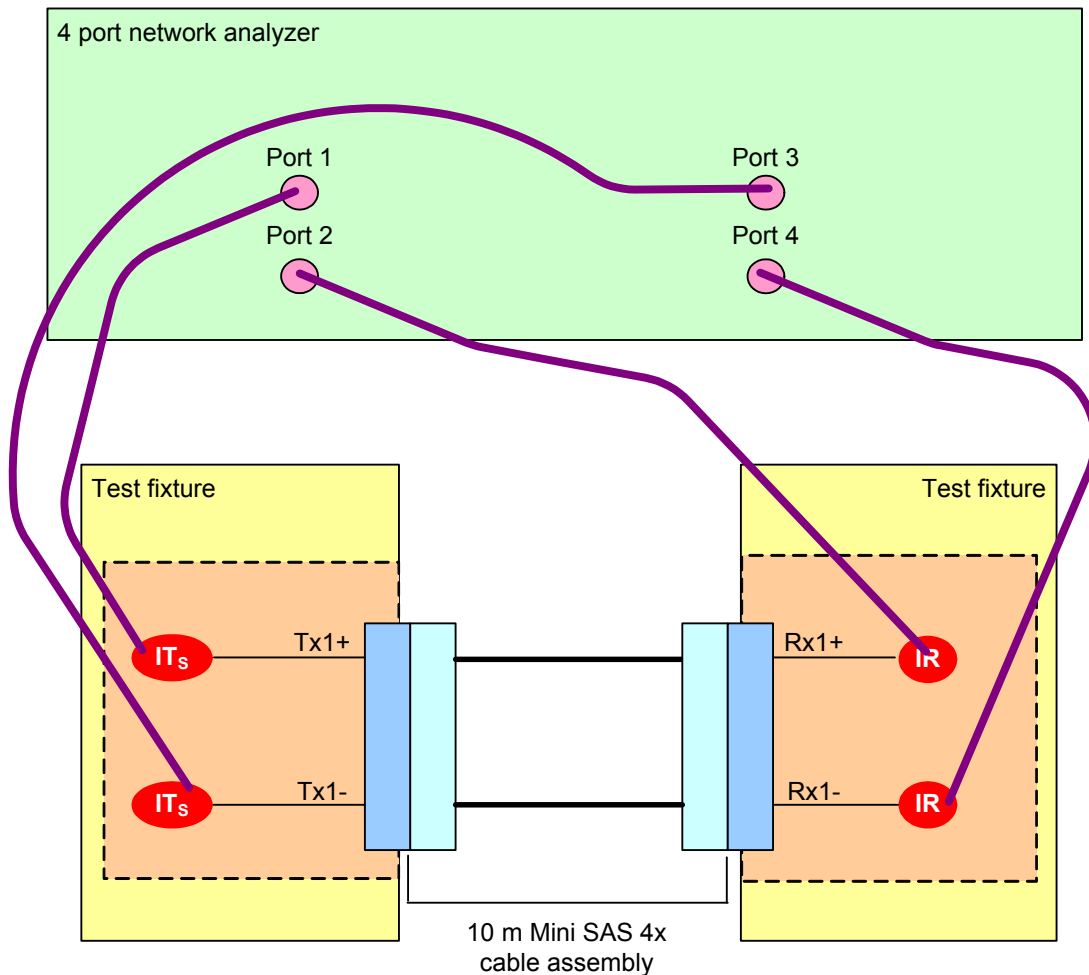

Figure A.2 — S-parameter model of the reference transmitter test load setup

A.1.3 Equipment calibration

The Short-Open-Load-Through (SOLT) calibration procedure should be run before generating the S-parameters.

A.1.4 S-parameter generation

To generate the S-parameters for the reference transmitter test load sweep the 4 port network analyzer from 10 MHz to 20 GHz in 1 MHz steps. The resulting differential insertion loss waveform should be similar to that shown in figure A.3.

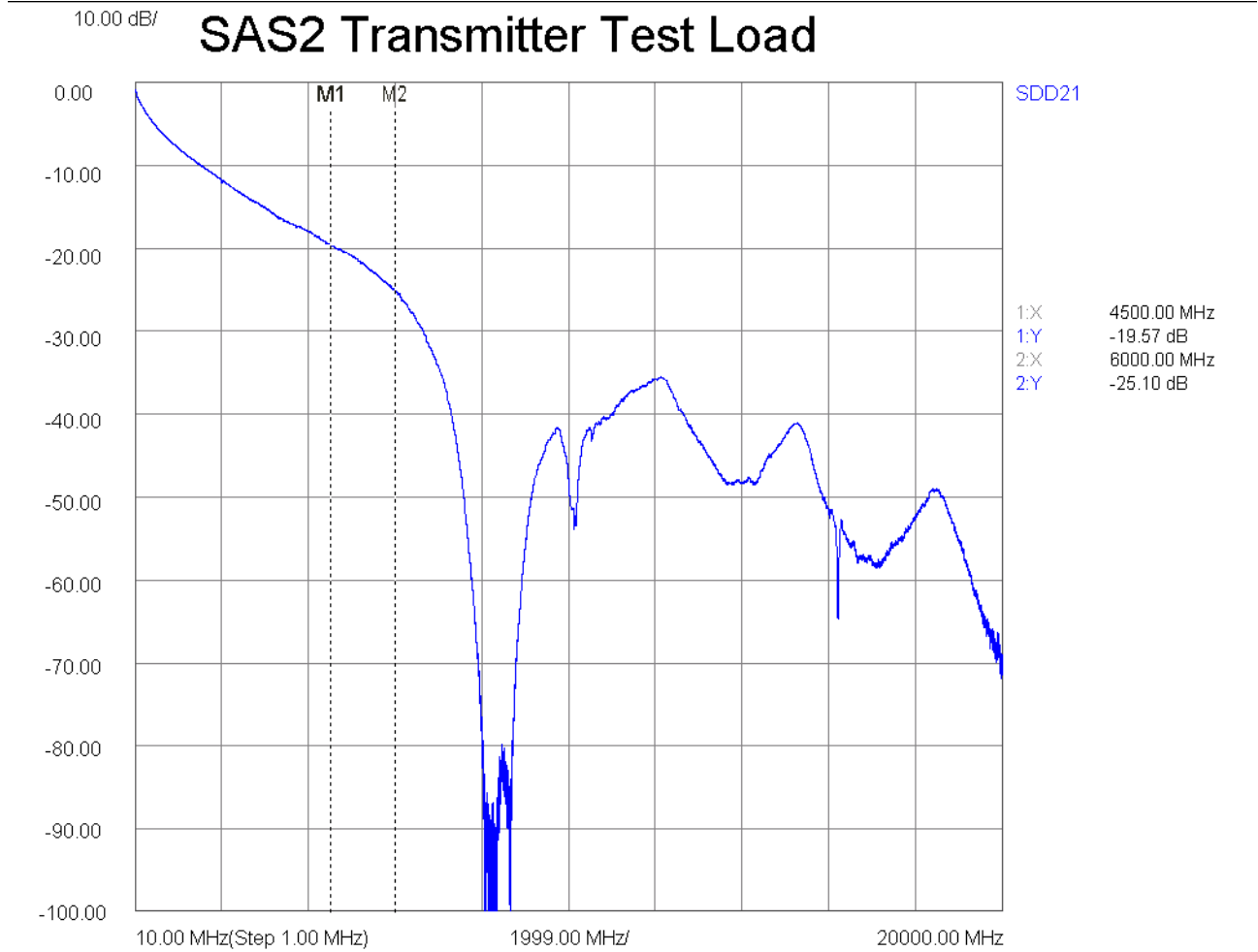

Figure A.3 — Reference transmitter test load waveform