

T10/08-312 revision 0

Date: 7/23/08

To: T10 Committee (SCSI)

From: George Penokie (LSI)

Subject: SAS-2: Making 07-193 into an Annex

1 Overview

This is the re-creation of 07-193r1 putting it into a form that can be placed into the SAS-2 standard as an informative annex.

2 SAS-2 changes

2.0.1 etch: Printed circuit board copper conductor path.

2.0.1.1 Reference transmitter test load

The reference transmitter test load is a 10 m Mini SAS 4x cable assembly.

The reference transmitter test load is used along with the reference receiver device (see 5.3.7.4.3) for simulation of 6 Gbps transmitter device compliance. The specific simulation program used (e.g., StatEye from <http://www.stateye.org>) is not specified by this standard.

~~See Annex A for A an S-parameter model of the reference transmitter test load. is included with this standard. This model includes reference transmitter device (see 5.3.6.5.4) etch, the reference transmitter test load, and reference receiver device (see 5.3.7.4.3) etch. The following files are included:~~

- a) ~~07_193r1_SAS2_transmittertestload.pdf describes how the model was created, including the specific etch configuration; and~~
- b) ~~07_193r1_SAS2_transmittertestload.s4p is a Touchstone® file containing the S parameters of the reference transmitter test load.~~

NOTE 1 - ~~Touchstone® is a registered trademark of Agilent Corporation.~~

Figure 1 shows the physical model used to measure the reference transmitter test load. The etches between the transmission points and probe points may be included in an S-parameter measurement of a TxRx connection. Although these etches add extra loss to the TxRx connection, they are considered to be an

acceptable amount of loss for simulation purposes when restricted to a configuration similar to the reference transmitter test load.

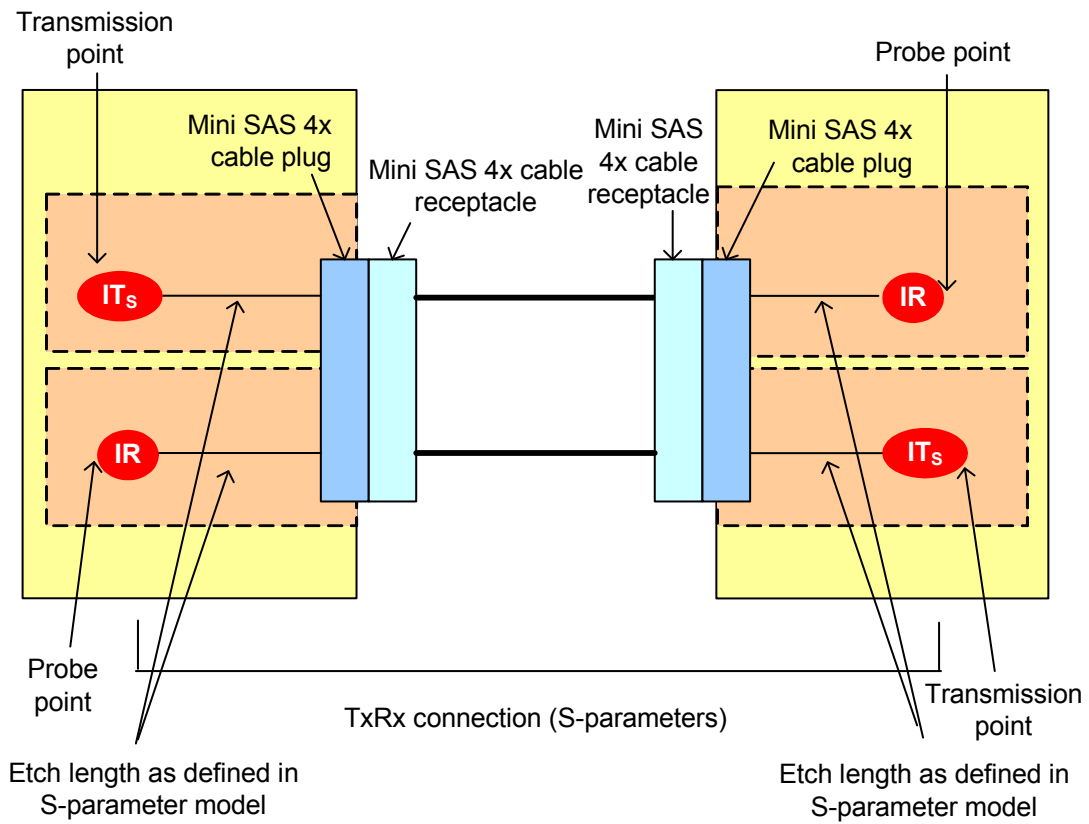

Figure 1 — Reference transmitter test load physical characterization

Annex A
(informative)

S-parameter model

A.1 S-parameter model of the reference transmitter test load

A.1.1 S-parameter model of the reference transmitter test load overview

The S-parameter model of the reference transmitter test load consists of:

- a) an etch length of 50 mm with an etch width of 178 μm between the IT_s (see 5.3.6.5.4) and the SAS 4x cable plug (see figure A.1) in 4000-13 material environment;
- b) 10 m Mini SAS 4x cable assembly; and
- c) an etch length of 50 mm with an etch width of 178 μm between the IR (see 5.3.7.4.3) and the SAS 4x cable plug (see figure A.1) in 4000-13 material environment.

The following Touchstone® file containing the S-parameters of the reference transmitter test load is included:

- a) 07-193r1_SAS2_transmittertestload.s4p.

NOTE 2 - Touchstone® is the trade name of a product supplied by Agilent Corporation. This information is given for the convenience of users of this standard and does not constitute an endorsement by ANSI or ISO of the product named. Equivalent products may be used if they lead to the same results.

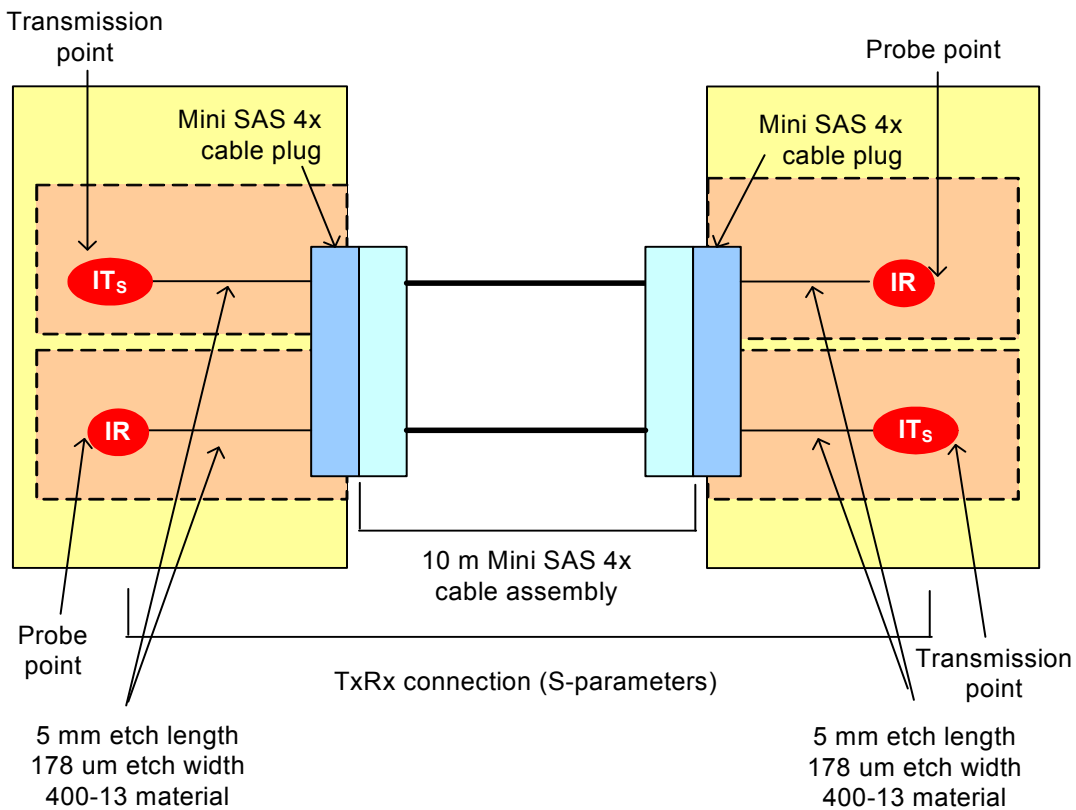

Figure A.1 — S-parameter model of the reference transmitter test load

A.1.2 Equipment setup for generating S-parameters of the transmitter test load

The following lists equipment that may be used to replicate the S-parameter model shown in figure A.1:

- Agilent E8364B PNA series network analyzer;
- Agilent N4421B s-parameter test set;
- Agilent Physical Layer Test System (PLTS) version 3.01;
- Molex 26-circuit External iPass™ Test Fixture (PCB 73931-2540); and
- 10 m Mini SAS 4x cable assembly.

NOTE 3 - The Agilent Corporation and Molex equipment are examples of a suitable product(s) available commercially. This information is given for the convenience of users of this standard and does not constitute an endorsement by ANSI or ISO of these products.

NOTE 4 - iPass™ is the trade name of a product supplied by Molex. This information is given for the convenience of users of this standard and does not constitute an endorsement by ANSI, or ISO of the product named. Equivalent products may be used if they lead to the same results.

The equipment is interconnected as shown in figure A.2.

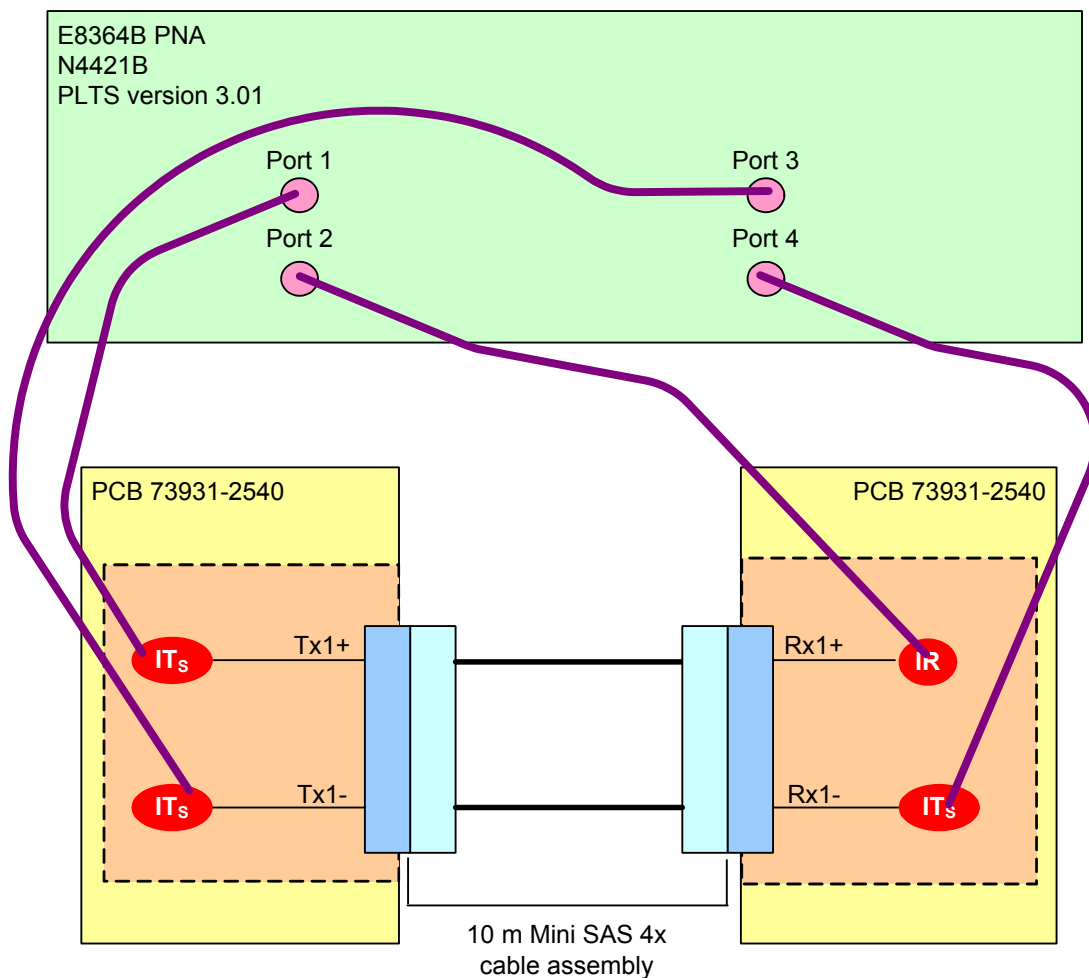

Figure A.2 — S-parameter model of the reference transmitter test load setup

A.1.3 Equipment calibration

The Short-Open-Load-Through (SLOT) calibration procedure should be run before generating the S-parameters.

A.1.4 S-parameter generation

To generate the S-parameters for the reference transmitter test load sweep the Agilent E8364B PNA series network analyzer from 10 MHz to 20 GHz in 1 MHz steps. The result should be the waveform shown in figure A.3.

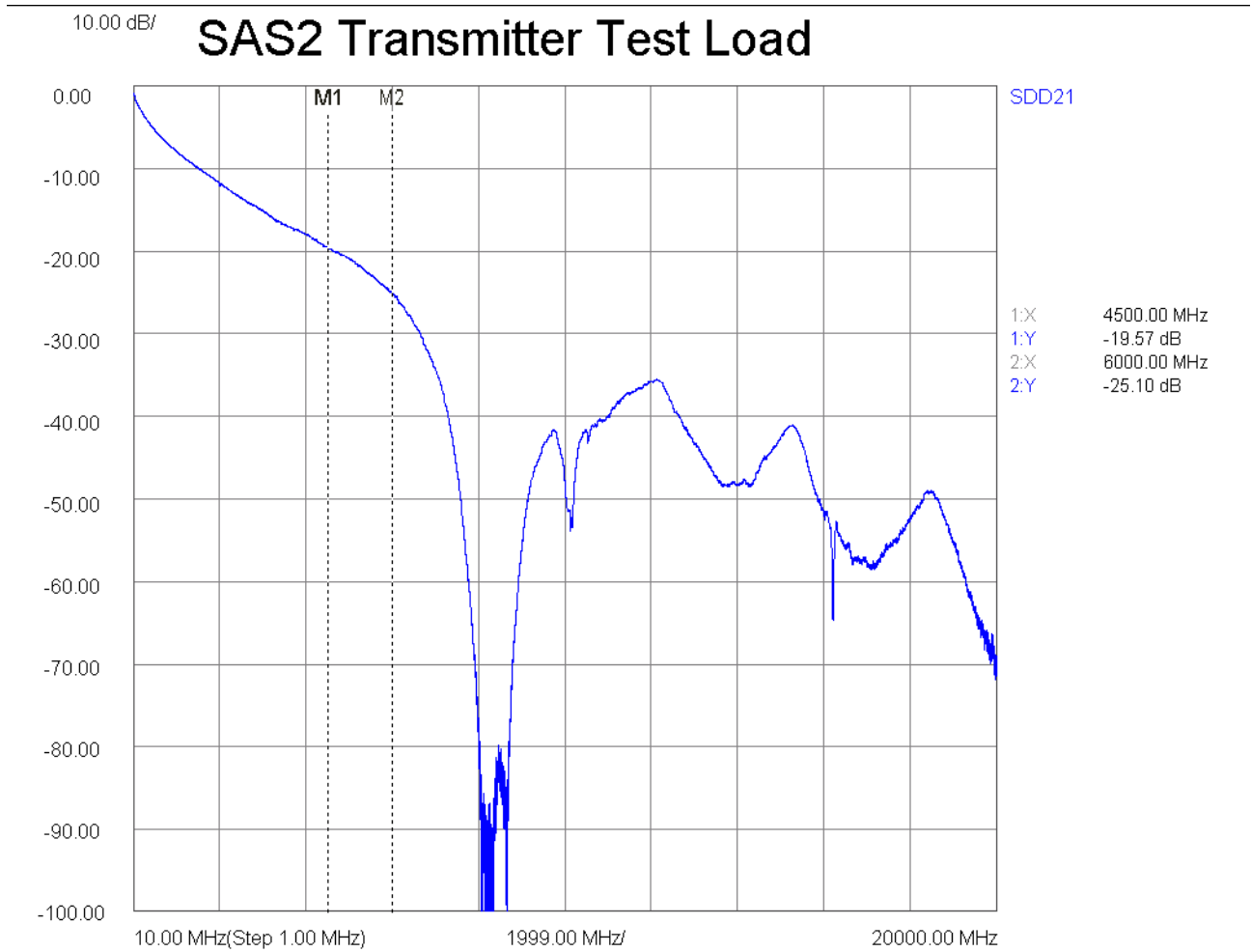

Figure A.3 — Reference transmitter test load waveform