

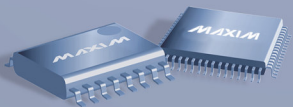

Comments on SAS2r14 Physical Layer

Kevin Witt
March 21, 2008
08-144r1





Outline

- **Preview proposed specification changes, for discussion purposes**
- **Review Proposed Rx Stressed Test Calibration Procedure**

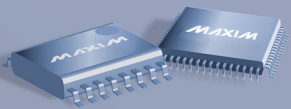



Review Proposed Specification Changes

- Page 203: DFE Equation inconsistent with description.
 - Fix index of summation for $i=1$ to 3
- Page 179:
 - Add pulse response figure (Clean Ref Tx) and Insertion loss plots

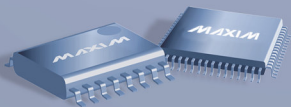
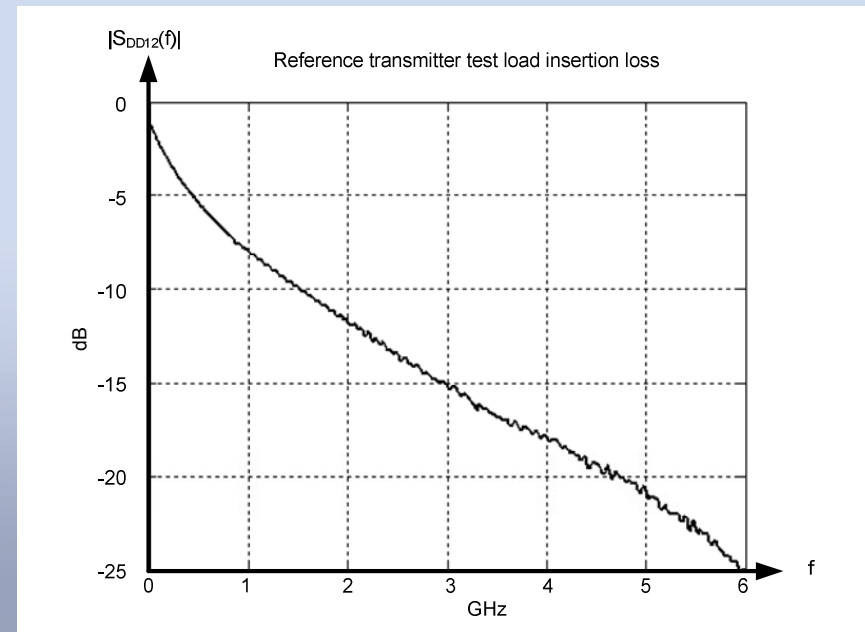
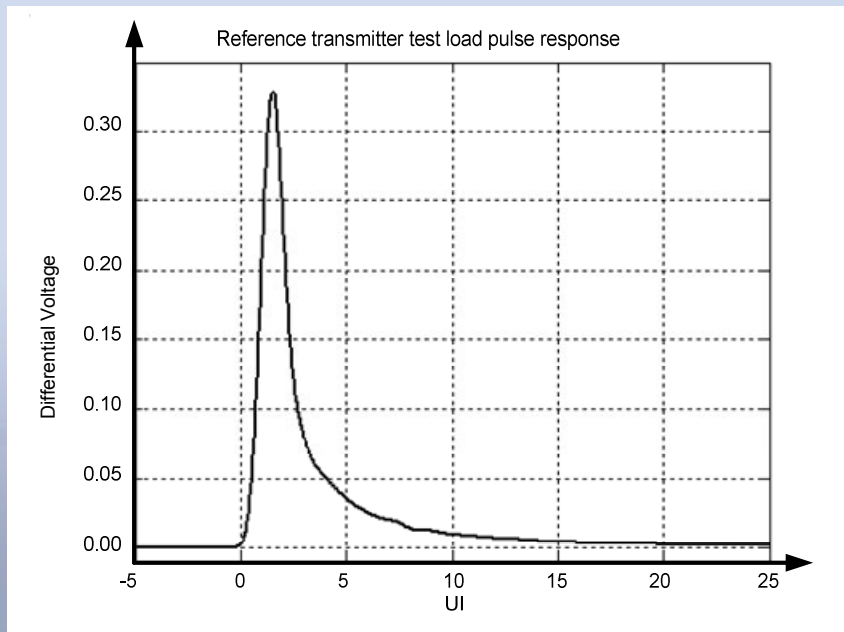



Review Proposed Specification Changes

— Page 205:

- Add D24.3 response graphic
- Change the voltage specification to
- “The difference of the “1” level centroid at the crossing, determined with a vertical histogram, minus the “0” level centroid at the crossing, also determined with a vertical histogram.

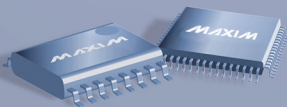
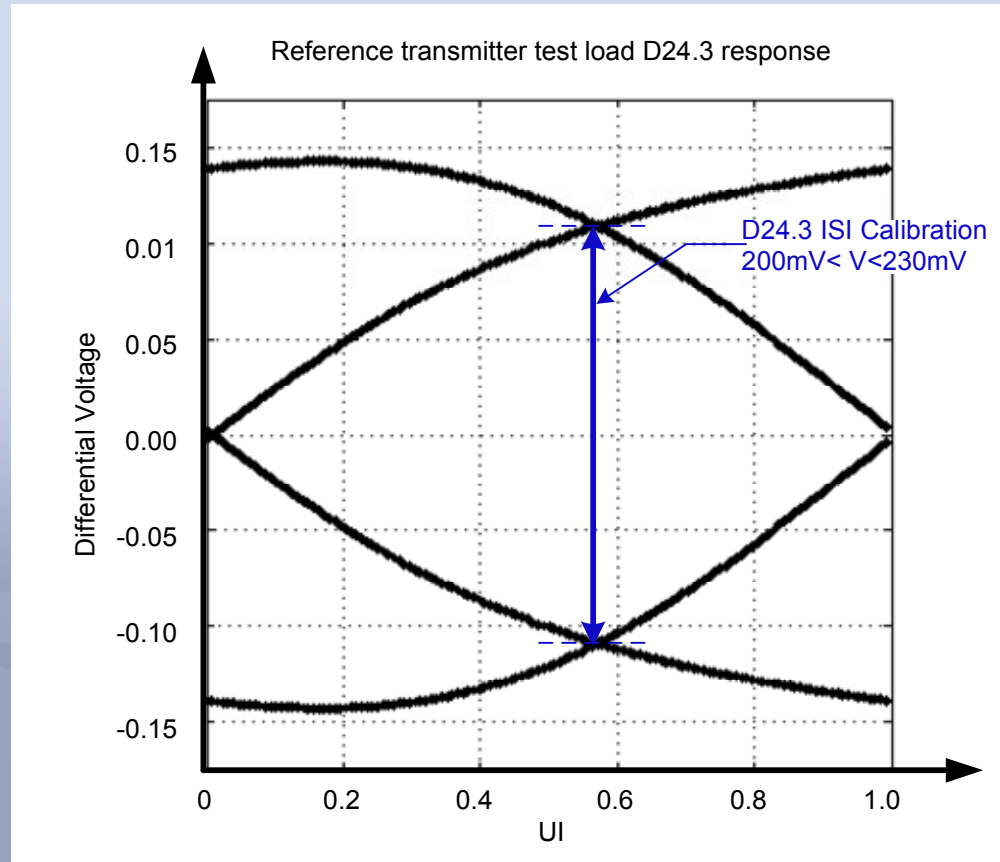



Review Proposed Specification Changes

- Page Figure 127:
 - Visio Drawing,

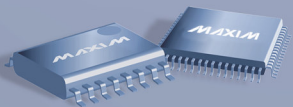
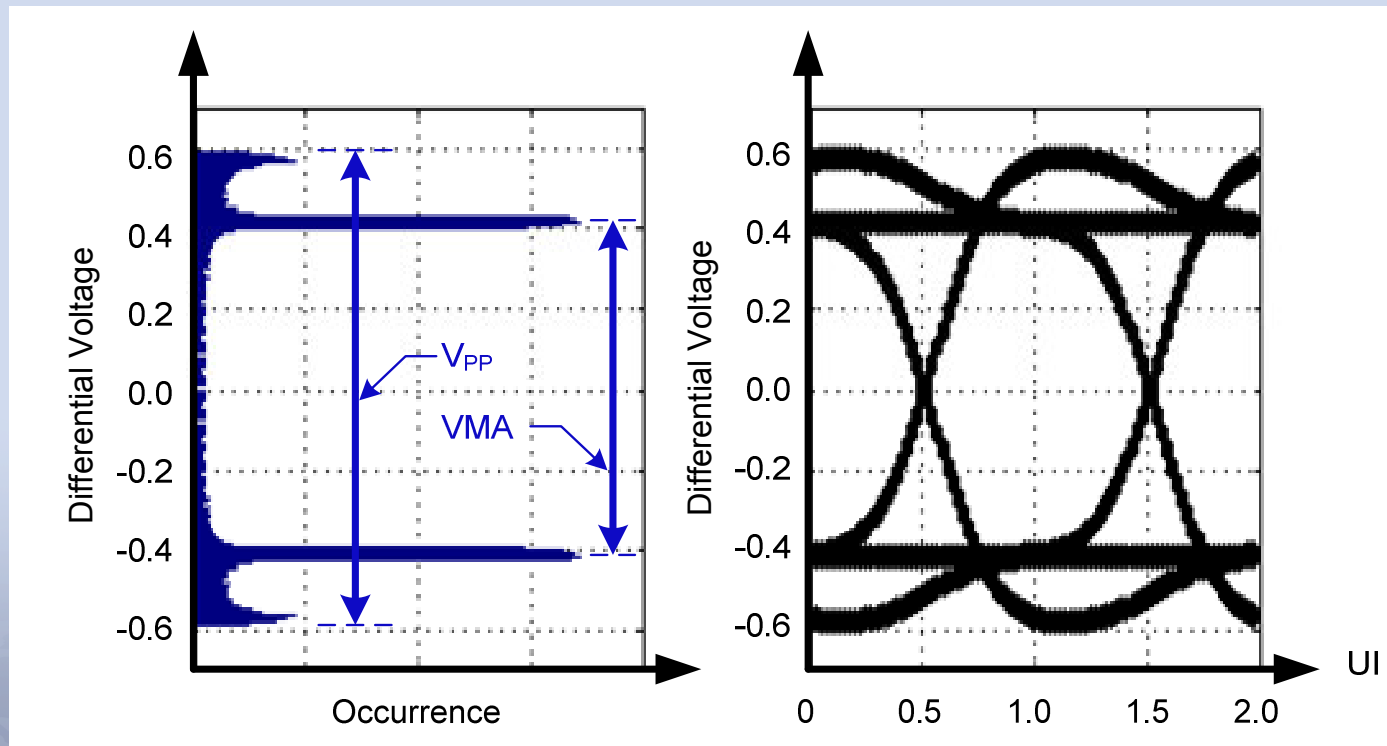



Table 65 Proposed Changes

1. Tx pk-pk 850mV
2. Change DJ to BUJ = 0.1UI
3. Remove Note b

Table 65 — Reference transmitter device characteristics at IT and CT

Characteristic	Units	Value
Peak to peak voltage (V_{P-P}) ^a	mV(P-P)	850
Transmitter equalization ^a	dB	2
Maximum rise/fall time ^c	UI	0.41 (68.3 ps)
RJ	UI	0.15 (25 ps)
BUJ	UI	0.1 (16.6)

^a See 5.3.6.5.5 for measurement method.
^b This is a redacted note.
^c Rise/fall times are measured from 20 % to 80 % of the transition with a repeating 01b or 10b pattern (e.g., D10.2 or D21.5)(see table 235 in 10.2.9.2).

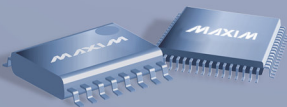



Table 72 Proposed Changes

- Remove Z1 Specification, it does not add to the specification.
- Remove Tx spec, D24.3 delivered eye opening covers this.
- Remove X1 Specification reference to footnote (b), keep spec.
- Modify X1 range to 215 mV Typical and add footnote to specify VMA at crossing, using histogram method at crossing, add diagram.
- Correct BUJ to be 0.1 UI
- Correct RJ UI to ps conversions

Table 72 — Stressed receiver sensitivity test characteristics

Characteristic	Units	Minimum	Typical	Maximum	Reference
Tx data pattern		CJTPAT			Annex A
Tx peak to peak voltage ^f	mV(P-P)		825-875		5.3.6.5.1
Tx minimum rise/fall time	UI	0.24 (41.5 ps)		0.24(40)	5.3.6.5.1
Transmitter equalization ^f	dB		1.7-2.3		5.3.6.5.5
Tx RJ	UI	0.15 (26.6)			5.3.6.5.1
Tx bounded uncorrelated jitter	UI	0.1 (16.6)			
Link dispersion penalty ^{a b}	dB	13			5.3.7.4.4.8
D24.3 delivered eye opening (c,e,f)	mV		200-230		
D24.3 delivered eye opening (c,e,f)	mV				
NEXT offset frequency ^{b d}	ppm	2500			
Total crosstalk amplitude ^{b c}	mV _{rms}	4			

^a Link dispersion penalty is the WDP of the delivered signal computed with Palloc = 15.4 dB.
^b This specification pertains to the delivered signal at IR or CR during the receiver device compliance test. All adjacent phys in the receiver device shall be active with representative traffic with their maximum amplitude and maximum frequency of operation. Additional pseudo-random crosstalk shall be added, if needed, to meet the total crosstalk amplitude specification.
^c Observed with a histogram of at least 1 000 hits.

^d An SSC modulated source can be used instead of fixed offset frequency crosstalk.

^e Based on the centroid of the vertical histogram at 1 and 0 crossing see Figure xxx

^f Test setup is to be within this range and it is not required to show compliance across the range.

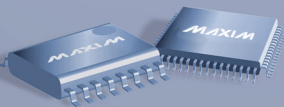

Proposed Change to Figure 131

- Remove BUJ details

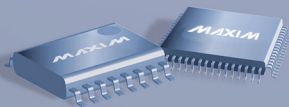
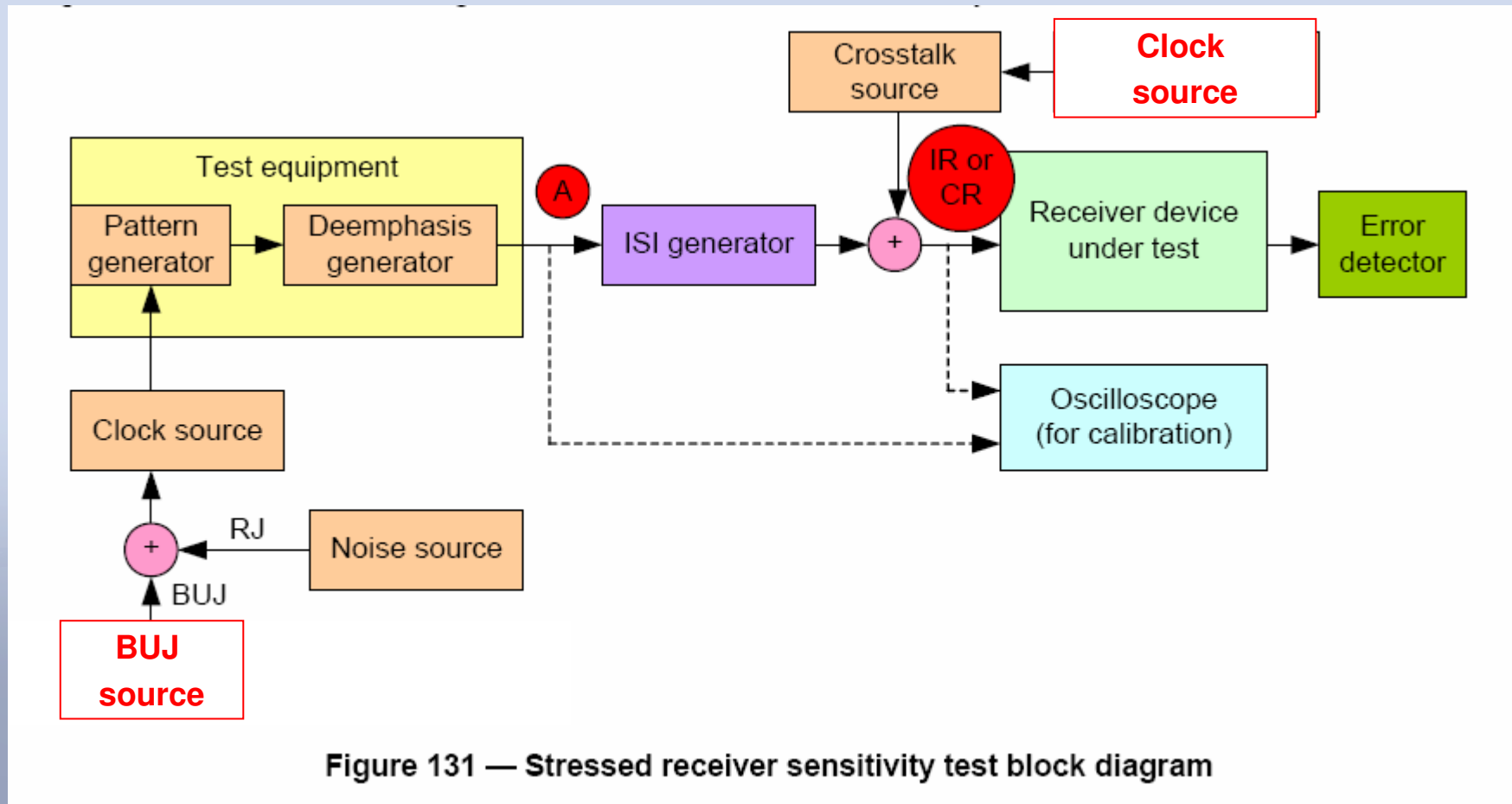

5.3.7.4.4.7 Jitter tolerance

A receiver device shall satisfy the jitter tolerance test described in this subclause. The jitter tolerance test leverages the receiver device physical test hardware. The receiver device under test shall demonstrate a BER that is less than 10^{-12} with a 95 % confidence level when subjected to the sinusoidal jitter defined in 6.6.7.6. **in Figure 122 as illustrated in Figure xxx, with additional fixed SJ of 0.022UI at 20MHz.**

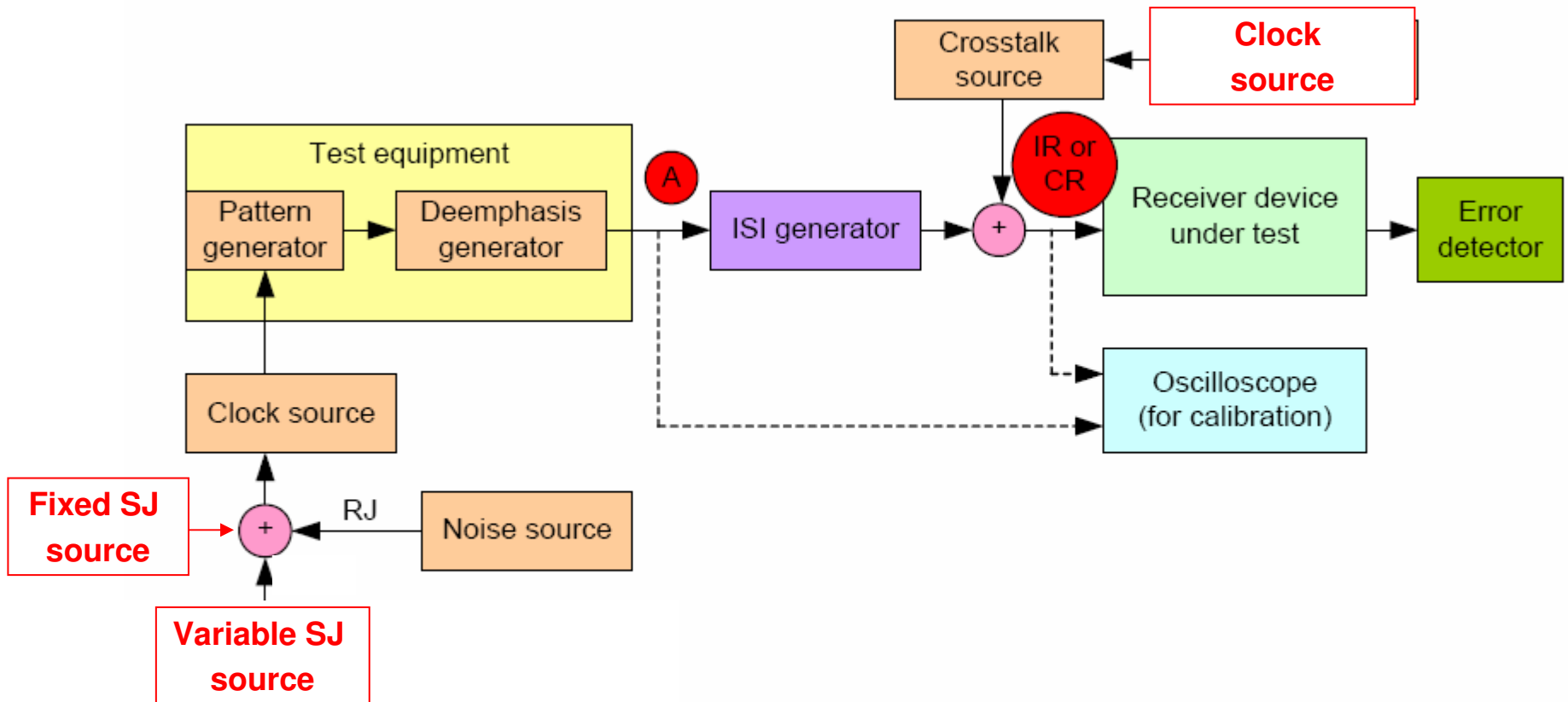

Figure xxx Jitter tolerance test block diagram





Proposed Change to 5.3.7.4.4.7

- **Figure 122 Update**

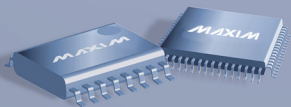
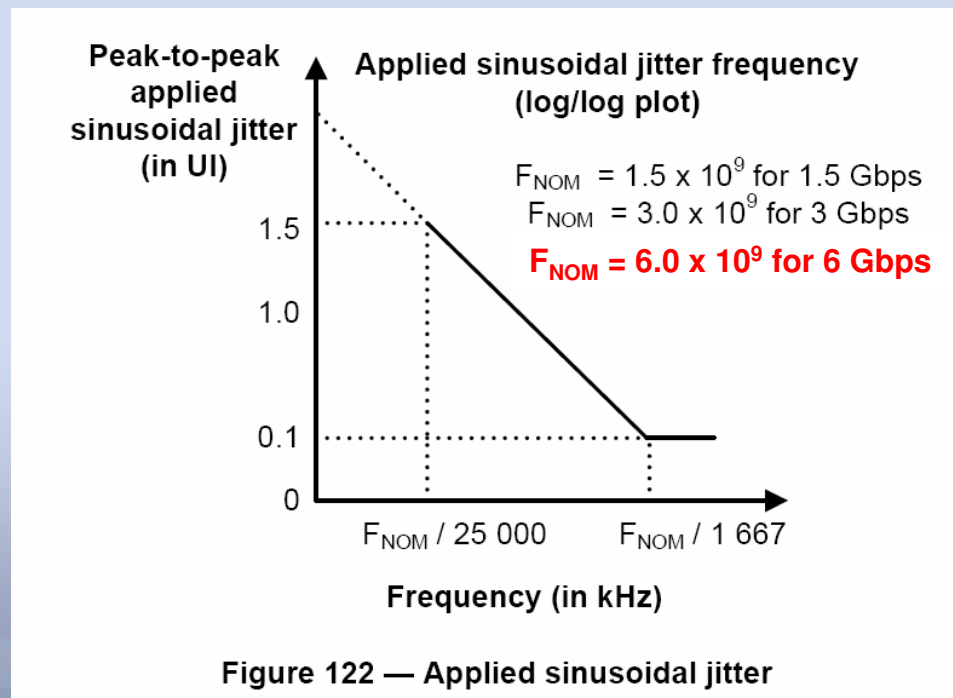



Summary of Proposed Calibration

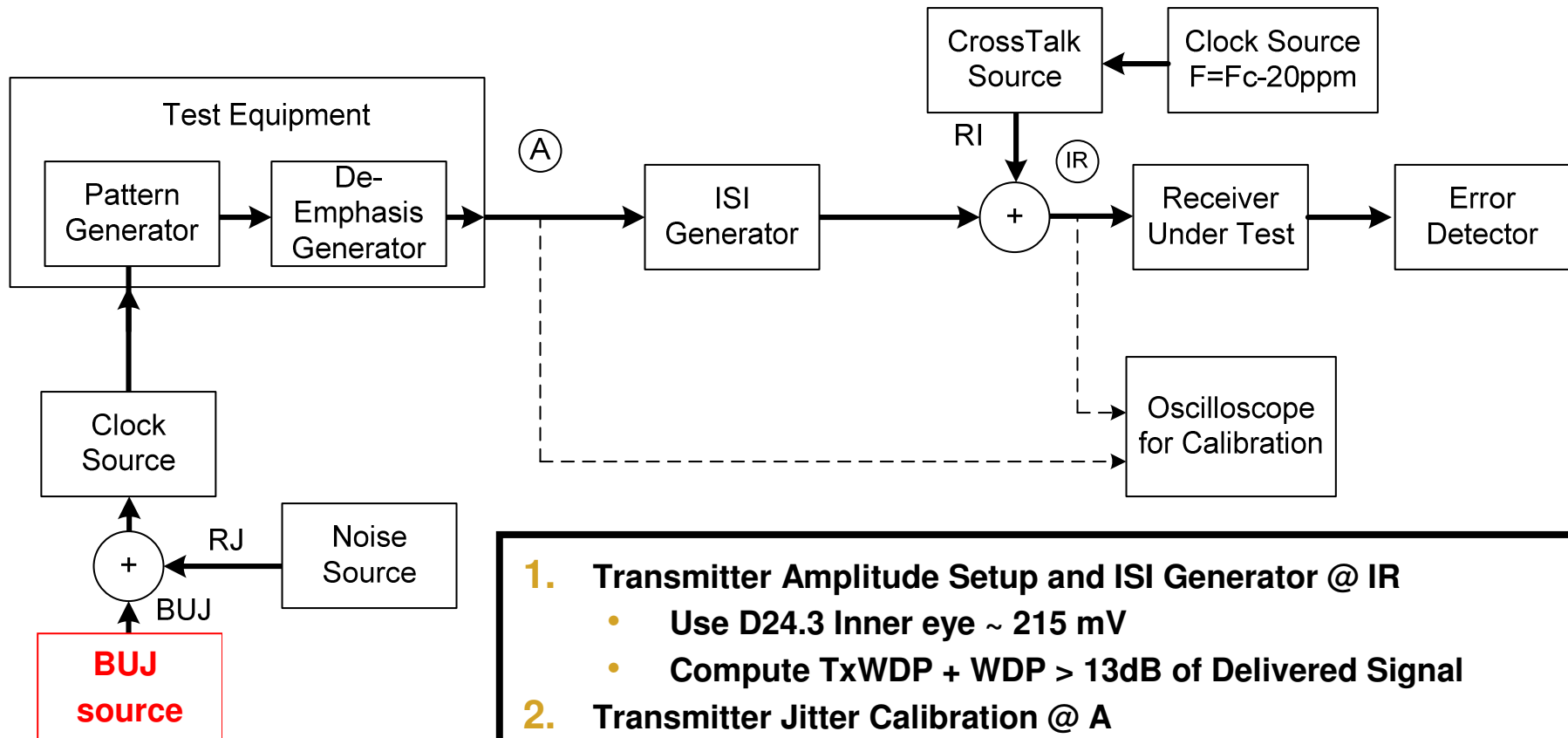

- 1. Transmitter Amplitude Setup and ISI Generator @ IR**
 - Use D24.3 Inner eye ~ 215 mV
 - Compute TxWDP + WDP > 13dB of Delivered Signal
- 2. Transmitter Jitter Calibration @ A**
 - Adjust RJ = 0.15 UI pk-pk
 - Adjust BUJ = 0.1 UI pk-pk
- 3. Crosstalk @ IR**
 - PRBS-7 Crosstalk Source and Adjust Coupled Amplitude > 4mV rms
- 4. Test – Confirm BER < 1e-12**

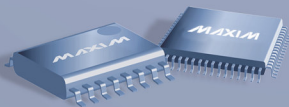



Calibration Procedure Illustrated

1. Measure Inner Eye with D24.3
 - Without jitter or Crosstalk
2. Compute WDP of Delivered Signal with SAS CJTPAT for the budgeted PALLOC of 15.4.
 - Make sure > 13.0 dB
3. Setup Tx Jitter with Standard Test Equipment Options.
 - $RJ = 0.15UI$
 - $BUJ = 0.1UI$
4. Setup Additional Cross talk as needed to meet NEXT limit.
 - Turn on all channels, add crosstalk for a total of 4mV RMS
5. Confirm DUT BER $< 1e-12$ @ 95% confidence

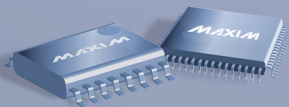
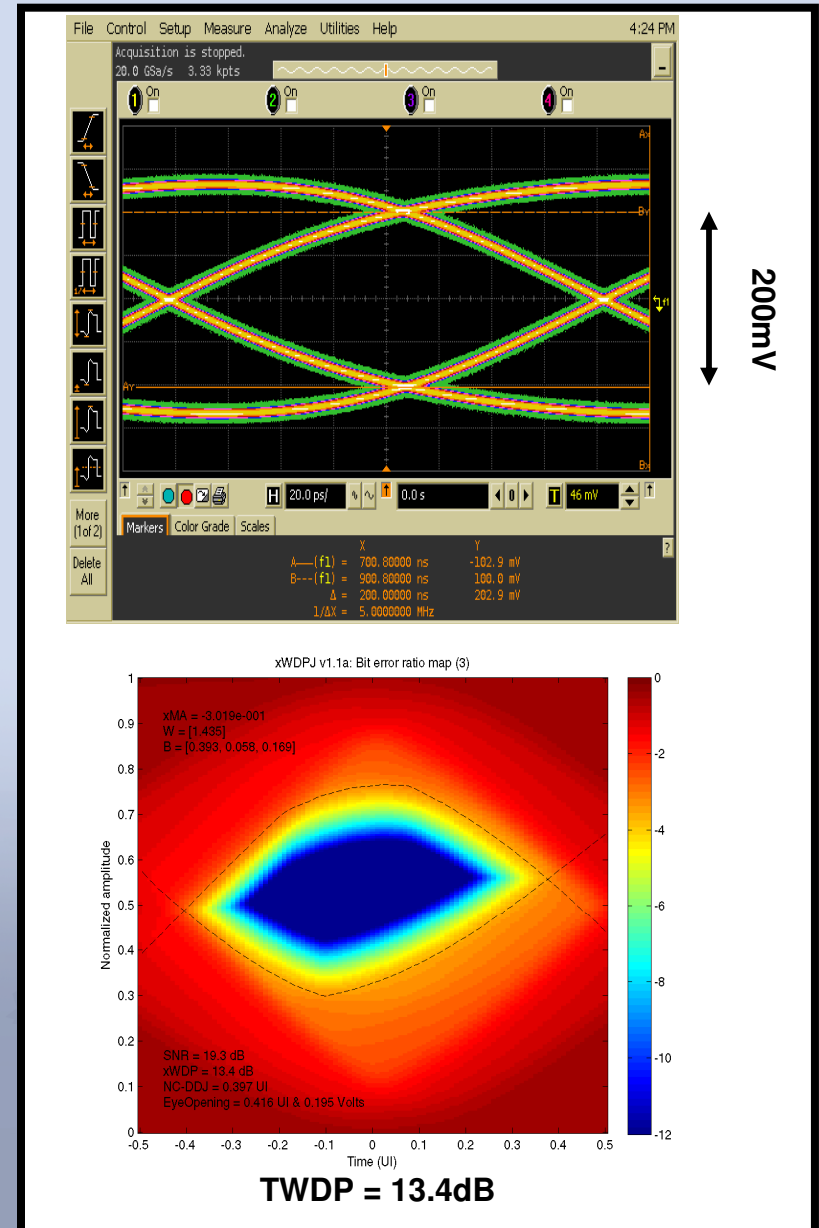



Summary

- **Preview of Proposed Changes Provided**
- **Proposed Method of Calibrating the ISI Generator Appears Feasible and Avoids Golden Hardware.**

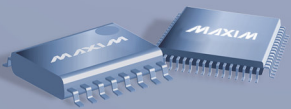



Additional Information

- **References**
- **Updated Link Budget (from 07-380r1)**

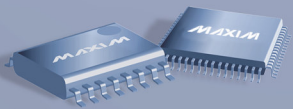

References

- T10/07-339r? SAS-2 6Gbps PHY Electrical Specification
- T10/07-380r1 Comprehensive Stressed Receiver Sensitivity Test (Kevin Witt)
- T10/07-493r0r0 Crosstalk Budget for Receiver Testing
- T10/07-365r0 Enhanced WDP for 6G SAS (Mike Jenkins)
- T10/07-448r0 DFEEYE and SAS-2 Channel Data (Kevin Witt & Mahbubul Bari)
- T10/07-365r0 Enhanced WDP for 6G SAS (Mike Jenkins)
- T10-07-193r1 Transmitter Test Load (Galen Fromm)
- T11/07-399v1 Beta and Epsilon Point Update (Adam Healey & Mark Marlett)
- T11/07-592v0 Migrating Beta and Epsilon Points to DFEEYE (Adam Healey & Mark Marlett)
- T11/07-344v0 Enhancing WDP (Adam Healey & Mark Marlett)
- T11/07-553v1 TWDP/WDP code for 8GFC SA and EA-delta points (Lindsay & Ghiasi)
- T11/07-644v0 Enhanced TWDP and WDP (Adam Healey & Mark Marlett)
- T11/07-706v0 Informative Eye Diagram Display for Enhanced TWDP and WDP (Adam Healey)

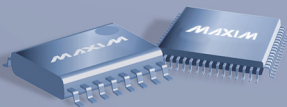

Link Budget

- From 07-365r0

VMA at Output of Channel →

Tx Waveform and Channel Dispersion Penalty →

Theoretical Required VMA Post Equalization →

Near End Cross Talk →

$VMA = Q \cdot (\sigma_1 + \sigma_0)$

$VMA = 7.03 * (3.4 + 3.4) = 48$ →

$Q = \frac{VMA}{\sigma_1 + \sigma_0}$ →

