

07-486r0 SAS-2 Receiver Device Physical Testing

To: T10 Technical Committee

From: Kevin Witt (Kevin.witt@maxim-ic.com) & Mahbubul Bari

Date: 1/15/2008

Subject: 07-486r0 SAS-2 Receiver Device Physical Testing

Revision History

Revision 0 (6 November 2007) First revision

Related Documents

T10/07-339r6 SAS-2 6Gbps PHY Electrical Specification

T10/07-492r1 Transmitter Waveform Calibration for Receiver Testing (Kevin Witt & Mahbubul Bari)

T10/07-49xr0 Crosstalk Budget for Receiver Testing (Kevin Witt & Mahbubul Bari)

T10/07-448r0 DFEEYE and SAS-2 Channel Data (Kevin Witt & Mahbubul Bari)

T10/07-380r1 Comprehensive Stressed Receiver Sensitivity Test (Kevin Witt)

T10/07-365r0 Enhanced WDP for 6G SAS (Mike Jenkins)

T10-07-193r1 Transmitter Test Load (Galen Fromm)

T11/07-399v1 Beta and Epsilon Point Update (Adam Healey & Mark Marlett)

T11/07-592v0 Migrating Beta and Epsilon Points to DFEEYE (Adam Healey & Mark Marlett)

T11/ 07-344v0 Enhancing WDP (Adam Healey & Mark Marlett)

T11/07-553v1 TWDP/WDP code for 8GFC SA and EA-delta points (Lindsay & Ghiasi)

T11/07-644v0 Enhanced TWDP and WDP (Adam Healey & Mark Marlett)

T11/07-706v0 Informative Eye Diagram Display for Enhanced TWDP and WDP (Adam Healey)

Overview

A concise stressed receiver sensitivity test definition is desired for SAS-2 to ease compliance testing of SAS-2 receivers. Per group approval at the Lisle IL meeting this draft wording was drafted.

Proposal

Replace section 5.3.7.4.4 in 07-339r6 with this text.

5.3.7.4.4 Receiver device physical testing

A compliant SAS-2 receiver shall satisfy the stressed receiver sensitivity test described in this section. The receiver under test must demonstrate a BER of better than 1×10^{-12} with a confidence level of 95%. The BER is computed on the raw bit stream before 8b10b decoding.

Table 72 – Bits versus bit errors for 95% confidence level of less than 10^{-12} BER performance

Characteristics	95% confidence level of less than 10^{-12} BER performance					
Number of errors	0	1	2	3	4	5
Number of bits	$3,0 \times 10^{12}$	$4,74 \times 10^{12}$	$6,3 \times 10^{12}$	$7,75 \times 10^{12}$	$9,15 \times 10^{12}$	$1,05 \times 10^{13}$

The following test shall be applied at the receiver device compliance point (IR or CR) as a means to perform physical validation of predicted performance of the receiver. Figure 126 shows the block diagram of the stressed receiver sensitivity test.

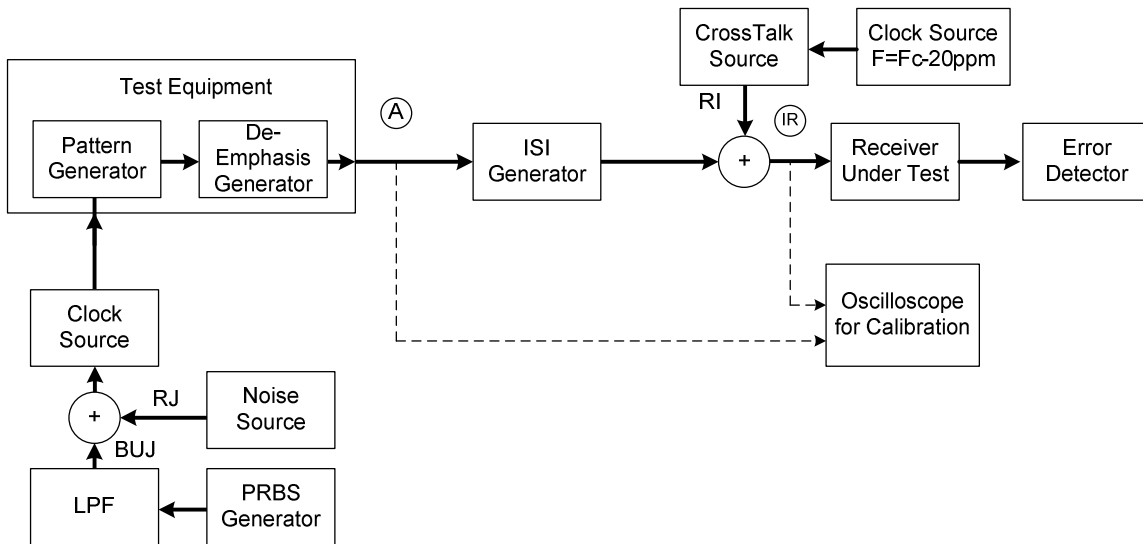

Figure 126 -- SAS-2 Stressed Receiver Sensitivity Test Block Diagram

The design under test will demonstrate its ability to compensate for channel Inter Symbol Interference (ISI) representative of the SAS-2 reference channel while subjected to the budgeted jitter and cross talk sources.

As illustrated in the Figure 126, test equipment is used to generate a representative transmitted waveform (A) with the electrical characteristics of Table 73.

Table 73 -- Stressed Receiver Sensitivity Test Electrical Parameters

Signal Characteristic	Units	Min	Typ	Max	Reference
Tx Data Pattern			CJTPAT		
Tx Peak to peak voltage	mV (P-P)			800	5.3.6.5.1
Tx Minimum Rise / Fall Time	UI(ps)	0,25(41,667)			5.3.6.5.1
Tx De-Emphasis	dB			2	5.3.6.5.5
Tx Random Jitter	UI(ps)	0,15(25)			5.3.6.5.1
Tx Bounded Uncorrelated Jitter	UI(ps)	0,00022(0,036)			
Link Dispersion Penalty (LDP) ^{a,b}	dB	13			
D24.3 Delivered Eye Opening (Z1) ^b	mV	60		90	5.3.5.1
D24.3 Delivered Eye Opening (X1) ^b	UI	0,15			5.3.5.1
NEXT Offset Frequency ^b	PPM		20		
Total Crosstalk Amplitude ^b	mV rms	4			

Note:

a) Link Dispersion Penalty is the WDP of the Delivered Signal Computed with Palloc = 15,4 dB

b) This specification pertains to the deliver signal at IR or CR during the receiver compliance test. All adjacent PHY in the device are to be active with representative traffic at the max frequency of operation and swing. Additional pseudo-random crosstalk is to be added, if needed, to meet the total crosstalk amplitude specification.

5.3.7.4.4.1 Test signal characteristics and calibration

Any implementation of the stressed signal generation hardware is permitted for the stressed receiver signal as long as it provides the resulting ISI stressed signal, jitter and noise as defined in this section.

5.3.7.4.4.2 Transmit Waveform Calibration

The transmit launch signal is established at point A in Figure 126 per the electrical parameters of Table 73 using test equipment. Waveform calibrations are per references in Table 73.

5.3.7.4.4.3 ISI Stressor Calibration

The hardware ISI generator must deliver a stressed signal to the receiver under test that is representative, and at least as stressful as the SAS-2 reference channel. The measure of stress is the computed Link Dispersion Penalty (LDP) and the insertion loss at Fbaud/2. With the transmitter jitter and crosstalk sources disabled the delivered waveform is captured at (IR) and processed to determine the LDP. Waveform averaging is used to minimize the impact of measurement noise and jitter on the LDP calculations.

Per T10-07-193 the SAS-2 reference channel's differential insertion loss is illustrated below and leads to a nominal ISI generators insertion loss requirement of -15dB at Fbaud/2. The insertion loss is measured by observing the delivered eye opening at CR and IR per the specification in Table 73. This is calibration is illustrated in Figure 128.

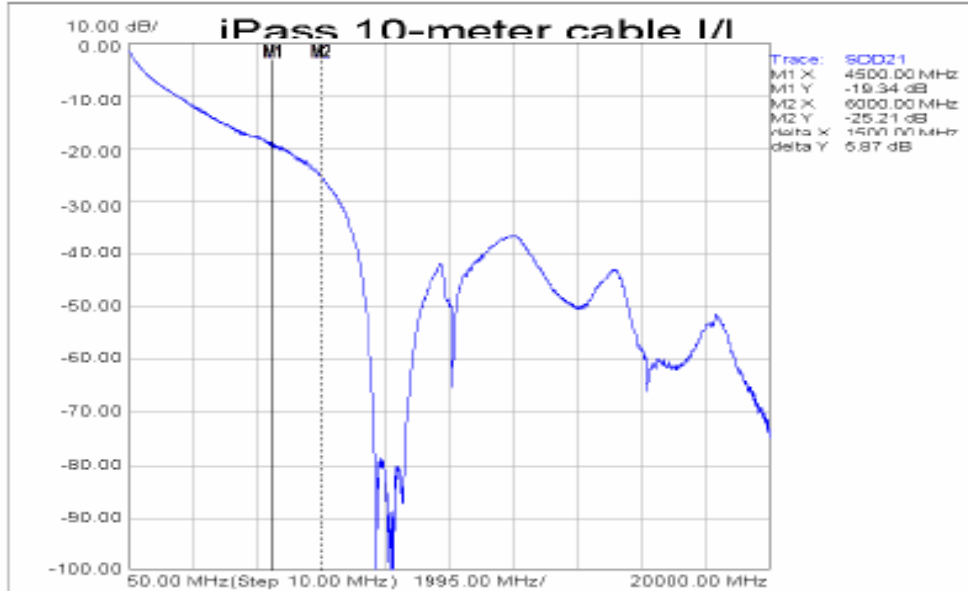

Figure 127 -- SAS-2 Reference Channel Differential Insertion Loss

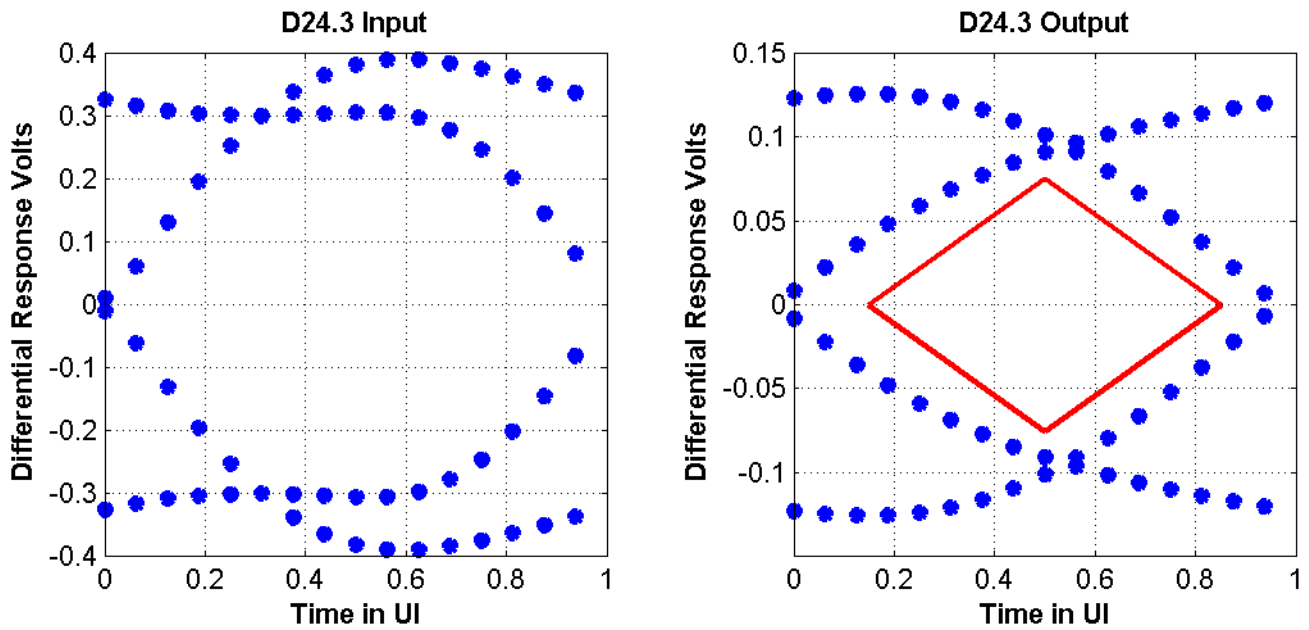

Figure 128 – SAS-2 Reference Channel Response to D24.3

A representative delivered pulse response for this channel when driven with a transmit source (per Table 73) is illustrated in Figure 129 and Table 74.

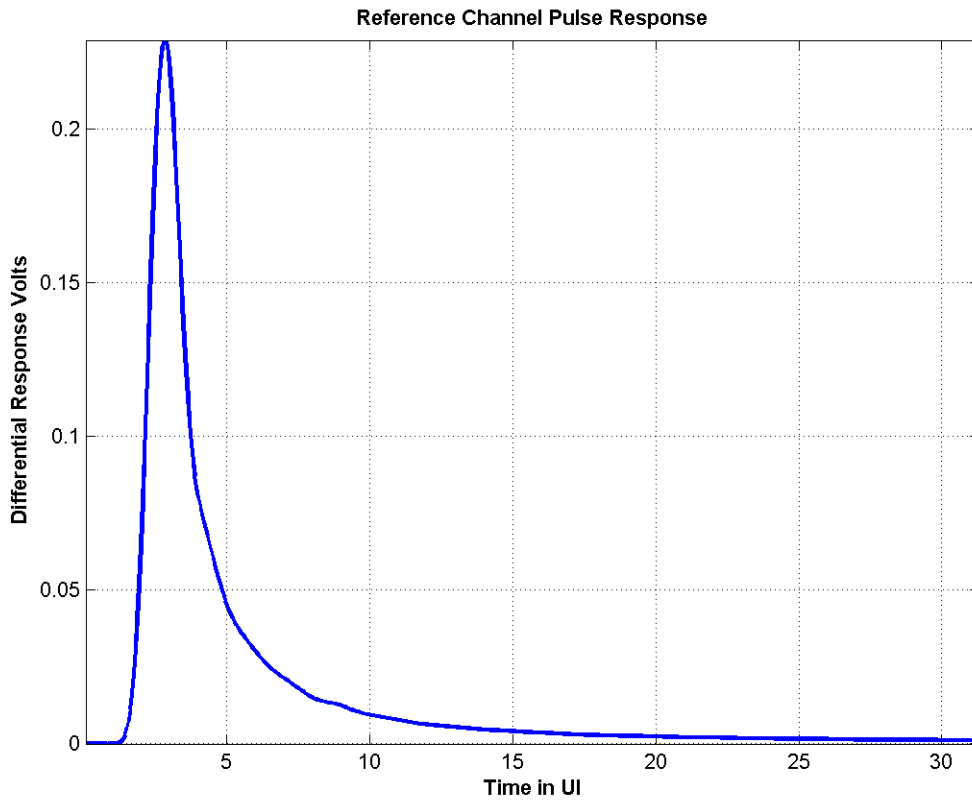

Figure 129 -- Reference Channel Delivered Pulse Response

Table 74 -- ISI Generator Pulse Response

Time (UI)	Resp	Time (UI)	Resp	Time (UI)	Resp	Time (UI)	Resp	Time (UI)	Resp	Time (UI)	Resp
0.000	0.000	3.063	0.072	6.188	0.019	9.313	0.009	12.438	0.005	15.563	0.003
0.063	0.000	3.125	0.070	6.250	0.019	9.375	0.009	12.500	0.005	15.625	0.003
0.125	0.000	3.188	0.068	6.313	0.018	9.438	0.009	12.563	0.005	15.688	0.003
0.188	0.000	3.250	0.066	6.375	0.018	9.500	0.009	12.625	0.005	15.750	0.003
0.250	0.001	3.313	0.063	6.438	0.018	9.563	0.008	12.688	0.005	15.813	0.003
0.313	0.002	3.375	0.061	6.500	0.017	9.625	0.008	12.750	0.005	15.875	0.003
0.375	0.003	3.438	0.059	6.563	0.017	9.688	0.008	12.813	0.005	15.938	0.003
0.438	0.005	3.500	0.056	6.625	0.016	9.750	0.008	12.875	0.005	16.000	0.003
0.500	0.008	3.563	0.054	6.688	0.016	9.813	0.008	12.938	0.005	16.063	0.003
0.563	0.012	3.625	0.052	6.750	0.016	9.875	0.008	13.000	0.005	16.125	0.003
0.625	0.017	3.688	0.050	6.813	0.015	9.938	0.008	13.063	0.005	16.188	0.003
0.688	0.023	3.750	0.048	6.875	0.015	10.000	0.008	13.125	0.005	16.250	0.003
0.750	0.031	3.813	0.047	6.938	0.015	10.063	0.008	13.188	0.005	16.313	0.003
0.813	0.041	3.875	0.045	7.000	0.014	10.125	0.007	13.250	0.004	16.375	0.003
0.875	0.052	3.938	0.044	7.063	0.014	10.188	0.007	13.313	0.004	16.438	0.003
0.938	0.065	4.000	0.042	7.125	0.014	10.250	0.007	13.375	0.004	16.500	0.003
1.000	0.079	4.063	0.041	7.188	0.014	10.313	0.007	13.438	0.004	16.563	0.003
1.063	0.095	4.125	0.040	7.250	0.014	10.375	0.007	13.500	0.004	16.625	0.003
1.125	0.111	4.188	0.039	7.313	0.014	10.438	0.007	13.563	0.004	16.688	0.003
1.188	0.128	4.250	0.038	7.375	0.014	10.500	0.007	13.625	0.004	16.750	0.003
1.250	0.146	4.313	0.037	7.438	0.013	10.563	0.007	13.688	0.004	16.813	0.003
1.313	0.162	4.375	0.036	7.500	0.013	10.625	0.007	13.750	0.004	16.875	0.003
1.375	0.178	4.438	0.035	7.563	0.013	10.688	0.007	13.813	0.004	16.938	0.003
1.438	0.192	4.500	0.035	7.625	0.013	10.750	0.006	13.875	0.004	17.000	0.003
1.500	0.204	4.563	0.034	7.688	0.013	10.813	0.006	13.938	0.004	17.063	0.003
1.563	0.214	4.625	0.033	7.750	0.013	10.875	0.006	14.000	0.004	17.125	0.003
1.625	0.222	4.688	0.032	7.813	0.013	10.938	0.006	14.063	0.004	17.188	0.003
1.688	0.227	4.750	0.032	7.875	0.012	11.000	0.006	14.125	0.004	17.250	0.003
1.750	0.229	4.813	0.031	7.938	0.012	11.063	0.006	14.188	0.004	17.313	0.003
1.813	0.228	4.875	0.030	8.000	0.012	11.125	0.006	14.250	0.004	17.375	0.003
1.875	0.225	4.938	0.029	8.063	0.012	11.188	0.006	14.313	0.004	17.438	0.003
1.938	0.219	5.000	0.029	8.125	0.012	11.250	0.006	14.375	0.004	17.500	0.003
2.000	0.211	5.063	0.028	8.188	0.011	11.313	0.006	14.438	0.004	17.563	0.003
2.063	0.202	5.125	0.027	8.250	0.011	11.375	0.006	14.500	0.004	17.625	0.003
2.125	0.191	5.188	0.027	8.313	0.011	11.438	0.006	14.563	0.004	17.688	0.003
2.188	0.179	5.250	0.026	8.375	0.011	11.500	0.006	14.625	0.004	17.750	0.003
2.250	0.167	5.313	0.025	8.438	0.010	11.563	0.006	14.688	0.004	17.813	0.003
2.313	0.155	5.375	0.025	8.500	0.010	11.625	0.006	14.750	0.004	17.875	0.003
2.375	0.143	5.438	0.024	8.563	0.010	11.688	0.006	14.813	0.004	17.938	0.003
2.438	0.132	5.500	0.024	8.625	0.010	11.750	0.006	14.875	0.004	18.000	0.003
2.500	0.122	5.563	0.023	8.688	0.010	11.813	0.006	14.938	0.004	18.063	0.003
2.563	0.113	5.625	0.023	8.750	0.010	11.875	0.006	15.000	0.004	18.125	0.003
2.625	0.105	5.688	0.023	8.813	0.010	11.938	0.005	15.063	0.004	18.188	0.003
2.688	0.098	5.750	0.022	8.875	0.010	12.000	0.005	15.125	0.004	18.250	0.003
2.750	0.092	5.813	0.022	8.938	0.009	12.063	0.005	15.188	0.004	18.313	0.003
2.813	0.087	5.875	0.021	9.000	0.009	12.125	0.005	15.250	0.004	18.375	0.003
2.875	0.083	5.938	0.021	9.063	0.009	12.188	0.005	15.313	0.003	18.438	0.003
2.938	0.080	6.000	0.020	9.125	0.009	12.250	0.005	15.375	0.003	18.500	0.003
3.000	0.077	6.063	0.020	9.188	0.009	12.313	0.005	15.438	0.003	18.563	0.003
3.063	0.075	6.125	0.020	9.250	0.009	12.375	0.005	15.500	0.003	18.625	0.003

The captured waveform is processed as described in section 5.3.7.4.4.6 to determine the LDP. An ISI generator suitable for this test will have a LDP greater than the budgeted and an insertion loss comparable to the reference channels per Table 74.

5.3.7.4.4.4 Cross talk calibration

A coupling mechanism is used to inject representative crosstalk to the receiver under test (IR or CR). The center frequency of the crosstalk source is frequency offset from the link under test to sweep all potential relative phase alignments between the aggressor and link under test. With the transmit signal disabled a histogram of the signal delivered to the receiver under test. The RMS crosstalk shall be at greater than the RMS specified in Table 73 when observed with a histogram of at least 1000 hits.

5.3.7.4.4.5 SAS-2 Jitter Tolerance

A compliant SAS-2 receiver shall satisfy the Jitter tolerance test described in this section. The jitter tolerance test leverages the receiver device physical test hardware. The receiver under test must demonstrate a BER of better than 1×10^{-12} with a 95% confidence level when subjected to the sinusoidal jitter of Figure 117. The Jitter tolerance test uses the electrical characteristics of Table 73 with the Transmitter RJ and BUJ jitter minimized.

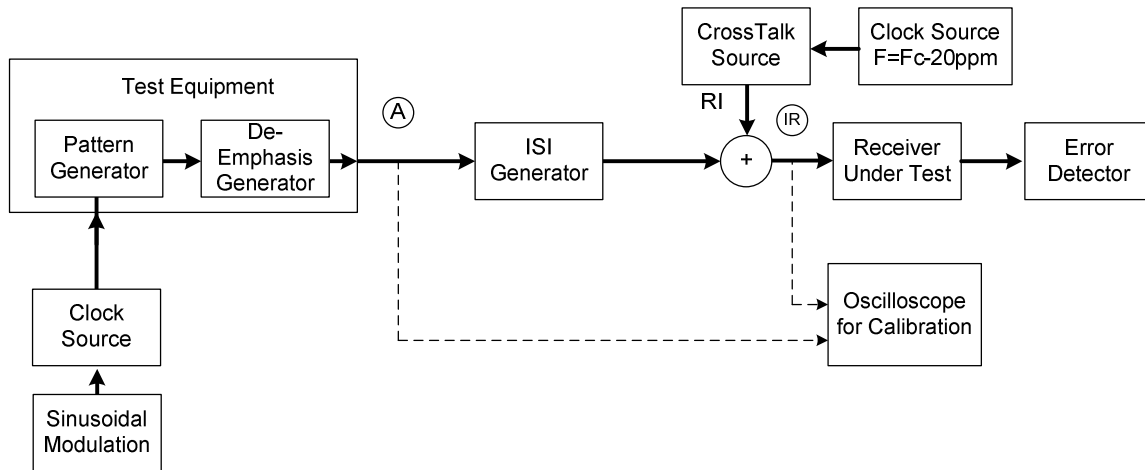

Figure 130 -- Jitter Tolerance Test Configuration

5.3.7.4.4.6 Link Dispersion Penalty Signal Processing Algorithm

The LDP computation algorithm can be found in T11-706r0.