

TO: T10 Membership
FROM: Paul A. Suhler, Quantum Corporation
DATE: 6 October 2008
SUBJECT: T10/07-469r9, ADT-2: Internet ADT (iADT)

Revisions

- 0 [Initial revision](#) (2 November 2007)
- 1 [First revision](#) (9 March 2008)
Changed name to Network ADT (iADT).
Added registered port number.
Allowed iADT ports to use any port number.
Removed iADT-specific baud rate and Timeout_{ACK}.
- 2 [Second revision](#) (11 April 2008)
Deleted the ABORT service request and the ABORTED service indication.
Added analysis of existing state machines, link services, and frame header fields.
Added analysis of physical layer connections.
- 3 [Third revision](#) (30 April 2008)
Added discussion of including legacy ADT signals in new Custom Connector section.
Added proposed connector signal name and pinout.
- 4 [Fourth revision](#) (29 May 2008)
Separated the concept of an “ADT port” from an “ADT interconnect port.”
Added link layer protocol services generic to all physical layers, as well as mappings to RS-422, TCP, and UDP.
Added requirement for ADT ports using Ethernet to ignore negotiated baud rate in computing acknowledgement timeout.
- 5 [Fifth revision](#) (13 June 2008)
Incorporated changes from 4 June 2008 teleconference, minutes in [T10/08-256r0](#).
Enhanced model section.
Removed LED connections from ADT Ethernet bus description.
Added descriptions of LED blinking.
Specified a fixed Timeout_{ACK} in seconds for ADT TCP connections.
Deleted ADT UDP interconnect.
- 6 [Sixth revision](#) (9 July 2008)
Incorporated changes from 18 June 2008 teleconference, minutes in [T10/08-269r0](#).
Added definitions.
Modified layer figure.
Modified connection tables.
Added ladder diagrams for transport services.
Added background discussion of connection closing and I_T nexus loss.
Capitalize initial letters, per editor’s guidance.
- 7 [Seventh revision](#) (25 July 2008)
Incorporated changes from 14 July 2008 meeting, minutes in [T10/08-291r0](#).
Moved connection definitions into separate subclause from electrical characteristics.
Reorganized conventions subclauses to match SAM-4 and added a conventions subclause for ladder diagrams.
Revised ladder diagrams. (For connection establishment, used a single diagram with optional inter-device communication, rather than different diagrams for ADT serial and iADT ports as the working group had recommended.)
Changed terminology from ADT TCP interconnect port to iADT interconnect port.
Changed RS-422 references to match the actual number of the document (ANSI/EIA/TIA-422-B-

1994).

Defined that deassertion of the Sense_a or Sense_d connection may invoke the **Closed** service indication and added a reason argument to **Closed**.

See [T10/08-301r0](#) for a change to ADC-3 indicating that I_T nexus loss by bridging manager may be decoupled from command processing by local SMC device server.

8 [Eighth revision](#) (31 August 2008)

Incorporated changes from 13 August 2008 teleconference, minutes in [T10/08-329r0](#).

This revision does not address any of the questions raised by IBM's T10/08-332r0:

- Support for short-lived connections, i.e., not having connection loss cause I_T nexus loss.
- Specifying what to do if a connection cannot be established.
- Relevance of the Sense_a signal.
- Removing all references to Ethernet.
- Specifying signals to facilitate locating the drive in a library.

9 [Ninth revision](#) (6 October 2008)

Incorporated changes from 8 September 2008 meeting, minutes in [T10/08-372r0](#).

Deleted retirement to send a Close event to Port state machine upon connection close.

Removed requirement to have Sense_a/Sense_d asserted to establish a connection.

Incorporated comments from IBM's [T10/08-392r0](#) and from an IBM e-mail about the Sockets API. This includes a new informative subclause 6.4.6.

Renamed Close service request and Closed service indication to Disconnect and Disconnected.

Added ADT Port argument to protocol services to identify the ADT port.

Deleted service responses that are generated only in response to invalid requests, e.g., coding errors like NULL arguments. Added subclause 6.2.11 and Table w indicating possible causes of other errors and recovery procedures.

Deleted some of the detailed renumbering instructions; the editor is capable of doing this himself.

General

To allow future data transfer devices to have improved and alternate means to communicate with automation devices, Ethernet is proposed as an ADT port. One possible configuration would be an isolated subnet with the library controller and all drives attached. These ports will typically be 10/100BaseT, so there will be a great increase in bandwidth above the fastest existing RS422-based ADI ports.

Implementing an ADI Ethernet port could be done in two ways. One would be to use iSCSI to carry SCSI commands, data, and status and then to invent a new protocol for VHF data. A simpler approach would be to transport the entire ADT protocol over a networking protocol. This proposal is to do the latter, and is named Internet ADT (iADT).

A straightforward implementation of iADT would be to open a TCP connection between the automation device and the data transfer device. A TCP connection (also known as a stream) provides bi-directional reliable delivery of a stream of bytes. The existing ADT link layer protocol provides the necessary framing. While TCP error correction would prevent framing errors and parity errors from reaching the ADT layer, it would still be possible for acknowledgement timeouts to occur.

To avoid the need to modify ADT-2 to specify mapping of TCP connections to I_T nexuses, this proposal sidesteps the issue by stating that one ADT port connects to one other ADT port, without reference to the interconnect layer. At the interconnect layer, this proposal defines ADT interconnect ports through which ADT ports connect. There are two types of ADT interconnect ports, serial and Ethernet. One ADT serial port can connect only to one other ADT serial port, while multiple ADT Ethernet ports can connect to one another. Nevertheless, when ADT ports connect via ADT Ethernet ports, each ADT port can connect to only one other ADT port.

This organization of the standard avoids changes to the clauses for link, transport, and SCSI application layers.

Technical issues

The following are technical issues which must be considered in developing this proposal:

Timeouts

- After discussion in the May 2008 working group meeting, it was decided that the acknowledgement timeout should be used. While its use in detecting corrupted frames is not necessary when using TCP, it can still be used in recovering from a skip in frame numbers in at least one observed case. See the discussion below under ADT link layer analysis.

Negotiated Parameters

- Of the parameters in the Login IU, only Major/Minor Revision, Maximum Payload Size, and Maximum Ack Offset seem to be needed in iADT. Baud rate is unnecessary.

Port Numbers

- The original intent of this proposal was to use a fixed port number for the iADT port on both ends (sockets) of the TCP connection. A registered port number (4169) was obtained from the Internet Assigned Numbers Authority (IANA). However, existing Sockets implementations appear to dynamically assign the port number of the port performing a TCP active OPEN, so this requirement is relaxed. Instead, the only socket required to use 4169 is one in the device performing a passive OPEN (Listen). I.e, a DTD will do a passive OPEN on port 4169 and the library will connect to that port. Similarly, the library could do a passive OPEN on 4169 if it is desired for the DTDs to initiate the connection.
- If the network segment inside the library connects to a router that connects outside the library, then the drive can be protected by requiring the router not to pass packets with the iADT port number in either the Source Port or Destination Port field of the TCP header. Requiring the receiving end of a connection request to use the iADT port number will facilitate this protection.

I_T Nexuses and TCP Connections

- This revision of the proposal removes the concept of the socket, although those could still exist at a lower level in implementations. By keeping the current concept of an ADT port's connecting only with one other ADT port, the I_T nexus can now be defined explicitly in terms of the X_ORIGIN bit (as it is now) and implicitly in terms of the ADT port identifier. This means that there is no change from the current standard.
- There is a new case in the I_T nexus loss case list, for closing of the TCP connection while still logged in at the ADT level.
- There was a question whether the TCP ABORT could map to a device reset. David Black has since advised against this, saying "...an attempt to use this sort of TCP feature as a carrier of SCSI level function/semantics is not a good idea in general." Moreover, it is not clear (1) what events in a host already cause a TCP ABORT, and (2) whether the OS function to reset a storage device could be made to send an ABORT. Finally, RFC 793 specifies that an ABORT causes release of the TCB (control block), as does a CLOSE. This implies that an ABORT should also cause an I_T nexus loss.
- In the 18 June teleconference, there was discussion of avoiding having a TCP CLOSE on a connection carrying a bridged SCSI command cause an I_T nexus loss on the primary port. There is no requirement in ADC-3 that an ADT port's reporting an I_T nexus loss event to the ADI bridging manager should cause the termination of a command being processed by the local SMC device server. For that reason, I have left in place the mapping of I_T nexus to TCP connection.

Physical Layer

- This revision of the proposal separates the ADT port from the physical port.
- The actual physical layer mandates Ethernet autonegotiation without mentioning specific speeds.

Custom Connector

The working group decided not to pursue a standard connector to include Ethernet. Instead, an ADT Ethernet “bus” is specified to list those connections which would be mandatory and optional.

- 1000BaseT requires four pairs of wires; usually all are wired in RJ-45 connectors and in Ethernet cables. However, 10 and 100BaseT only require two pair, so we discard the other two. There is no forecast need for an ADT Ethernet port to support Gigabit Ethernet.
- The ADT Ethernet bus will include the ADT Sense_a line. Standalone DTDs may use Ethernet. Examples of how to discover presence in a library include a jumper or an extra pin on the Ethernet connector. If the DTD is not installed in a library, then it will enable its primary port(s) regardless of the saved setting of the port enable (PE) bit.
- In this revision of the proposal, support for the Reset_a connection is optional. In Ethernet, this will cause a re-initialization of the port, which would imply re-acquiring the IP address, re-establishing connections, etc.
- In this revision of the proposal, support for the Sense_d connection is optional.
- In this revision of the proposal, support is added for one or two LED connections to indicate Ethernet signal sense and activity. The connection will directly drive an LED which is pulled up via a resistor. The current and voltage characteristics of the connections are specified, but not those of the LED or resistor. This is intended to give designers maximum flexibility.
- The working group decided not to specify serial diagnostic connections in the ADT Ethernet bus

Discovery

- The working group wishes to specify how to discover the IP address of the library’s and DTD’s iADT ports.
- One possible means of discovery would be to use the Discovery and Description steps of the Universal Plug and Play (UPnP) protocol. This uses broadcast of UDP datagrams and does not require a server to track service locations. This would require the DTD to support an HTTP server. Proposal T10/08-198r0 describes how UPnP could be used. Discovery will not be a part of this proposal.

ADT link layer analysis

This section examines ADT’s link-level specification for areas that are irrelevant to iADT, including frame header fields, information units, and state machines. While the current revision of the proposal makes no changes to the link layer, this information is retained for reference.

Much of the error recovery in ADT is to detect and correct physical-layer corruption of frames; these can be corrected by retransmitting the corrupted frame and are termed recoverable errors. Other errors, such as specifying an invalid protocol, setting a reserved bit, and sending a too-long packet can be due to firmware errors at a higher level. Simple retransmission cannot fix these errors and they are termed unrecoverable. TCP’s reliable delivery will eliminate the recoverable errors, but cannot fix the unrecoverable errors.

State machines

The Transmitter Error and Receiver Error state machines are only used to recover from out of order or lost frames. TCP makes them unnecessary, and along with them the Initiate Recovery IUs.

Frame header fields

All of the frame header fields in ADT appear to be necessary in iADT. The following table summarizes the reasons.

Table 1 – Applicability of ADT frame header fields

Field	Comments
PROTOCOL	Needed to differentiate SCS Encapsulation, Fast Access, etc.
FRAME TYPE	Needed for various protocols
X_ORIGIN	Needed to distinguish exchanges originated by library from those originated by the DTD. This is effectively a part of the EXCHANGE ID field.
EXCHANGE ID	Needed to differentiate overlapped commands, etc.
FRAME NUMBER	Needed to associate ACKs and NAKs with frames.
PAYLOAD SIZE	Needed to help trap errors in frame assembly.

Timeouts

The original intent of the acknowledgement IU timeout in ADT was to recover from lost or corrupted (and thus discarded) frames. TCP should protect against both of these, so the only possible causes for this timeout would be slow processing in the receiver of the frame to be acknowledged or slow network transmission. However, a case was presented in which the acknowledgement timeout was used to recover from a malformed ACK IU. As a result, this revision of the proposal retains the acknowledgement timeout.

Link service IUs

Following is a summary of which ADT Link Service IUs are needed and which are not needed.

Table 2 – Applicability of ADT link service IUs

IU type	Comments
Login IU	Yes – Need a mechanism to agree on Major Revision, Minor Revision, Maximum Payload Size, and Maximum Ack Offset.
Logout IU	Yes – Need to provide logout duration and reason code.
Pause IU	No – If no receive() is performed on the connection, then data will not be lost. (This was originally intended to prevent dropping bytes on an RS-422 connection that was being ignored.)
NOP IU	No – Does anyone feel that this is needed?
Initiate Recovery IU	No – TE/RE state machines are not required.
Initiate Recovery ACK IU	No – TE/RE state machines are not required.
Initiate Recovery NAK IU	No – TE/RE state machines are not required.
Device Reset IU	Yes
Timeout IU	Yes
ACK IU	Yes – While the flow control function of the ACK IU may not be needed, it still serves the purpose of indicating that a frame did not have non-recoverable errors. See the discussion below of the NAK IU.
NAK IU	Yes – See the following discussion of status codes.

The NAK IU is necessary to report certain errors that are due to an incorrectly-assembled frame; they are not related to corrupted or out-of-order frames. All of these errors are non-recoverable, i.e., they cannot be fixed by retransmission. For example, the upper layer assembling the frame may exceed the

maximum payload length or may have a mismatch between the payload length field and the actual payload length.

Table 3 – Applicability of NAK IU status codes

Status code	Comments
OVER-LENGTH	Yes – This error can occur and cannot necessarily be corrected by retransmission.
UNDER-LENGTH	Yes – This error can occur and cannot necessarily be corrected by retransmission.
UNEXPECTED FRAME NUMBER	Yes – The ACK may be malformed.
AWAITING INITIATE RECOVERY IU	No
HEADER RESERVED BIT SET	Yes – This error can occur.
INVALID EXCHANGE ID	Yes – This error can occur.
UNSUPPORTED PROTOCOL	Yes – This error can occur.
OUT OF RESOURCES	Yes – This error can occur.
LOGIN IN PROGRESS	Yes – This error can occur.
INVALID OR ILLEGAL IU RECEIVED	Yes – This error can occur.
REJECTED, PORT IS LOGGED OUT	Yes – This error can occur
MAXIMUM ACK OFFSET EXCEEDED	Yes – This error can occur.
MAXIMUM PAYLOAD SIZE EXCEEDED	Yes – This error can occur.
UNSUPPORTED FRAME TYPE FOR SELECTED PROTOCOL	Yes – This error can occur.
NEGOTIATION ERROR	Yes – This error can occur
Vendor specific	Yes.

Editorial Notes

Paul Stone surveyed various T10 standards to determine how words in figures should be capitalized. The T10 style guide does not address this. Paul observed that the majority of standards capitalize initial letters, and requested that this proposal do likewise. Revision 6 incorporates this guidance; see also Revisions.

Revision 7 incorporates a conventions section for ladder diagrams. It also reorganizes the conventions section to more closely match that in SAM-4. However, it has retained the “state machine” terminology, while SAM-4 uses “state diagram.” See also Revisions.

Items Not Specified

The following technical issues have not been addressed in this proposal:

- While the maximum payload size decided on in ADT negotiation will continue to be driven by device resources, can it be kept independent of the TCP Maximum Segment Size (MSS), which is typically 1500 bytes in IPv4? An ADT frame split across multiple TCP segments might be handled inefficiently. (The MSS is the largest amount of data that can be sent in an unsegmented piece. The Maximum Transmission Unit (MTU) is the largest packet (header, data, and trailer) that can be sent. Because data is a component of a packet, MTU > MSS.)
- If a DTD is installed with both Ethernet and RS-422 ADI ports connected to the automation device, there could be confusion, although this would not be a new issue as currently nothing prohibits having two ADI ports. There is a practical issue, i.e., implementations may have taken shortcuts that would make the behavior of the ADC device server non-SAM-compliant with respect to multiple I_T nexuses. This is not a standards issue, and this proposal will not address the question of multiple ADI ports.
- Sockets APIs typically include an “out-of-band” channel that can be processed separately from regular data. This can be used to allow some data to bypass data sent earlier. This

feature is not specified in this proposal, as it has no clear advantages and could potentially cause problems.

Changes to ADT-2 rev. 5

Markup conventions

Proposed additions are in **blue**, removed text is in **crossed-out red**.

Editor's notes in **green** provide information on decisions to be made and actions to be performed before this proposal can be integrated into the standard.

Change to clause 2

Add the following subclauses:

2.1.4 IETF references

RFC 791, *Internet Protocol – DARPA Internet Program – Protocol Specification*

RFC 793, *Transmission Control Protocol (TCP) – DARPA Internet Program – Protocol Specification*

RFC 2460, *Internet Protocol, Version 6 (IPv6) Specification*

RFC 3493, *Basic Socket Interface Extensions for IPv6*

2.1.5 IEEE references

IEEE 802.3-2005, *Carrier sense multiple access with collision detection (CSMA/CD) access method and physical layer specifications*

2.2 Informative references

<...>

~~ANSI/TIA 422-B-1994 (R2000)~~ ANSI/EIA/TIA-422-B-1994 (revised January 27, 2000) Electrical Characteristics of Balanced Voltage Digital Interface Circuits. (RS-422)

Changes to clause 3

Add the following definition:

3.1.x LLC: link layer control.

3.1.x MAC: media access control.

3.1.x MDI: medium dependent interface.

3.1.x PHY: physical layer.

3.1.x PLS: physical signaling sublayer.

Reorganize clauses 3.4 through 3.6 as shown below and add a subclause for ladder diagram notation:

3.4 Conventions Editorial conventions

Certain words and terms used in this American National Standard have a specific meaning beyond the normal English meaning. These words and terms are defined either in clause 3 or in the text where they first appear. Names of signals, phases, messages, commands, statuses, sense keys, additional sense codes, and additional sense code qualifiers are in all uppercase (e.g., REQUEST SENSE), names of fields are in small uppercase (e.g., STATE OF SPARE), lower case is used for words having the normal English meaning.

Fields containing only one bit are usually referred to as the name bit instead of the name field.

~~Numbers that are not immediately followed by lower case b or h are decimal values.~~

~~Numbers immediately followed by lower case b (xxb) are binary values.~~

~~Numbers immediately followed by lower case h (xxh) are hexadecimal values.~~

~~Decimals are indicated with a comma (e.g., two and one half is represented as 2,5).~~

~~Decimal numbers having a value exceeding 999 are represented with a space (e.g., 24 255).~~

An alphanumeric list (e.g., a,b,c or A,B,C) of items indicates the items in the list are unordered.

A numeric list (e.g., 1,2,3) of items indicate the items in the list are ordered (i.e., item 1 shall occur or complete before item 2).

In the event of conflicting information the precedence for requirements defined in this standard is:

- 1) text,
- 2) tables, then
- 3) figures.

3.5 Numeric conventions

Numbers that are not immediately followed by lower-case b or h are decimal values.

Numbers immediately followed by lower-case b (xxb) are binary values.

Numbers immediately followed by lower-case h (xxh) are hexadecimal values.

Decimals are indicated with a comma (e.g., two and one half is represented as 2,5).

Decimal numbers having a value exceeding 999 are represented with a space (e.g., 24 255).

3.6 Notation conventions

~~3.5~~ 3.6.1 Notation for **P**rocedures and **F**unctions

<...>

~~3.6~~ 3.6.2 ~~State machine conventions~~ Notation for state machines

~~3.6.1~~ 3.6.2.1 ~~State machine conventions overview~~ Notation for state machines overview

<...>

~~3.6.2~~ 3.6.2.2 ~~sub-state~~ Sub-state machines

<...>

~~3.6.3~~ 3.6.2.3 Transitions

<...>

3.6.4 3.6.2.4 Messages, requests, and event notifications

<...>

3.6.3 Notation for communication sequence diagrams

Ladder diagrams are used to indicate communication among entities within a device and among devices. All communication sequence diagrams use the notation shown in Figure 3. Each entity is indicated by a horizontal bar with a label on top of a vertical bar. Entities within the same device are enclosed by a box with a label at the top of the box. Each communication is indicated by an arrow with an optional label. Solid arrows indicate mandatory communications and dashed arrows indicate optional communications. Time flows from the top of the diagram (i.e., first communication) to the bottom (i.e., last communication).

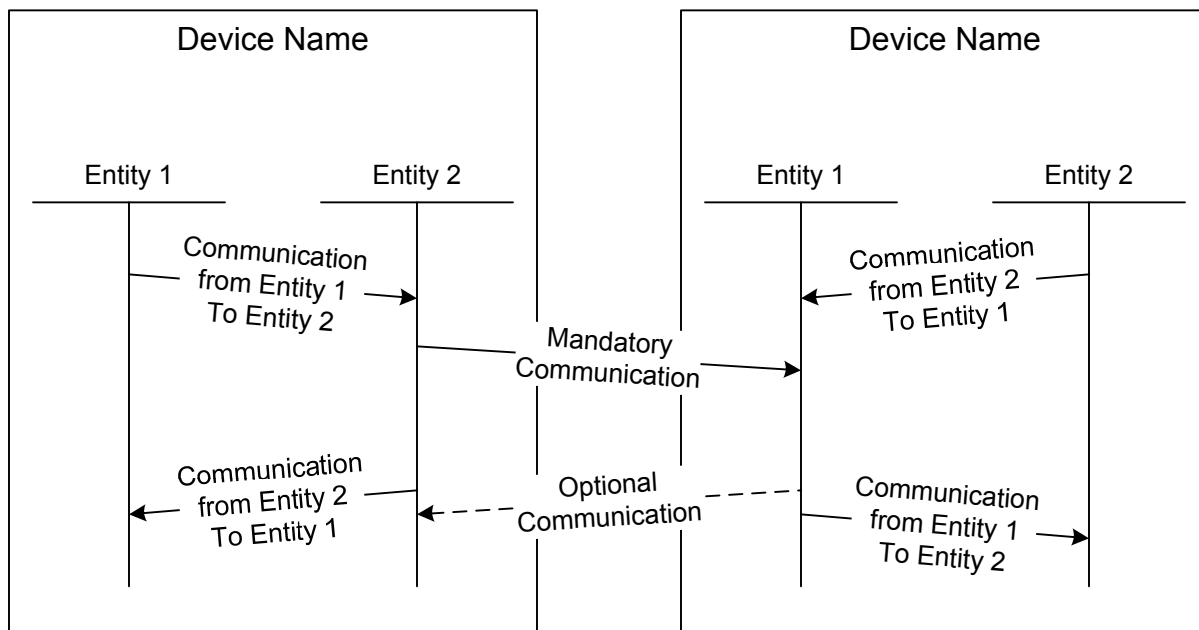

Figure 3 – Example communication sequence diagram

Changes to clause 4

Modify the beginning of clause 4.1:

4.1 Architecture

4.1.1 Architecture introduction

Figure 3 4 shows an example of an ADT interface within a media changer containing two DT devices. Other common components of a media changer are also shown for reference. The components of an automation device are medium transport elements, data transfer (DT) devices, storage elements, and import/export elements (see SMC-3). The automation device communicates with the DT devices through ADT ports, as defined in this standard. DT devices and automation devices communicate with initiator ports other than those in the automation device using primary ports.

[Figure 3 is renumbered to 4]

If ADI Bridging is enabled (see ADC-2), each ADT port in the DT device and automation device is a SCSI target/initiator port. If ADI Bridging is disabled, the DT device port is a SCSI target port and the automation device port is a SCSI initiator port.

Add the following at the end of clause 4.1:

4.1.2 ADT protocol layers

The ADT protocol defines communication between two ADT ports. The ADT protocol consists of five layers. These are the physical layer, the interconnect layer, the link layer, the transport layer, and the SCSI application layer. An ADT interconnect port implements the interconnect layer and the physical layer. An ADT port implements the transport layer and the link layer.

Figure 5 shows the communication between ADT ports and between ADT interconnect ports at the different layers of the protocol, from the physical layer to the SCSI application layer.

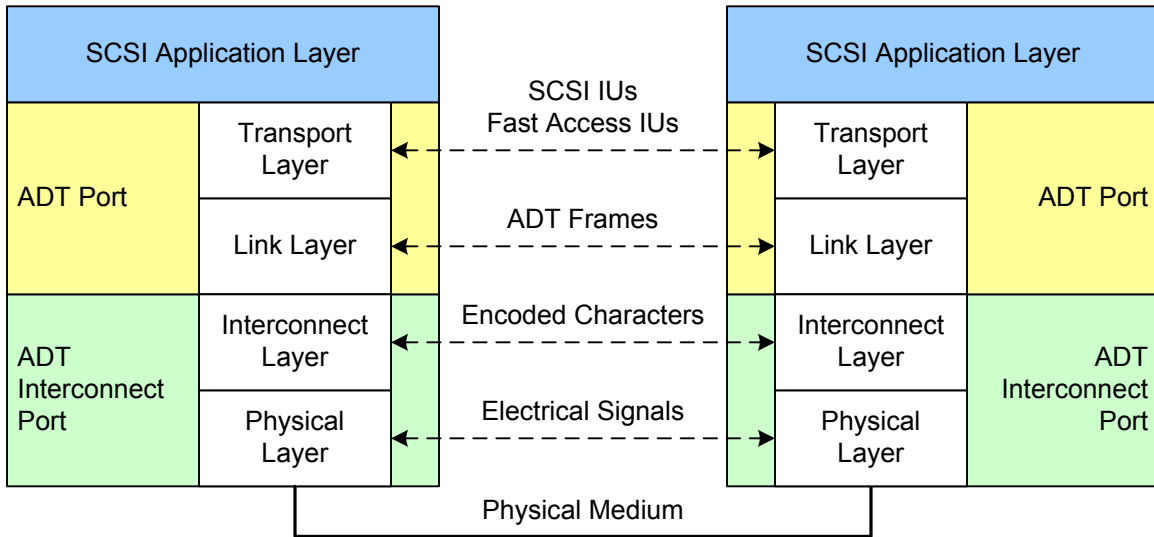

Figure 5 – ADT communication model

At the transport layer, information units (IUs) are passed between ADT ports. At the link layer, ADT frames are passed between ADT ports. At the interconnect layer, encoded characters are passed between ADT interconnect ports. At the physical layer, electrical signals are passed between ADT interconnect ports. The physical layers are connected by the physical medium.

Figure 6 shows the hierarchy of protocols which may be used to implement ADT on the RS-422 serial physical layer (see ANSI/EIA/TIA-422-B-1994 and 5.2.5.2).

ADT SCSI Encapsulation	ADT Fast Access	Transport Layer
ADT Link Layer		Link Layer
ADT Serial		Interconnect Layer
RS-422		Physical Layer

Figure 6 – ADT serial protocol hierarchy

Figure 7 shows the Internet ADT (iADT) hierarchy of protocols which may be used to implement ADT on the Ethernet physical layer (see IEEE 802.3-2005 and 5.2.5.3).

ADT SCSI Encapsulation	ADT Fast Access	Transport Layer
ADT Link Layer		Link Layer
iADT		Interconnect Layer
TCP		
IP		
Ethernet LLC		
Ethernet MAC		
Ethernet PHY		Physical Layer

Figure 7 – iADT protocol hierarchy

The ADT physical layer (see clause 5) provides two alternative physical connections for data, RS-422 and Ethernet, as well as sense, signal, and LED connections.

The ADT interconnect layer (see clause 6) provides transmission of encoded characters between ADT ports. Two alternative transmission methods are defined, ADT serial and iADT. The ADT serial protocol provides transmission over an RS-422 physical layer. The iADT protocol provides transmission over a TCP connection (see RFC 793). The TCP connection uses the Internet Protocol (IP) (see RFC 791 and RFC 2460) to provide transmission over an Ethernet physical layer.

The ADT link layer (see clause 7) provides reliable transmission of ADT frames between ADT ports. The ADT frames are represented as encoded characters.

The ADT transport layer (see clause 8) provides transmission of two categories of information units (IUs), SCSI encapsulation IUs and fast access IUs, between ADT ports. The information units are represented as ADT frames.

The SCSI application layer (see clause 9) provides transport protocol services for processing SCSI commands and task management requests.

The term ADT serial port refers to an ADT interconnect port using the ADT serial transmit-receive connections (see 5.2.5.2) and the ADT serial interconnect layer (see 6.3). A single ADT port may use an ADT serial port for connection with another device. Figure 8 shows connections corresponding to Figure 4. ADT port A is connected with ADT port B, and ADT port C is connected with ADT port D.

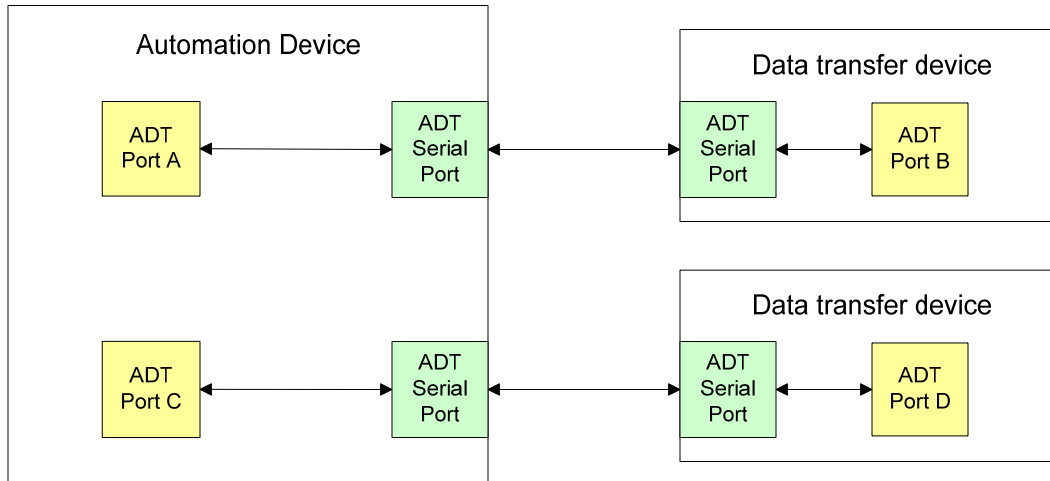

Figure 8 – ADT serial port example

The term iADT port refers to an interconnect port using Ethernet transmit-receive connections (see 5.2.5.3) and the iADT interconnect layer (see 6.4). Multiple ADT ports in one device may share a single iADT port for connection to other devices. Figure 9 shows two pairs of ADT ports connected by iADT ports, corresponding to the connections shown in Figure 4. ADT port A is connected to ADT port B, and ADT port C is connected to ADT port D.

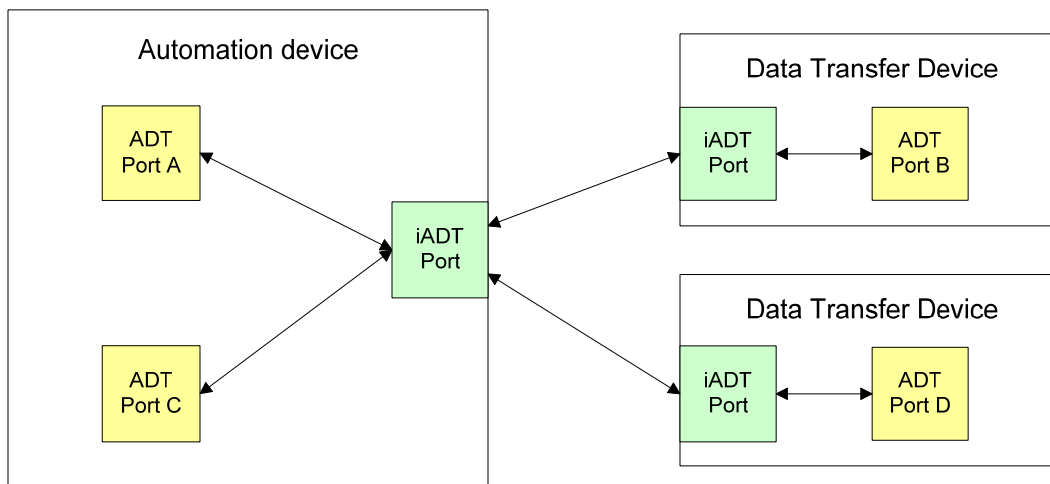

Figure 9 – iADT port example

4.8 I_T nexus loss

An I_T nexus loss event shall occur if an ADT port:

- a) sends a Port Login IU with the AOE bit set to one;
- b) receives a Port Login IU with the AOE bit set to one;
- c) receives an ACK IU in response to a Device Reset IU;
- ~~d) detects the change of state of the Sense line from presence to absence (i.e., Sense_a for DT device port and Sense_b for automation device port (see figure 11); or~~
- ~~e) detects the assertion of the Reset_a line (see table 13).~~
- d) receives a Reset service indication (see 6.6.10); or
- e) receives a Closed service indication while the Port State Machine is in either P1:Login or P2:Logged In state (see 6.3.2).

<...>

4.10.1 Acknowledgement time-out period calculation

When changing operating parameters (see 3.1.32), ~~a port~~ an ADT port connecting via an ADT serial port shall calculate a new acknowledgement IU time-out period using the formula in figure ~~9~~ 13. The port shall apply the new acknowledgement IU time-out period to every frame transmitted after changing operating parameters

Renumber Figure 9 to 15.

An ADT port connecting via an ADT Ethernet port shall use an initial acknowledgement time-out period of 2.5 seconds. This may be changed if the ADT port processes a time-out IU.

Changes to clause 5

5 Physical layer

5.1 Physical layer introduction

The ADT physical layer defines a number of connection types. Some of these connections are used by all ADT interconnect ports, some are used only by ADT serial ports, and some are used only by iADT ports. A connector is defined which may be used by ADT serial ports.

~~5.1~~ 5.2 Electrical characteristics

Renumber 5.1.1 through 5.1.4 to 5.2.1 through 5.2.4.

Modify Note 6 as follows:

NOTE 6 The connection specifications in sub clauses ~~5.1.3 through 5.1.5~~ 5.2.3, 5.2.4, and 5.2.5.2 assume cable with a $R < 400$ ohms/km, $Z_0 = 100$ ohms (nominal), and $C = 50$ pF/m (nominal).

Renumber Figure 10 to 16.

Modify clause 5.1.5 as follows:

~~5.1.5~~ 5.2.5 Transmit-receive ~~connection~~ connections

5.2.5.1 Transmit-receive connections introduction

This standard defines two sets of transmit-receive connections. The serial transmit-receive connection applies to implementations using the transmit-receive connections defined in 5.2.5.2. The Ethernet transmit-receive connection applies to implementations using Ethernet connections (see IEEE 802.3-2005).

5.2.5.2 Serial transmit-receive connections

A ~~serial~~ Transmit-Receive (Tx-Rx) connection is a complete simplex signal path from one ADT ~~serial~~ port to a second ADT ~~serial~~ port. A Tx-Rx connection includes:

- a) a signal generator connected to the output compliance point of one ADT ~~serial~~ port;
- b) a pair of transmission media from the output compliance point of one ADT ~~serial~~ port to the input compliance point of a second ADT ~~serial~~ port; and

c) a signal receiver connected to the input compliance point of the second ADT serial port.

A Tx-Rx connection shall conform to ~~TIA/EIA-422-B~~ ANSI/EIA/TIA-422-B-1994 as measured at the associated compliance points.

A Tx-Rx connection shall support 9 600 baud and may support the Modulation Rates listed in table 6.

A Tx-Rx connection shall use Non-return to Zero (NRZ) encoding of data bits to signaling elements. Hence, the data-signaling rate (in bps) equals the modulation rate (in baud).

A Tx-Rx connection shall transmit data bytes asynchronously adding one start bit, zero parity bits, and one stop bit to each data byte as depicted in figure ~~44~~ 17.

5.2.5.3 Ethernet transmit-receive connections

The electrical characteristics of Ethernet transmit-receive connections are defined in IEEE 802.3-2005.

Insert new clause 5.2.6:

5.2.6 LED connections

LED connections are used by a DT device to drive light-emitting diodes (LEDs) to indicate the status of the Ethernet connections. Table 7 describes the electrical characteristics of an LED connection at the output compliance point. The description assumes that:

- a) the output is an open-collector type;
- b) an LED and a resistor are connected in series between the output and the positive supply voltage.

Table 7 – LED connection output characteristics

Signal State	Current	Voltage
Asserted	$-25 \text{ mA} < I_{OL}$	$0 \text{ V} < V_{OL} < 0.4 \text{ V}$
Negated	$I_{OL} < 20 \text{ }\mu\text{A}$	$V_{OH} < 5.5 \text{ V}$

Insert new clause 5.3 Connection names:

5.3 Connection instances

5.3.1 Sense connection instances

Table 8 defines the sense connections used by ADT interconnect ports:

Table 8 — Sense connections

Connection Name	O/M ^a	Connection Type	Driven By	Connection Definition
Sense _a	M	Sense	automation device port	A DT device shall use this connection to sense the presence or absence of an automation device on the ADT bus.
Sense _{aux}	O	Sense		This standard does not define the use of this connection.
Sense _d	O	Sense	DT device port	An automation device shall use this connection to sense the presence or absence of a DT device on the ADT bus.

^a O indicates support is optional; M indicates support is mandatory.

5.3.2 Signal connection instances

Table 9 defines the signal connections used by ADT interconnect ports:

Table 9 — Signal connections

Connection Name	O/M ^a	Connection Type	Driven By	Connection Definition
Reset _a	O	Signal	automation device port	An automation device may use this connection to signal a reset request to a DT device by invoking the Reset service request. A DT device shall treat the receipt of a signal on this connection as an invocation of the Reset Received service indication in the ADT port attached to the ADT bus (see 6.6.10).
Signal _{aux}	O	Signal		This standard does not define the use of this connection.

^a O indicates support is optional; M indicates support is mandatory.

5.3.3 Serial transmit-receive connection instances

Table 10 defines the transmit-receive connections for ADT serial interconnect ports.

Table 10 – ADT serial transmit-receive connections

Connection Name	O/M ^a	Connection Type	Driven By	Connection Definition
Tx _a - Rx _d	M	Tx-Rx	automation device port	An automation device shall use this connection to send serialized data. A DT device shall receive serialized data on this connection.
Tx _d - Rx _a	M	Tx-Rx	DT device port	A DT device shall use this connection to send serialized data. An automation device shall receive serialized data on this connection.

^a O indicates support is optional, M indicates support is mandatory for ADT serial interconnect ports.

5.3.4 Ethernet transmit-receive connection instances

Table 11 defines the transmit-receive connections for iADT interconnect ports.

Table 11 – Ethernet transmit-receive connections

Connection Name	O/M ^a	Connection Type	Driven By	Connection Definition
TX_D1+	M	MDI ^b	^c	See IEEE 802.3-2005.
TX_D1-	M	MDI ^b	^c	See IEEE 802.3-2005.
RX_D2+	M	MDI ^b	^c	See IEEE 802.3-2005.
RX_D2-	M	MDI ^b	^c	See IEEE 802.3-2005.
BI_D3+	O	MDI ^b	^d	See IEEE 802.3-2005.
BI_D3-	O	MDI ^b	^d	See IEEE 802.3-2005.
BI_D4+	O	MDI ^b	^d	See IEEE 802.3-2005.
BI_D4-	O	MDI ^b	^d	See IEEE 802.3-2005.

Connection Name	O/M ^a	Connection Type	Driven By	Connection Definition
^a O indicates support is optional, M indicates support is mandatory for iADT interconnect ports. ^b Medium Dependent Interface (MDI) and alternate MDI (MDI-X) are defined in IEEE 802.3-2005. An MDI connection shall support autonegotiation of link speed. ^c In the MDI configuration, the port drives the TX_D1 pair. In the MDI-X configuration, the port drives the RX_D2 pair. ^d The BI_D3 and BI_D4 pairs are driven as indicated by IEEE 802.3-2005.				

5.3.5 LED connection instances

Table 12 defines the LED connections used by the DT device.

Table 12 – LED connections

Connection Name	O/M ^a	Connection Type	Driven By
LED _{active}	O	LED	DT device port
LED _{signal}	O	LED	DT device port
^a O indicates support is optional, M indicates support is mandatory.			

A DT device supporting both the LED_{signal} and LED_{active} connections may signal in the following manner:

- if carrier is detected (see IEEE 802.3-2005), the LED_{signal} connection is asserted. If no carrier is detected, the LED_{signal} connection is deasserted and the LED_{active} connection is deasserted; and
- if data is being transmitted or received on the TX_D1 or RX_D2 connections (see IEEE 802.3-2005), the LED_{active} connection is alternately asserted and deasserted. If no data is being received on the TX_D1 or RX_D2 connections, the LED_{active} connection is deasserted.

A DT device supporting only the LED_{signal} connection may signal in the following manner:

- if no carrier is detected, the LED_{signal} connection is deasserted;
- if carrier is detected and no data is being received on the TX_D1 and RX_D2 connections, the LED_{signal} connection is asserted; and
- if data is being received on the TX_D1 or RX_D2 connections, the LED_{signal} connection is alternately asserted and deasserted.

Renumber clause 5.2 Connector pin-out to 5.3.

5.3.5.4 Connector pin-out

ADT serial interconnect ports shall may use the plug connector defined in SFF-8054. Table 8 13 defines the pinout for the ADT port connector on the DT device.

Table 8 13 – DT device ADT serial port connector pinout

Pin Number	Connection Name	Reference
1	+Tx _a - Rx _d	Table 16
2	-Tx _a - Rx _d	Table 16
3	Ground	
4	-Tx _d - Rx _a	Table 16
5	+Tx _d - Rx _a	Table 16
6	Sense _d	Table 3
7	Sense _a	Table 3

8	Reset _a	Table 7
9	Signal _{aux}	Table 7
10	Sense _{aux}	Table 7

No connector pin-out is defined for the use of iADT ports.

New clause 6

Insert a new clause 6 between 5 (Physical layer) and 6 (Link layer):

6 Interconnect layer

6.1 Interconnect layer introduction

The ADT interconnect layer provides protocol services for transmitting and receiving sequences of encoded characters between ADT ports. Table 14 summarizes the ADT interconnect layer protocol services.

Table 14 – ADT interconnect layer protocol services

Protocol service	Interconnect service protocol interaction	Invoked by
Listen	Request	Either
Connect	Request	Either
Connected	Indication	Either
Send	Request	Either
Receive	Request	Either
Received	Indication	Either
Disconnect	Request	Either
Disconnected	Indication	Either
Reset	Request	Automation device
Reset received	Indication	DT device

The **Sense** protocol service determines whether the Sense_a connection (in a DT device) or the Sense_d connection (in an automation device) is asserted.

Figure 18 shows the relationships among the protocol services used to establish a connection between two ADT serial ports. When closing a connection, no communication takes place between the devices.

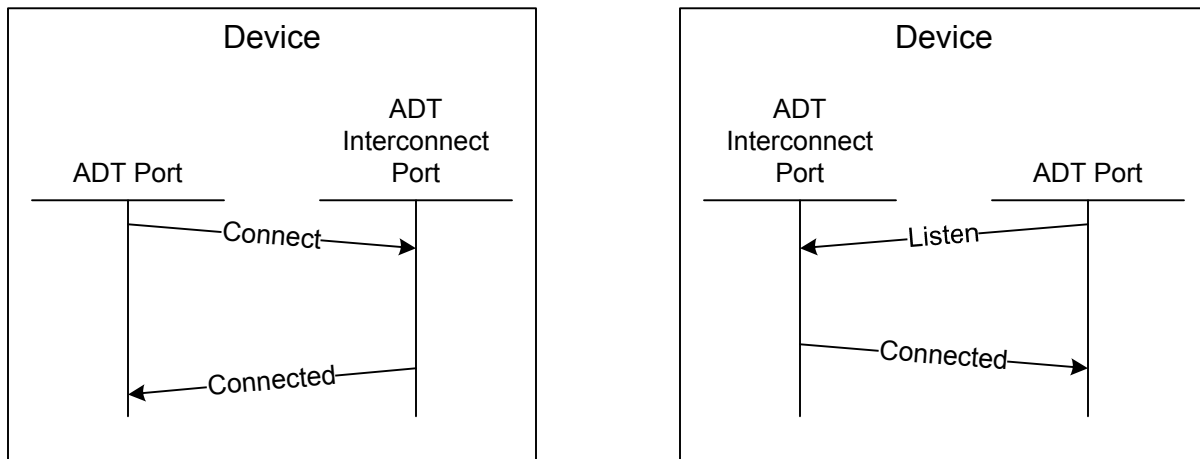

Figure 18 – Protocol services for establishing a connection between ADT serial ports

Figure 18a shows the relationships among the protocol services used to establish a connection between two iADT ports. The communication between the two devices is defined in RFC 793 and may constitute more than the two communications shown.

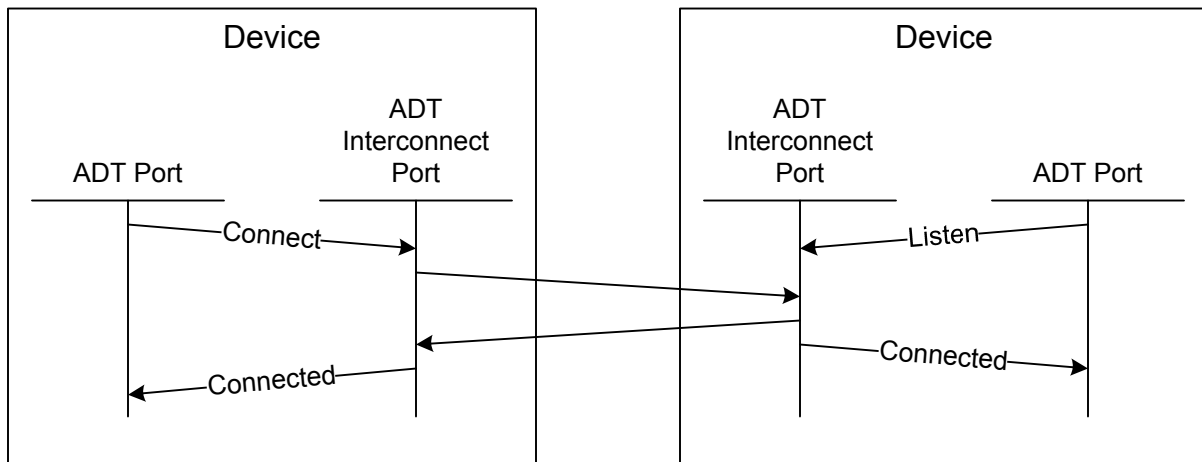

Figure 18a – Protocol services for establishing a connection between iADT ports

An ADT port may either initiate a connection to a specific interconnect port, or await a connection from any interconnect port. An ADT port initiates a connection by invoking the **Connect** service request. An ADT port awaits a connection by invoking the **Listen** service request. When the connection is established, both ADT ports receive a **Connected** service indication. The ADT interconnect ports may exchange information in order to establish the connection. To establish a connection ADT serial interconnect ports do not exchange information and iADT interconnect ports do exchange information.

NOTE n A connection is always considered to exist between a pair of ADT serial interconnect ports when the $Sense_a$ signal is asserted. For that reason, an ADT serial interconnect port invokes the **Connected** service indication immediately following the successful invocation of the **Connect** or **Listen** service request by the ADT port. The **Connected** service request may fail if the Sense connection is deasserted.

Figure 19 shows the relationships among the protocol services used to transfer data.

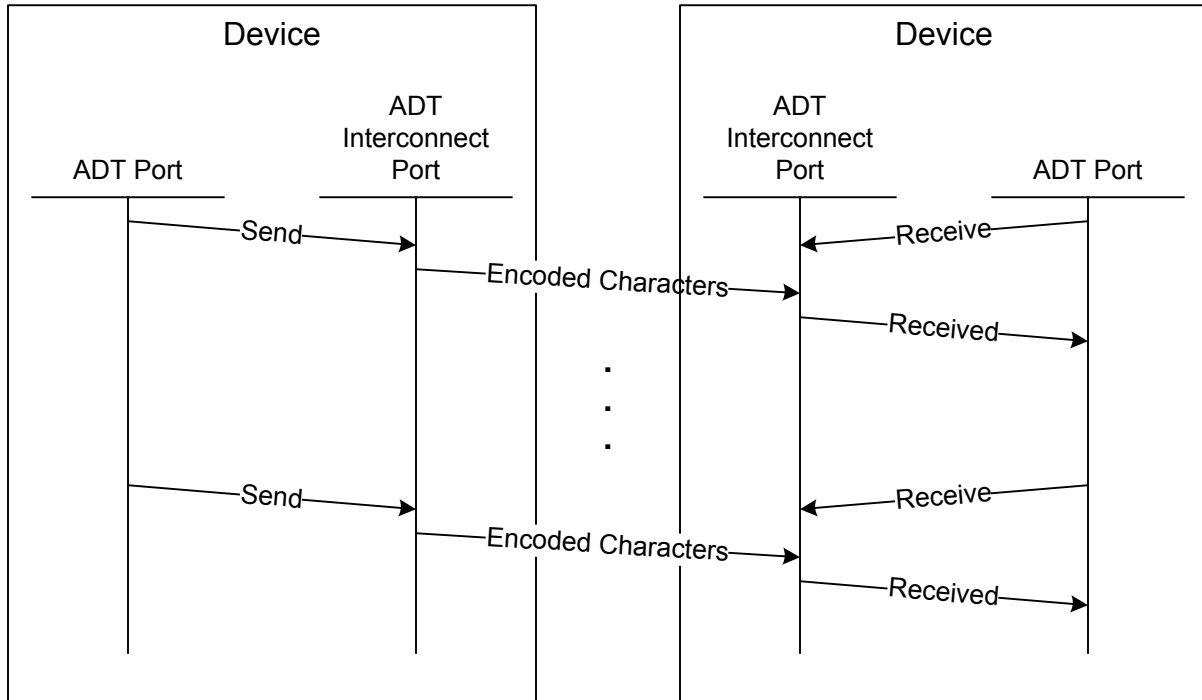

Figure 19 – Protocol services for transferring data

An ADT port sends encoded characters on a connection by invoking the **Send** service request. The **Send** service request specifies the connection, the buffer containing the characters to be sent, and the number of characters to be sent. When the **Send** service request completes, the characters have been accepted by the interconnect port for delivery.

An ADT port receives encoded characters on a connection by invoking the **Receive** service request and then processing the **Received** service indication. The **Receive** service request specifies the connection, the buffer to contain the received characters, and the maximum number of characters to be placed in the buffer. When characters have been placed in the buffer, the **Received** service indication is invoked. The **Received** service indication indicates the number of characters that have been placed in the buffer. To receive more characters on the connection, the ADT port must invoke the **Receive** service request again.

Figure 20 shows the relationships among the protocol services used to close a connection between two ADT serial ports. When closing a connection, no communication takes place between the devices.

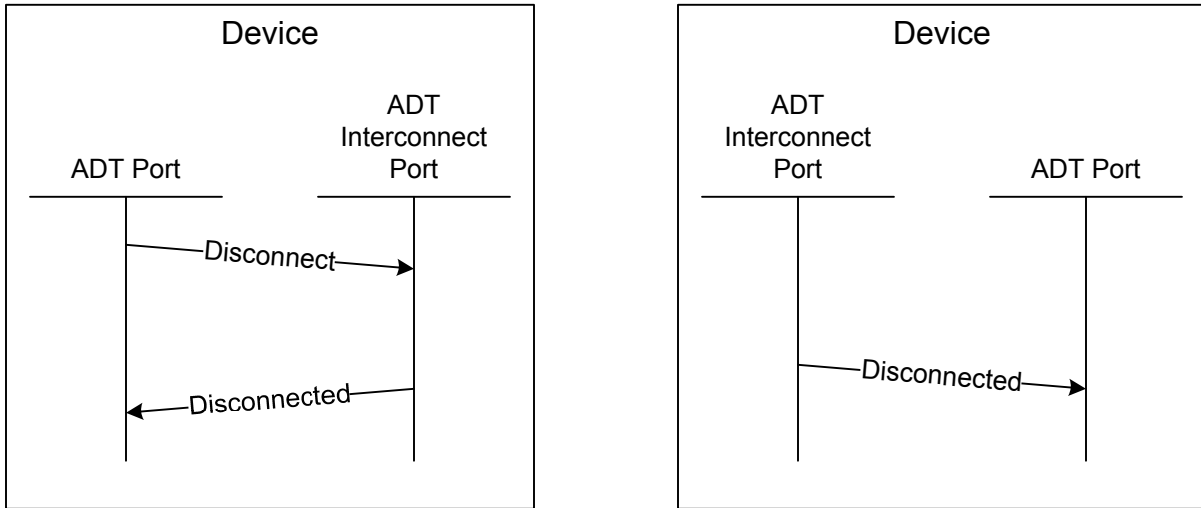

Figure 20 – Protocol services for closing a connection between ADT serial ports

Figure 20a shows the relationships among the protocol services used to close a connection between two iADT ports. The communication between the two devices is defined in RFC 793 and may constitute more than the two communications shown.

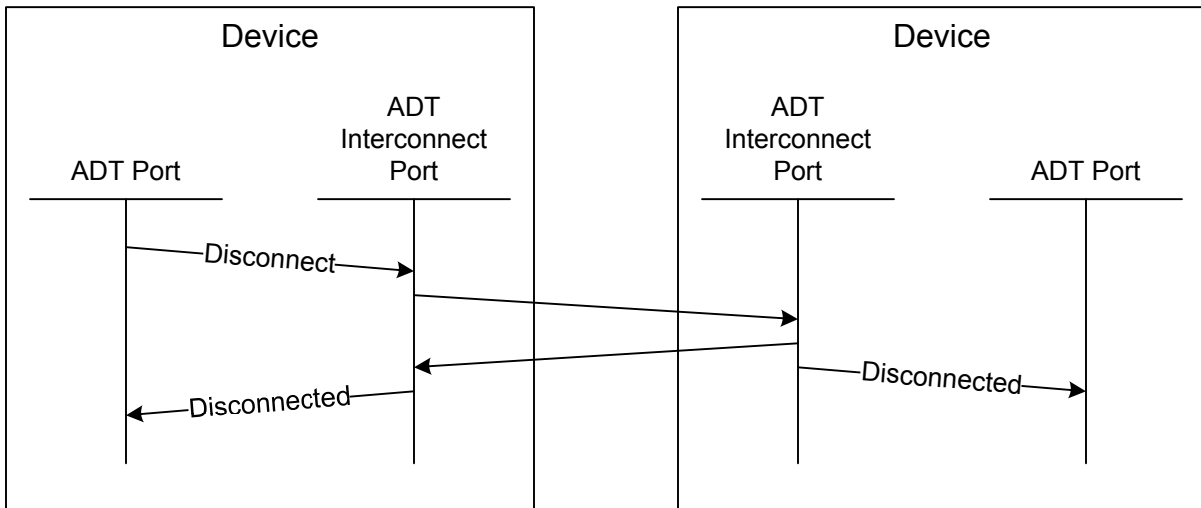

Figure 20a – Protocol services for closing a connection between iADT ports

An ADT port closes a connection by invoking the **Disconnect** service request. Any characters that have been submitted for delivery by earlier **Send** service requests will be transmitted before the connection is closed. When an ADT port receives a **Disconnected** service indication, the connection is closed and no more characters shall be received. The ADT connection ports may or may not exchange information in order to close the connection. To close a connection ADT serial interconnect ports do not exchange information and iADT interconnect ports do exchange information.

Figure 21 shows the relationships among the protocol services used to perform a reset.

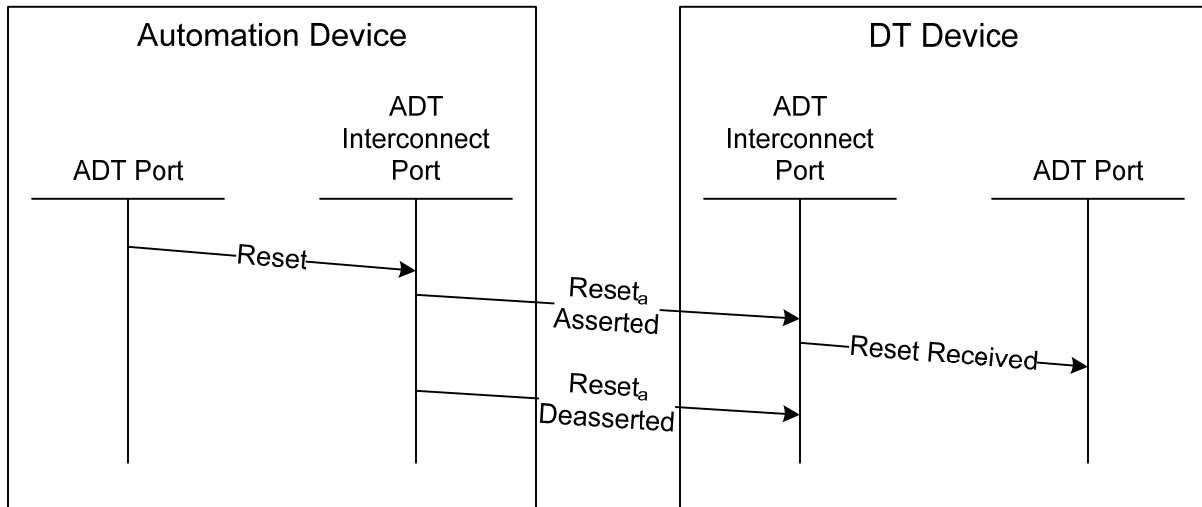

Figure 21 - Protocol services for performing a reset

An ADT port in an automation device resets an ADT port in a DT device by invoking the **Reset** service request. The ADT port then asserts the Reset_a connection. Assertion of the Reset_a connection causes the ADT port in the DT device to receive a **Reset received** service indication.

6.2 Interconnect layer protocol service definitions

6.2.1 Connect service request

An ADT port uses the **Connect** protocol service request to initiate a connection between a local interconnect port and a specific remote interconnect port. One ADT port may establish not more than one concurrent connection.

An ADT port shall not invoke the **Connect** service request on a local port after it has invoked the **Listen** service request on that port.

Service Response = Connect (IN (ADT Port, Local Port, Remote Port))

Input arguments:

- ADT Port:** An identifier for the ADT port invoking the service request.
- Local Port:** An identifier for the local interconnect port.
- Remote Port:** The identifier for the remote interconnect port. This argument shall be ignored by an ADT serial port.

Service Response assumes one of the following values:

- GOOD:** The request completed successfully.
- INVALID REMOTE PORT:** The request failed because the **Remote Port** argument did not specify a valid remote interconnect port.
- CONNECTION REFUSED:** The request failed because the **Remote Port** did not accept the connection. This service response shall be reported if no ADT port had performed a **Listen** service request on the remote interconnect port.
- NO PHYSICAL CONNECTION:** The request failed because the Sense connection was not asserted.

6.2.2 Listen service request

An ADT port uses the **Listen** protocol service request to await a connection. One ADT port may await one connection on a local ADT serial port. Multiple ADT ports may await one connection each on a local ADT Ethernet port.

An ADT port shall not invoke the **Listen** service request on a local port after it has invoked the **Connect** service request on that port.

If the Sense_a connection in a DT device or the Sense_d connection in an automation device is deasserted, then the **Listen** service request may return a service response of **NO PHYSICAL CONNECTION**.

Service Response = Listen (IN (ADT Port, Local Port))

Input arguments:

ADT Port: An identifier for the ADT port invoking the service request.

Local Port: An identifier for the local interconnect port

Service Response assumes one of the following values:

GOOD: The request completed successfully. This may be reported if the Sense connection is not asserted.

NO PHYSICAL CONNECTION: The request failed because the Sense connection was not asserted.

6.2.3 Connected service indication

An interconnect port uses the **Connected** service indication to notify the ADT port that the requested connection has been established. The **Connected** service indication shall not be invoked if the ADT port has not invoked either a **Connect** or a **Listen** service request.

Connected (IN (ADT port, Connection, Remote Port))

Input arguments:

ADT Port: An identifier for the ADT port receiving the service indication.

Connection: The identifier for the connection.

Remote Port: The identifier for the remote interconnect port.

6.2.4 Send service request

An ADT port uses the **Send** service request to send data on a connection. If a subsequent **Send** service request is invoked before all of the data in the buffer specified by a previous **Send** service request, then all of the data in the buffer for the previous invocation shall be sent before any data in the buffer of the subsequent invocation is sent.

If the **Send** service request returns a service response of **OK**, then the contents of the buffer may be modified without affecting the data to be transmitted.

When the **Send** service request returns a service response of **OK**, then the characters may or may not have been transmitted on the physical connection.

Service Response = Send (IN (Connection, Buffer, Buffer Size))

Input arguments:

Connection: The identifier for the connection.

Buffer: A buffer containing data to be transmitted. The data in the buffer shall be encoded (see 7.2).

Buffer Size: The number of characters of encoded data to be transmitted on the connection.

Service Response assumes one of the following values:

GOOD: The request completed successfully.

OUT OF RESOURCES: The request failed because the interconnect port lacked resources to accept more characters for transmission.

6.2.5 Receive service request

An ADT port invokes the **Receive** service request to receive data from a connection. The data received shall be processed as specified in clause 7.

If the **Receive** service request is invoked a second time before the **Received** service indication has been invoked, then the second **Receive** service request shall be rejected with a service response of **RECEIVE PENDING**.

Service Response = Receive (IN (Connection, Buffer, Buffer Size))

Input arguments:

Connection: The identifier for the connection.

Buffer: A buffer to contain received data.

Buffer Size: The maximum number of characters of encoded data to be placed in the buffer.

Service Response assumes one of the following values:

GOOD: The request completed successfully.

INVALID CONNECTION: The request failed because the **Connection** argument did not specify an established connection.

RECEIVE PENDING: The request failed because the ADT port has invoked the **Receive** service request and the interconnect port has not yet invoked the **Received** service indication.

6.2.6 Received service indication

The **Received** service indication notifies the ADT port that a number of characters have been received.

There is not a one-to-one correspondence between invocations of **Send** in one ADT port and invocations of **Received** in the other ADT port, i.e., the characters delivered in one invocation of **Received** may have been sent by one or more invocations of **Send**. Similarly, the characters sent in one invocation of **Send** may be delivered in one or more invocations of **Received**.

Received (IN (ADT Port, Connection, Buffer, Received Character Count))

Input arguments:

ADT Port: An identifier for the ADT port receiving the service indication.

Connection: The identifier for the connection.

Buffer: A buffer containing data received. The data in the buffer shall be encoded (see 7.2).

Received Character Count: The number of characters received and placed in the buffer.

6.2.7 Disconnect service request

An ADT port invokes the **Disconnect** service request to close a connection.

If the **Send** service request is invoked after the **Close** service request, then the **Send** service request shall be rejected with a service response of **INVALID CONNECTION**.

Service Response = Disconnect (IN (ADT Port, Connection))

Input arguments:

Connection: The identifier for the connection.

Service Response assumes one of the following values:

GOOD: The request completed successfully.

INVALID CONNECTION: The request failed because the **Connection** argument did not specify an established connection.

6.2.8 Disconnected service indication

The **Disconnected** service indication notifies the ADT port that the connection has been closed. The **Received** service indication shall not be invoked after the **Disconnected** service indication has been invoked and before the **Connected** service indication has been invoked.

If an interconnect port in a DT device detects the transition of the Sense_a connection from asserted to deasserted, it may invoke the **Disconnected** service indication. If an interconnect port in an automation device detects the transition of the Sense_d connection from asserted to deasserted, it may invoke the **Disconnected** service indication.

Disconnected (IN (ADT Port, Connection, Reason))

Input arguments:

ADT Port: An identifier for the ADT port receiving the service indication.

Connection: The identifier for the connection.

Reason: The reason that the connection was closed.

Reason assumes one of the following values:

DISCONNECT REQUESTED: The ADT serial port processed a **Disconnect** service request.

CLOSED STATE: The iADT port detected loss of the TCP connection (see RFC 793).

SENSE DEASSERTED: The interconnect port detected transition of the Sense_a connection from asserted to deasserted.

6.2.9 Reset service request

An ADT port in an automation device uses the **Reset** service request to reset the ADT interconnect port and assert the Reset_a connection (see table 9).

Reset (IN (Local Port, Remote Port))

Local Port: An identifier for the local interconnect port.

Remote Port: The identifier for the remote interconnect port.

6.2.10 Reset received service indication

The **Reset received** service indication in a DT device indicates that the ADT interconnect port has been reset by assertion of the `Reseta` connection (see table 9).

Reset received (IN (ADT Port, Local Port))

ADT Port: An identifier for the ADT port receiving the service indication.

Local Port: An identifier for the local interconnect port.

6.2.11 Error recovery

Table w indicates possible causes for service responses other than **GOOD** and possible recovery procedures.

Table w – Service response error indication processing

Service response	Cause	Recovery procedure
INVALID REMOTE PORT	Remote port was disabled	Create new connection
CONNECTION REFUSED	Remote port was not ready for connection	Retry connection
NO PHYSICAL CONNECTION	Physical interface problem	Not specified by this standard
OUT OF RESOURCES	Local port has not sent previous data	Retry send after a delay
INVALID CONNECTION	Connection was closed	Create new connection and retry operation
RECEIVE PENDING	The ADT port has invoked the Receive service request and the interconnect port has not yet invoked the Received service indication.	Retry Receive service request after processing Received service indication

6.3 ADT serial port support of link layer protocol services

6.3.1 Connection establishment

When an ADT port invokes either the **Connect** or the **Listen** service request, the connection is considered to be established immediately. Invocation of either service request shall cause no transmission of data on the physical link. When either service request is invoked, the interconnect port shall invoke the **Connected** service indication. The **Connected** service indication may be invoked before the **Connect** or **Listen** service request has returned.

The ADT serial port shall support only one connection.

Table x shows how the arguments to the **Connect** service request are used by the ADT serial port.

Table x – Connect service request usage by ADT serial port

Argument	ADT serial implementation
ADT Port	Ignored
Local Port	Used to select the interconnect port
Remote Port	Ignored

Table x+1 shows how the arguments to the **Listen** service request are used by the ADT serial port.

Table x+1 – Listen service request usage by ADT serial port

Argument	ADT serial implementation
ADT Port	Identifier for the ADT port invoking the service request
Local Port	Used to select the interconnect port

Table x+2 shows how the argument to the **Connected** service indication is set by the ADT serial port.

Table x+2 – Connected service indication usage by ADT serial port

Argument	ADT serial implementation
ADT Port	Identifier for the ADT port receiving the service indication
Connection	Ignored
Remote Port	Ignored

6.3.2 Data transmission

Table x+3 shows how the arguments to the **Send** service request are used by the ADT serial port.

Table x+3 – Send service request usage by ADT serial port

Argument	ADT serial implementation
Connection	Assigned by the interconnect port and used by subsequent service requests and indications
Buffer	The buffer containing data to be transmitted
Buffer Size	The number of characters in the buffer to be sent. The characters are encoded, i.e., the number includes Escape characters

6.3.3 Data reception

Table x+4 shows how the arguments to the **Receive** service request are used by the ADT serial port.

Table x+4 – Receive service request usage by ADT serial port

Argument	ADT serial implementation
Connection	Assigned by the interconnect port and used by subsequent service requests and indications
Buffer	The buffer to contain received data
Buffer Size	The maximum number of characters to be placed in the buffer

Table x+5 shows how the arguments to the **Received** service indication are set by the ADT serial port.

Table x+5 – Received service indication usage by ADT serial port

Argument	ADT serial implementation
ADT Port	Identifier for the ADT port receiving the service indication
Connection	Assigned by the interconnect port and used by subsequent service requests and indications
Buffer	The buffer containing the received data. The buffer shall be the same buffer specified in the previous invocation of the Receive service request.
Buffer Size	The number of characters placed in the buffer

6.3.4 Closing a connection

When an ADT port successfully invokes the **Disconnect** service request:

- a) the interconnect port shall transmit all characters which had been delivered to the ADT serial port by previous invocations of the **Send** service request which completed successfully;
- b) the ADT serial port may discard any characters received on the physical connection after the invocation of the **Disconnect** service request; and
- c) if any characters have been received by the ADT serial port and not yet transferred to the ADT port, then the ADT serial port shall accept **Receive** service requests and invoke the **Received** service indication until all received characters have been transferred.

When all characters received on the ADT serial port have been transferred to the ADT port, then the ADT serial port shall invoke the **Disconnected** service indication. The **Disconnected** service indication may be invoked before the **Disconnect** service request completes.

Table x+6 shows how the argument to the **Disconnect** service request is set by the ADT port.

Table x+6 – Disconnect service request usage by ADT serial port

Argument	ADT serial implementation
Connection	The value of the Connection argument returned by the Connected service indication

Table x+7 shows how the argument to the **Disconnected** service indication is set by the ADT serial port.

Table x+7 – Disconnected service indication usage by ADT serial port

Argument	ADT serial implementation
ADT Port	Identifier for the ADT port receiving the service indication
Connection	The value of the Connection argument returned by the Connected service indication
Reason	Either CLOSE REQUESTED or SENSE DEASSERTED .

6.3.5 Performing a reset

An automation device shall invoke the **Reset** service request to reset the ADT port in a DT device. Table x+8 shows how the argument to the **Reset** service request is used by the ADT serial port.

Table x+8 – Reset service request usage by ADT serial port

Argument	ADT serial implementation
Local Port	Used to select the interconnect port in the automation device to transmit the reset to the DT device
Remote Port	Identifier for the remote interconnect port receiving the reset.

A DT device shall treat the invocation of the **Reset received** service indication either:

- a) as a port logout (see 7.5.5); or
- b) as a hard reset (see 4.7).

Table x+9 shows how the argument to the **Reset received** service indication is set by the ADT serial port.

Table x+9 – Reset received service indication usage by ADT serial port

Argument	ADT serial implementation
ADT Port	Identifier for the ADT port receiving the service indication
Local Port	Indicates the DT device interconnect port which received the reset from the automation device interconnect port

6.4 iADT port support of link layer protocol services

6.4.1 Connection establishment

When an ADT port invokes the **Connect** service request, an iADT port shall perform an active **OPEN** call (see RFC 793) to the remote interconnect port whose IP address is specified in the **Remote Port**

argument and using a remote port number of 4169. The means by which the iADT port learns the IP address of the remote interconnect port is beyond the scope of this standard.

When an active **OPEN** call has successfully completed, each iADT port shall invoke the **Connected** service indication to its corresponding ADT port.

The iADT port may support more than one connection.

Table y shows how the arguments to the **Connect** service request are used by the iADT port.

Table y – Connect service request usage by iADT port

Argument	iADT port implementation
ADT Port	Used to identify the ADT port requesting the connection
Local Port	local port argument to the OPEN call
Remote Port	IP address component of the foreign socket argument to the OPEN call

When an ADT port invokes the **Listen** service request, an iADT port shall perform a passive **OPEN** call on the local ADT interconnect port specified in the **Local Port** argument.

Table y+1 shows how the arguments to the **Listen** service request are used by the iADT port.

Table y+1 – Listen service request usage by iADT port

Argument	iADT port implementation
ADT Port	Identifier for the ADT port invoking the service request
Local Port	local port argument to the OPEN call

Table y+2 shows how the argument to the **Connected** service indication is set by the iADT port.

Table y+2 – Connected service indication usage by iADT port

Argument	iADT port implementation
Connection	Connection identifier returned by the Connect service request
Remote Port	The identifier for the remote port, i.e., IP address and IP port number.

6.4.2 Data transmission

When the Send service request is invoked, the iADT port shall invoke the **SEND** call (see RFC 793) with the **PUSH flag** argument set. Table y+3 shows how the arguments to the **Send** service request are used by the iADT port.

Table y+3 – Send service request usage by iADT port

Argument	iADT port implementation
Connection	Connection identifier returned by the Connect service request
Buffer	buffer address argument to SEND call
Buffer Size	byte count argument to SEND call

6.4.3 Data reception

Table y+4 shows how the arguments to the **Receive** service request are used by the iADT port.

Table y+4 – Receive service request usage by iADT port

Argument	iADT port implementation
Connection	Connection identifier returned by the Connect service request
Buffer	buffer address argument to RECEIVE call

Buffer Size	byte count argument to RECEIVE call
--------------------	---

Table y+5 shows how the arguments to the **Received** service indication are used by the iADT port.

Table y+5 – Received service indication usage by iADT port

Argument	iADT port implementation
ADT Port	Identifier for the ADT port receiving the service indication
Connection	Connection identifier returned by the Connect service request
Buffer	buffer address argument to RECEIVE call
Buffer Size	The number of characters placed in the buffer

6.4.4 Closing a connection

When an ADT port successfully invokes the **Disconnect** service request, then the iADT port shall invoke the **CLOSE** call (see RFC 793). TCP guarantees that characters previously transferred with the **SEND** call shall be delivered before the connection is closed.

Table y+6 shows how the argument to the **Disconnect** service request is used by the iADT port.

Table y+6 – Disconnect service request usage by iADT port

Argument	iADT port implementation
Connection	The value of the Connection argument returned by the Connected service indication

When an iADT port enters the CLOSED state (see RFC 793), it shall invoke the **Disconnected** service indication. Table y+7 shows how the argument to the **Disconnected** service indication is set by the iADT port.

Table y+7 – Disconnected service indication usage by iADT port

Argument	iADT port implementation
ADT Port	Identifier for the ADT port receiving the service indication
Connection	The value of the Connection argument returned by the Connected service indication
Reason	Either CLOSED STATE or SENSE DEASSERTED

6.4.5 Performing a reset

An automation device shall invoke the **Reset** service request to reset the ADT port in a DT device. Table y+8 shows how the argument to the **Reset** service request is used by the iADT port.

Table y+8 – Reset service request usage by iADT port

Argument	iADT implementation
Local Port	Used to select the interconnect port in the automation device to transmit the reset to the DT device
Remote Port	Identifier for the remote interconnect port receiving the reset.

A DT device shall treat the invocation of the **Reset received** service indication either:

- a) as a **Disconnected** service indication (see 6.2.8) and may open a new connection; or
- b) as a hard reset (see 4.7).

Table y+9 shows how the argument to the **Reset received** service indication is set by the iADT port.

Table y+9 – Reset received service indication usage by iADT port

Argument	iADT implementation
ADT Port	Identifier for the ADT port receiving the service indication
Local Port	Indicates the DT device interconnect port which received the reset from the automation device interconnect port

6.4.6 Relationship to Sockets API (informative)

In TCP/IP implementations, the TCP calls mentioned above are typically invoked via a Sockets application programming interface (API). The details of the Sockets API varies between implementations. This subclause describes the typical semantics of the Sockets API function calls and how the link layer protocol services may be mapped to those function calls.

Table y+10 describes the function calls in a typical Sockets API.

Table y+10 – Sockets API function calls

Function	Description
socket()	Creates a socket descriptor that represents a communication endpoint. The arguments to the socket() function tell the system which protocol to use, and what format address structure will be used in subsequent functions
bind()	Assigns a name to an unnamed socket that represents the address of the local communications endpoint, i.e., IP address and port number. When a socket is created with socket(), it exists in a name space (address family), but has no name assigned. bind() requests that name be assigned to the socket.
connect()	Assigns the name of the remote communications endpoint and a connection is established between the endpoints.
listen()	Enables the socket to accept a specified number of connection requests from remote sockets. Up to that number of requests may be queued on the socket; if additional requests are received before a queued request is removed, then the additional requests are rejected. When an accept() is invoked on a socket with queued requests, then one request is removed and an additional request may be queued.
accept()	Accepts a connection request on a socket that is listening for connections. A queued request is removed from the socket, a new socket is created for the connection, which is defined by a remote IP address and port number and the local IP address and port number. Further packets on that connection are routed to the new socket. The original socket may be used to accept additional connection requests. If no connection request is queued on the original socket, then the accept() blocks until one arrives or until a close() is invoked on the socket.
send()	Sends outgoing data on a connected socket.
recv()	Receives incoming data that has been received by a connected socket.
shutdown()	Closes a connection and deletes the socket descriptor after all pending packets have been transmitted. If the deleted socket was the one upon which the listen() was invoked, then no new connections can be accepted. Existing connections are unaffected.
close()	Deletes a socket descriptor created by the socket() function. If the socket was connected, the connection is terminated. Data that has yet to be delivered to the remote endpoint is discarded. To ensure transmission and reception of all pending packets, close() should be invoked after shutdown() has returned.

If the deleted socket was the original one upon which the listen() was invoked, then no new connections can be accepted. Existing connections are unaffected.

Table y+11 shows how link layer service requests and service indications may be mapped to Sockets API function calls. The **Reset** service request and **Reset received** service indication are not listed because they are not relevant to the Sockets API.

Table y+11 – Protocol service mapping to Sockets API functions

Service Request/Indication	Socket function	Notes
Connect	socket()	
	bind()	bind() specifies a dynamic local port number.
	connect()	connect() specifies the remote socket address. This socket may not be reused for additional connections. Creating another connection requires invoking socket() to allocate a new socket resource and then invoking bind() and connect() on that new socket.
Listen	[socket()]	socket() is invoked if no prior Listen service request has invoked socket() for this local port.
	[bind()]	bind() is invoked if no prior Listen service request has invoked bind() for this local port. bind() may specify the iADT port number (4169).
	[listen()]	listen() is invoked if no prior Listen service request has invoked listen() for this local port. listen() enables the socket to accept one or more simultaneous connections.
	accept()	accept() may be invoked multiple times after a single listen(). Each invocation of Listen invokes accept() exactly one time.
Connected		accept() typically blocks until a remote socket connects to the local socket. It returns the address of the remote socket. This return causes invocation of the Connected service indication, which returns the address of the remote socket in the Connection argument.
Send	send()	
Receive	recv()	Invocation of the Receive service request causes the invocation of recv(), which will block until a message is received.
Received		recv() returns when a message is received. This return causes the invocation of the Received service indication.
Disconnect	shutdown()	
	close()	
Disconnected		After close() returns, the Disconnected service invocation is invoked.

Renumbering

Clauses presently numbered 6 and higher are renumbered to 7 and higher. Notes, figures, and tables will also need to be renumbered.