

# memorandum



Hewlett-Packard Company  
3000 Hanover Street  
Palo Alto, CA 94304-1185  
USA  
www.hp.com

T10/07-321r3

**To** INCITS T10 Committee  
**From** Michael Banther, HP  
**Subject** ADT-2 Negotiation State Machine  
**Date** 17 September 2007

## Revision history

Revision 0 – Initial proposal.

Revision 1 – Incorporated comments from the 9 July 2007 ADI-2 working group meeting.

Revision 2 – Added figure 5.

Revision 3 – Incorporated comments from the 17 September 2007 ADI-2 working group meeting.

## Related documents

Automation/Drive Interface – Transport Protocol – 2 (ADT-2), T10/1742-D, Revision 4, 11 January 2007.

## Background

During resolution of ADT letter ballot comments at the 3 May 2004 [ADI meeting](#), the working group noticed inconsistencies in the state machine descriptions (see [ADTr14](#), 4.3). Specifically statements that describe how transition from one state to another causes the port to send an information unit appear in different places depending on the transition. Sometimes a statement appears in the description of the state entered into, sometimes a statement appears in the description of the transition, and sometimes no statement appears at all.

After some discussion, the working group concluded that the standard should use a consistent approach regarding the placement of these statements. The group decided to place statements that specify the sending of an IU in the state description.

During the 1 November 2004 [ADI teleconference](#), the working group discussed the approach to use for conditional statements about sending information units that appear in the state machine text. The working group also discussed some other problems that HP's investigation into the state machine text had uncovered (see [04-350r0](#) Guidance on state machines).

This proposal changes the link negotiation state machine text to:

- a) Place the unconditional portion of each non-acknowledgement information unit statement associated with entry into a next state in the next state description clause;
- b) Place the conditional portion of each non-acknowledgement information unit statement associated with entry into a next state in the current state description clause;
- c) Retain every acknowledgement information unit statement associated with entry into a next state in the transition description clause; and
- d) Add explicit transition text for currently implicit transitions in the link negotiation state machine.

Further investigation has revealed some additional desirable changes:

- a) Several instances where the text specifies a transition from any state to N1: Negotiating state for a restart of the negotiation process have been replaced by issuing an Initiate Login message from the current state and transitioning from the current state to the N0: Idle state. This change consolidates most of the actions required to both start and restart negotiation to the N0: Idle state description, e.g. setting the Port IU parameters to starting values and the ACCEPT bit to zero. It also simplifies the description of when to use a new exchange in the N1: Negotiating state description.
- b) Adding explicit statements about all acknowledgement IU's. Previously the text mentioned acknowledgement IU's only in special cases, e.g. for timeouts in the last paragraph of 4.3.3.4.1, for implicit synchronisation in 4.3.3.6.2 and all three sub-clauses of 4.3.3.7, etc. By describing all actions involving acknowledgement IU's explicitly, this proposal eliminates any ambiguity that may result from remaining silent.
- c) Adding a specification for the case where a port in the N4: Agreed state detects an acknowledgement IU time-out.



Hewlett-Packard Company  
3000 Hanover Street  
Palo Alto, CA 94304-1185  
USA  
[www.hp.com](http://www.hp.com)

#### Proposed changes

**3.1.x negotiation error:** Any condition that results in the port sending a NAK IU with a status code of NEGOTIATION ERROR.

**3.1.x+1 requested parameters:** The set of link parameter values received in a Port Login IU.

**3.1.42 starting parameters set:** The maximum ~~values of link parameters of~~ supported parameter set under which the port is capable of operating.

**3.1.43 supported parameters set:** ~~A The set of~~ containing one value for each link parameter ~~values~~ under which the port is capable of operating.

**3.1.x+2 supported parameters:** A set consisting of all of the port's supported parameter sets.

#### 4.3.3.1 Link negotiation state machine overview

This state machine becomes active when the port enters the P1: Login state.

~~If a port receives a Port Login IU with the ACCEPT bit set to one and with parameter values that are different from the last Port Login IU sent, the port shall send a NAK IU with a status code of NEGOTIATION ERROR (see table 14) and transition to N1: Negotiating to initiate a new login exchange.~~



Figure 5 shows the link negotiation state machine. The following subclauses describe the transitions and the actions taken in each state.

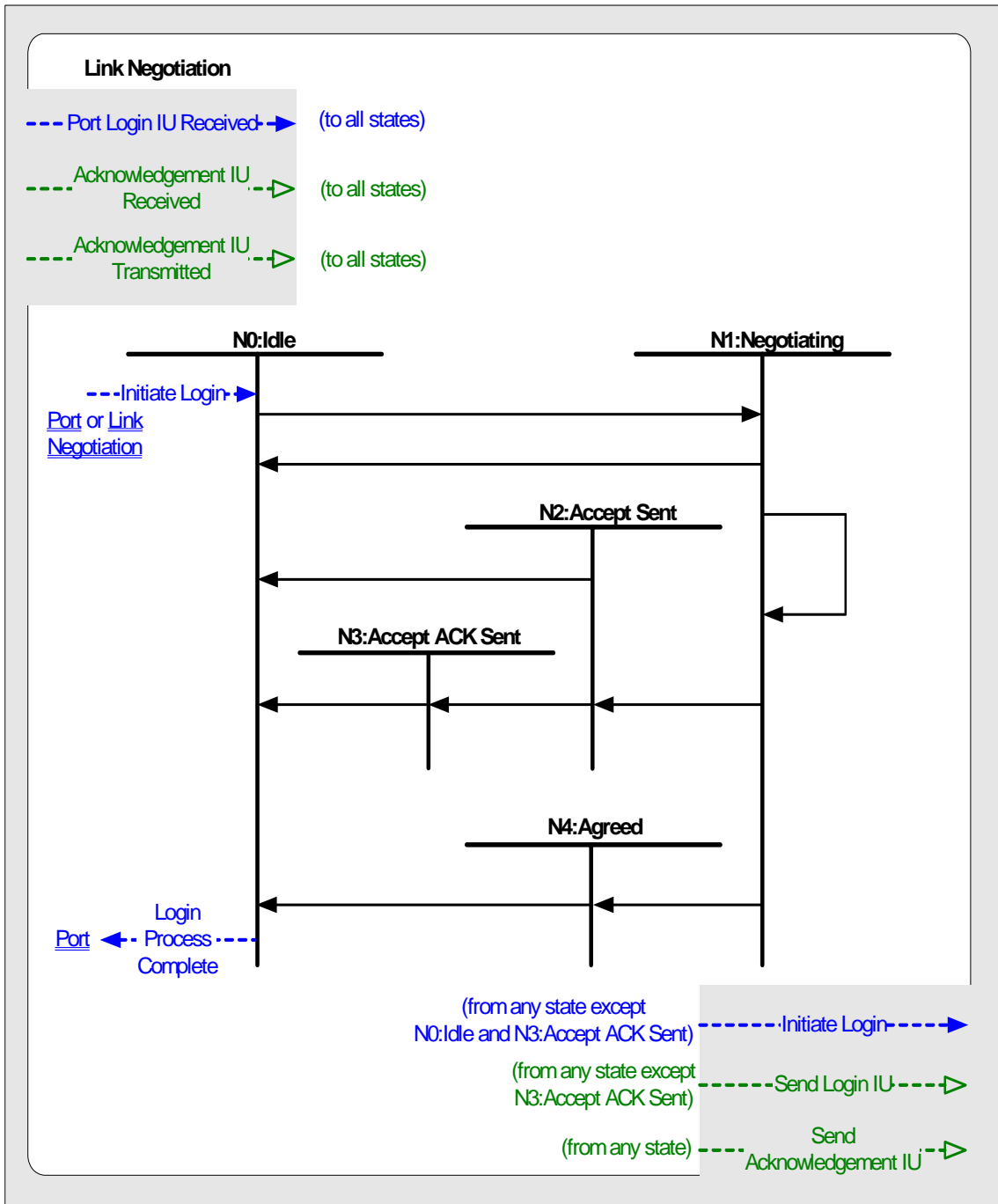

**Figure 5 – Link Negotiation State Diagram**



#### 4.3.3.3 Common renegotiation conditions

The N1: Negotiating state and the N2: Accept Sent state both behave the same under certain conditions. Both states set the port operating parameters to default and cause the link negotiation state machine to send an Initiate Login message to itself, if:

- a) The link negotiation state machine receives a Port Login IU Received message and the port detects a negotiation error (see 6.5.4);
- b) The link negotiation state machine receives an Acknowledgement IU Received message for a NAK IU;
- c) The port detects an acknowledgement IU time-out; or
- d) The following sequence occurs:
  - 1) The port sends a Port Login IU in the current exchange;
  - 2) The port receives an ACK IU for the Port Login IU;
  - 3) The port sends an Acknowledgement IU Received message to the link negotiation state machine;
  - 4) The link negotiation state machine receives the Acknowledgement IU Received message send by the port;
  - 5) The port transitions to a new state due to receiving the Acknowledgment IU Received message; and
  - 6) The link negotiation state machine fails to receive a Port Login IU Received message within 15 seconds after entering the state.

#### 4.3.3.34 N0: Idle state

##### 4.3.3.34.1 State description

The N0: Idle state waits for the ~~port~~ link negotiation state machine to receive a Port Login IU Received message or an Initiate Login message.

While in the N0: Idle state, if the link negotiation state machine receives a Port Login IU Received message and the requested parameters (see 3.1.x) in the corresponding Port Login IU are not an element of the supported parameters (see 3.1.y), then for the next Port Login IU the port sends it shall:

- a) Set the ACCEPT bit to zero; and
- b) Adjust link parameters, the MAJOR REVISION field, and the MINOR REVISION field as specified in 6.5.4.

While in the N0: Idle state, if the link negotiation state machine receives a Port Login IU Received message and the requested parameters in the corresponding Port Login IU are an element of the supported parameters, then for the next Port Login IU the port sends it shall set:

- a) The ACCEPT bit to one; and
- b) All other parameters to the corresponding values from the received Port Login IU.

While in the N0: Idle state, if the link negotiation state machine receives a Port Login IU Received message and the port detects a negotiation error, the port shall both set the ACCEPT bit to zero and set the other link parameters to starting parameters (see 3.1.41) for the next Port Login IU it sends. See 6.5.4 for additional information about setting values for the MAJOR REVISION field and the MINOR REVISION field.

While in the N0: Idle state, if the link negotiation state machine receives an Initiate Login message, the port shall both set the ACCEPT bit to zero and set the other link parameters to starting parameters (see 3.1.41) for the next Port Login IU it sends. See 6.5.4 for additional information about setting values for the MAJOR REVISION field and the MINOR REVISION field.

A link negotiation state machine in the N0: Idle state shall remain in the N0: Idle state when the port sends a NAK IU for a Port Login IU Received message (see 4.6.2.5.1 and 4.6.2.6.1).



#### 4.3.3.34.2 Transition N0: Idle to N1: Negotiating

~~A port~~ The link negotiation state machine shall transition from N0: Idle to N1: Negotiating ~~when~~:

- a) When the port sends an ACK IU for a Port Login IU Received message ~~is received and the link parameters (see 3.1.23) values within the Port Login IU are not in the supported parameters (see 3.1.42) of the port;~~ or
- b) When the link negotiation state machine receives an Initiate Login message ~~is received~~.

#### 4.3.3.3.3 Transition N0: Idle to N2: Accept Sent

~~If the received Port Login IU has the ACCEPT bit set to zero and the link parameter (see 3.1.23) values are in the supported parameters (see 3.1.44) of the port, the port shall transition to N2:Accept Sent and send a Port Login IU with the link parameter values unchanged and the ACCEPT bit set to one.~~

#### 4.3.3.45 N1: Negotiating state

##### 4.3.3.45.1 State description

When the link negotiation state machine enters the N1: Negotiating state the port shall send a Port Login IU. ~~If the port transitioned to this state as the result of an Initiate Login message,~~ The port shall send a the Port Login IU in a new exchange ~~with the ACCEPT bit set to zero and the link parameter values set to the starting parameters~~ if the link negotiation state machine transitioned to the N1: Negotiating state as the result of an Initiate Login message (see 4.3.3.3.1 for the value of the link parameters and the ACCEPT bit).

~~If the port transitioned to this state as a result of a negotiation error, the port shall send a Port Login IU in a new exchange. The Port Login IU shall contain starting parameters. The ACCEPT bit shall be set to zero.~~

The port shall send the Port Login IU in the existing exchange if the link negotiation state machine transitioned to the N1: Negotiating state as a result of a Port Login IU Received message and the port does not detect a negotiation error (see 4.3.3.3.1 and this subclause for the value of the link parameters and the ACCEPT bit).

~~When a Port Login IU message is received, the parameters shall be inspected. If the value of any of the link parameters (see 3.1.23) specified in Port Login IU are not supported parameters (see 3.1.44), the port shall adjust all link parameter values that are not supported by the port and respond with a Port Login IU that contains these adjusted link parameter values. The ACCEPT bit shall be set to zero. The method of adjusting link parameter values in a Port Login IU is described in 6.5.4.~~

~~If a port has not received a Port Login IU within 15 seconds after receiving the ACK IU for a Port Login IU that it has sent, the port shall consider this condition an error. The port shall abort the Port Login exchange, set the port operating parameters to default, and initiate a new Port Login exchange.~~

A port with a link negotiation state machine in the N1: Negotiating state shall set the port operating parameters to default and the link negotiation state machine shall send an Initiate Login message to itself if detection of one of the common renegotiation conditions occurs (see 4.3.3.3).

If a link negotiation state machine in the N1: Negotiating state receives a Port Login IU Received message and the corresponding Port Login IU contains requested parameters that are not an element of the supported parameters, then for the next Port Login IU the port sends it shall:

- a) Set the ACCEPT bit to zero; and
- b) Adjust link parameters, the MAJOR REVISION field, and the MINOR REVISION field as specified in 6.5.4.

If a link negotiation state machine in the N1: Negotiating state receives a Port Login IU Received message and the requested parameters in the corresponding Port Login IU are an element of the supported parameters, then for the next Port Login IU the port sends it shall set:

- a) The ACCEPT bit to one; and
- b) All other parameters to the corresponding values from the received Port Login IU.



#### 4.3.3.45.2 Transition N1: Negotiating to N0: Idle

~~If a port sends a NAK IU in response to a Port Login IU it shall transition to N0: Idle.~~

A link negotiation state machine in the N1: Negotiating state shall transition to the N0: Idle state when it sends an Initiate Login message.

#### 4.3.3.5.3 Transition N1: Negotiating to N1: Negotiating

A link negotiation state machine in the N1: Negotiating state shall transition to the N1: Negotiating state when the port sends an ACK IU in response to the link negotiation state machine receiving a Port Login IU Received message.

NOTE W: Transition from the N1: Negotiating state to the N1: Negotiating state implies entry into the N1: Negotiating state.

#### 4.3.3.45.34 Transition N1: Negotiating to N2: Accept Sent

~~If the ACCEPT bit is set to zero and the link parameters (see 3.1.22) in the received Port Login IU are supported parameters (see 3.1.42), the port shall send a Port Login IU with the link parameters unchanged and the ACCEPT bit set to one and transition to N2: Accept Sent.~~

A link negotiation state machine in the N1: Negotiating state shall transition to the N2: Accept Sent state when the port sends a Port Login IU with the ACCEPT bit set to one and the most recently received Port Login IU had the ACCEPT bit set to zero.

#### 4.3.3.45.45 Transition N1: Negotiating to N4: Agreed

~~If the ACCEPT bit is set to one and the link parameters in the received Port Login IU are unchanged from the values sent in the last Port Login IU, the port shall send a Port Login IU with the same values and the ACCEPT bit set to one and transition to N4: Agreed.~~

A link negotiation state machine in the N1: Negotiating state shall transition to the N4: Agreed state when the port sends a Port Login IU with the ACCEPT bit set to one and the most recently received Port Login IU had the ACCEPT bit set to one.

#### 4.3.3.56 N2: Accept Sent state

##### 4.3.3.56.1 State description

~~A port enters~~ link negotiation state machine reaches the N2: Accept Sent ~~this~~ state if ~~#~~ the port has sent a Port Login IU with the ACCEPT bit set to one and with parameters unchanged before it received a Port Login IU with the ACCEPT bit set to one (i.e., it is the first port to send a Port Login IU with the ACCEPT bit set to one). ~~When the link negotiation state machine enters the N2: Accept Sent state it shall take no action until:~~

- a) It receives an Acknowledgement IU Received message; or
- b) The port detects an acknowledgement IU time-out.

If a link negotiation state machine in the N2: Accept Sent state receives an Acknowledgement IU Received message for an ACK IU, it shall take no action until it:

- a) Receives a Port Login IU Received message; or
- b) Has not received a Port Login IU Received message within 15 seconds after receiving the Acknowledgement IU Received message.



A port with a link negotiation state machine in the N2: Accept Sent state shall set the port operating parameters to default and the link negotiation state machine shall send an Initiate Login message to itself if detection of one of the common renegotiation conditions occurs (see 4.3.3.3).

A port with a link negotiation state machine in the N2: Accept Sent state shall send an ACK IU if the link negotiation state machine receives a Port Login IU Received message and:

- a) Each requested parameter in the received Port Login IU has the same value as the corresponding requested parameter in the most recently sent Port Login IU; and
- b) The ACCEPT bit in the received Port Login IU is set to one.

A port with a link negotiation state machine in the N2: Accept Sent state shall send a NAK IU if the link negotiation state machine receives a Port Login IU Received message and:

- a) A requested parameter in the received Port Login IU has a different value than the corresponding requested parameter in the most recently sent Port Login IU; or
- b) The ACCEPT bit in the received Port Login IU is set to zero.

#### **4.3.3.56.2 Transition N2: Accept Sent to N0: Idle**

~~If a port receives a Port Login IU with a protocol error or resource limitation error, the port shall send a NAK IU and transition to N0: Idle.~~

A link negotiation state machine in the N1: Negotiating state shall transition to the N0: Idle state when it sends an Initiate Login message.

#### **~~4.3.3.56.3 Transition N2: Accept Sent to N1: Negotiating~~**

~~If a port receives a Port Login IU with the ACCEPT bit set to zero or with parameter values that are different from the last Port Login IU sent, the port shall send a NAK IU with a status code of NEGOTIATION\_ERROR (see table 14) and transition to N1: Negotiating to initiate a new login exchange.~~

#### **4.3.3.56.43 Transition N2: Accept Sent to N3: Accept ACK Sent**

~~If a port receives a Port Login IU with the ACCEPT bit set to one and with parameters unchanged, the port shall send an ACK IU and transition to N3: Accept ACK Sent.~~

A link negotiation state machine in the N2: Accept Sent state shall transition to the N3: Accept ACK Sent state when the port sends an ACK IU in response to receiving a Port Login IU Received message.

#### **4.3.3.67 N3: Accept ACK Sent state**

##### **4.3.3.67.1 State description**

A port enters link negotiation state machine reaches the N3: Accept ACK Sent ~~this~~ state if ~~it~~ the port has sent a Port Login IU with the ACCEPT bit set to one and with parameters unchanged, and then received a Port Login IU with the ACCEPT bit set to one. When the link negotiation state machine enters the N3 Accept ACK Sent state:

1. The port shall wait until completion of the transmission of the ACK IU sent at the transition from the N2: Accept Sent state to the N3: Accept ACK Sent state; and
2. The link negotiation state machine shall send a Login Process Complete message to the port state machine.

##### **4.3.3.67.2 Transition N3: Accept ACK Sent to N0: Idle**

~~When the ACK IU has finished transmitting, the port shall send a Login Process Complete message to the port state machine and transition to N0: Idle.~~

A port in the N3: Accept ACK Sent state shall transition to the N0: Idle state when it sends a Login Process Complete message to the port state machine.



#### 4.3.3.78 N4: Agreed state

##### 4.3.3.78.1 State description

A port enters link negotiation state machine reaches the N4: Agreed ~~this~~ state if the port has sent a Port Login IU with the ACCEPT bit set to one and with parameters unchanged after it received a Port Login IU with the ACCEPT bit set to one and with parameters unchanged (i.e., it is the second port to ~~accept the operating parameters~~ send a Port Login IU with the ACCEPT bit set to one). ~~A port in this state is waiting for the ACK IU sent in response to the Port Login IU it sent (see clause 4.3.3.4.4).~~

When the link negotiation state machine enters the N4: Agreed state, it shall wait until:

- It receives an Acknowledgement IU Received message; or
- The port detects an acknowledgement IU time-out.

If the link negotiation state machine receives an Acknowledgement IU Received message for an ACK IU, it shall send a Login Process Complete message to the port state machine.

If the link negotiation state machine receives an Acknowledgement IU Received message for a NAK IU or the port detects an acknowledgement IU time-out, the port shall set the port operating parameters to default and the link negotiation state machine shall send an Initiate Login message to itself.

##### ~~4.3.3.7.2 Transition N4: Agreed to N1: Negotiating~~

~~If a port receives a NAK IU it shall transition to N1: Negotiating to initiate a new login exchange.~~

##### 4.3.3.78.32 Transition N4: Agreed to N0: Idle

~~After receiving an ACK IU for the Port Login IU it sent, the port shall send a Login Process Complete message to the port state machine and transition to N0: Idle.~~

A port in the N4: Agreed state shall transition to the N0: Idle state when it receives an Acknowledgement IU Received message or the port detects an acknowledgement IU time-out (see 4.6.2.4.1).

#### 4.6.2.4.1 Port login IUs

A port ~~that is with a port state machine~~ in P1: Login state that receives a NAK IU or detects an acknowledgment IU time-out shall restart the negotiation by sending an Initiate Login message, transitioning the link negotiation state machine to ~~N1: Negotiating~~ N0: Idle state, setting operating parameters to default (see 4.2), and initiating a new login exchange using starting parameters.

#### 6.5.4 Port login information unit

The ACCEPT bit shall be set to zero on the first Port Login IU of a negotiation exchange and all subsequent Port Login IUs sent by a port until the Port Login IU parameters it is sending matches the parameters of the last Port Login IU received. If the Port Login IU parameters sent by a port matches the parameters of the last Port Login IU it received, the ACCEPT bit shall be set to one.

A port that receives a Port Login IU with the ACCEPT bit set to one shall respond with a NAK IU with a status code of NEGOTIATION ERROR (see table 14) if:

- The link negotiation state machine is in N0: Idle state (see 4.3.3.3); or
- The parameter values, other than the ACCEPT bit, of the Port Login IU received differ from the parameter values of the most recent Port Login IU sent by the port.

A port that receives a Port Login IU with the ACCEPT bit set to zero shall respond with a NAK IU with a status code of NEGOTIATION ERROR (see table 14) if the link negotiation state machine is in N2: Accept Sent state (see 4.3.3.3).

The MAXIMUM PAYLOAD SIZE field indicates the maximum number of bytes in the payload of a frame that the port is able to accommodate. The MAXIMUM PAYLOAD SIZE field shall be set to at least 256 bytes to accommodate a SCSI Response IU with the maximum sense length of 252 bytes (see 7.1.4). If a port receives a Port Login IU containing a maximum payload size value less than 256 it shall respond with a NAK IU with a status code of NEGOTIATION ERROR (see table 14) ~~and transition to~~ ~~N1: Negotiating to initiate a new login exchange.~~

The BAUD RATE field indicates the speed that the port's physical interface shall run after completion of negotiation. The BAUD RATE field contains the desired nominal Baud rate divided by 100. All ports shall default to operating at 9 600 Baud at power-up and following error conditions that require re-establishment of the operating parameters (see 4.6.2). If a port receives a Port Login IU





Hewlett-Packard Company  
3000 Hanover Street  
Palo Alto, CA 94304-1185  
USA  
www.hp.com

containing a baud rate value less than 9 600 it shall respond with a NAK IU with a status code of NEGOTIATION ERROR (see table 14) ~~and transition to N1: Negotiating to initiate a new login exchange.~~

If a port receives a Port Login IU containing requested parameters (see 3.1.x) that are not an element of the supported parameters (see 3.1.y), then the port shall set the value of the link parameters for the next Port Login IU it sends in the current exchange such that:

- a) the value for each link parameter in the supported parameter set is less than or equal to the value of that parameter in the requested parameters; and
- b) the value of at least one link parameter in the supported parameter set is strictly less than the value of the parameter in the requested parameters.

### **C.1 Introduction**

The DT device port has the following capabilities:

- a) support for the INCITS approved revision of this standard ~~as well as draft revision 9;~~