

To: T10 Technical Committee
From: Tim Symons, PMC-Sierra (Tim_Symons@pmc-sierra.com)
Date: 9 January 2007
Subject: 07-028r0 SAS-2 Address resolved zoning

Revision Information

- Revision 0: First draft.

Referenced Document

sas2r07 Serial Attached SCSI – 2 (SAS-2) revision 7

Overview

SAS2r07 defines the ADDRESS RESOLVED ZONING bit in a number of functions but there is no definition on how to configure zoning for address resolved ports, or behavior on link loss and recovery conditions.

There are no current proposals to define how to implement address resolved zoning.

This is a proposal to remove the address resolved references from the SAS2 draft.

[Suggested addition to SAS-2 existing text (included in black), new additional text (included in blue) and changes between revisions shown in red]

4.9.1 Zoning overview

...

An expander phy inside a ZPSDS shall be assigned to zone group 1. A phy that is attached to the boundary of the ZPSDS (i.e., attached to an expander phy with the INSIDE ZPSDS bit set to zero) belongs to the zone group indicated by the ZONE GROUP field of the expander phy to which it is attached. ~~A phy that is not attached to the boundary of the ZPSDS belongs to a zone group if the ZONE ADDRESS RESOLVED bit is set to one in the boundary expander phy and the zoning expander route table in that expander device contains a zone group value for the phy's SAS address.~~

...

4.9.3.1 Zone phy information

Each phy of a zoning expander device shall support the following zone phy information fields:

- INSIDE ZPSDS bit;
- REQUESTED INSIDE ZPSDS bit;
- INSIDE ZPSDS PERSISTENT bit;
- ~~ZONE ADDRESS RESOLVED bit;~~
- ZONE GROUP PERSISTENT bit; and
- ZONE GROUP field.

...

~~The ZONE ADDRESS RESOLVED bit specifies the method used to determine the source zone group for a connection request received by a phy at the boundary of the ZPSDS as specified in table 27 (see 4.9.3.5).~~

~~The ZONE ADDRESS RESOLVED bit may be set to one if the INSIDE ZPSDS bit for the phy is set to zero.~~

~~The ZONE ADDRESS RESOLVED bit shall be set to zero if the INSIDE ZPSDS bit for the phy is set to one.~~

...

4.9.3.3 Zone permission table

...

If an expander phy has the ZONE ADDRESS RESOLVED bit set to one, then the zone group of that phy shall be configured to have permission to access all the zone groups to which the SAS addresses in the zoning expander route table for that expander phy have access (e.g., in figure 57 in 4.9.3.5, zone group 18 has access to all the zone groups that the end devices in its routing table have access).

...

4.9.3.5 Source zone group and destination zone group determination

...

Zoning expander devices with zoning enabled shall follow the rules in table 27 to determine the zone group of the source port.

Table 27 — Source zone group determination

| Attribute of the expander phy that received the OPEN address frame | | Source zone group |
|--|------------------|--|
| Routing method | INSIDE ZPSDS bit | |
| Any | 0 | Zone group of the receiving expander phy |
| | 1 | Source zone group specified by the SOURCE ZONE GROUP field in the received OPEN address frame. |

Table 27 — Source zone group determination

| Attribute of the expander phy that received the OPEN address frame | | | Source zone group | |
|--|----------------|------------------|--|---|
| ZONE ADDRESS RESOLVED bit | Routing method | INSIDE ZPSDS bit | | |
| 0 | Any | 0 | Zone group of the receiving expander phy | |
| | | 1 | Source zone group specified by the SOURCE ZONE GROUP field in the received OPEN address frame. | |
| 1 | Direct | 0 | Zone group of the receiving expander phy. | |
| | | 1 | Not applicable | |
| | Subtractive | 0 | Zone group of the receiving expander phy. | |
| | | 1 | Not applicable | |
| | Table | | 0 | Zone group stored in the zoning expander route table for the source SAS address. If the source SAS address is not found in the zoning expander route table then the zone group of the receiving expander phy. |
| | | | 1 | Not applicable. |

...

...

Figure 56 shows an example of a ZPSDS in which the ZONE ADDRESS RESOLVED bit of the expander port of expander device C that is attached to expander device D is set to zero.

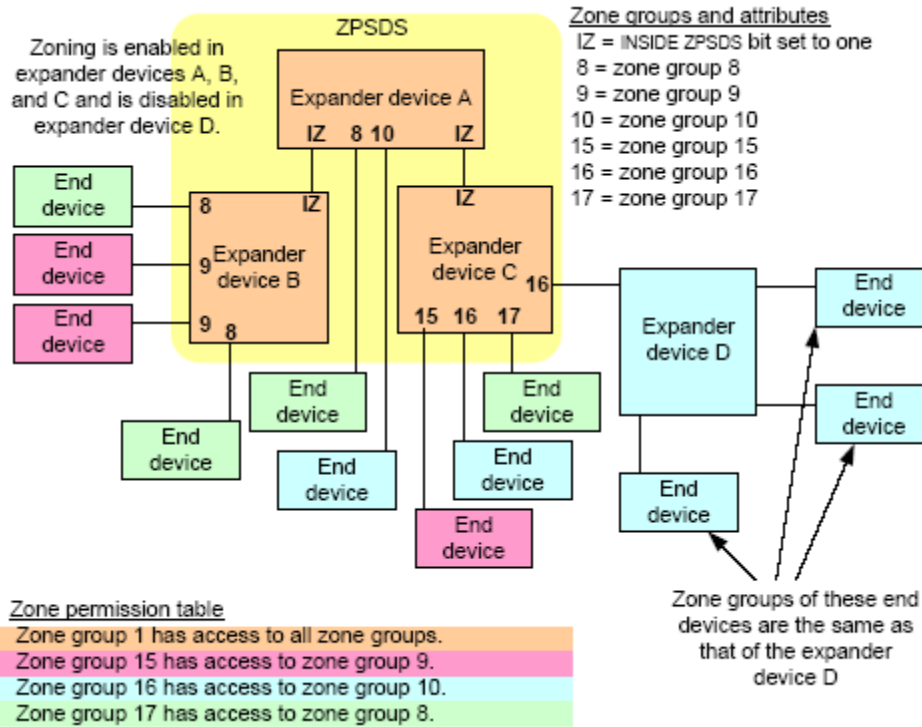

Figure 56 — Example of a ZPSDS with the ZONE ADDRESS RESOLVED bit set to zero

~~Figure 57 shows an example of a ZPSDS in which the ZONE ADDRESS RESOLVED bit of the expander port of expander device C that is attached to expander device D is set to one.~~

 Editors Note: DELETE FIGURE 57

4.9.4 Zone phy information and link reset sequences

...

| REQUESTED INSIDE ZPSDS bit | | INSIDE ZPSDS PERSISTENT bit | | Zone phy information field changes |
|-------------------------------|----------|--------------------------------|----------|--|
| Transmitted | Received | Transmitted | Received | |
| 0 | 0 or 1 | 0 or 1 | 0 or 1 | The zoning expander device shall set the INSIDE ZPSDS bit to zero. |
| 1 | 0 | | | |
| 1 | 1 | 0 | 0 | If the SAS address received in the IDENTIFY address frame during the identification sequence is different from the SAS address prior to the completion of the link reset sequence, then the zoning expander device shall set: a) the REQUESTED INSIDE ZPSDS bit to zero; and b) the INSIDE ZPSDS bit to zero. |
| | | 0 | 0 | |
| | | 1 | 0 | If the SAS address received in the IDENTIFY address frame during the identification sequence is the same as the SAS address prior to the completion of the link reset sequence, then the zoning expander device shall set: a) the INSIDE ZPSDS bit to one; and b) the ZONE GROUP field to one; and c) the ZONE ADDRESS RESOLVED bit to zero. |
| | | 1 | 1 | The zoning expander device shall set: a) the INSIDE ZPSDS bit to one; and b) the ZONE GROUP field to one; and c) the ZONE ADDRESS RESOLVED bit to zero. |

...

10.4.3.3 REPORT GENERAL function

...

Table 217 – REPORT GENERAL response

| Byte\Bit | 7 | 6 | 5 | 4 | 3 | 2 | 1 | 0 |
|----------|--------------------------|----------|---|--|-------------------|-------------|-------------------------------------|---|
| ... | ... | | | | | | | |
| 10 | TABLE TO TABLE SUPPORTED | Reserved | | ZONE ADDRESS RESOLVED SUPPORTED Reserved | CONFIGURES OTHERS | CONFIGURING | EXTERNALLY CONFIGURABLE ROUTE TABLE | |
| ... | ... | | | | | | | |

...

A ~~ZONE ADDRESS RESOLVED SUPPORTED~~ bit set to one indicates that the zoning expander device supports address resolved zoning. A ~~ZONE ADDRESS RESOLVED SUPPORTED~~ bit set to zero indicates that the zoning expander device does not support address resolved zoning (see 4.9.3.1).

...

10.4.3.7 DISCOVER function

...

Table 229 – DISCOVER response

| Byte\Bit | 7 | 6 | 5 | 4 | 3 | 2 | 1 | 0 |
|----------|----------|---|-------------------------------|------------------------------|---|--------------------------|-----------------|-------------------|
| ... | ... | | | | | | | |
| 60 | Reserved | REQUESTED INSIDE ZPSDS CHANGED BY EXPANDER | INSIDE ZPSDS PERSISTENT | REQUESTED INSIDE ZPSDS | ZONE ADDRESS RESOLVED Reserved | ZONE GROUP PERSISTENT | INSIDE ZPSDS | ZONING ENABLED |
| ... | ... | | | | | | | |

...

The ZONE ADDRESS RESOLVED bit contains the value of the ZONE ADDRESS RESOLVED bit in the zone phy information (see 4.9.3.1).

...

10.4.3.13.4 DISCOVER LIST response SHORT FORMAT descriptor

...

Table 253 – SHORT FORMAT descriptor

| Byte\Bit | 7 | 6 | 5 | 4 | 3 | 2 | 1 | 0 |
|----------|---|-------------------------------|------------------------------|---|--------------------------|-----------------|----------|----------|
| ... | ... | | | | | | | |
| 9 | Restricted for DISCOVER response byte 60 | INSIDE ZPSDS PERSISTENT | REQUESTED INSIDE ZPSDS | ZONE ADDRESS RESOLVED Reserved | ZONE GROUP PERSISTENT | INSIDE ZPSDS | Reserved | Reserved |
| ... | ... | | | | | | | |

...

10.4.3.21.3 Zone phy configuration descriptor

...

Table 273 – Zone phy configuration descriptor

| Byte\Bit | 7 | 6 | 5 | 4 | 3 | 2 | 1 | 0 |
|----------|----------------|-------------------------------|------------------------------|---|--------------------------|----------|----------|----------|
| 0 | PHY IDENTIFIER | | | | | | | |
| 1 | Reserved | INSIDE ZPSDS PERSISTENT | REQUESTED INSIDE ZPSDS | ZONE ADDRESS RESOLVED Reserved | ZONE GROUP PERSISTENT | Reserved | Reserved | Reserved |
| 2 | Reserved | | | | | | | |
| 3 | ZONE GROUP | | | | | | | |

...

The ZONE ADDRESS RESOLVED bit specifies the value of the ZONE ADDRESS RESOLVED bit in the zone phy information (see 4.9.3.1). If a zoning expander device does not support address resolved zoning (i.e., the ZONE ADDRESS RESOLVED SUPPORTED bit is set to zero in the REPORT GENERAL response) and the ZONE ADDRESS RESOLVED bit is set to one, then the management device server

~~shall return a function result of UNKNOWN_ZONE_PHY_INFORMATION_VALUE in the response frame~~

...