

SAS-2 10-Meter Cable Specification Issues (06-499r5)



Barry Olawsky
Hewlett Packard
(SAS FTF - 7/10/2007)

Existing External Cable Specification (for 1.5 and 3Gbps)



Requirement ^{a, b}	Units	1,5 Gbps	3 Gbps
Bulk cable: ^{c, d}			
Differential impedance	ohm	100 ± 5	
Maximum differential impedance imbalance ^e	ohm	5	
Common-mode impedance	ohm	32,5 ± 7,5	
Mated connectors:			
Differential impedance ^{f, d}	ohm	100 ± 10	
Cable assembly: ^g			
Maximum insertion loss		See 5.3.3	
Maximum rise time ^{h, i}	ps	150	
Maximum ISI ^j	ps	60	
Maximum intra-pair skew ^{h, k}	ps	50	

Note: 10m cable budgets were not defined for SAS1.1 (1.5 & 3Gbps)

Issues for Discussion



- The original intent of TCTF was a test load definition and not an insertion loss mask. Insertion loss mask specifications are problematic because they either disqualify designs with adequate margin or if specified too leniently, pass designs which are prone to interoperability issues due to insufficient margin.
- Intra-skew spec is difficult to meet on longer cables. The significance of intra-pair skew needs to be proven. Don't expect a common mode conversion specification to be any easier to meet.

Issues for Discussion (continued)



- Applying the rise time test to long cables results in an output waveform that is very exponential. Precise measurements become very difficult.
- Furthermore, what significance does signal amplitude have a 2 or 3UI compared to 1UI?

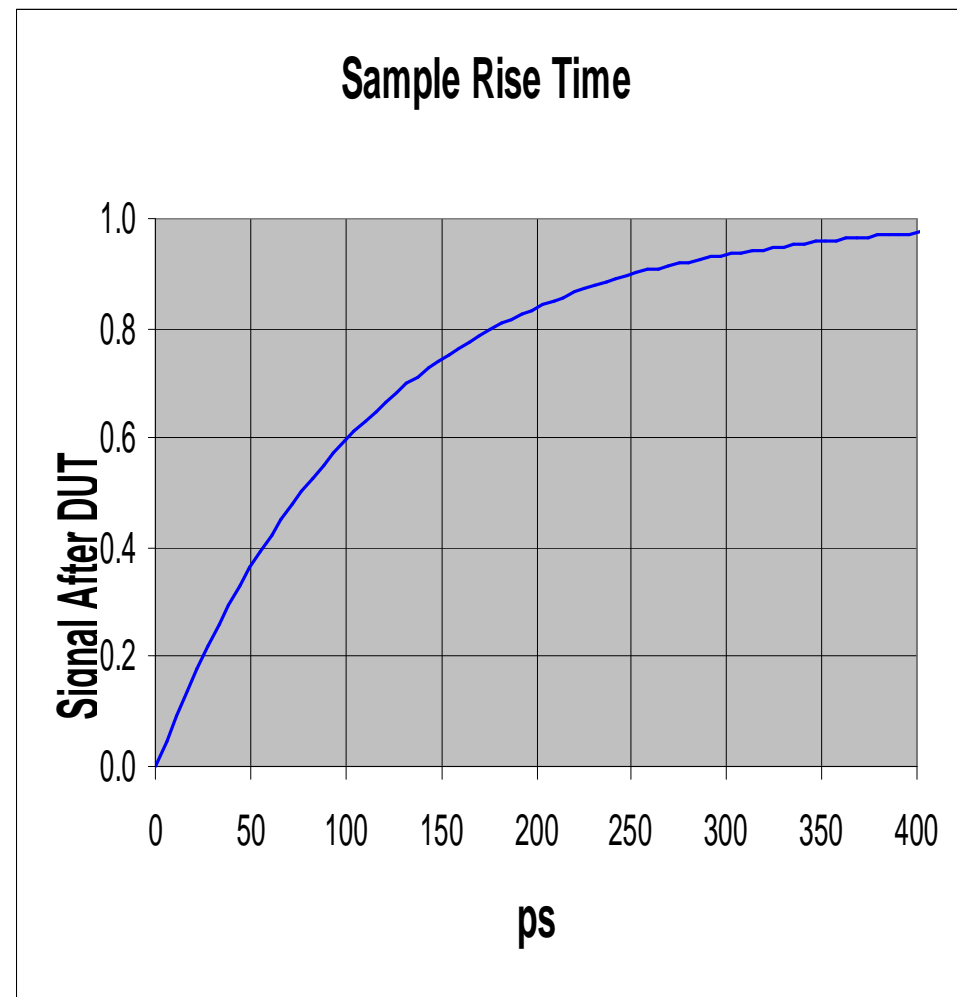

Wrap-up



- Modeling and simulation may prove that we are focusing on parameters that are of minimal importance.
- Do we need to consider a channel based specification for cables too?

Revision 1 Updates



- The most contentious parameter in any of the cable specification is skew. The plan was to work with bulk cable suppliers to statistically characterize the differential to common mode conversion. This would then be an indicator of potential emissions.
- Further work on this topic was done in SFF8416, Annex C.
- I am now convinced my earlier goal is unattainable

Skew and Coupling



- Skew is to some degree self-limiting when applied to differentially coupled interconnect
- A sequence of small steps in skew demonstrate this effect
- The situation in bulk cable is not exactly the same. The coupling is tight and spans the sections where skew is generated

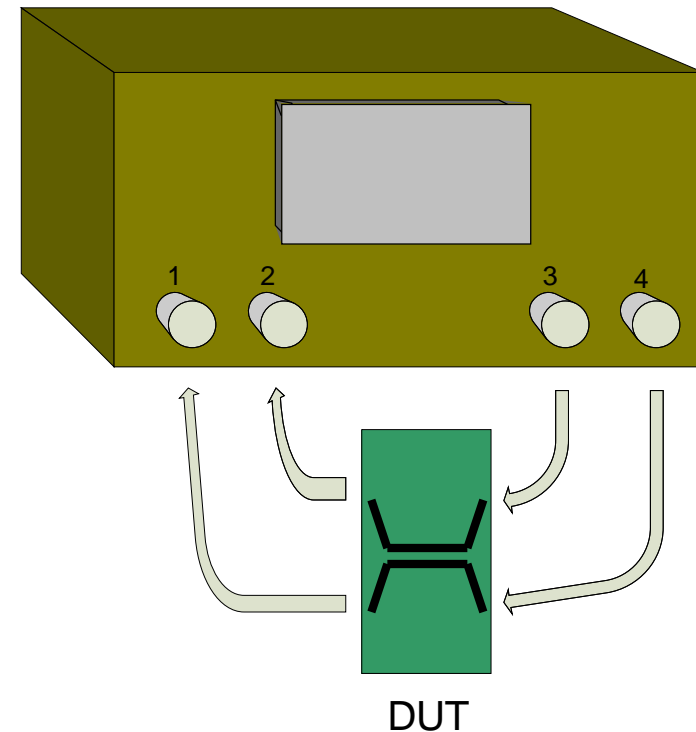

Skew and Coupling

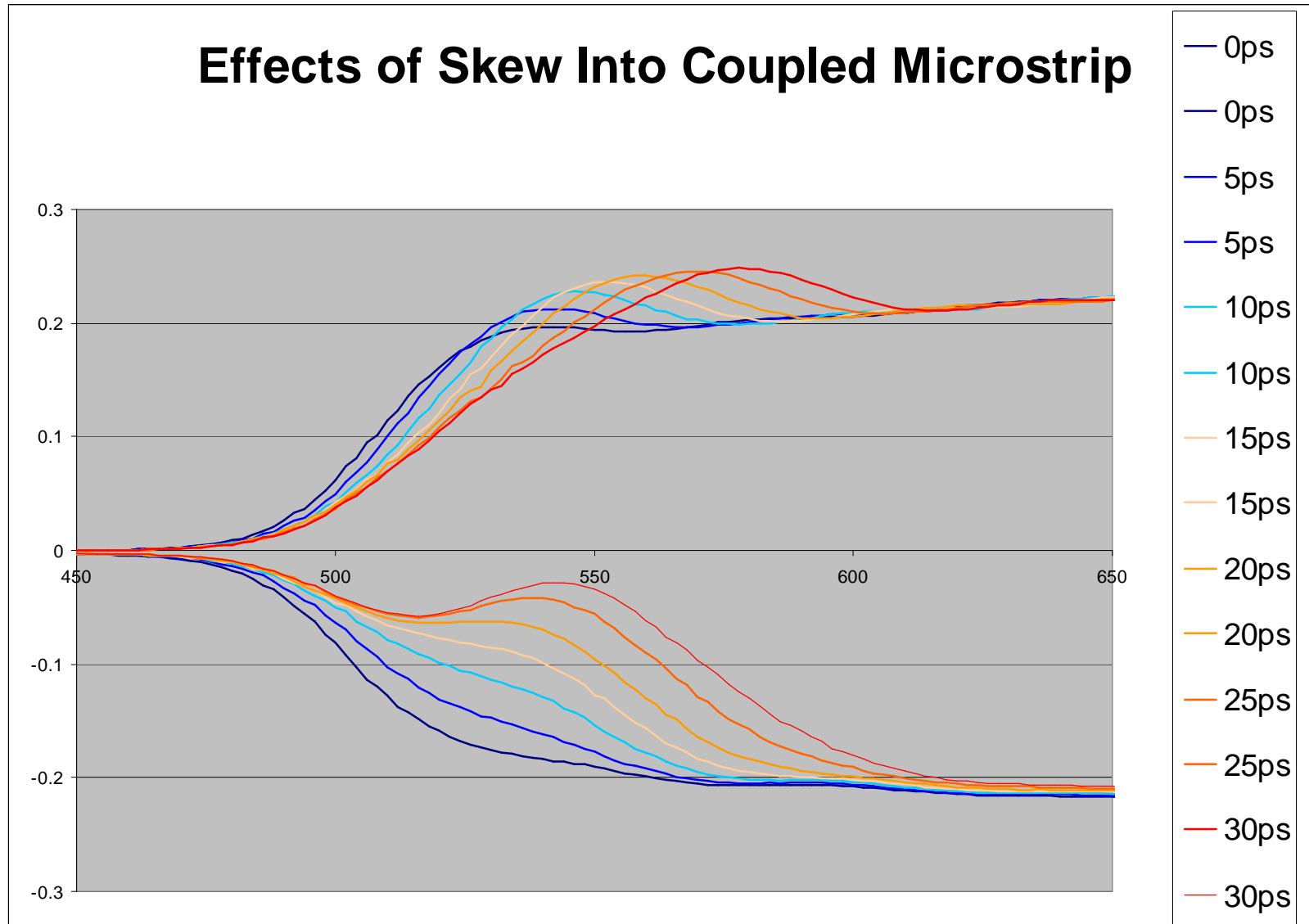

Observations



- The signals within a tightly coupled pair interact in an intentional way.
- As skew is increased, the lead leg experiences what appears to be an overshoot while the trailing leg is slowed
- To understand why this is we need to capture the FEXT of a tightly coupled pair

Observations

- The FEXT is inductive coupling which induces a spike in the victim with a polarity opposite of the aggressor. For differential signaling, the FEXT pulse would then be the same polarity as the victim edge – reinforcing the edge.

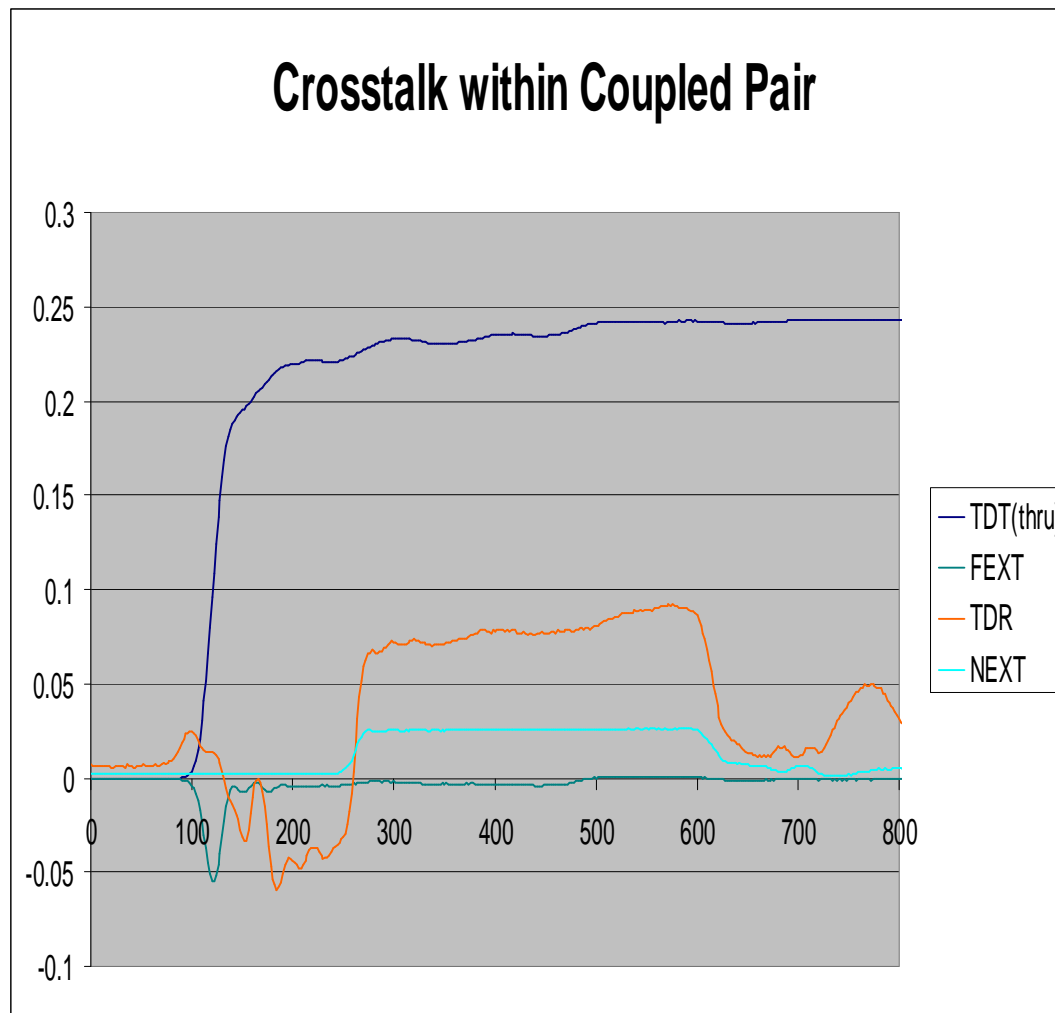

Observations



- For differential signaling, the FEXT pulse would then be the same polarity as the victim edge. With the result of reinforcing the edge.
- In the absence of signal on one leg, the trailing edge would start early and not reach full potential. The leading leg will get a spike after it's transition is complete.
- In conclusion, both waveforms are distorted. The "skew" parameter does not accurately describe this undesirable effect. Further work is required to understand how much differential to common mode conversion can be expected and tolerated.

Mismatch & Skew Measurements



- Mismatch in twin-axial cable constructions has been documented in multiple forums (i.e., SFF) and exists regardless of what metric is used to quantify it.
- Examining multiple samples will be the first step in creating a realistic set of performance characteristics
- SFF8410 describes the single pulse method of measuring propagation time skew which will be utilized here. The skew is defined as the time position difference of the midpoints of the received pulses

Mismatch & Skew Measurements



- First the bulk cable (10m) mismatch will be examined using ideal termination methods, then more realistic termination methods will be considered and lastly actual cable assembly designs will be considered.
- H-Spice simulations using measured S-parameter are used to analyze the mismatch
- Results are compared to TDT measurements (thru measurement with a TDR pulse generator as the source)

Delivered Differential Step (Bulk Cable Only)

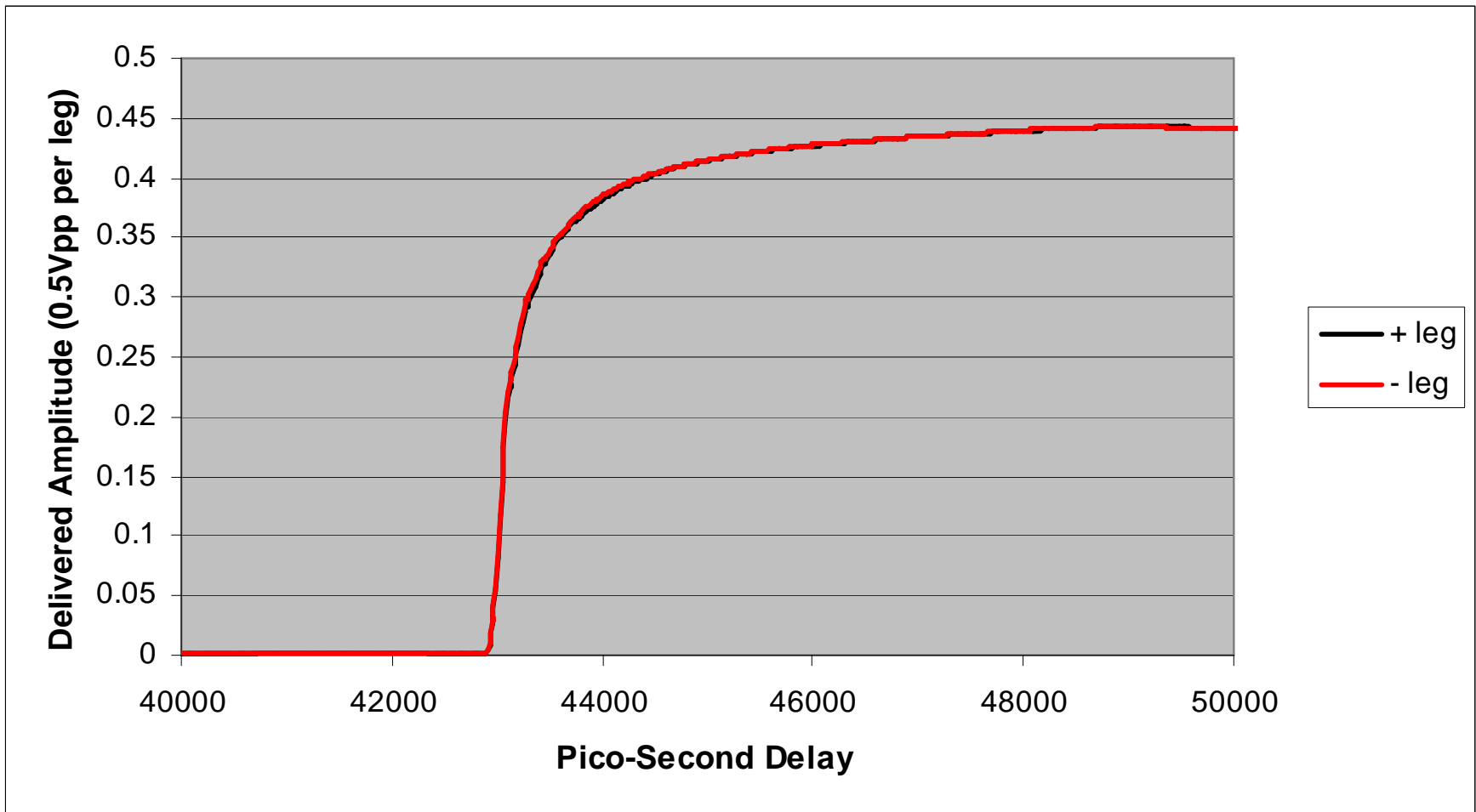

Skew At Midpoint (Bulk Cable Only)

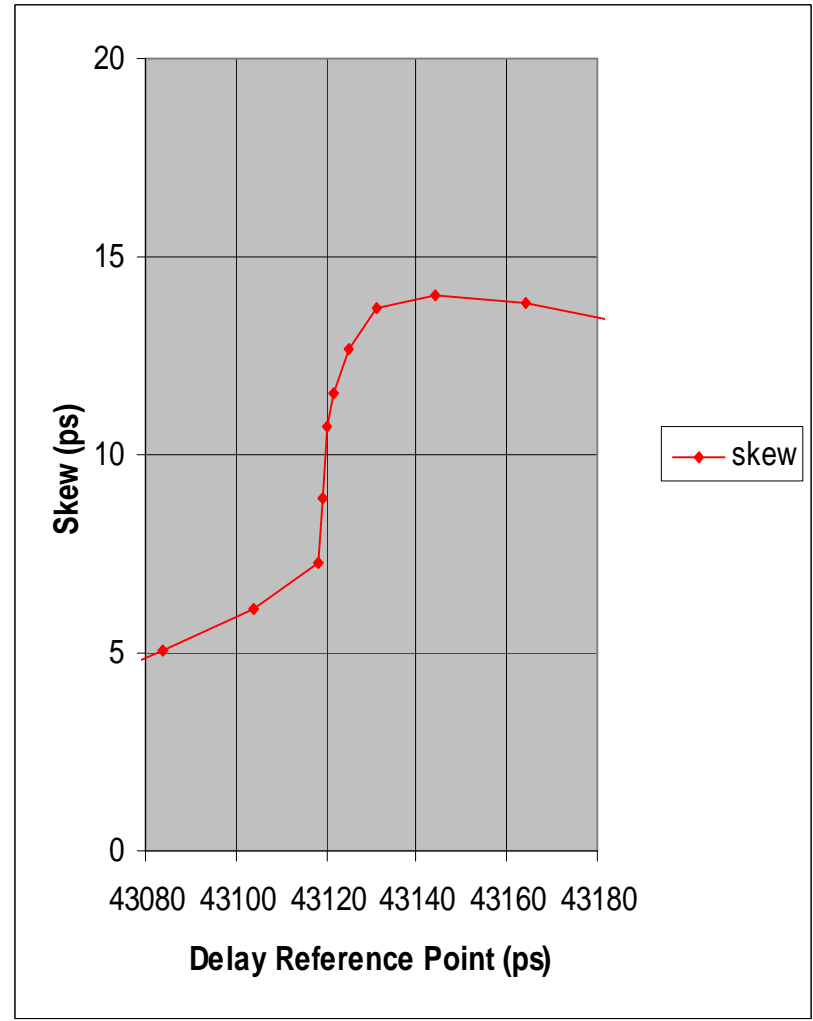
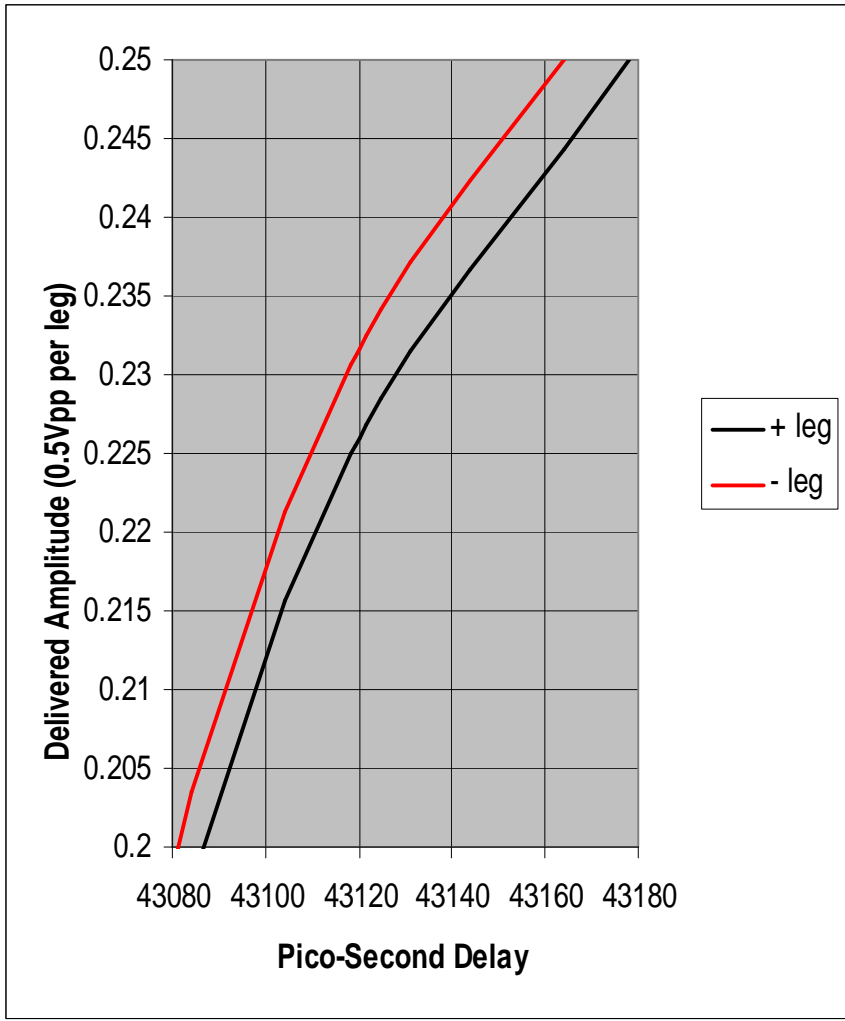

Skew At Position With Less Slope (Bulk Cable Only)

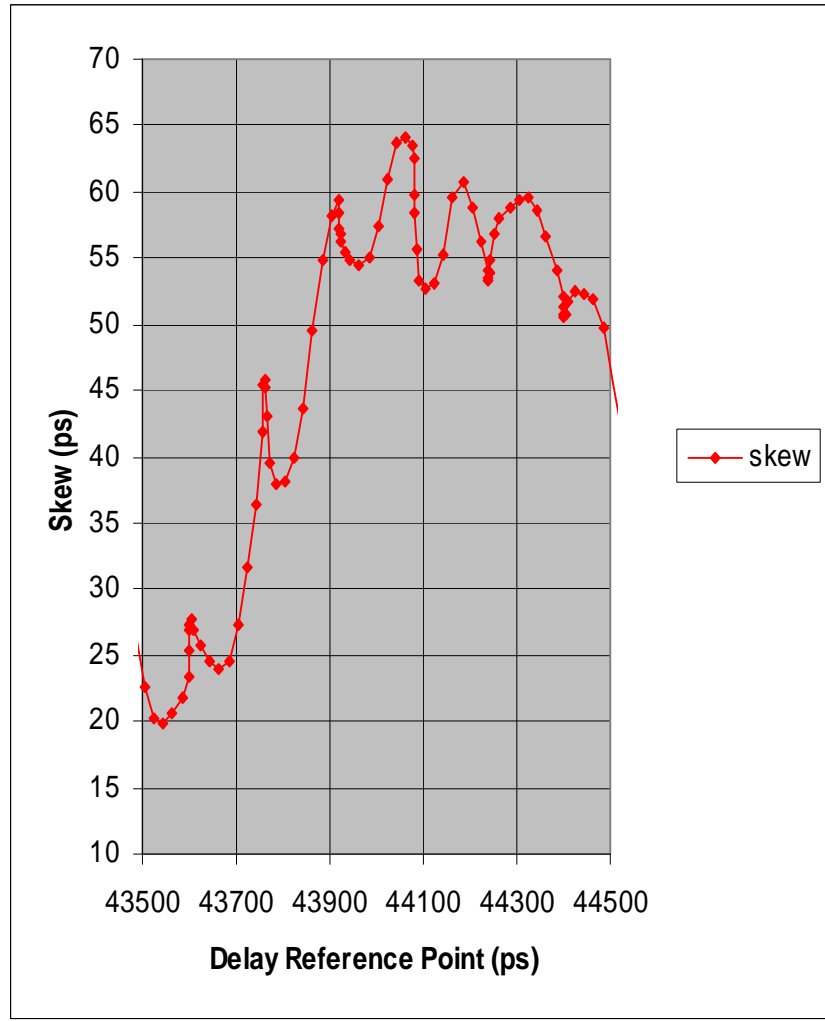
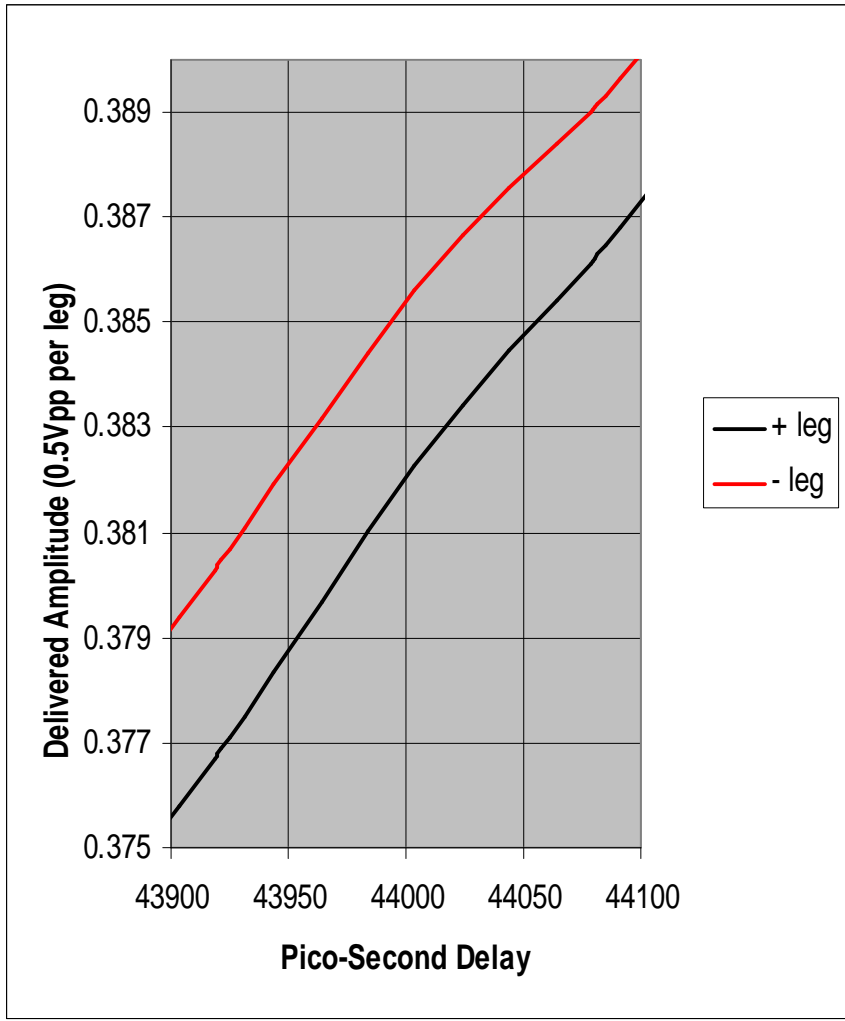

Skew And UI Relationship (Bulk Cable Only)

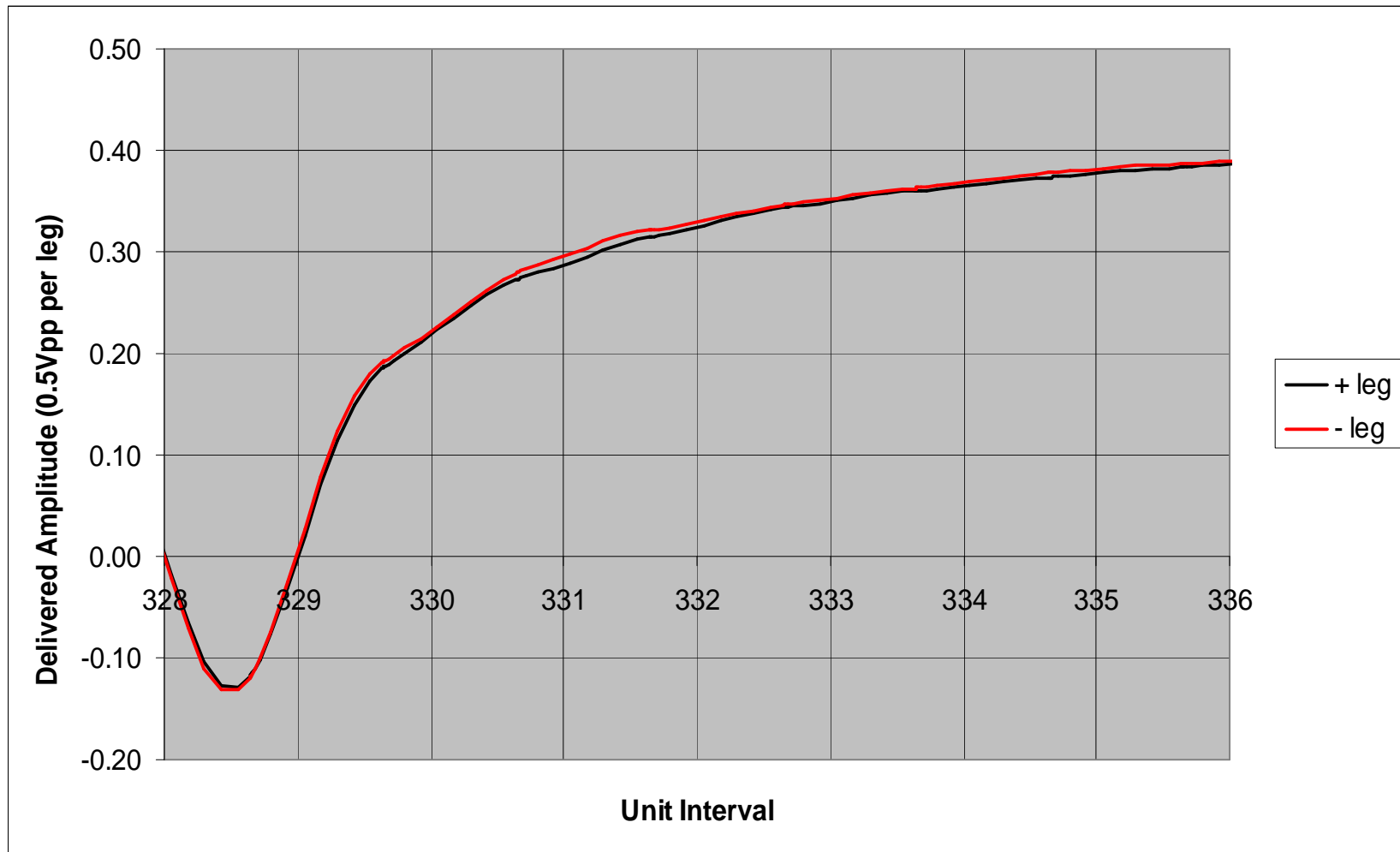

Mismatch & Skew Measurements



- Amplitude mismatch due to unequal distortion of the delivered differential signal occurs at several UI after the last transition. We interpret this error as a delay mismatch by the skew measurement.
- The skew observed at UI 331 is large ($\sim 0.25\text{UI}$) but will have little effect on signaling margins in a region with no transitions
- Will the amplitude mismatch at UI 331 induce a similar skew with a transition region superimposed?

Skew In Transition Region (Bulk Cable Only)

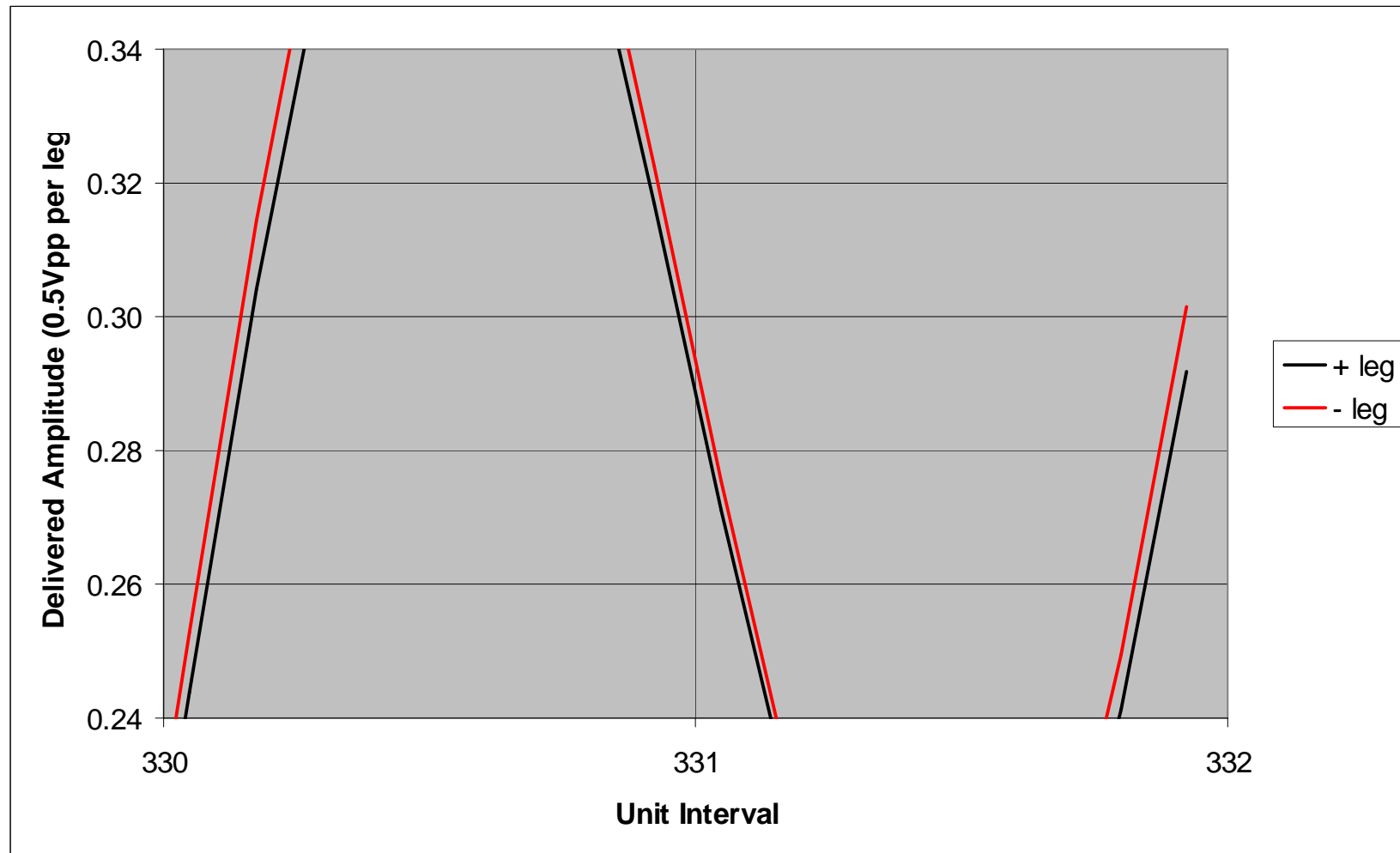

Realistic Single Drain Termination



- The termination method was altered to replicate a realistic single drain termination and analysis repeated

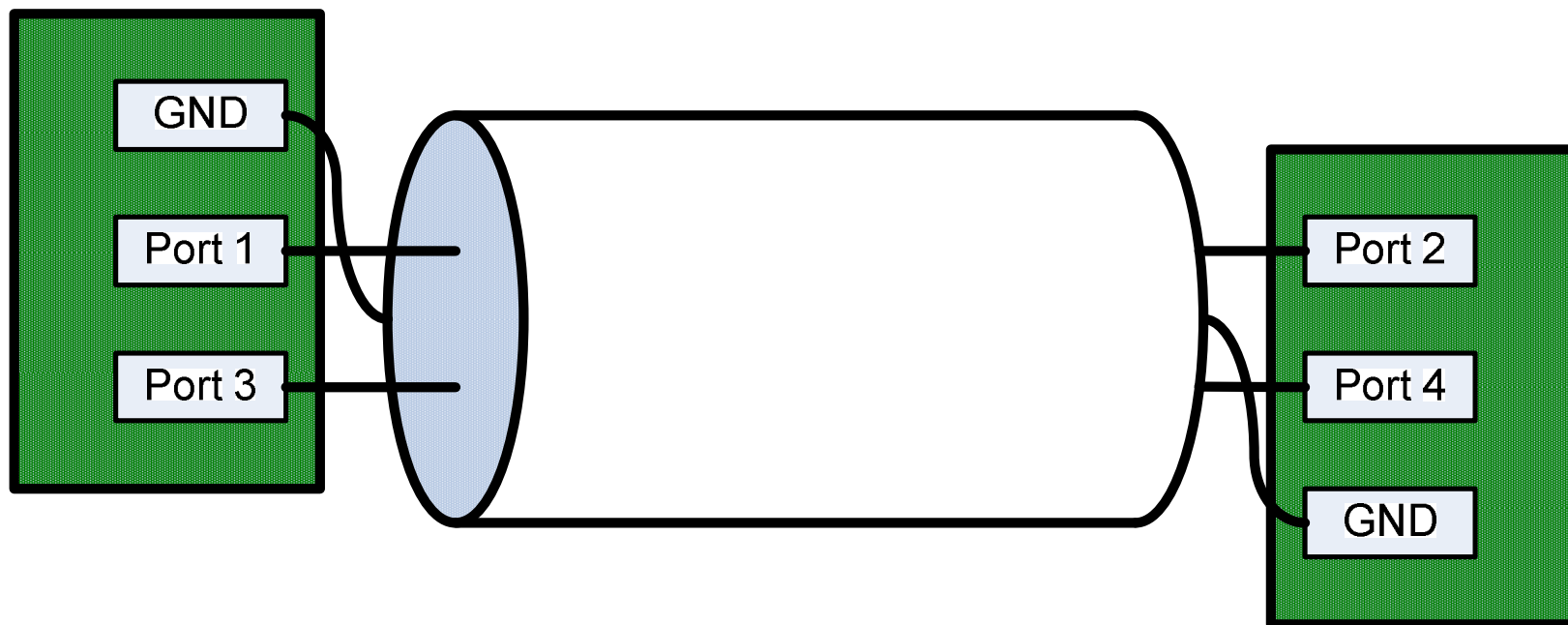

Time Domain Imbalance



- Using this termination method, a mismatch of nearly 20% of the average peak-to-peak value was obtained with simulations

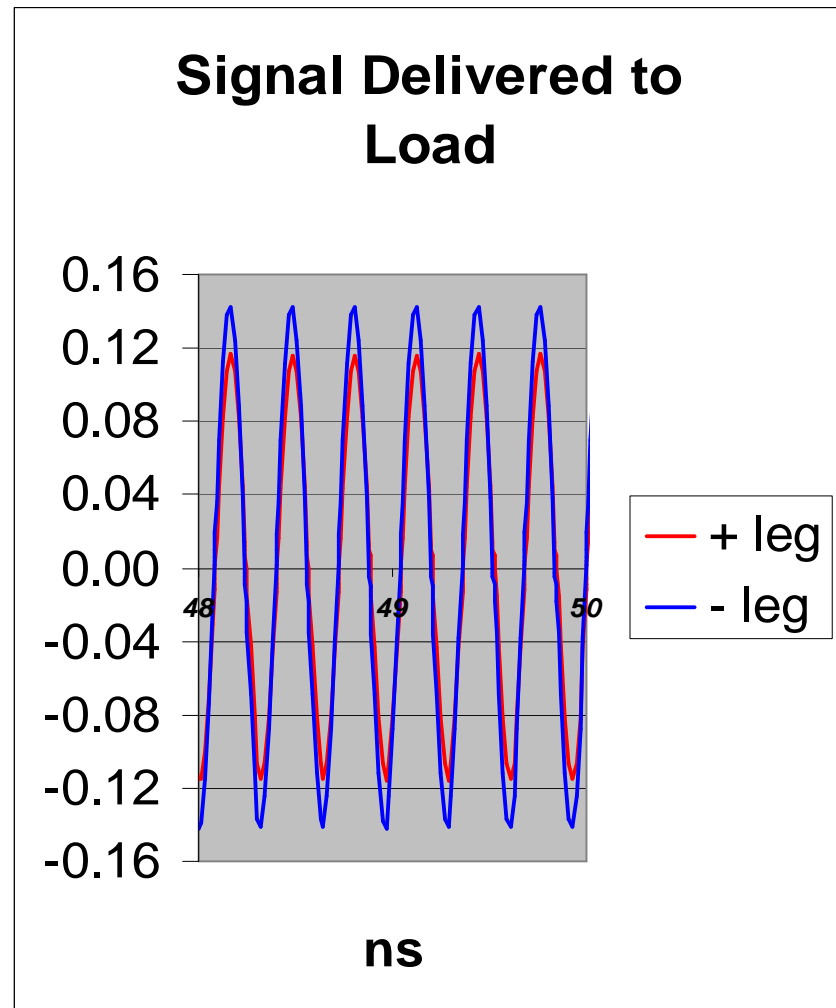
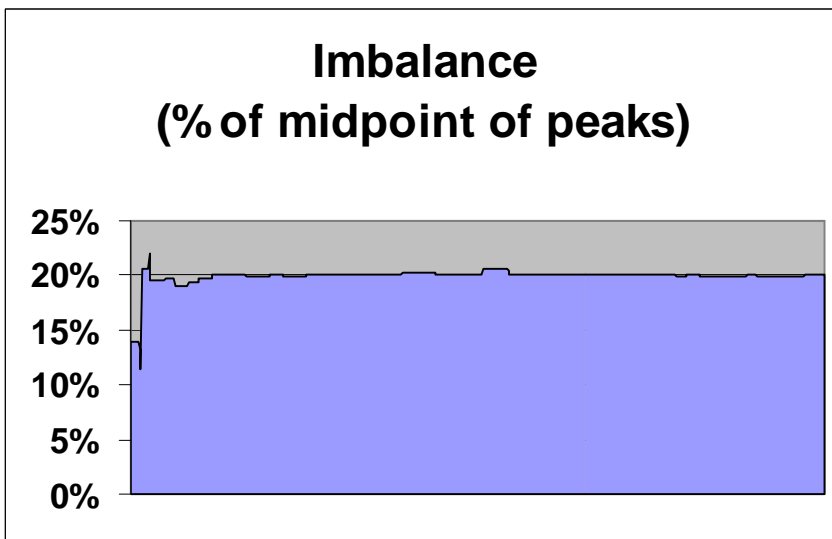

Mismatch in Frequency Domain

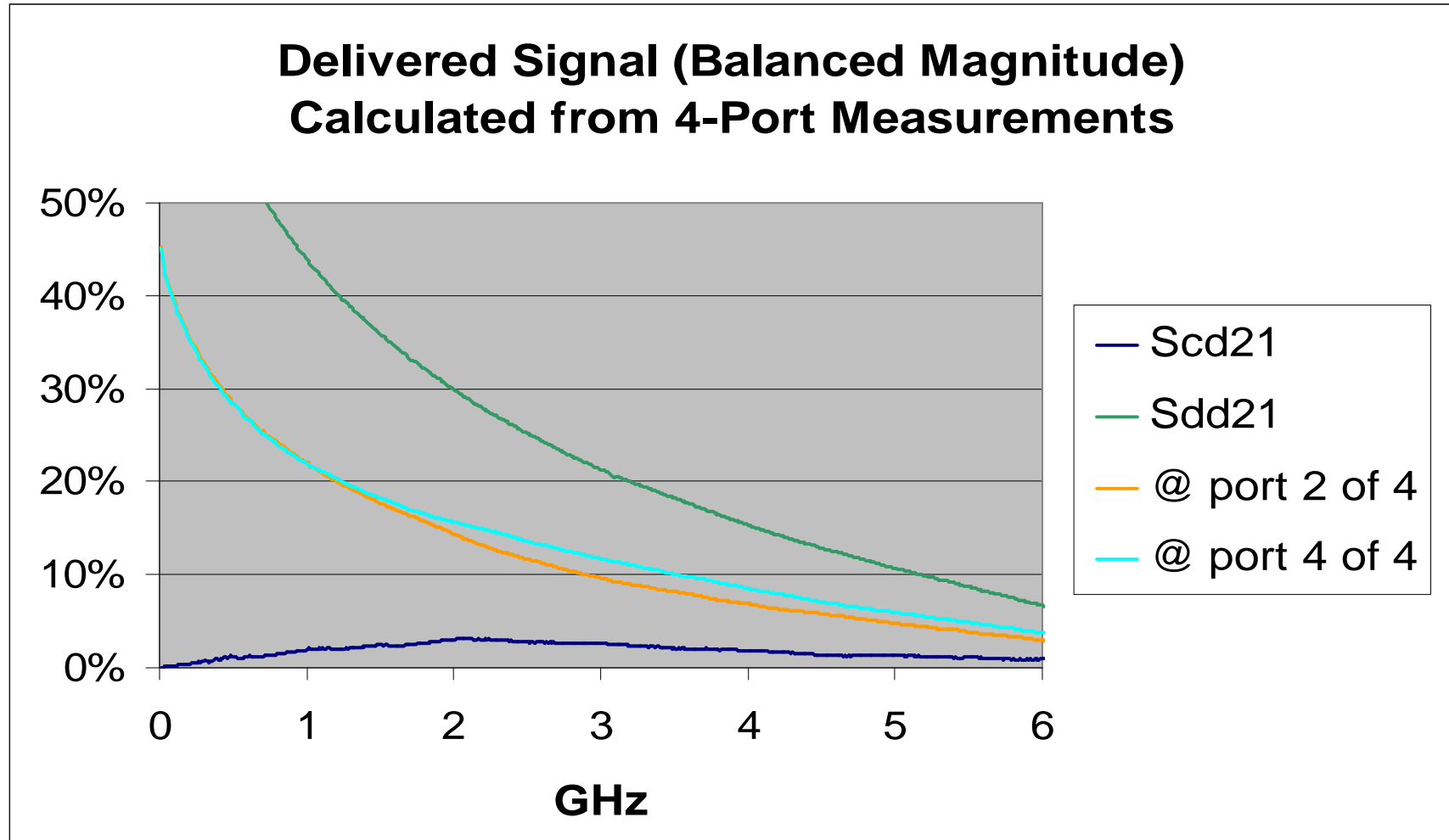

$$S_{2 \text{ from } _ \text{port1 and 3}} = 0.5 * (S_{21} - S_{23}) \quad S_{4 \text{ from } _ \text{ports1 \& 3}} = 0.5 * (S_{43} - S_{41})$$

Mismatch & Skew Measurements



- Insertion loss plots of individual legs within the pair also show imbalance.
- Scd21 peaks at approximately 3%. This amount is far smaller than the 20% peak-to-peak value measured in the bit amplitude. To understand why, you must consider the 80% reduction in the differential amplitude across the interconnect.

Four Port Perspective



- Thru terms S_{21} and S_{43} match very closely
- Cross coupled terms S_{23} and S_{41} differ
- Also note cross coupled term S_{41} has a lower loss than thru terms S_{21} and S_{43}

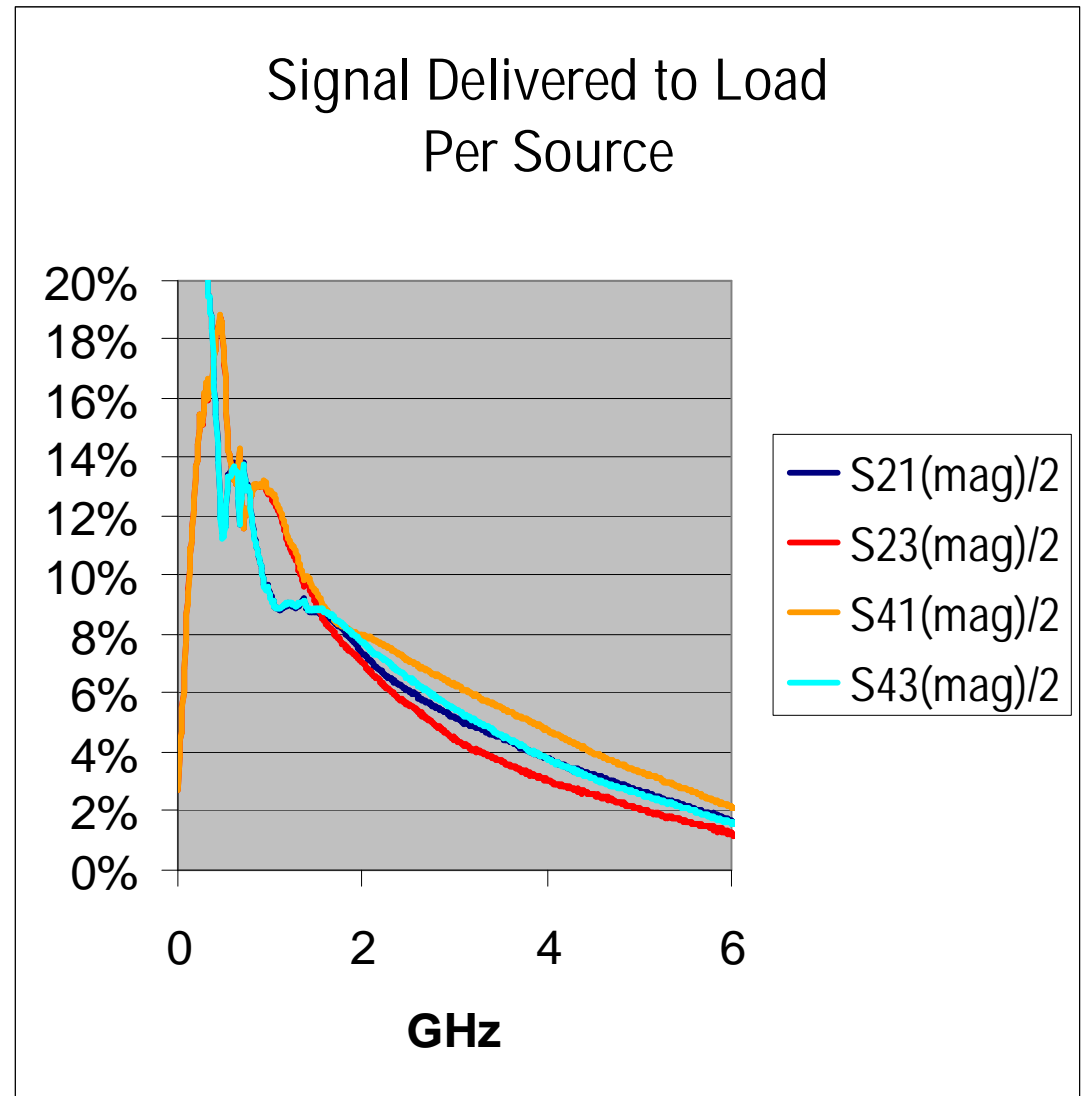

Single Drain Termination Issues



- The four components of S_{DD21} and S_{CD21} in order from lowest insertion loss at 3GHz to highest are S_{41} , S_{43} , S_{21} and S_{23}

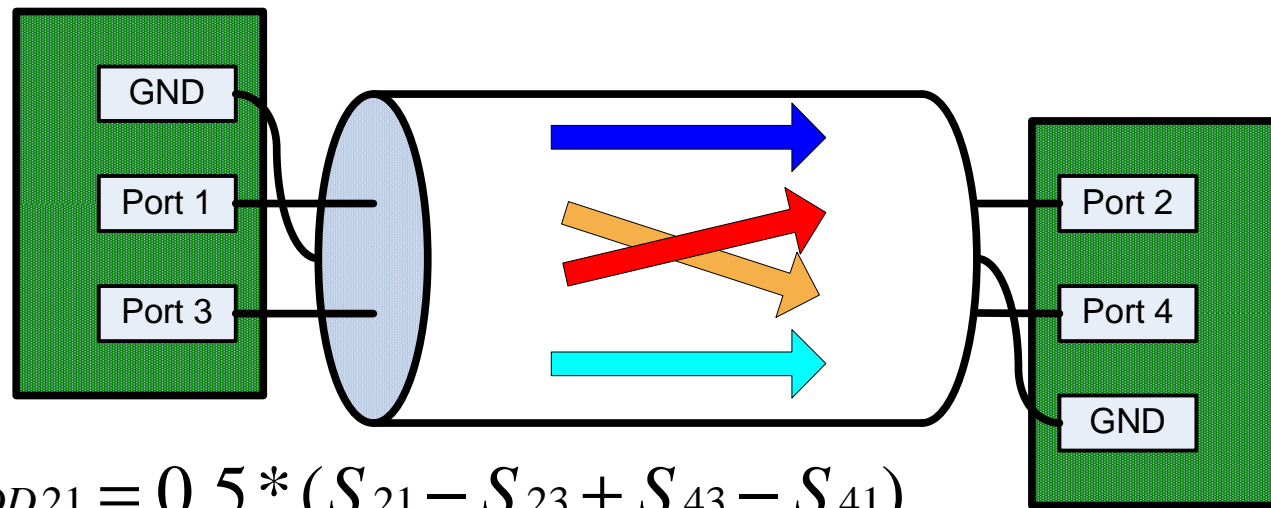

$$S_{DD21} = 0.5 * (S_{21} - S_{23} + S_{43} - S_{41})$$

$$S_{CD21} = 0.5 * (S_{21} - S_{23} - S_{43} + S_{41})$$

Induced Return Current



- The return current through the twin-axial foil and far end connector interface is related to Scd21. Using the single drain design with side-termination technique previously shown the current can be estimated. I have assumed negligible insertion loss on cable and 1200mVpp differential signaling.

Scd21(dB)	Twinax (mApp)	Far End Connector (mApp)	Twinax (mArms)	Far End Connector (mArms)
-10	3.8	7.6	1.34	2.68
-20	1.2	2.4	0.42	0.85
-26	0.6	1.2	0.21	0.43
-30	0.4	0.8	0.13	0.27
-40	0.1	0.2	0.04	0.08

(600mVpp per leg results in 12mApp per leg)

Mismatch and Receiver Margin



- How does intra-pair amplitude mismatch reduce receiver margins?
- Will the termination method be an issue?
- Does common mode signal levels of (~20%) create a new problem for the receiver?

Scd21 and Return Currents



- Does Scd21 provide an accurate estimate of emissions?
- Half of the mismatch occurs at each termination point. Scd21 will be an indicator of how much current flows on the return foil and is injected into the connector interface at the far end.
- However, those two are different and vary with cable loss.

S-Parameter Postings



- The rev 4 posting includes touchstone files of both 24AWG 10m bulk cable termination methods
- Side-termination is identified at method #2
- Shown below are the port assignments

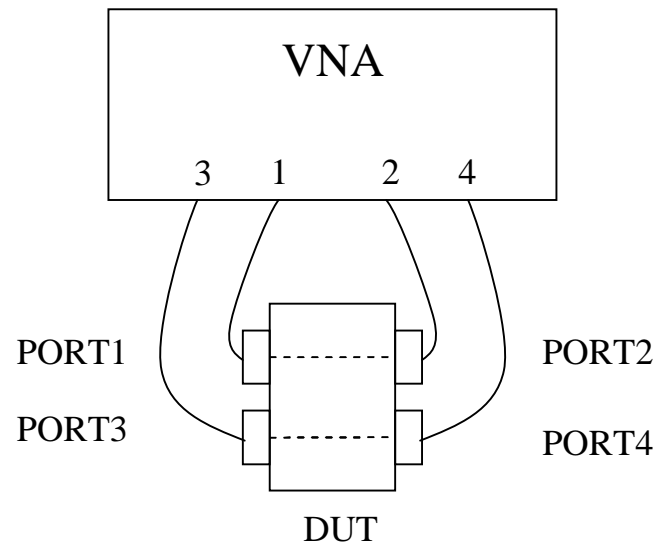

Cable Assembly Data



- External miniSAS samples from three different vendors were measured. Sample lengths consisted of 0.5, 1, 2, 4 and 6 meters. Two pairs were examined from each cable resulting in 20 measurements for each vendor.
- Histograms of the measured Scd21 and imbalance are then used to characterize typical product

Scd21 Histogram for 3GHz

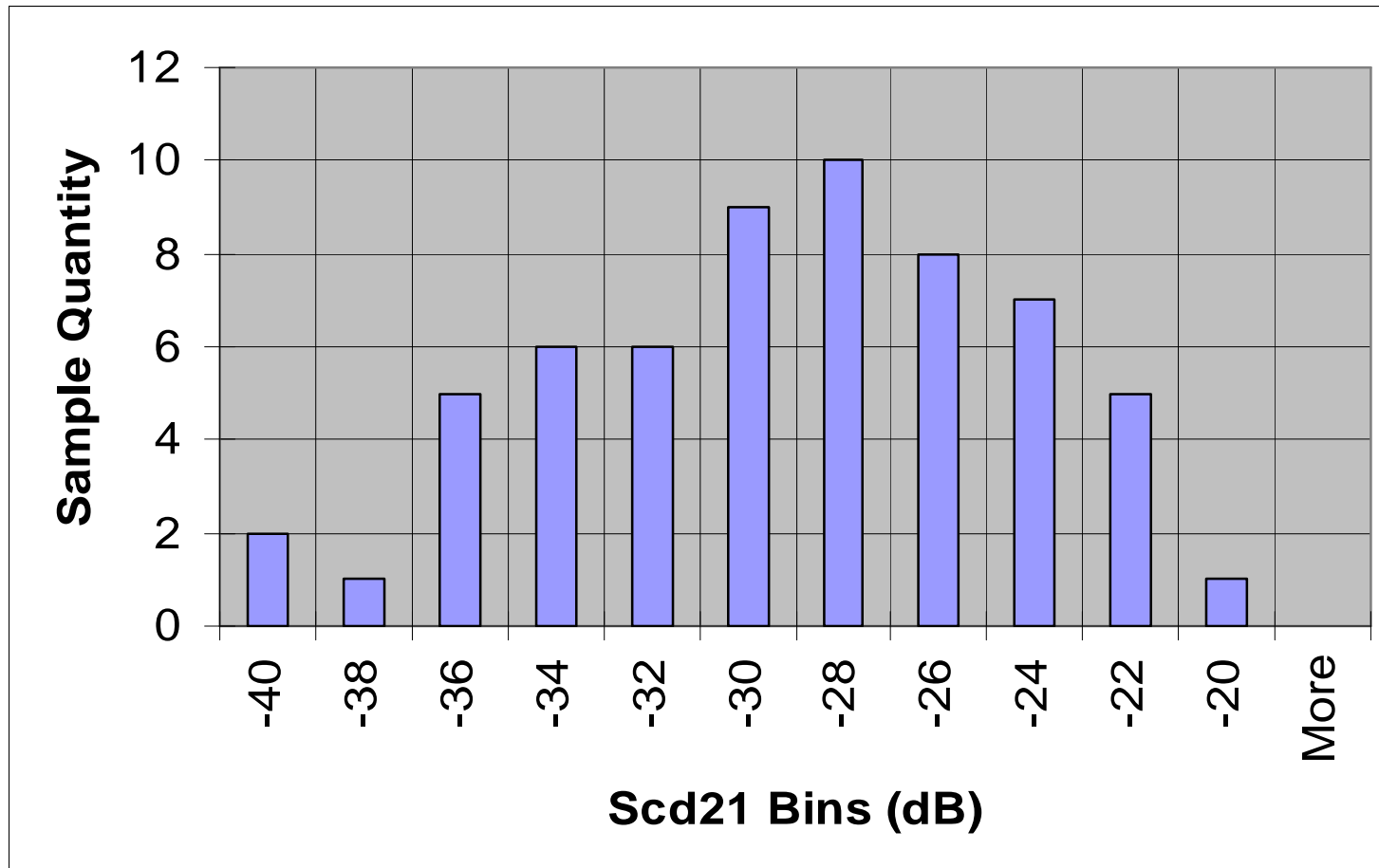

Note, bin boundary for -20dB extends from -20dB to -22dB ... etc.

Scd21 Histogram for 6GHz

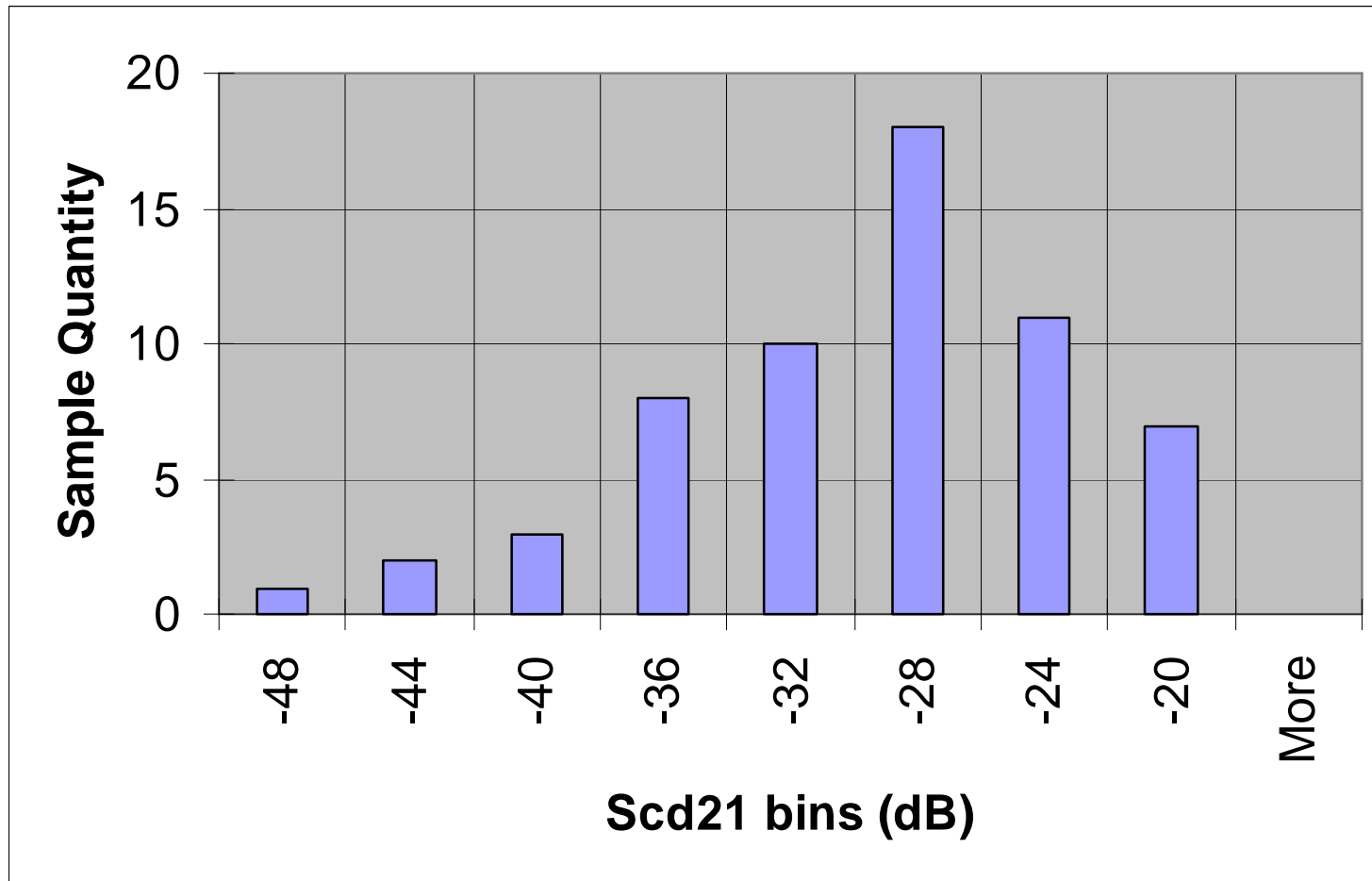

Histogram of Mismatch at 3GHz

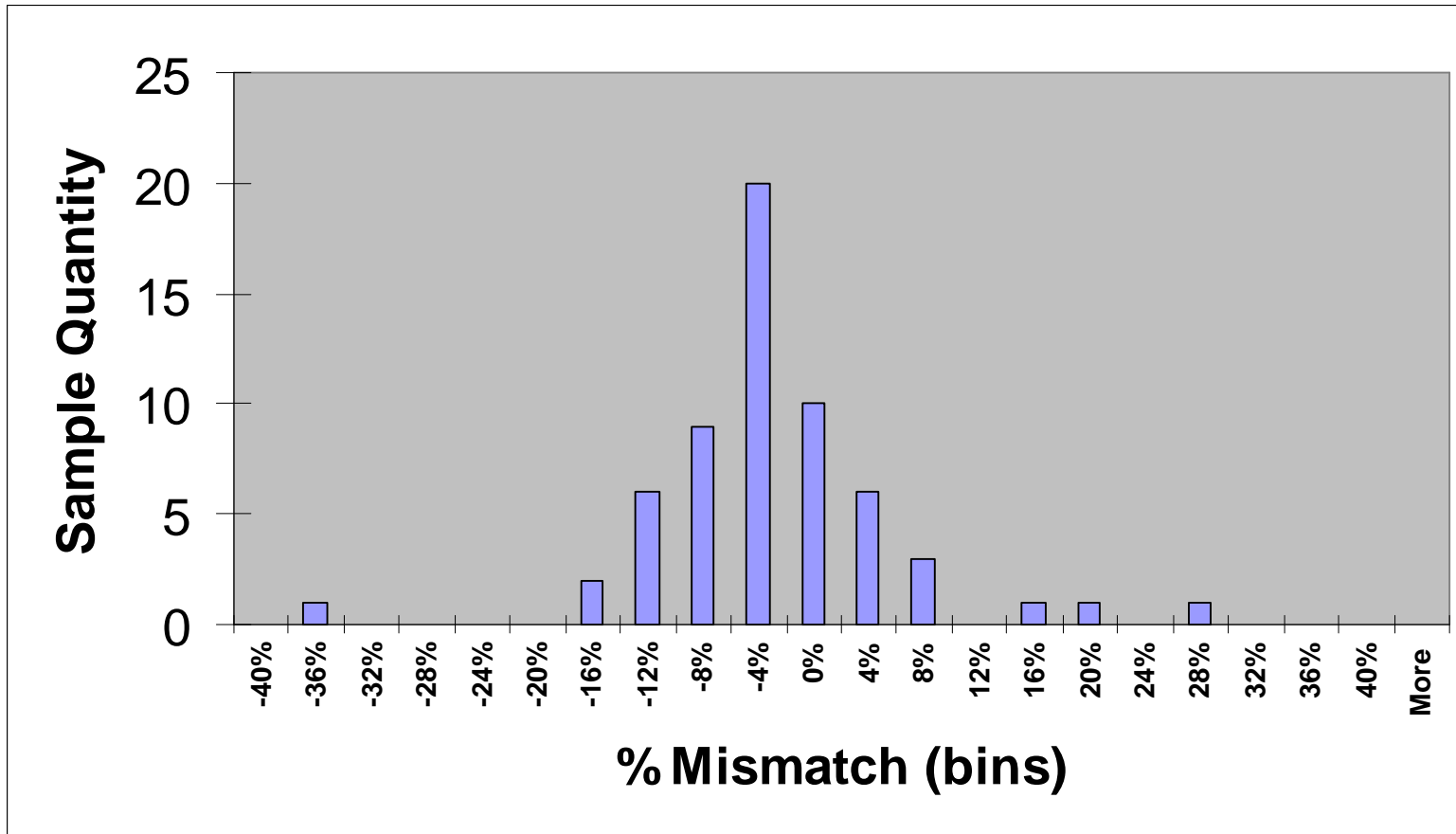

Scd21 @3GHz vs. Cable Length

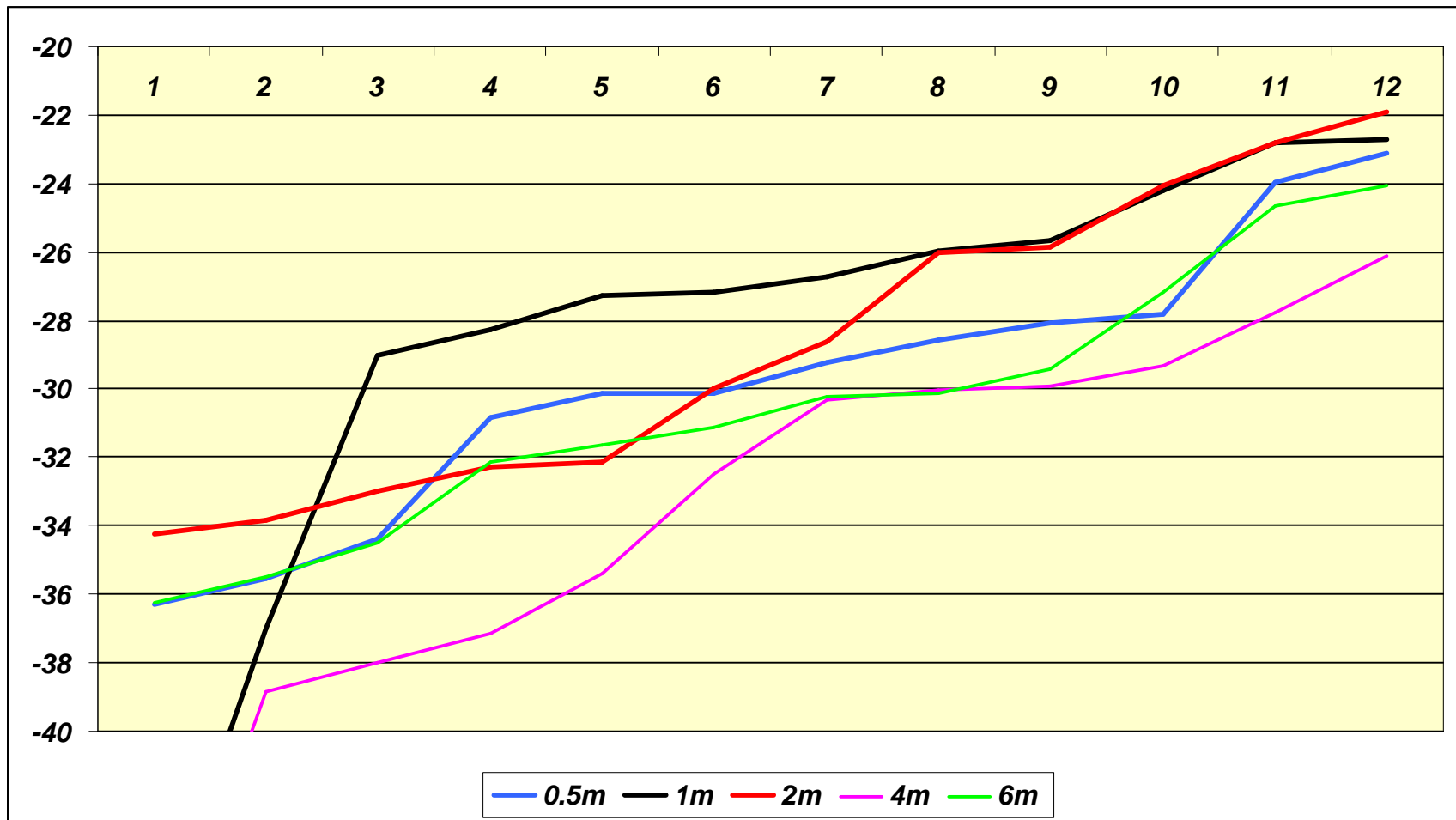

Cable Assembly Data



- Bell curves imply sample size is adequate
- Mismatch (%) between + and – legs is slightly skewed to the negative side. Need additional data to make any conclusions. Also should consider alternate test boards
- Cable length does not appear to be a dominant factor
- Plan to compare return current effects of Scd21 and transmitter specifications for mismatch

