

30 October 2006

06-324r7 SAS-2 Modifications to the SAS Speed Negotiation

To: T10 Technical Committee
From: Amr Wassal, PMC-Sierra (amr_wassal@pmc-sierra.com)
Stephen Finch, STMicroelectronics (steve.finch@st.com)
Date: 20 September 2006
Subject: 06-324r7 SAS-2 Modifications to the SAS Speed Negotiation

Revision history

Revision 0 (7 July 2006) First revision

Revision 1 (24 August 2006)

Revision 2 (7 September 2006) Review updates including: training pattern definition, changes to several diagrams where training pattern is depicted and state machine.

Revision 3 (20 September 2006) Updates based on 12 September 2006 Phy Working Group meeting. A significant re-organization, plus many changes to make consistent use of new terms like Final-SNW and Train-SNW. Updates to diagrams.

Revision 4 (29 September 2006) Updates per 28 September 2006 conference call.

Revision 5 (12 October 2006) Updates per 12 October 2006 conference call.

Revision 6 (19 October 2006) Updates per 19 October 2006 conference call. We reviewed down to the middle of section 6.7.4.2.4.

Revision 7 (30 October 2006) Updates per 26 October 2006 conference call. We reviewed down to the middle of section 6.7.4.2.4. Incorporated that portion of 06-363 relating to changes in clause 6 into this document and that content will be reviewed and updated as part of this document into the future.

Related documents

sas2r04a - Serial Attached SCSI - 2 (SAS-2) revision 4a

05-397 SAS-2 Start-up training sequence (Harvey Newman, Infineon)

06-263 SAS-2 Spread-spectrum clocking (Rob Elliott, HP)

06-295 SAS-2 Speed negotiation (Amr Wassal and Robert Watson, PMC-Sierra)

06-354 SAS-2 Startup training sequence proposal (Steve Finch, ST Microelectronics)

06-355 SAS-2 SNW-3 definition (Amr Wassal and Robert Watson, PMC-Sierra)

06-363 SAS-2 SNW-3 bit definitions (Rob Elliot, HP)

Overview

The SAS speed negotiation defined in SAS-1 did not allow for training of the phy nor allow for exchange of parameters that are proving useful at G3 and higher rates. New proposals for SAS-2 proposed a training pattern in 05-397 and speed negotiation modifications in 06-295 that has provision for training and for exchanging parameters during SNW-3 as defined in 06-363.

[Suggested additions to clause 3 Definitions, symbols, abbreviations, keywords, and conventions \(changes added first in 06-324r4\). No changes to existing clause 3 content.](#)

3.1 Definitions

3.1.x Actual Lock Time (ALT): The time at which actual lock to the received ALIGN (0) or ALIGN (1) occurs and the transmitter transitions from sending ALIGN (0) to sending ALIGN (1) (see 6.7.4.2.2).

3.1.x Actual Training Time (ATT): The time in which training of the phy's receiver is complete (see 6.7.4.2.2).

3.1.x Bit Cell Time (BCCT): The time period defined within an SNW-3 during which one bit phy capabilities is transmitted (see 6.7.4.2.2).

Deleted: window

3.1.x Maximum Training Time (MTT): The maximum time for training to complete during a Train-SNW (see 6.7.4.2.2).

Deleted: ing

3.1.x Maximum Train-SNW Window Time (MTWT): The maximum duration of the Train-SNW (see 6.7.4.2.2).

Deleted: window

3.1.x Training Lock Time (TLT): The maximum time during Train-SNW for a transmitter device to reply with TRAIN_DONE pattern.

3.1.x Train-SNW Window Time (TWT): The actual duration of the Train-SNW.

3.2 Symbols and abbreviations

ALT	Actual lock time
ATT	Actual training time
MTT	Maximum training time
MTWT	Maximum Train-SNW window time
SNW	Speed negotiation window
SNWT	Speed negotiation window time
TLT	<u>Training lock time</u>
TWT	<u>Train-SNW window time</u>

Suggested changes to clause 7 (Link Layer): Add definitions for TRAIN and TRAIN_DONE primitives. All changes are additions of blue text. No changes to existing clause 7 content.

7.2.2 Primitive summary

Table 84 defines the primitives not specific to the type of connection.

Table 84 — Primitives not specific to type of connection (part 1 of 2)

Primitive	Use ^a	From ^b			To ^b			Primitive sequence type ^c
		I	E	T	I	E	T	
AIP (NORMAL)	NoConn		E					Extended
AIP (RESERVED 0)								
AIP (RESERVED 1)								
AIP (RESERVED 2)								
AIP (RESERVED WAITING ON PARTIAL)					I	E	T	
AIP (WAITING ON CONNECTION)				E				
AIP (WAITING ON DEVICE)				E				
AIP (WAITING ON PARTIAL)				E				
ALIGN (0)	All							Single
ALIGN (1)		I	E	T	I	E	T	
ALIGN (2)								
ALIGN (3)								
BREAK	All	I	E	T	I	E	T	Redundant
BREAK_REPLY	All	I	E	T	I	E	T	Redundant
BROADCAST (CHANGE)	NoConn	I	E		I			Redundant
BROADCAST (SES)				T	I			
BROADCAST (EXPANDER)			E		I			
BROADCAST (ASYNCHRONOUS EVENT)				T	I			
BROADCAST (ZONE ACTIVATE)		I				E		
BROADCAST (RESERVED 4)								
BROADCAST (RESERVED CHANGE 0)					I			
BROADCAST (RESERVED CHANGE 1)					I			
CLOSE (CLEAR AFFILIATION)	STP	I					T	Triple
CLOSE (NORMAL)	Conn	I		T			T	
CLOSE (RESERVED 0)					I			
CLOSE (RESERVED 1)								
EOAF	NoConn	I	E	T	I	E	T	Single
ERROR	All		E		I	E	T	Single
HARD_RESET	NoConn	I	E		I	E	T	Redundant

Primitive	Use ^a	From ^b			To ^b			Primitive sequence type ^c
		I	E	T	I	E	T	
NOTIFY (ENABLE SPINUP)	All	I	E				T	Single
NOTIFY (POWER LOSS EXPECTED)		I	E				T	
NOTIFY (RESERVED 1)								
NOTIFY (RESERVED 2)					I	E	T	
OPEN_ACCEPT	NoConn	I		T	I		T	Single

Table 84 — Primitives not specific to type of connection (part 2 of 2)

Primitive	Use ^a	From ^b			To ^b			Primitive sequence type ^c		
		I	E	T	I	E	T			
OPEN_REJECT (BAD DESTINATION)	NoConn		E					Single		
OPEN_REJECT (CONNECTION RATE NOT SUPPORTED)		I	E	T						
OPEN_REJECT (NO DESTINATION)			E							
OPEN_REJECT (PATHWAY BLOCKED)			E							
OPEN_REJECT (PROTOCOL NOT SUPPORTED)		I		T						
OPEN_REJECT (ZONE VIOLATION)			E							
OPEN_REJECT (RESERVED ABANDON 1)					I		T			
OPEN_REJECT (RESERVED ABANDON 2)										
OPEN_REJECT (RESERVED ABANDON 3)										
OPEN_REJECT (RESERVED CONTINUE 0)										
OPEN_REJECT (RESERVED CONTINUE 1)										
OPEN_REJECT (RESERVED INITIALIZE 0)										
OPEN_REJECT (RESERVED INITIALIZE 1)										
OPEN_REJECT (RESERVED STOP 0)										
OPEN_REJECT (RESERVED STOP 1)										
OPEN_REJECT (RETRY)		I	E	T						
OPEN_REJECT (STP RESOURCES BUSY)			E	T						
OPEN_REJECT (WRONG DESTINATION)	I		T					T		
SOAF	NoConn	I	E	T		I		E	T	Single
TRAIN	SpNeg	I	E	T		I		E	T	Redundant
TRAIN_DONE	SpNeg	I	E	T		I		E	T	Redundant

^a The Use column indicates when the primitive is used:
a) NoConn: SAS physical links, outside connections;
b) Conn: SAS physical links, inside connections;
c) All: SAS physical links, both outside connections or inside any type of connection; or
d) STP: SAS physical links, inside STP connections.
e) SpNeg: SAS physical links, during speed negotiation (see 6.7.4.2)

^b The From and To columns indicate the type of ports that originate each primitive or are the intended destinations of each primitive:
a) I for SAS initiator ports;
b) E for expander ports; and
c) T for SAS target ports.
Expander ports are not considered originators of primitives that are passing through from expander port to expander port.

^c The Primitive sequence type columns indicate whether the primitive is sent as a single primitive sequence, a repeated primitive sequence, a continued primitive sequence, an extended primitive sequence, a triple primitive sequence, or a redundant primitive sequence (see 7.2.4).

7.2.3 Primitive encodings

Table 87 defines the primitive encoding for primitives not specific to type of connection.

Table 87 — Primitive encoding for primitives not specific to type of connection (part 1 of 2)

Primitive	Character			
	1 st	2 nd	3 rd	4 th (last)
AIP (NORMAL)	K28.5	D27.4	D27.4	D27.4
AIP (RESERVED 0)	K28.5	D27.4	D31.4	D16.7
AIP (RESERVED 1)	K28.5	D27.4	D16.7	D30.0
AIP (RESERVED 2)	K28.5	D27.4	D29.7	D01.4
AIP (RESERVED WAITING ON PARTIAL)	K28.5	D27.4	D01.4	D07.3
AIP (WAITING ON CONNECTION)	K28.5	D27.4	D07.3	D24.0
AIP (WAITING ON DEVICE)	K28.5	D27.4	D30.0	D29.7
AIP (WAITING ON PARTIAL)	K28.5	D27.4	D24.0	D04.7
ALIGN (0)	K28.5	D10.2	D10.2	D27.3
ALIGN (1)	K28.5	D07.0	D07.0	D07.0
ALIGN (2)	K28.5	D01.3	D01.3	D01.3
ALIGN (3)	K28.5	D27.3	D27.3	D27.3
BREAK	K28.5	D02.0	D24.0	D07.3
BREAK_REPLY	K28.5	D02.0	D29.7	D16.7
BROADCAST (CHANGE)	K28.5	D04.7	D02.0	D01.4
BROADCAST (SES)	K28.5	D04.7	D07.3	D29.7
BROADCAST (EXPANDER)	K28.5	D04.7	D01.4	D24.0
BROADCAST (ASYNCHRONOUS EVENT)	K28.5	D04.7	D04.7	D04.7
BROADCAST (ZONE ACTIVATE)	K28.5	D04.7	D16.7	D02.0
BROADCAST (RESERVED 4)	K28.5	D04.7	D29.7	D30.0
BROADCAST (RESERVED CHANGE 0)	K28.5	D04.7	D24.0	D31.4
BROADCAST (RESERVED CHANGE 1)	K28.5	D04.7	D27.4	D07.3
CLOSE (CLEAR AFFILIATION)	K28.5	D02.0	D07.3	D04.7
CLOSE (NORMAL)	K28.5	D02.0	D30.0	D27.4
CLOSE (RESERVED 0)	K28.5	D02.0	D31.4	D30.0
CLOSE (RESERVED 1)	K28.5	D02.0	D04.7	D01.4
EOAF	K28.5	D24.0	D07.3	D31.4
ERROR	K28.5	D02.0	D01.4	D29.7
HARD_RESET	K28.5	D02.0	D02.0	D02.0

Table 87 — Primitive encoding for primitives not specific to type of connection (part 2 of 2)

Primitive	Character			
	1 st	2 nd	3 rd	4 th (last)
NOTIFY (ENABLE SPINUP)	K28.5	D31.3	D31.3	D31.3
NOTIFY (POWER LOSS EXPECTED)	K28.5	D31.3	D07.0	D01.3
NOTIFY (RESERVED 1)	K28.5	D31.3	D01.3	D07.0
NOTIFY (RESERVED 2)	K28.5	D31.3	D10.2	D10.2
OPEN_ACCEPT	K28.5	D16.7	D16.7	D16.7
OPEN_REJECT (BAD DESTINATION)	K28.5	D31.4	D31.4	D31.4
OPEN_REJECT (CONNECTION RATE NOT SUPPORTED)	K28.5	D31.4	D04.7	D29.7
OPEN_REJECT (NO DESTINATION)	K28.5	D29.7	D29.7	D29.7
OPEN_REJECT (PATHWAY BLOCKED)	K28.5	D29.7	D16.7	D04.7
OPEN_REJECT (PROTOCOL NOT SUPPORTED)	K28.5	D31.4	D29.7	D07.3
OPEN_REJECT (ZONE VIOLATION)	K28.5	D31.4	D02.0	D27.4
OPEN_REJECT (RESERVED ABANDON 1)	K28.5	D31.4	D30.0	D16.7
OPEN_REJECT (RESERVED ABANDON 2)	K28.5	D31.4	D07.3	D02.0
OPEN_REJECT (RESERVED ABANDON 3)	K28.5	D31.4	D01.4	D30.0
OPEN_REJECT (RESERVED CONTINUE 0)	K28.5	D29.7	D02.0	D30.0
OPEN_REJECT (RESERVED CONTINUE 1)	K28.5	D29.7	D24.0	D01.4
OPEN_REJECT (RESERVED INITIALIZE 0)	K28.5	D29.7	D30.0	D31.4
OPEN_REJECT (RESERVED INITIALIZE 1)	K28.5	D29.7	D07.3	D16.7
OPEN_REJECT (RESERVED STOP 0)	K28.5	D29.7	D31.4	D07.3
OPEN_REJECT (RESERVED STOP 1)	K28.5	D29.7	D04.7	D27.4
OPEN_REJECT (RETRY)	K28.5	D29.7	D27.4	D24.0
OPEN_REJECT (STP RESOURCES BUSY)	K28.5	D31.4	D27.4	D01.4
OPEN_REJECT (WRONG DESTINATION)	K28.5	D31.4	D16.7	D24.0
SOAF	K28.5	D24.0	D30.0	D01.4
TRAIN	K28.5	D30.3	D30.3	D30.3
TRAIN_DONE	K28.5	D30.3	D30.3	D10.2

The following are added clauses:

7.2.5.14 TRAIN

TRAIN is used during speed negotiation (see 6.7.4.2).

7.2.5.15 TRAIN_DONE

TRAIN_DONE is used during speed negotiation (see 6.7.4.2).

Suggested changes to clause 6.6.2. No other changes to clause 6.6. All changes are additions of blue text.

6.6.2 Transmitting OOB signals

Table 73 — OOB signal transmitter device requirements

Signal	Burst time	Idle time	Negation time	Signal time ^g
COMWAKE	160 OOB ^a	160 OOB ^a	280 OOB ^b	2200 OOB ^h
COMINIT/RESET	160 OOB ^a	480 OOB ^c	800 OOB ^d	4600 OOB ⁱ
COMSAS	160 OOB ^a	1 440 OOB ^e	2 400 OOB ^f	12000 OOB ^j

^a 160 OOB is nominally 106,6 ns (see table 72).
^b 280 OOB is nominally 186,6 ns.
^c 480 OOB is nominally 320 ns.
^d 800 OOB is nominally 533 ns.
^e 1 440 OOB is nominally 960 ns.
^f 2 400 OOB is nominally 1 600 ns.
^g Signal time is defined as the total of six Burst times plus six Idle times plus one Negation time (see description below).
^h 2 200 OOB is nominally 1 467 ns.
ⁱ 4 600 OOB is nominally 3 093 ns.
^j 12 000 OOB is nominally 8 000 ns.

Clause 6.7.4.2 is replaced in its entirety. Previously reviewed text is shown in black rather than being changed to blue.

6.7.4.2 SAS speed negotiation sequence

6.7.4.2.1 SAS speed negotiation sequence overview

The speed negotiation sequence establishes communications between the two phys of a physical link at the highest possible transmission rate.

The SAS speed negotiation sequence is a peer-to-peer negotiation technique that does not assume initiator and target (i.e., host and device) roles. The rules for speed negotiation are the same for both phys of a physical connection.

The speed negotiation sequence consists of a set of speed negotiation windows. Each speed negotiation window is identified by a name (e.g., Speed Negotiation Window 1 or SNW-1) that is used to identify the format, the timing of any transmissions within the window, and the transmission rate.

Speed negotiation windows conform to one of three defined formats:

- a) Speed negotiation without training. SNW-1, SNW-2 and Final-SNW are of this type.
- b) Speed negotiation with training. Train-SNW is of this type.
- c) Link Capabilities Exchange. SNW-3 is of this type.

Deleted: ing

The speed negotiation window formats are defined in 6.7.4.2.3.

Many of the timing parameters used for defining the speed negotiation windows are common to multiple window types. All of the timing specifications for all speed negotiation window types are defined in section 6.7.4.2.2.

A SAS speed negotiation sequence may or may not include all three types of speed negotiation windows. Phys may implement a subset of speed negotiation windows provided that the subset implements a valid speed negotiation sequence. Speed negotiation sequences are defined in section 6.7.4.2.4.

6.7.4.2.2 Speed Negotiation Timing Specifications

Table 80 defines the timing specifications for the SAS speed negotiation windows. The definitions of the speed negotiation window types specify the timing parameters that are applicable for that type.

Deleted: Table 80

Table 80 — SAS speed negotiation sequence timing specifications

Acronym	Name	Time ^a	Comments
RCDT	Rate change delay time	750 000 OOBI ^b	The time the transmitter device shall transmit D.C. idle between rates during speed negotiation.
SNTT	Speed negotiation transmit time	163 840 OOBI ^c	The time during which ALIGN (0) or ALIGN (1) is transmitted at each physical link rate during the speed negotiation sequence.
SNLT	Speed negotiation lock time	153 600 OOBI ^d	The maximum time during SNW-1, SNW-2 or Final-SNW for a transmitter device to reply with ALIGN (1).
ALT	Actual lock time		The time at which actual lock to the received ALIGN (0) or ALIGN (1) occurs and the transmitter transitions from sending ALIGN (0) to sending ALIGN (1).
SNWT	Speed negotiation window time	913 840 OOBI ^e	The duration of SNW-1, SNW-2, SNW-3, or a Final-SNW.
MTT	Maximum training time	29 998 080 OOBI ^f	The maximum time for training to complete during a Train-SNW.
TLT	Training lock time	29 985 280 OOBI ^g	The maximum time during Train-SNW for a transmitter device to reply with TRAIN_DONE pattern.
ATT	Actual training time		The time in which training of the phy's receiver is complete.
TWT	Train-SNW window time		The actual duration of the Train-SNW. The duration of the Train-SNW may be less than MTWT if the Train-SNW is valid, or will be equal to MTWT if the Train-SNW is invalid.
MTWT	Maximum Train-SNW window time	30 748 080 OOBI ^h	The maximum duration of the Train-SNW. The duration of the Train-SNW may be less than MTWT.
BCT	Bit Cell Time	2 200 OOBI	Each BCT is either a COMWAKE or D.C. Idle.

Deleted: MTT

[1]

^a OOBI is defined in table 67.

^b 750 000 OOBI is nominally 500 μ s. Derived from: OOBI x 18 750 x 40.

^c 163 840 OOBI is nominally 109,226 μ s. Derived from: OOBI x 4 096 x 40.

^d 153 600 OOBI is nominally 102,4 μ s. Derived from: OOBI x 3 840 x 40.

^e 913 840 OOBI is nominally 609,226 μ s. Derived from: RCDT + SNTT.

^f 29 998 080 OOBI is nominally 19,99872 ms (~ 20 ms, an integer number of training patterns)

^g 29 985 280 OOBI is nominally 19,990166.7 ms (~ 20 ms, an integer number of training patterns)

^h 30 748 080 OOBI is nominally 20,5 ms. Derived from: RCDT + MTT.

Deleted: ^e

Deleted: ^f 913 840 OOBI is nominally 609,226 μ s. Derived from: RCDT + SNTT.
^g30

<Editors Notes:

1. The term and value for TLT was created by the editor and derived by taking the value for MTT and backing it up by the time required for 5 repetition of the TRAIN_DONE pattern. This may or may not be appropriate as MTT is a "gross" timer. This number needs to be agreed to by the working group.

2. The term TWT was created by the editor to make Train-SNW consistent with Final-SNW. The order of other entries and footnotes were re-arrange for the same reason.>

6.7.4.2.3 Speed Negotiation Window Definitions

During each speed negotiation window, a phy shall either:

- a) transmit and receive as defined for the current speed negotiation window; or
- b) transmit D.C. Idle and not attempt to receive.

If a phy transmits as defined for the current speed negotiation window and receives the expected transmission, then the speed negotiation window is valid.

If a phy does not receive the expected transmission from the attached phy, then the speed negotiation window is invalid.

Note x: If a phy transmits D.C. Idle during a speed negotiation window, then the attached phy may not receive the expected transmission and the speed negotiation window is invalid.

- Deleted: both
- Deleted: s
- Deleted: successfully
- Deleted: either
- Deleted: fails to

6.7.4.2.3.1 SNW-1, SNW-2 and Final-SNW Definition

Figure 122 defines the SAS speed negotiation window format for SNW-1, SNW-2 and Final-SNW, including:

- a) speed negotiation window time (SNWT);
- b) rate change delay time (RCDT);
- c) speed negotiation transmit time (SNTT);
- d) speed negotiation lock time (SNLT); and
- e) actual lock time (ALT).

Deleted: Figure 122

- Deleted: <#>speed negotiation window rate;¶
- Formatted: Bullets and Numbering

Figure 122 updated in Rev 7.

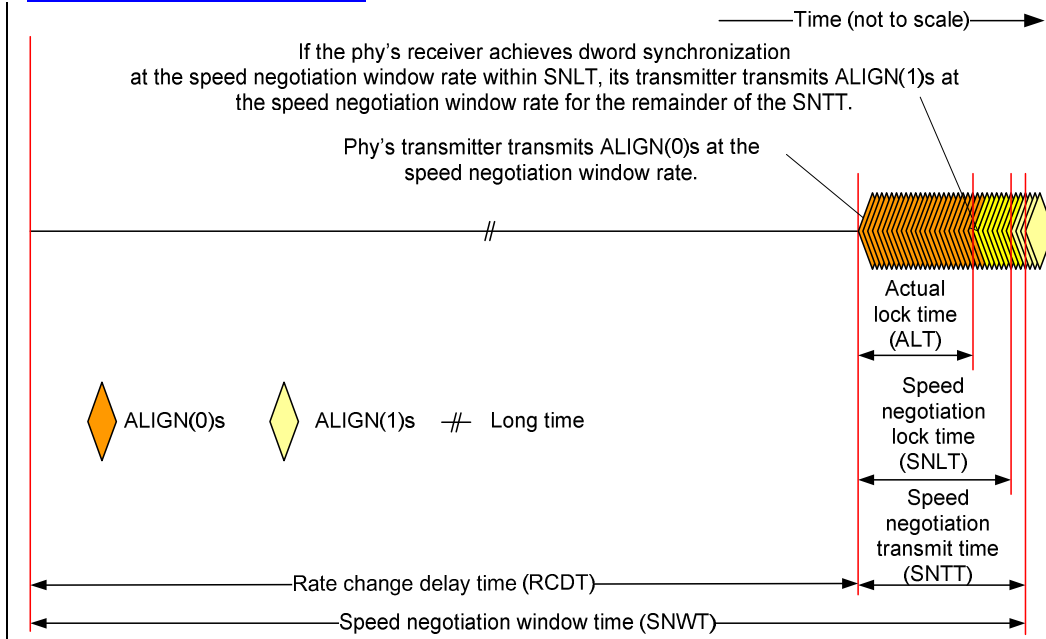

Figure 122 — SAS SNW-1, SNW-2 and Final-SNW

The speed negotiation window shall consist of the following transmission sequence:

- 1) transmission of D.C. idle for an RCDT; and

- 2) if the phy supports the physical link rate or if this is the Final-SNW, transmission of ALIGNs at the physical link rate specified below for the remainder of the entire speed negotiation window time. If the phy does not support the physical link rate, transmission of D.C. idle for the remainder of the entire speed negotiation window time.

The [speed negotiation window](#) rate for SNW-1 shall be 1,5 Gbps.

Deleted: physical link

The [speed negotiation window](#) rate for SNW-2 shall be 3,0 Gbps.

Deleted: physical link

The [speed negotiation window](#) rate for Final-SNW shall be:

Deleted: physical link

- a) 1,5 Gbps if SNW-1 is valid and SNW-2 is invalid; or
- b) 3,0 Gbps if SNW-2 is valid and SNW-3 (see 6.7.4.2.3.2) is invalid.

If the phy supports the speed negotiation window rate, it shall initially transmit ALIGN (0) and it shall attempt to synchronize on an incoming series of dwords at that rate for the SNLT. The received dwords may be ALIGN (0) or ALIGN (1) primitives. If the phy achieves dword synchronization within the SNLT, it shall change from transmitting ALIGN (0) primitives to transmitting ALIGN (1) primitives for the remainder of the SNTT (i.e., the remainder of the speed negotiation window time). The point at which the phy achieves dword synchronization is the Actual lock time (ALT). The change from transmitting ALIGN (0) primitives to transmitting ALIGN (1) primitives shall occur after ALT. If the phy does not achieve dword synchronization within the SNLT, it shall continue transmitting ALIGN (0) primitives for the remainder of the SNTT (i.e., the remainder of the speed negotiation window time).

At the end of the SNTT, if a phy is both transmitting and receiving ALIGN (1) primitives, it shall consider the [speed negotiation window](#) valid.

Deleted: physical link rate

SNW-1, SNW-2 and Final-SNW shall be transmitted with spread spectrum clocking disabled.

6.7.4.2.3.2 SNW-3 Definition

SNW-3 allows the phys to exchange information about their capabilities (e.g., physical link rates supported information, SSC support information, and multiplexing support).

If a phy supports SNW-3, then the phy transmits 32 bits of information describing the capabilities of the phy.

If a phy supports SNW-3, then the phy receives 32 bits of information from the attached phy or D.C. Idle.

If a phy does not support SNW-3, then the phy transmits D.C. Idle.

If a phy does not support SNW-3, then the phy ignores received SNW-3 signaling.

The first bit of information is the start bit and shall be transmitted as a one. Each of the remaining 31 bits of information may be a one or a zero. The transmitter shall transmit 32 BCTs (see Table 80) after an RCDT and then transmit D.C. Idle for the remainder of SNTT.

Each BCT consists of the transmission of a COMWAKE signal (see 6.6.2) or the transmission of D.C. Idle. To transmit a one, a COMWAKE shall be transmitted in the BCT. To transmit a zero, a D.C. Idle shall be transmitted in the BCT.

[Table 81](#) defines the information bits.

Deleted: Table 81

[Figure 123](#) defines the SAS SNW-3, including:

Deleted: Figure 123

- a) speed negotiation window time;
- b) speed negotiation window rate of 1,5 Gbps;
- c) rate change delay time (RCDT); and
- d) speed negotiation transmit time (SNTT).

Figure 123 updated in Rev 7.

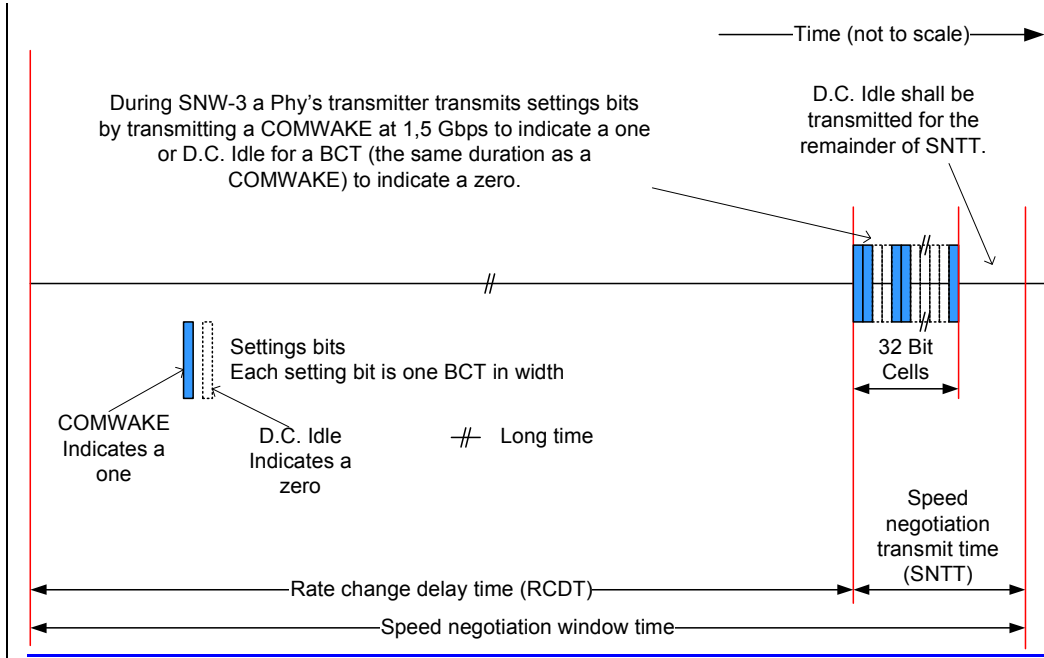

Figure 123 — SAS SNW-3

Table 81 defines the SNW-3 information. For bits defined as reserved, the phy shall transmit zeros (i.e., D.C. Idle) in the outgoing SNW-3 information and shall ignore the bits in the incoming SNW-3 information.

Deleted: Table 81

Table 81 — SNW-3 settings bits

Bit(s)	Description	Changeable ^a
Header		
0 (first bit)	START bit	no
1	TX SSC TYPE bit	no
2 to 7	Reserved [note: 05-381 Multiplexing claims bits 4:7]	no
Supported Settings		
8	G1 WITH SSC SUPPORTED bit	yes
9	G1 WITHOUT SSC SUPPORTED bit	yes
10	G2 WITH SSC SUPPORTED bit	yes
11	G2 WITHOUT SSC SUPPORTED bit	yes
12	G3 WITH SSC SUPPORTED bit	yes
13	G3 WITHOUT SSC SUPPORTED bit	yes
14 to 30	Reserved	no
Trailer		
31 (last bit)	PARITY field	no
^a In the "Changeable" column, phys controlled by a management device server with the SMP PHY CONTROL function (see 10.4.3.18) may set bits labeled "yes" to one in the SNW-3 INFORMATION CHANGEABLE field and shall set bits labeled "no" to zero.		

The START bit shall be set to one. The phy's receiver shall use this bit to establish the timing for the subsequent bits.

A TX SSC TYPE bit set to one indicates that the phy's transmitter uses center-spreading SSC when SSC is enabled. A TX SSC TYPE bit set to zero indicates that the phy's transmitter uses down-spreading SSC when SSC is enabled, or that the phy does not support SSC.

NOTE 1 - The phy receiver may use the TX SSC TYPE bit to optimize its CDR circuitry. This bit indicates the type of SSC used when attached to a SAS phy or an expander phy; if a phy supports center-spreading when attached to a SAS phy or an expander phy and down-spreading when attached to a SATA phy, it sets the TX SSC TYPE bit to one.

The G<GENERATION NUMBER> WITH SSC SUPPORTED bits and G<GENERATION NUMBER> WITHOUT SSC SUPPORTED bits indicate the physical link rates and SSC options the phy is attempting to negotiate.

A G1 WITHOUT SSC SUPPORTED bit set to one indicates that the phy supports G1 without SSC. A G1 WITHOUT SSC SUPPORTED bit set to zero indicates that the phy does not support G1 without SSC.

A G1 WITH SSC SUPPORTED bit set to one indicates that the phy supports G1 (i.e., 1,5 Gbps) with SSC. A G1 WITH SSC SUPPORTED bit set to zero indicates that the phy does not support G1 with SSC.

A G2 WITHOUT SSC SUPPORTED bit set to one indicates that the phy supports G2 without SSC. A G2 WITHOUT SSC SUPPORTED bit set to zero indicates that the phy does not support G2 without SSC.

A G2 WITH SSC SUPPORTED bit set to one indicates that the phy supports G2 (i.e., 3 Gbps) with SSC. A G2 WITH SSC SUPPORTED bit set to zero indicates that the phy does not support G2 with SSC.

A G3 WITHOUT SSC SUPPORTED bit set to one indicates that the phy supports G3 without SSC. A G3 WITHOUT SSC SUPPORTED bit set to zero indicates that the phy does not support G3 without SSC.

A G3 WITH SSC SUPPORTED bit set to one indicates that the phy supports G3 (i.e., 6 Gbps) with SSC. A G3 WITH SSC SUPPORTED bit set to zero indicates that the phy does not support G3 with SSC.

The PARITY bit provides for error detection of all the SNW-3 information bits. The PARITY bit shall be set to one or zero such that the total number of SNW-3 information bits that are set to one is even, including the START bit and the PARITY bit. If the PARITY bit received is incorrect, the phy shall consider it a phy reset problem. Phy reset problems may be counted and reported in the PHY RESET PROBLEM COUNT field in the SMP REPORT PHY ERROR LOG page (see 10.4.3.8) and the Protocol-Specific Port log page (see 10.2.8.1).

Table 3 lists some example SNW-3 information values.

Table 82 lists some example SNW-3 settings bits.

Deleted: Table 82

Table 82 — Example SNW-3 settings bits

Code ^a	Description
80A8000h	Down-spreading SSC G1, G2, and G3 with SSC supported
80FC0001h	Down-spreading SSC G1, G2, and G3 with and without SSC supported
C0540001h	Center-spreading SSC G1, G2, and G3 without SSC supported
C0FC0000h	Center-spreading SSC G1, G2, and G3 with and without SSC supported
^a Expressed as a 32-bit value with bit 0 (i.e., the START bit) as the MSB and bit 31 as the LSB (i.e., the PARITY bit).	

If SNW-3 is not supported, then the phy shall transmit D.C. Idle during SNW-3.

Deleted: to indicate the SNW-3 is invalid

If SNW-3 is supported and a phy receives at least one COMWAKE, then SNW-3 is valid.

If SNW-3 is valid and the parity of the received BCTs is incorrect, then a phy reset problem has occurred. Phy reset problems may be counted and reported in the PHY RESET PROBLEM COUNT field in the SMP REPORT PHY ERROR LOG page (see 10.4.3.8) and the Protocol-Specific Port log page (see 10.2.8.1).

The phy shall negotiate to the highest commonly supported settings based on the outgoing and incoming SNW-3 information supported settings bits.

Deleted: For bits defined as reserved, the phy shall transmit zeros in the outgoing SNW-3 information and shall ignore the bits in the incoming SNW-3 information.

Table 83 defines the priority of the SNW-3 supported settings.

Deleted: Table 83

Table 83 — Negotiation priority of SNW-3 information supported settings

Priority	Supported Setting
Highest	G3 with SSC
...	G3 without SSC
...	G2 with SSC
...	G2 without SSC
...	G1 with SSC
Lowest	G1 without SSC

The transmitter shall use SAS signal output levels during the SAS speed negotiation sequence as described in 5.3.6.5.

Deleted: ing

6.7.4.2.3.3 Train-SNW Definition

Figure 124 defines the Train-SNW, including:

- a) maximum Train-SNW window time (MTT);
- b) rate change delay time (RCDT);
- c) maximum train time (MTT);
- d) train lock time (TLT);
- e) actual training time (ATT); and

Deleted: Figure 124

Deleted: final speed negotiation window time

Formatted: Bullets and Numbering

Deleted: <#>maximum training time (MTT).¶
-----Page Break-----

Figure 124 updated in Rev 7.

The phy shall transition to transmitting Link Layer dwords after transmitting a minimum of 4 TRAIN_DONE patterns and receiving one TRAIN_DONE. This represents the successful end of the Train-SNW and the beginning of normal link layer operation. If a phy has not transmitted at least four TRAIN_DONE patterns, and receive at least one TRAIN_DONE within MTT, then the Train-SNW is unsuccessful.

Actual training time (ATT) starts after RCDT and ends when receiver training is completed and dword synchronization is obtained. The phy transmits the TRAIN pattern starting after RCDT. A minimum of one TRAIN pattern shall be transmitted. When ATT ends, the phy transitions to transmitting TRAIN_DONE patterns. If ATT does not end before TLT, then the phy shall not transition to transmitting the TRAIN_DONE pattern.

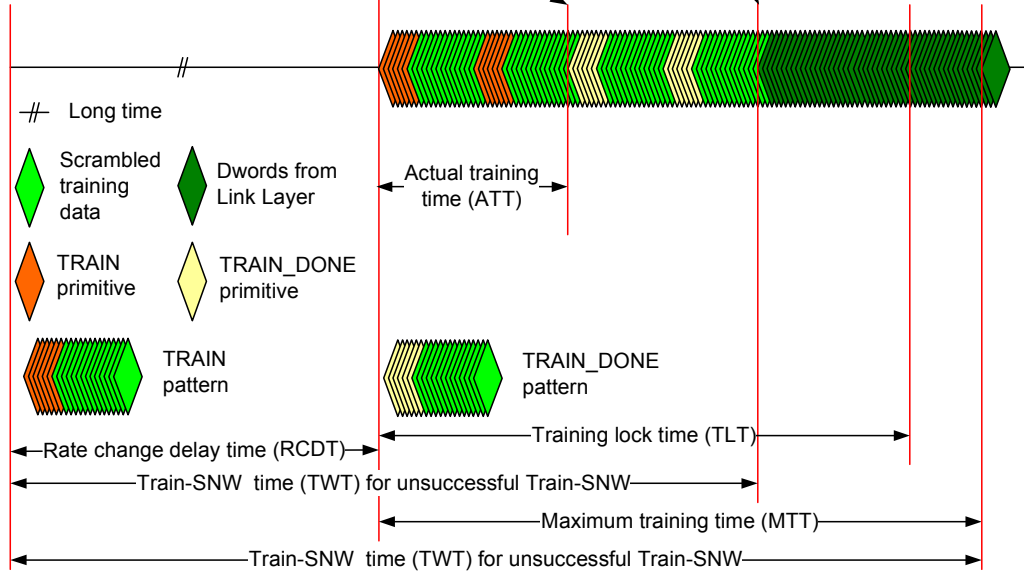

Figure 124 — SAS Train-SNW

The Train-SNW utilizes TRAIN and TRAIN_DONE as defined in 7.2. TRAIN and TRAIN_DONE are used within training patterns.

Deleted: primitive sequences

Deleted: x.x.x.x

Deleted: These primitive sequences

There are two training patterns, the TRAIN pattern and the TRAIN_DONE pattern. Each training pattern consists of:

- 1) either a TRAIN if the pattern is a TRAIN pattern, or a TRAIN_DONE if the pattern is a TRAIN_DONE pattern; and
- 2) 58 dwords of value 0000_0000h that are transmitted scrambled and 8b10b encoded.

Deleted: primitive sequence

Deleted: primitive sequence

The scrambler is as defined for the link layer and shall be initialized at the end of RCDT within the Train-SNW. The scrambler shall not be re-initialized for the remainder of the Train-SNW.

Deleted: window

The transmitter shall start transmitting TRAIN patterns at the end of RCDT portion of the Train-SNW. The number of TRAIN patterns transmitted is determined by the time required for the phy's receiver to complete training. At least one TRAIN pattern shall be transmitted.

Deleted: beginning of the MTT

Deleted: window

If the phy's receiver is trained and acquires dword synchronization before training lock time (TLT), then the phy shall stop transmitting TRAIN patterns and start transmitting TRAIN_DONE patterns. A minimum of four TRAIN_DONE patterns shall be transmitted.

Deleted: After

Deleted: the

Deleted: with

If the phy transmits four or more TRAIN_DONE patterns and receives a minimum of one TRAIN_DONE before the maximum training time (MTT), then the phy shall stop transmitting TRAIN_DONE patterns, shall start transmitting dwords from the link layer and the Train-SNW is valid.

Deleted: primitive sequence

Deleted: is reached

Deleted: and

Deleted: . In this case

Deleted: successful

6.7.4.2.4 SAS speed negotiation sequence

The SAS speed negotiation sequence consists of a set of speed negotiation windows (see 6.7.4.2.3) for each physical link rate as follows:

Deleted: If either phy does not transmitted a minimum of four TRAIN_DONE patterns before the maximum training time (MTT) is reached, then the SNW-3 is unsuccessful. ¶

- 1) SNW-1 (i.e., to negotiate 1,5 Gbps without training capabilities);
- 2) SNW-2 (i.e., to negotiate 3 Gbps without training capabilities); and
- 3) one of the following sequences:
 - a) a Final-SNW negotiating 1,5 Gbps if SNW-1 is valid and SNW-2 is invalid; or
 - b) an SNW-3 followed by one of the following:
 - A) a Final-SNW negotiating 3,0 Gbps if SNW-2 is valid and SNW-3 is invalid; or
 - B) one or more Train-SNWs if SNW-3 is valid, the parity of the received settings bits is correct and there is one or more commonly supported settings.

Deleted: was

Deleted: was

Deleted: was

Deleted: was

Deleted: ing

If SNW-1, SNW-2, and SNW-3 are all invalid, then a phy reset problem has occurred. Phy reset problems may be counted and reported in the PHY RESET PROBLEM COUNT field in the SMP REPORT PHY ERROR LOG page (see 10.4.3.8) and the Protocol-Specific Port log page (see 10.2.8.1).

Deleted: was

Deleted: were

If a Final-SNW is performed and is invalid, then a phy reset problem has occurred.

Deleted: window

If a phy participates in a valid SNW-3, then the phy shall participate in a Train-SNW utilizing the highest commonly supported settings based on the outgoing and incoming SNW-3 settings bits (see Table 80).

Deleted: unsuccessful

Deleted: participated

Deleted: n

If there is no commonly supported settings exchanged during SNW-3, then a phy reset problem occurred. Phy reset problems may be counted and reported in the PHY RESET PROBLEM COUNT field in the SMP REPORT PHY ERROR LOG page (see 10.4.3.8) and the Protocol-Specific Port log page (see 10.2.8.1).

Deleted: window by transmitting its supported settings and successfully received the supported settings transmitted by the other phy

Deleted: ing

If a Train-SNW is invalid and there are additional, untried, commonly supported settings exchanged during SNW-3, then a new Train-SNW shall be performed at the next highest, untried, commonly supported capability. If a Train-SNW is invalid and there are no additional, untried, commonly supported settings exchanged during SNW-3, then a phy reset problem occurred.

Deleted: ing

Deleted: invalid and is unsuccessful

Deleted: (see Table 80)

Deleted: ing

Deleted: ing

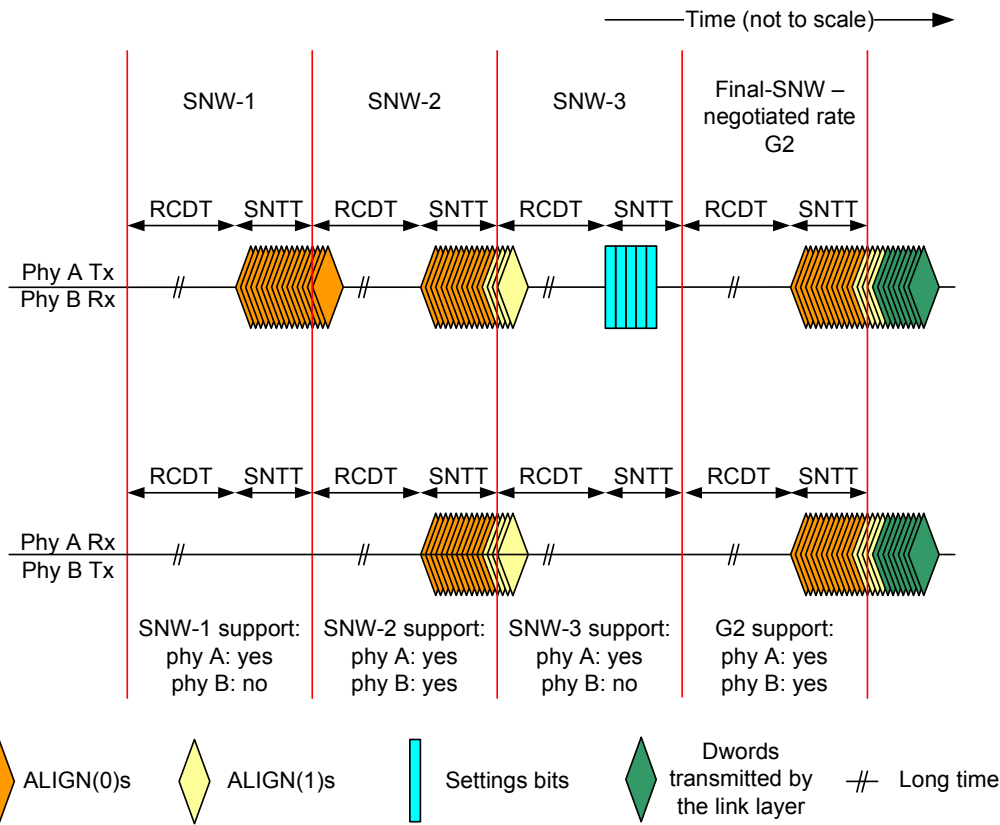

Figure 125 is an example of speed negotiation between a phy A that supports G1 through G3 and a phy B that only supports G2. Both phys participate in:

- 1) the SNW-1 (supported by phy A but not by phy B);
- 2) the SNW-2 (supported by both phys);
- 3) the SNW-3 (supported by phy A but not by phy B); and
- 4) the Final-SNW at G2.

Deleted: Figure 125

Deleted: ¶

Deleted: 3,0 Gbps

Figure 125 updated in Rev 7.

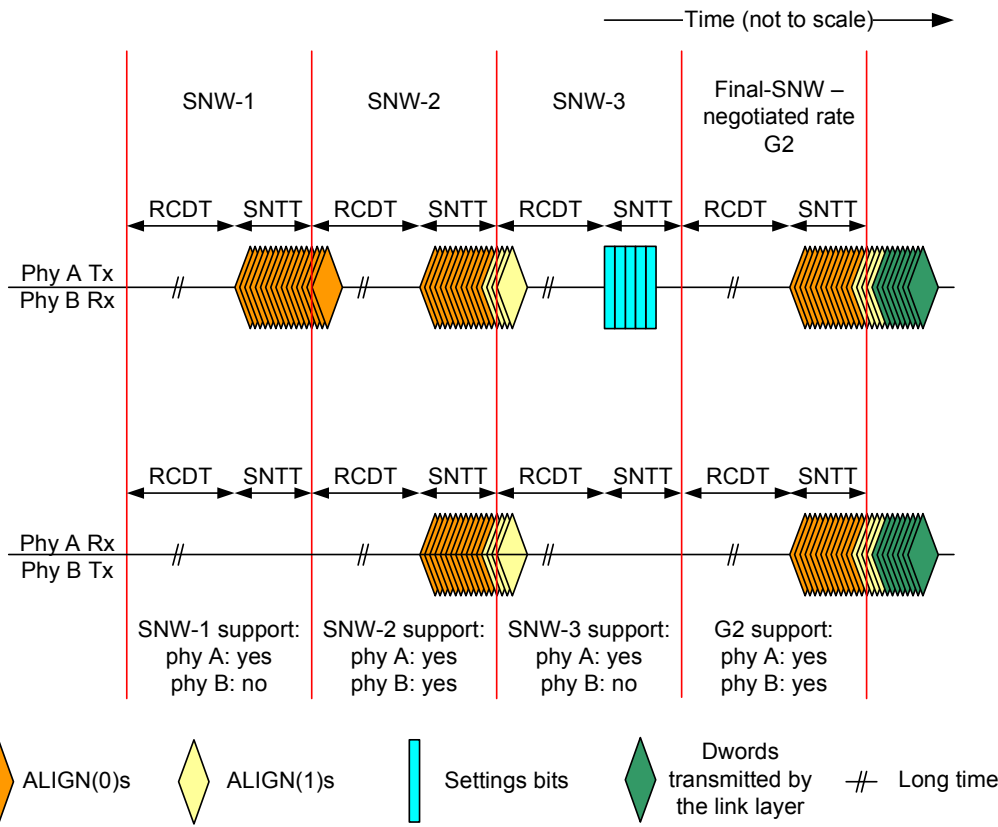

Figure 125 — SAS speed negotiation sequence (phy A: G1, G2, G3, phy B: G2 only)

Phy A and phy B detect an invalid SNW-1, a valid SNW-2, followed by an invalid SNW-3, and correctly proceeds to a Final-SNW at G2.

If the phy does not achieve dword synchronization during the Final-SNW, then the SAS speed negotiation sequence fails. This is a phy reset problem and may be counted and reported in the PHY RESET PROBLEM COUNT field in the SMP REPORT PHY ERROR LOG page (see 10.4.3.6) and the Protocol-Specific Port log page (see 10.2.8.1).

Figure 126 shows a speed negotiation sequence where phy B does not achieve dword synchronization during the Final-SNW. If this occurs, the handshake is not complete and the phy reset sequence is retried.

Deleted: ¶

Deleted: window

Deleted: window

Deleted: window

Deleted: This is defined as

Deleted: Figure 126

Figure 126 updated in Rev 7.

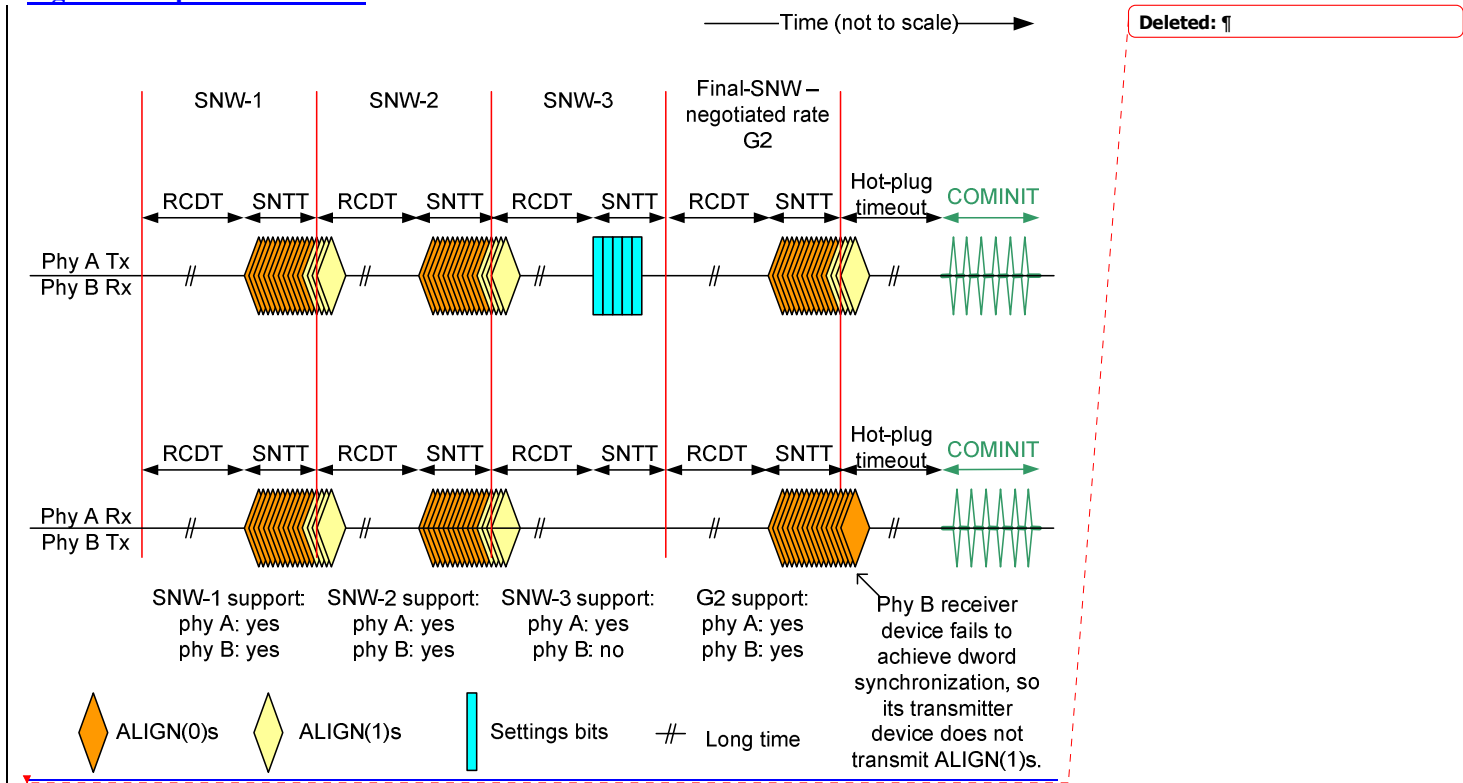

Figure 126 — SAS Final-SNW phy reset problem

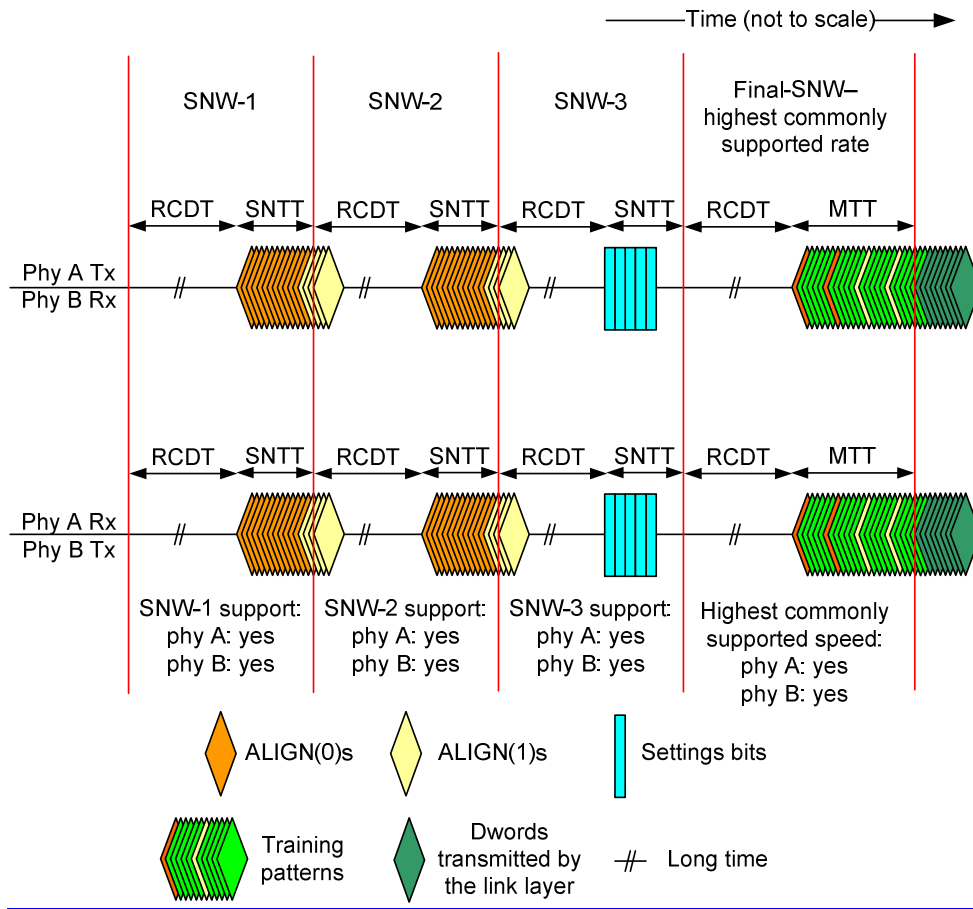

Figure 127 shows speed negotiation between a phy A and a phy B that both support G1 and G2 rates without requiring training and also support additional capabilities. Both phys participate in:

- 1) the SNW-1 (supported by both phys);
- 2) the SNW-2 (supported by both phys);
- 3) the SNW-3 (supported by both); and
- 4) the Train-SNW (supported by both phys).

Deleted: Figure 127

Deleted: run

Deleted: ,

Deleted: ,

Deleted: and

Deleted: ,

Deleted: phys where the settings bits are exchanged and the highest common rate supported by both phys is negotiated

Deleted: ing

Deleted: ,

Deleted: where training is done

Figure 127 updated in Rev 7.

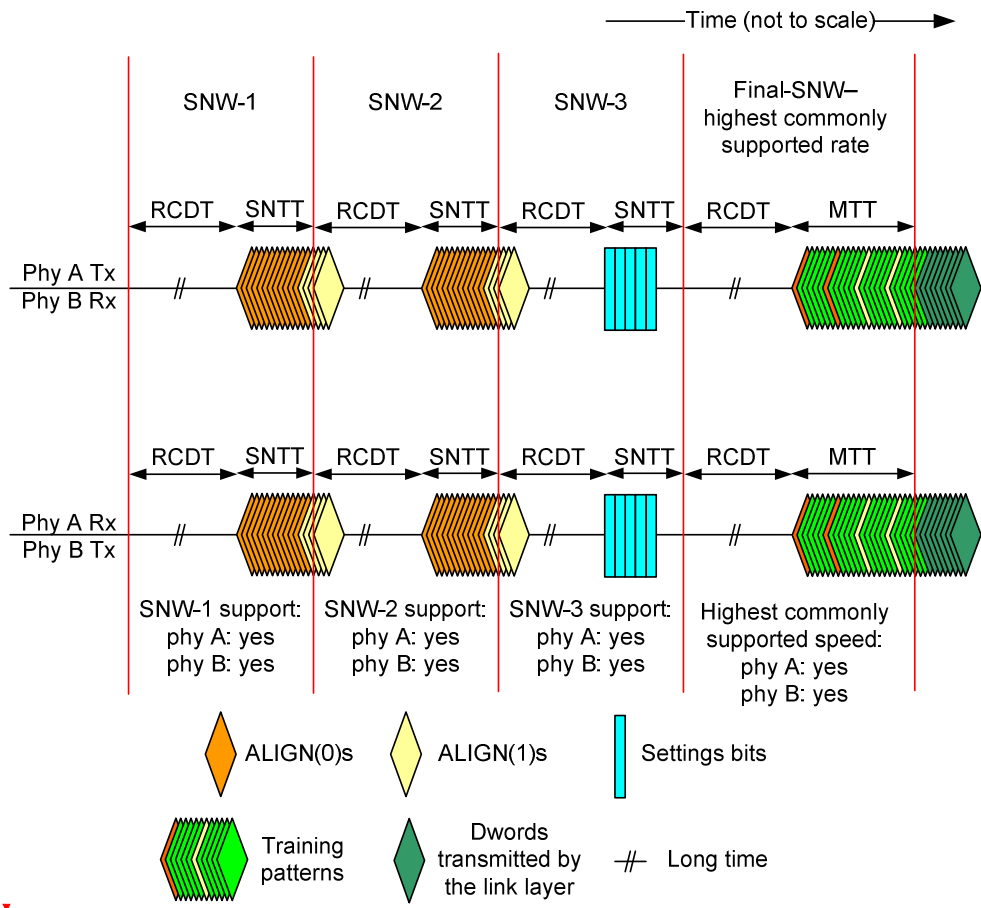

Deleted: ¶

Figure 127 — SAS speed negotiation sequence (phy A: G1, G2, G3 or higher, phy B: G1, G2, G3 or higher)

A phy reset problem may be encountered if:

the phys do not exchange the settings bits properly (e.g., due to a parity error) in SNW-3 (see

Deleted: window

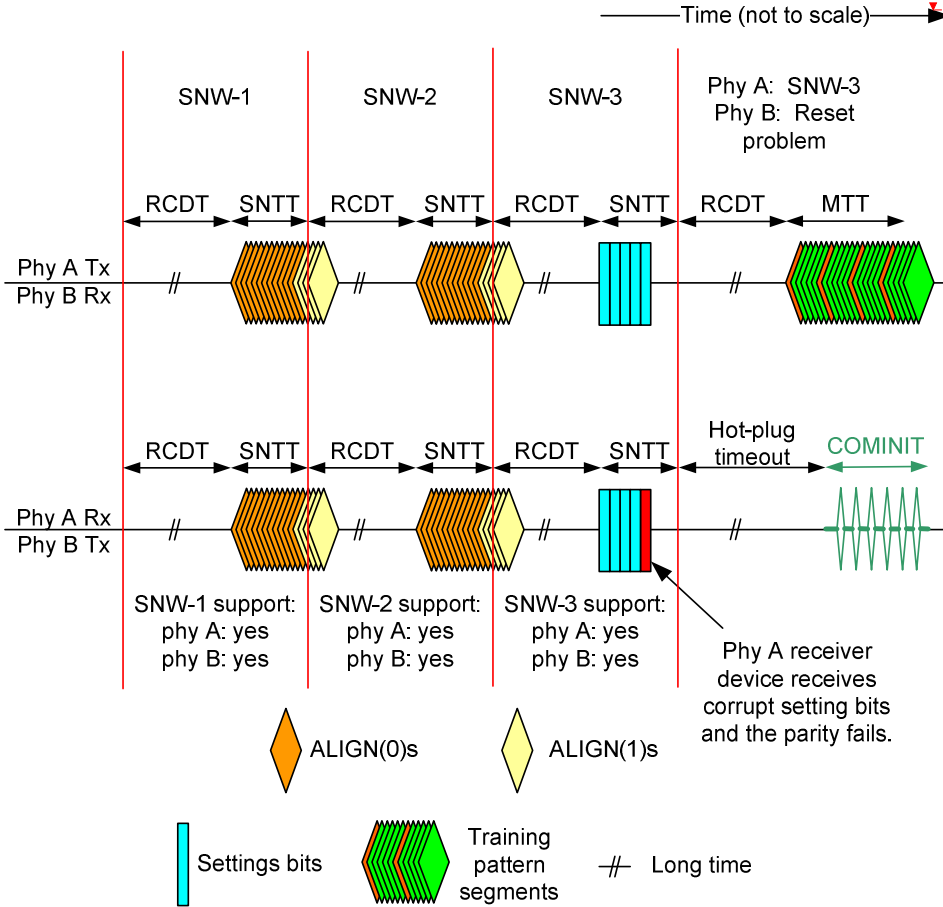

- 1) [Figure 128](#); or
- 2) either phy does not complete training within the MTT interval of several training windows exhausting all common settings exchanged in SNW-3 (see

Deleted: Figure 128

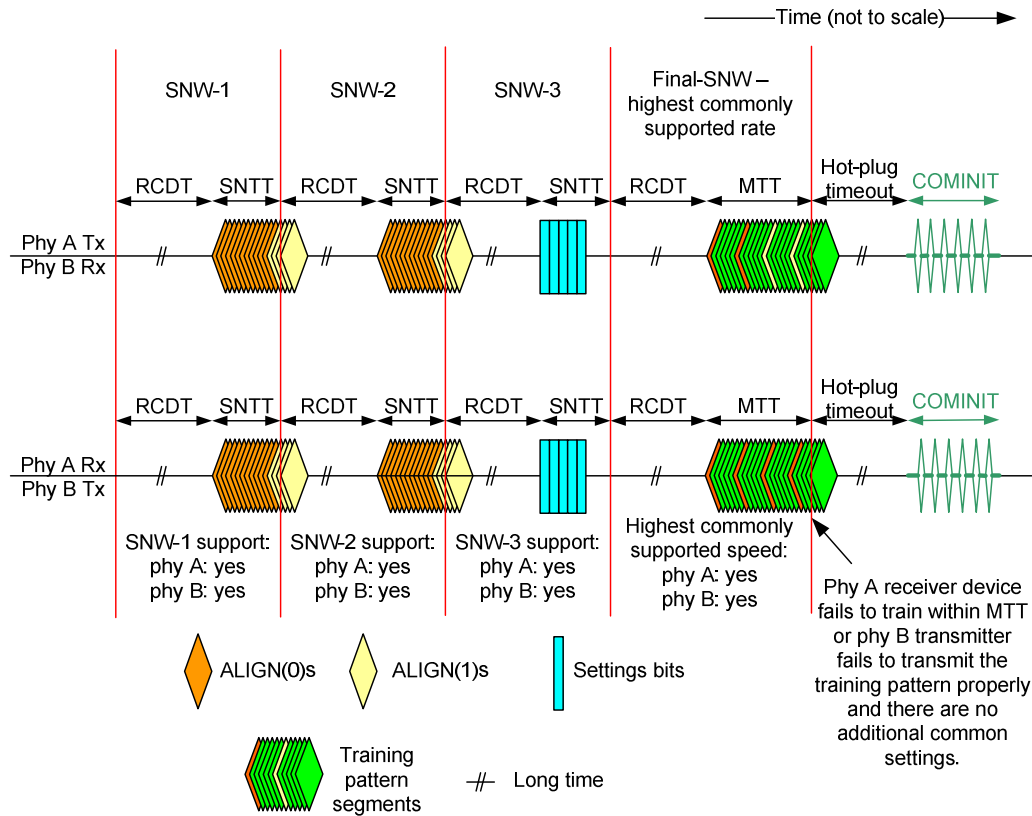

Figure 129)..

Deleted: Figure 129

Figure 128 updated in Rev 7.

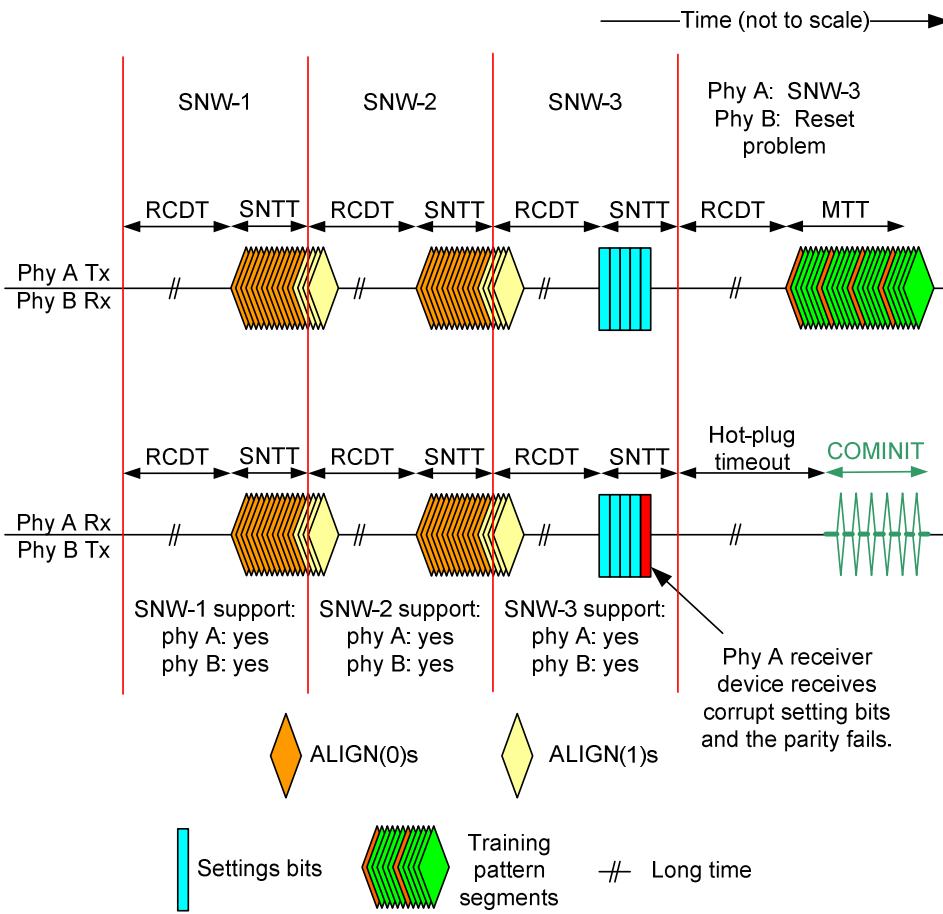

Figure 128 — SAS speed negotiation sequence - SNW-3 (maximum SNW) phy reset problem

These phy reset problems may be counted and reported in the PHY RESET PROBLEM COUNT field in the SMP REPORT PHY ERROR LOG page (see 10.4.3.6) and the Protocol-Specific Port log page (see 10.2.8.1).

Figure 129 updated in Rev 7.

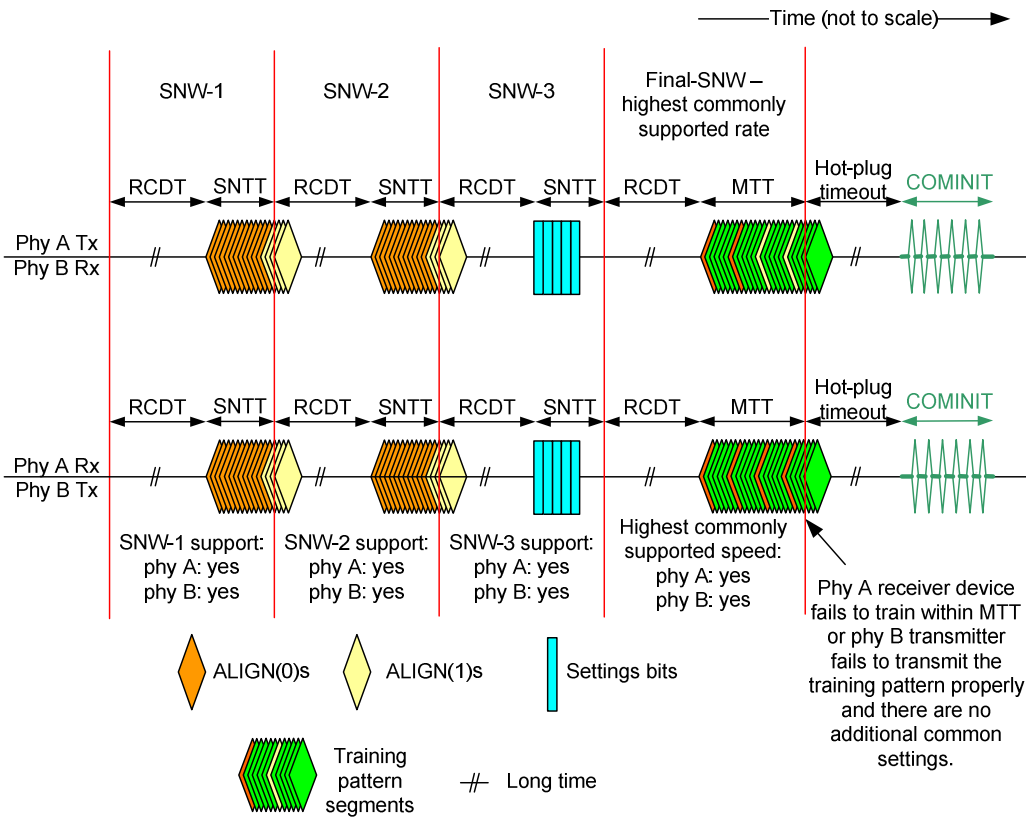

Figure 129 — SAS speed negotiation sequence - training (Train-SNW) phy reset problem

Deleted: SNW-Final

If settings bits are exchanged that contain more than one common setting and the Train-SNW using the highest common capability is invalid, a second Train-SNW is performed using the next highest common setting, as shown in Figure NEW-1.

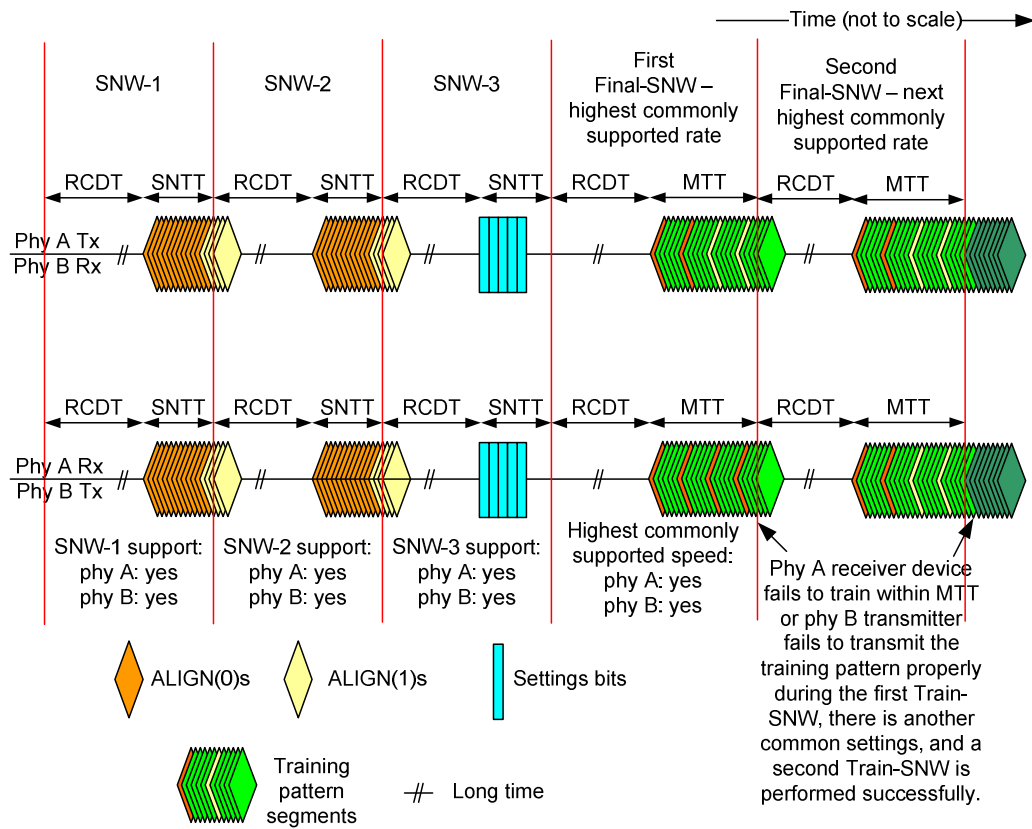

Figure NEW1 – SAS speed negotiation sequence – First Train-SNW is invalid, Second Train-SNW valid

For more examples of speed negotiations between phys that support various speeds, see Annex C.

<Editor’s Note: We should review what is in Annex C and see if more examples are needed.>

Clause 6.8

Suggested changes to clause 6.8, 6.8.1, and 6.8.2: All changes are additions of blue text.

6.8 SP (phy layer) state machine

6.8.1 SP state machine overview

The SP state machine controls the phy reset sequence. This state machine consists of three sets of states:

- a) OOB sequence (OOB) states;
- b) SAS speed negotiation (SAS) states; and
- c) SATA host emulation (SATA) states.

This state machine consists of the following states:

- a) SP0:OOB_COMINIT (see 6.8.3.2)(initial state);
- b) SP1:OOB_AwaitCOMX (see 6.8.3.3);

- c) SP2:OOB_NoCOMSASTimeout (see 6.8.3.4);
- d) SP3:OOB_AwaitCOMINIT_Sent (see 6.8.3.4);
- e) SP4:OOB_COMSAS (see 6.8.3.4);
- f) SP5:OOB_AwaitCOMSAS_Sent (see 6.8.3.4);
- g) SP6:OOB_AwaitNoCOMSAS (see 6.8.3.4);
- h) SP7:OOB_AwaitCOMSAS (see 6.8.3.4);
- i) SP8:SAS_Start (see 6.8.3.4);
- j) SP9:SAS_WindowNotSupported (see 6.8.3.4);
- k) SP10:SAS_AwaitALIGN (see 6.8.3.4);
- l) SP11:SAS_AwaitALIGN1 (see 6.8.3.4);
- m) SP12:SAS_AwaitSNW (see 6.8.3.4);
- n) SP13:SAS_Pass (see 6.8.3.4);
- o) SP14 SAS_Fail (see 6.8.3.4);
- p) SP15:SAS_PHY_Ready (see 6.8.3.4);
- q) SP16:SATA_COMWAKE (see 6.8.3.4);
- r) SP17:SATA_AwaitCOMWAKE (see 6.8.3.4);
- s) SP18:SATA_AwaitNoCOMWAKE (see 6.8.3.4);
- t) SP19:SATA_AwaitALIGN (see 6.8.3.4);
- u) SP20:SATA_AdjustSpeed (see 6.8.3.4);
- v) SP21:SATA_Transmit_ALIGN (see 6.8.3.4);
- w) SP22:SATA_PHY_Ready (see 6.8.3.4);
- x) SP23:SATA_PM_Partial (see 6.8.3.4);
- y) SP24:SATA_PM_Slumber (see 6.8.3.4);
- z) SP25:SATA_PortSel (see 6.8.3.4); and
- aa) SP26:SATA_SpinupHold (see 6.8.3.4).
- bb) ~~SP27:SAS_Settings (see 6.8.3.4);~~
- cc) ~~SP28:SAS_FinalSNW (see 6.8.3.4);~~
- dd) ~~SP29:SAS_Training (see 6.8.3.4); and~~
- ee) ~~SP30:SAS_TrainingDone (see 6.8.3.4).~~

Deleted: RateNotSupported

Deleted: SAS2

Deleted: SAS2

Deleted: SAS2

Deleted: SAS2

The SP state machine shall start in the SP0:OOB_COMINIT state after:

- a) a power on;
- b) a hard reset;
- c) receiving a Management Reset request from the management layer (e.g., from the SMP PHY CONTROL function requesting a phy operation of LINK RESET or HARD RESET in an expander device); or
- d) receiving a Disable Phy request from the management layer (e.g., from the SMP PHY CONTROL function requesting a phy operation of DISABLE in an expander device).

The SP state machine shall maintain a MgmtReset state machine variable to determine whether a Management Reset request has been received. Any SP state that receives a Management Reset request shall set the MgmtReset state machine variable to one before making a transition to the SP0:OOB_COMINIT state (see 6.8.3.2). Any SP state that receives a power on, or a hard reset shall set the MgmtReset state machine variable to zero before making a transition to the SP0:OOB_COMINIT state.

If the phy supports SATA port selectors, the SP state machine shall maintain a COMWAKE_Received state machine variable to indicate whether a COMWAKE detected message was received in the SP0:OOB_COMINIT state or the SP1:OOB_AwaitCOMX state since the last time the SP0:OOB_COMINIT state was entered, and the SP state machine shall transition to the SP25:SATA_PortSel state whenever it receives a Transmit SATA Port Selection Signal request.

The SP state machine sends the following messages to the SP_DWS state machine (see 6.9):

- a) Start DWS; and
- b) Stop DWS.

The SP state machine receives the following messages from the SP_DWS state machine:

- a) DWS Lost; and
- b) DWS Reset.

The SP state machine shall maintain the timers listed in [Table 84](#).

Deleted: Table 84

Table 84 — SP state machine timers

Timer	Initial value
COMSAS Detect Timeout timer	COMSAS detect timeout (see table 66 in 6.6.1)
Await ALIGN Timeout timer	Await ALIGN timeout (see table 73 in 6.7.2.2)
Hot-Plug Timeout timer	Hot plug timeout (see table 72 in 6.7.1)
RCDT timer	RCDT (see table 77 in 6.7.4.2)
SNLT timer	SNLT (see table 77 in 6.7.4.2)
SNTT timer	SNTT (see table 77 in 6.7.4.2)
TLT timer	TLT (see table 77 in 6.7.4.2)
MTT timer	MTT (see table 77 in 6.7.4.2)

6.8.2 SP transmitter and receiver

The SP transmitter transmits OOB signals and dwords on the physical link based on messages from the SP state machine (see 6.8).

The SP transmitter receives the following messages from the SP state machine:

- a) Transmit COMINIT;
- b) Transmit COMSAS;
- c) Transmit COMWAKE;
- d) Transmit SATA Port Selection Signal;
- e) Transmit D10.2;
- f) Set Rate (Physical Link Rate, SSC modulation type);
- g) Transmit ALIGN with an argument indicating the specific type (e.g., Transmit ALIGN (0));
- h) [Transmit Settings Bits](#);
- i) [Transmit TRAIN pattern](#);
- j) [Transmit TRAIN_DONE pattern](#); and

When not otherwise instructed, the SP transmitter transmits D.C. idle.

The SP transmitter shall complete any physical link rate change requested with the Set Rate message within RCDT (see table 77 in 6.7.4.2).

The SP transmitter sends the following messages to the SP state machine:

- a) COMINIT Transmitted;
- b) COMSAS Transmitted;
- c) COMWAKE Transmitted;
- d) SATA Port Selection Signal Transmitted; and
- e) [Settings Bits Transmitted](#).

The SP receiver receives OOB signals and dwords from the physical link and sends messages to the SP state machine indicating what it has received.

The SP receiver receives the following messages from the SP state machine:

- a) Set Rate (Physical Link Rate, SSC modulation type);
- b) Start Training; and
- c) Abort Training.

Deleted: The SP state machine sends the following messages to the SP receiver:¶

Formatted: Bullets and Numbering

The SP receiver sends the following messages to the SP state machine:

- a) COMINIT Detected;
- b) COMSAS Detected;
- c) COMSAS Completed;
- d) COMWAKE Detected;
- e) COMWAKE Completed;
- f) ALIGN Received with an argument indicating the specific type (e.g., ALIGN Received (0));
- g) Dword Received;
- h) Settings Bits Completed with an argument indicating whether the parity of the settings bits was valid or invalid (e.g., Settings Bits Completed (Valid));
- i) Training Completed; and
- j) TRAIN_DONE Received.

The ALIGN Received and Dword Received messages are only sent when the SP_DWS state machine has achieved dword synchronization.

For SATA speed negotiation, the ALIGN Received (0) message includes an argument containing the physical link rate at which the ALIGN (0) primitives were detected. For SAS speed negotiation, only ALIGNs at the physical link rate specified by the last Set Rate message received by the SP transmitter cause ALIGN Received messages.

No changes to clause 6.8.3.

Suggested changes to clause 6.8.4: All changes are additions of blue text.

6.8.4 SAS speed negotiation states

6.8.4.1 SAS speed negotiation states overview

Figure 131 shows the SAS speed negotiation states, in which the phy has detected that it is attached to a SAS phy or expander phy rather than a SATA phy, and performs the SAS speed negotiation sequence. These states are indicated by state names with a prefix of SAS.

Deleted: Figure 131

Changes to Figure 132 are in RED and Underlined in the figure. The associated transition arrows are also added in RED.

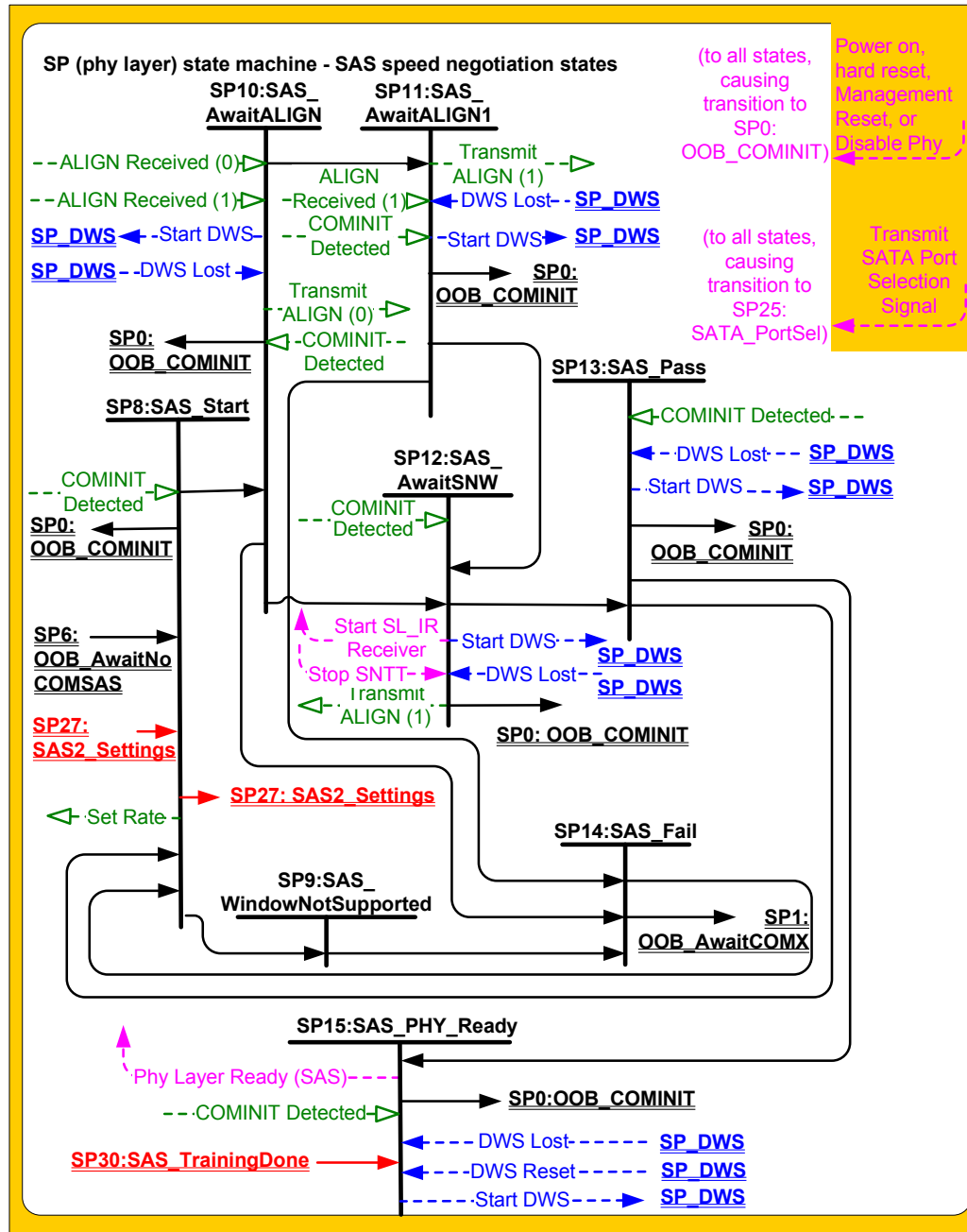
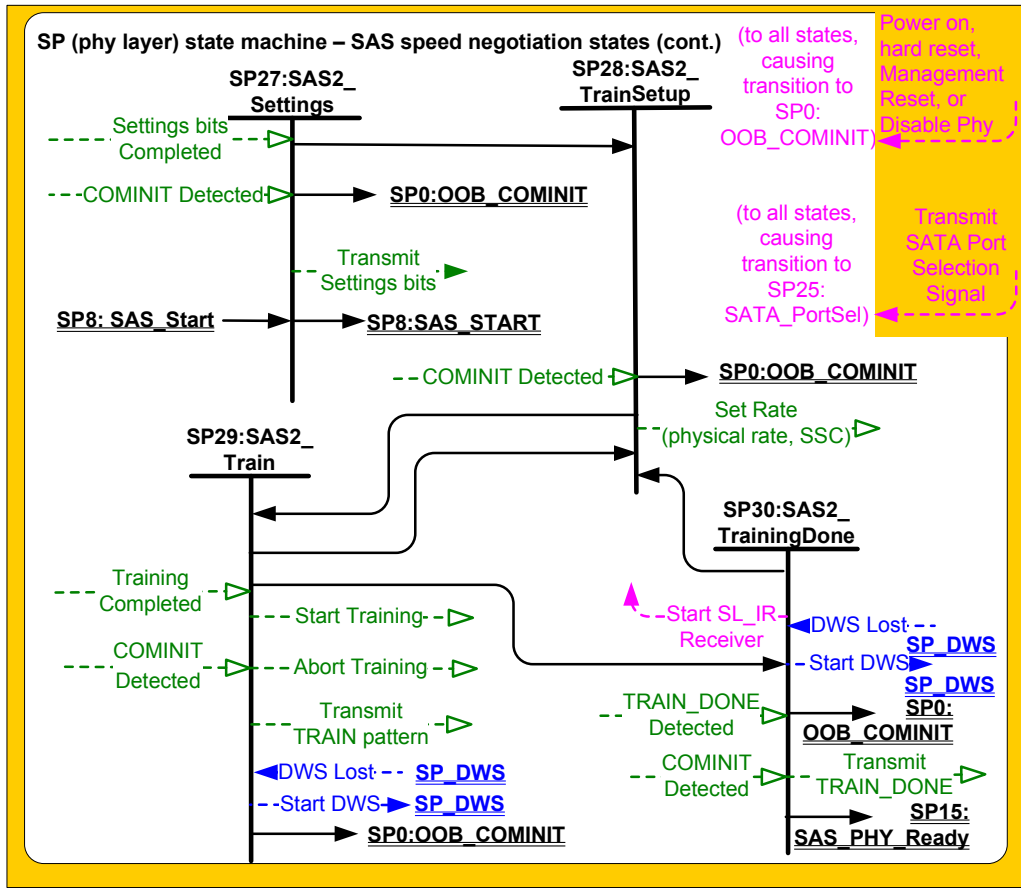

Figure 131— SP (phy layer) state machine - SAS speed negotiation states

Figure 132 is a completely new figure.



Formatted: Font color: Blue, English (U.S.)

Figure 132 shows the rest of the SAS speed negotiation states related to SNW-3 and the Final-SNW speed negotiation windows.

Deleted: Figure 132

Deleted: -Final

Deleted: These states are indicated by state names with a prefix of SAS2.¶

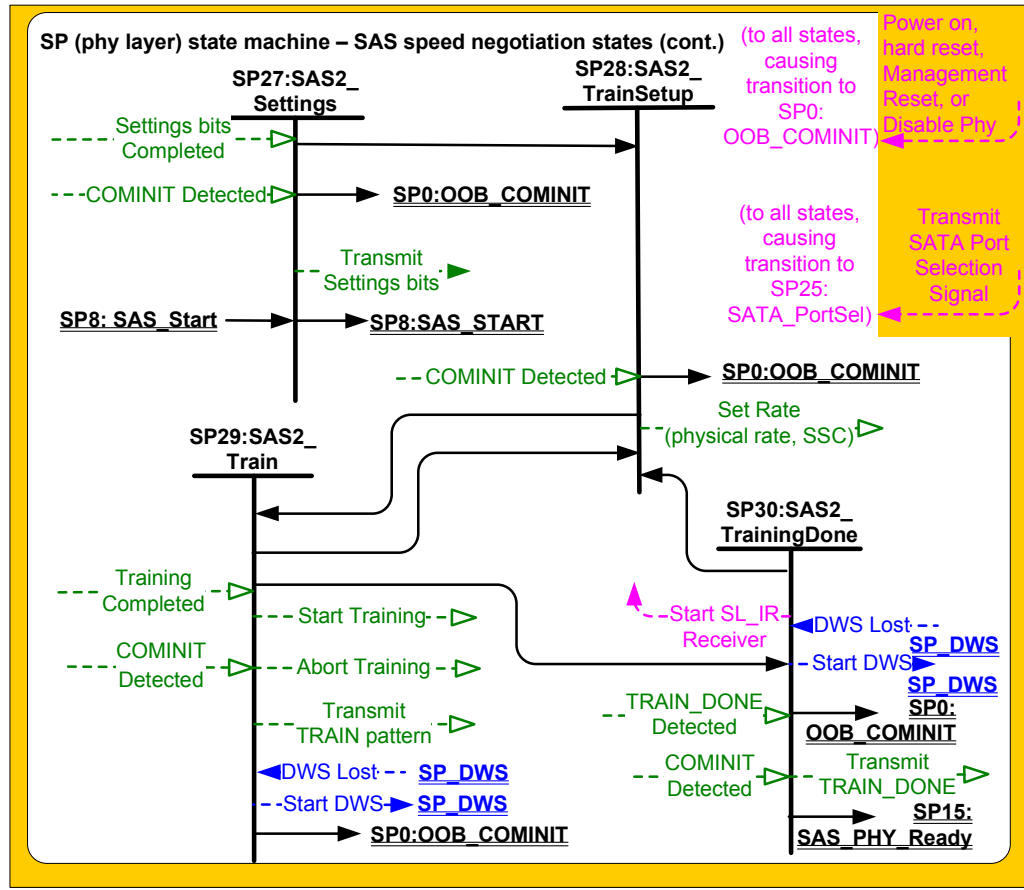

Figure 132 — SP (phy layer) state machine - SAS speed negotiation states (continued)

6.8.4.2 SP8:SAS_Start state

6.8.4.2.1 State description

This is the initial state for the SAS speed negotiation sequence.

Upon entry into this state, this state shall:

- a) initialize and start the RCDT timer;
- b) send a Set Rate message to the SP transmitter and SP receiver with:
 - A) the Physical Link Rate argument set to 1,5 Gbps and SSC modulation type argument set to None, if the transition into this state was from the SP6:OOB_AwaitNoCOMSAS state (i.e., this is SNW-1); or
 - B) the Physical Link Rate argument set to 3,0 Gbps and SSC modulation type argument set to None, if the transition into this state was from the SP13:SAS_Pass or SP14:SAS_Fail state and the previous speed negotiation window was SNW-1 (i.e., this is SNW-2);
 - C) the Physical Link Rate argument set to 1,5 Gbps and SSC modulation type argument set to None, if the transition into this state was from SP14:SAS_Fail state, the previous speed negotiation window was SNW-2 and SNW-1 was valid (i.e., this is Final-SNW at G1);
 - D) the Physical Link Rate argument set to 3,0 GBps and SSC modulation type argument set to None, if the transiton into this state was from SPxx:SAS_Settings and SNW-2 was valid (i.e., this is Final-SNW at G2); or

Deleted: the argument set to

Deleted: if

Deleted: the first speed negotiation window

Formatted: Bullets and Numbering

E) the Physical Link Rate argument set to 1,5 Gbps, if the transition into this state was from the SP13:SAS_Pass or SP14:SAS_Fail state and the previous speed negotiation window was SNW-2 (i.e., if this is SNW-3).

Deleted: 1,5 Gbps, if the SAS Speed Negotiaion Window is SNW-3; or

Note x: In case E above, the setting of SSC modulation type is implementation dependent.

During this state D.C. idle shall be transmitted.

Deleted: <#>the value of the SAS Speed Negotiation Window Rate argument for G1 and G2 in SNW-1 and SNW-2.¶

6.8.4.2.2 Transition SP8:SAS_Start to SP0:OOB_COMINIT

This transition shall occur after receiving a COMINIT Detected message.

6.8.4.2.3 Transition SP8:SAS_Start to SP9:SAS_WindowNotSupported

Deleted: RateNotSupported

This transition shall occur after the RCDT timer expires if the current speed negotiation window is not supported.

Deleted: rate

6.8.4.2.4 Transition SP8:SAS_Start to SP10:SAS_AwaitALIGN

This transition shall occur after the RCDT timer expires if the current speed negotiation window is not SNW-3 and the window is supported.

Deleted: its

Deleted: rate

6.8.4.2.5 Transition SP8:SAS_Start to SP27:SAS_Settings

Deleted: 2

This transition shall occur after the RCDT timer expires if the current speed negotiation window is SNW-3 and the window is supported.

6.8.4.3 SP9:SAS_WindowNotSupported state

Deleted: RateNotSupported

6.8.4.3.1 State description

Upon entry into this state the SNTT timer shall be initialized and started.

During this state D.C. idle shall be transmitted.

6.8.4.3.2 Transition SP9:SAS_WindowNotSupported to SP14:SAS_Fail

Deleted: RateNotSupported

This transition shall occur after the SNTT timer expires.

6.8.4.4 SP10:SAS_AwaitALIGN state

6.8.4.4.1 State description

Upon entry into this state, the SNTT timer and SNLT timer shall be initialized and started and this state shall repeatedly send Transmit ALIGN (0) messages to the SP transmitter.

Each time this state receives a DWS Lost message, this state may send a Start DWS message to the SP_DWS state machine to re-acquire dword synchronization without running a new link reset sequence.

Upon entry into this state, this state shall send a Start DWS message to the SP_DWS state machine.

6.8.4.4.2 Transition SP10:SAS_AwaitALIGN to SP0:OOB_COMINIT

This transition shall occur after receiving a DWS Lost message if this state does not send a Start DWS message, or after receiving a COMINIT Detected message.

6.8.4.4.3 Transition SP10:SAS_AwaitALIGN to SP11:SAS_AwaitALIGN1

This transition shall occur if this state receives an ALIGN Received (0) message before the SNLT timer expires.

6.8.4.4.4 Transition SP10:SAS_AwaitALIGN to SP12:SAS_AwaitSNW

This transition shall occur if this state receives an ALIGN Received (1) message before the SNLT timer expires.

6.8.4.4.5 Transition SP10:SAS_AwaitALIGN to SP14:SAS_Fail

This transition shall occur if the SNTT timer expires.

6.8.4.5 SP11:SAS_AwaitALIGN1 state

6.8.4.5.1 State description

This state shall repeatedly send Transmit ALIGN (1) messages to the SP transmitter.

Each time this state receives a DWS Lost message, this state may send a Start DWS message to the SP_DWS state machine to re-acquire dword synchronization without running a new link reset sequence.

6.8.4.5.2 Transition SP11:SAS_AwaitALIGN1 to SP0:OOB_COMINIT

This transition shall occur after receiving a DWS Lost message if this state does not send a Start DWS message, or after receiving a COMINIT Detected message.

6.8.4.5.3 Transition SP11:SAS_AwaitALIGN1 to SP12:SAS_AwaitSNW

This transition shall occur if this state receives an ALIGN Received (1) message before the SNLT timer expires. This indicates that the other phy has been able to achieve dword synchronization in the current speed negotiation window.

6.8.4.5.4 Transition SP11:SAS_AwaitALIGN1 to SP14:SAS_Fail

This transition shall occur if the SNTT timer expires. This indicates that the other phy has not been able to achieve dword synchronization in the current speed negotiation window.

6.8.4.6 SP12:SAS_AwaitSNW state

6.8.4.6.1 State description

This state shall repeatedly send Transmit ALIGN (1) messages to the SP transmitter.

If this is [Final-SNW](#), this state shall send a Start SL_IR Receiver confirmation to the link layer.

Deleted: the final speed negotiation window

Each time this state receives a DWS Lost message, this state may send a Start DWS message to the SP_DWS state machine to re-acquire dword synchronization without running a new link reset sequence.

This state waits for the SNTT timer to expire or for a Stop SNTT request.

6.8.4.6.2 Transition SP12:SAS_AwaitSNW to SP0:OOB_COMINIT

This transition shall occur after receiving a DWS Lost message if this state does not send a Start DWS message, or after receiving a COMINIT Detected message.

6.8.4.6.3 Transition SP12:SAS_AwaitSNW to SP13:SAS_Pass

This transition shall occur after the SNTT timer expires or after receiving a Stop SNTT request.

6.8.4.7 SP13:SAS_Pass state

6.8.4.7.1 State description

This state determines if:

- a) another SAS speed negotiation window is required; or
- b) the SAS speed negotiation sequence is complete.

Each time this state receives a DWS Lost message, this state may send a Start DWS message to the SP_DWS state machine to re-acquire dword synchronization without running a new link reset sequence.

6.8.4.7.2 Transition SP13:SAS_Pass to SP0:OOB_COMINIT

This transition shall occur after receiving a DWS Lost message if this state does not send a Start DWS message, or after receiving a COMINIT Detected message.

6.8.4.7.3 Transition SP13:SAS_Pass to SP8:SAS_Start

This transition shall occur if this is not ~~Final-SNW~~.

6.8.4.7.4 Transition SP13:SAS_Pass to SP15:SAS_PHY_Ready

This transition shall occur if this is ~~Final-SNW~~.

6.8.4.8 SP14:SAS_Fail state

6.8.4.8.1 State description

This state determines if:

- a) another SAS speed negotiation window is required; or
- b) the SAS speed negotiation sequence is complete.

6.8.4.8.2 Transition SP14:SAS_Fail to SP1:OOB_AwaitCOMX

This transition shall occur if ~~the current speed negotiation window is Final-SNW~~.

6.8.4.8.3 Transition SP14:SAS_Fail to SP8:SAS_Start

~~This transition shall occur if the current speed negotiation window is not Final-SNW.~~

6.8.4.9 SP15:SAS_PHY_Ready state

6.8.4.9.1 State description

This state waits for a COMINIT Detected message, a DWS Lost message, or a DWS Reset message.

While in this state dwords from the link layer are transmitted at the negotiated physical link rate at the rate established in the previous speed negotiation window.

Upon entry into this state, this state shall send a Phy Layer Ready (SAS) confirmation to the link layer to indicate that the physical link has been brought up successfully in SAS mode.

Each time this state receives a DWS Lost message, this state may send a Start DWS message to the SP_DWS state machine to re-acquire dword synchronization without running a new link reset sequence.

Deleted: the final speed negotiation window

Deleted: ¶
This transition shall include a SAS Speed Negotiation Window Rate argument with the transition set to the next higher speed negotiation window rate.¶

Deleted: the final speed negotiation window

Deleted: :¶

Deleted: ¶
the current speed negotiation window is the maximum SAS speed negotiation window and the previous speed negotiation window was not successful; or¶

Deleted: the final SAS speed negotiation window

Deleted: <#>.¶

Deleted: If the previous SAS speed negotiation window (SNW-1 or SNW-2, but not SNW-3) was successful, this transition shall occur and shall include:¶

¶
<#>a SAS Speed Negotiation Window Rate argument set to the previous speed negotiation window rate; and¶
<#>a Final SAS Speed Negotiation Window argument.¶

¶
If the previous SAS speed negotiation window failed and the current speed negotiation window is not the maximum SAS speed negotiation window, this transition shall occur and shall include a SAS Speed Negotiation Window Rate argument set to the next higher speed negotiation window rate.

6.8.4.9.2 Transition SP15:SAS_PHY_Ready to SP0:OOB_COMINIT

This transition shall occur after:

- a) receiving a DWS Lost message, if this state does not send a Start DWS message;
- b) receiving a DWS Lost message followed by a COMINIT Detected message, if this state does not send a Start DWS message; or
- c) receiving a DWS Reset message.

This transition may but should not occur after receiving a COMINIT Detected message before receiving a DWS Lost message, or after receiving a COMINIT Detected message after sending a Start DWS message (i.e., the SP state machine should ignore COMINIT Detected messages unless the SP_DWS state machine has indicated loss of dword synchronization).

The remaining changes to clause 6.8.4 are all insertions of new paragraphs – exact paragraph number to be determined at time of incorporation into the SAS-2 draft.

6.8.4.10 SP27:SAS_Settings state**6.8.4.10.1 State description**

This state shall transmit and receive the settings bits and negotiate the common settings according to table 74.

Upon entry into this state, this state shall send Transmit Settings Bits message to the SP transmitter.

This state waits for the SNTT timer to expire.

6.8.4.10.2 Transition SP27:SAS_Settings to SP0:OOB_COMINIT

This transition shall occur after receiving a COMINIT Detected message.

This transition shall occur after the SNTT timer expires if a Settings Bits Detected message is received with an argument of invalid. This is a phy reset problem.

6.8.4.10.3 Transition SP27:SAS_Settings to SP8:SAS_Start

This transition shall occur if the SNTT timer expires and a Settings Bits Detected message is not received during this state.

6.8.4.10.4 Transition SP27:SAS_Settings to SP28:SAS_TrainSetup

This transition shall occur after the SNTT timer expires if a Settings Bits Detected message is received with an argument of valid.

6.8.4.11 SP28:SAS_TrainSetup**6.8.4.11.1 State description**

Upon entry into this state, this state shall:

- a) initialize and start the RCDT timer;
- b) send a Set Rate message to the SP transmitter and receiver with the arguments set to the highest, untried, commonly supported settings exchanged during SNW-3

During this state D.C. idle shall be transmitted.

6.8.4.11.2 Transition SP28:SAS_FinalSNW to SP0:OOB_COMINIT

This transition shall occur after receiving a COMINIT Detected message.

6.8.4.11.3 Transition SP28:SAS_FinalSNW to SP29:SAS_Train

This transition shall occur after the RCDT timer expires.

6.8.4.12 SP29:SAS_Train state

6.8.4.12.1 State description

Upon entry into this state:

- a) the MTT timer and TLT timer shall be initialized and started;
- b) a Start Training message shall be sent to the SP receiver; and
- c) a Start DWS message shall be sent to the SP_DWS state machine.

During this state Transmit TRAIN Pattern message shall be repeatedly sent to the SP transmitter.

Each time this state receives a DWS Lost message, this state may send a Start DWS message to the SP_DWS state machine to re-acquire dword synchronization without running a new link reset sequence.

6.8.4.12.2 Transition SP29:SAS_Train to SP0:OOB_COMINIT

This transition shall occur after receiving a DWS Lost message if this state does not send a Start DWS message, or after receiving a COMINIT Detected message.

This transition shall occur if the MTT timer expires and the common settings exchanged in SNW-3 have been exhausted. This indicates that this phy has not been able to complete training and achieve dword synchronization in the final speed negotiation window. This is a phy reset problem.

6.8.4.12.3 Transition SP29:SAS_Train to SP30:SAS_TrainingDone

This transition shall occur if this state receives a TRAIN Completed message before the TLT timer expires and dword synchronization is acquired.

6.8.4.12.4 Transition SP29:SAS_Train to SP28:SAS_TrainSetup

This transition shall occur if the MTT timer expires and the common settings exchanged in SNW-3 have not been exhausted. This indicates that this phy has not been able to complete training and achieve dword synchronization in the current speed negotiation window. This transition shall include an argument to indicate the next highest common settings of the received and transmitted settings in SNW-3 according to table 74.

6.8.4.13 SP30:SAS_TrainingDone state

6.8.4.13.1 State description

During this state shall repeatedly send Transmit TRAIN_DONE pattern message to the SP transmitter. A minimum of 4 TRAIN_DONE patterns must be transmitted.

Each time this state receives a DWS Lost message, this state may send a Start DWS message to the SP_DWS state machine to re-acquire dword synchronization without running a new link reset sequence.

This state waits for the MTT timer to expire or a TRAIN_DONE Detected message from the receiver.

This state shall send a Start SL_IR Receiver confirmation to the link layer when a TRAIN_DONE Detected message is received and dword synchronization is acquired.

6.8.4.13.2 Transition SP30:SAS_TrainingDone to SP0:OOB_COMINIT

This transition shall occur after receiving a DWS Lost message if this state does not send a Start DWS message, or after receiving a COMINIT Detected message.

This transition shall occur if TRAIN_DONE Detected message is not received before the MTT timer expires and the common settings exchanged in SNW-3 have been exhausted. This indicates that this phy has not been able to complete training and achieve dword synchronization in the final speed negotiation window. This is a phy reset problem.

6.8.4.13.3 Transition SP30:SAS_TrainingDone to SP28:SAS_TrainSetup

This transition shall occur if the MTT timer expires and the common settings exchanged in SNW-3 have not been exhausted. This indicates that the attached phy has not been able to complete training and achieve dword synchronization in the current speed negotiation window. This transition shall include an argument to indicate the next highest common settings of the received and transmitted settings in SNW-3 according to table 74.

6.8.4.13.4 Transition SP30:SAS_TrainingDone to SP15:SAS_PHY_Ready

This transition shall occur if this state has transmitted at least four TRAIN_DONE patterns, receives a TRAIN_DONE Detected message before the MTT timer expires. This indicates that the other phy has been able to complete training and achieve dword synchronization in the final speed negotiation window.

MTT	Maximum training time	29 998 080 OOBI ^e	The maximum time for training to complete during a Training-SNW.
SNWT	Speed negotiation window time	913 840 OOBI ^f	The duration of SNW-1, SNW-2, SNW-3, or a Final-SNW.
MTWT	Maximum Train-SNW window time	30 748 080 OOBI ^g	The maximum duration of the Train-SNW window. The duration of the Train-SNW may be less than RCDT + MTT.