

To: T10 Technical Committee
From: Tim Symons, PMC-Sierra (Tim_Symons@pmc-sierra.com)
Date: 11 May 2006
Subject: 06-098r5 SAS-2 Self-configuring expander device model

Revision Information

- Revision 0: Initial proposal
- Revision 1: Add text to clarify that self configuring devices configure attached non-self-configuring expander devices
 - Added text to allows that a discovery process may be initiated when a BROADCAST (CHANGE) is received on the subtractive port.
- Revision 2: Identify configuration topologies for reference of further discussion.
 - Added Domain Discovery
 - Added Neighbor discovery
- Revision 3: Removed unique behavior definitions for subtractive port. Added Full domain self discovery, and improved usage models
- Revision 4: Removed discarded concept definitions and models. Expanded the “full domain discovery” and added two more models.
- Revision 5: corrected figure title errors.

[Start: Changes in the latest revision are shown in red]

Referenced Documents

sas2r03a Serial Attached SCSI – 2 (SAS-2) revision 3
06-029 SAS-2 Expander configuration supervisor and SMP CHANGE request (Ralph Weber, ENDL and Steve Johnson, LSI Logic)
06-097r3 SAS-2 Configuring bit (Tim Symons, PMC-Sierra)
06-187 SAS-2 Self-configuring expander status (Rob Elliott, HP)
06-189 SAS-2 Allow table-to-table expander attachment (Rob Elliott, HP)

Overview

During working group discussions about SAS zoning there have been many questions regarding the definition of self-configuring devices and how a management application client in either an HBA or another self-configuring device should operate during discovery and configuration. This proposal provides reference usage models, definition of self-configuring devices and their expected behavior. Additions are recommended for the SAS-2 specification.

Discovery methods reviewed are:

- a) Single Master Domain discovery
- b) Nearest Neighbor discovery
- c) Full domain self discovery

Single Master Domain discovery is not preferred due to the requirement to elect a master and to disable all other self configuring devices, which has no previously defined mechanism.

Nearest Neighbor discovery is not preferred due to the effect of waiting for all neighbors to complete configuration prior to total discovery finalization and a potential for isolated “discovered” regions, without full topology resolution.

Full domain self discovery requires all management application clients to uniquely discover the domain topology however configuration of route tables shall be bounded by other self-configuring devices and limited to attached devices that are not self configuring. All management application clients interoperate independently to discover the topology. This offers the greatest

interoperability, and allows for future discovery optimizations to be implemented independently of pre-existing algorithms.

This version of the proposal defines a range of usage models to test implementation concepts

4.7.5.2 Topology configuration

4.7.5.2.1 Topology includes all configurable expanders and one HBA

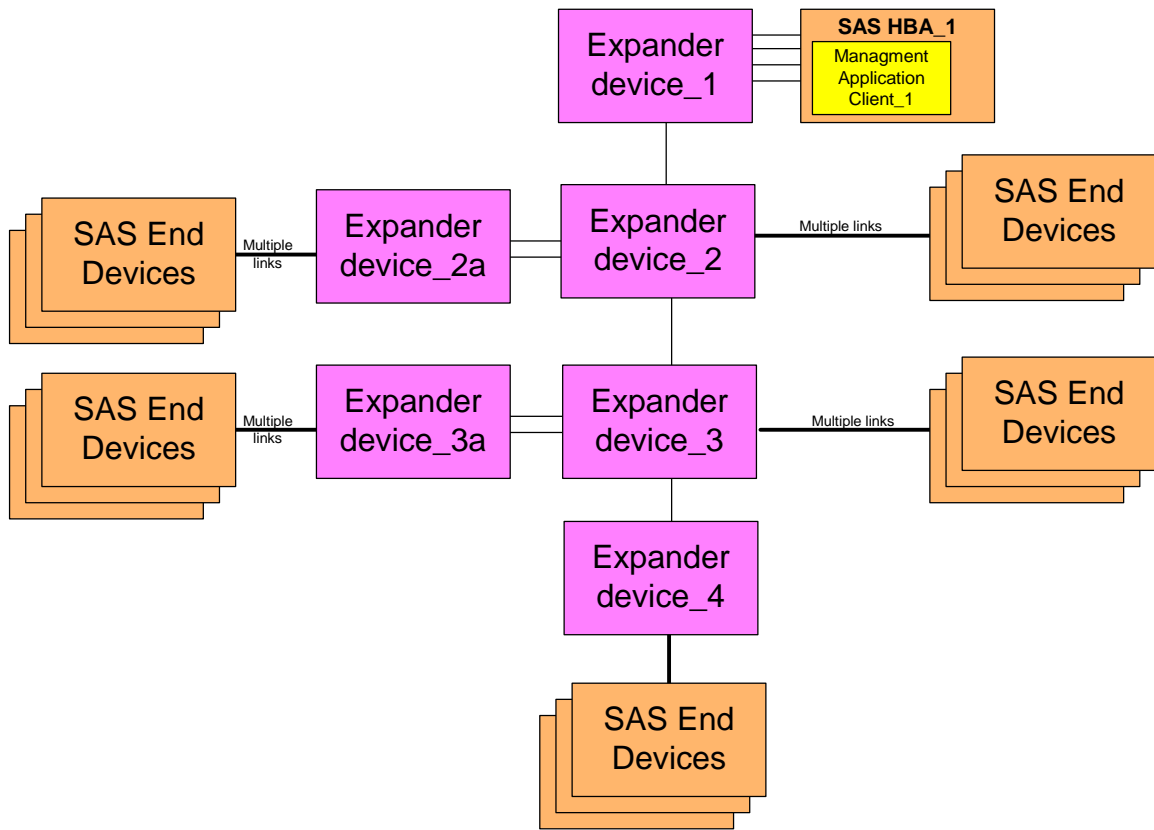

Figure 1 - No Self configuring expanders, one HBA

SAS HBA_1 configures all expander route tables.

Managing Application Client	Expander device configured by the management application client					
	1	2	2a	3	3a	4
HBA_1	√	√	√	√	√	√

4.7.5.2.2 Topology includes one self-configuring expander and one HBA

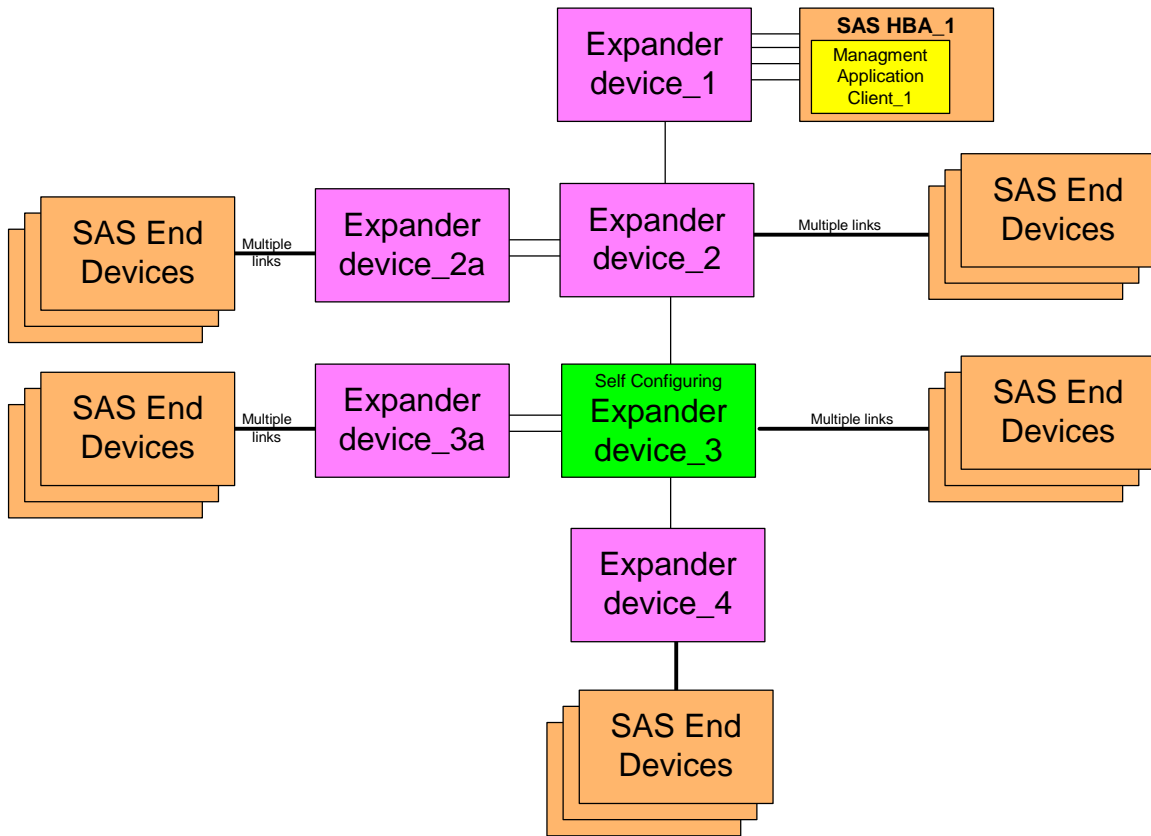

Figure 2 - One Self configuring expander, one HBA

Managing Application Client	Expander device configured by the management application client					
	1	2	2a	3	3a	4
HBA_1	√	√	√			
Expander device_3	√	√	√	√	√	√

Note : Gray Shading indicates self-configuring device

4.7.5.2.3 Topology includes one self-configuring expander and two HBAs

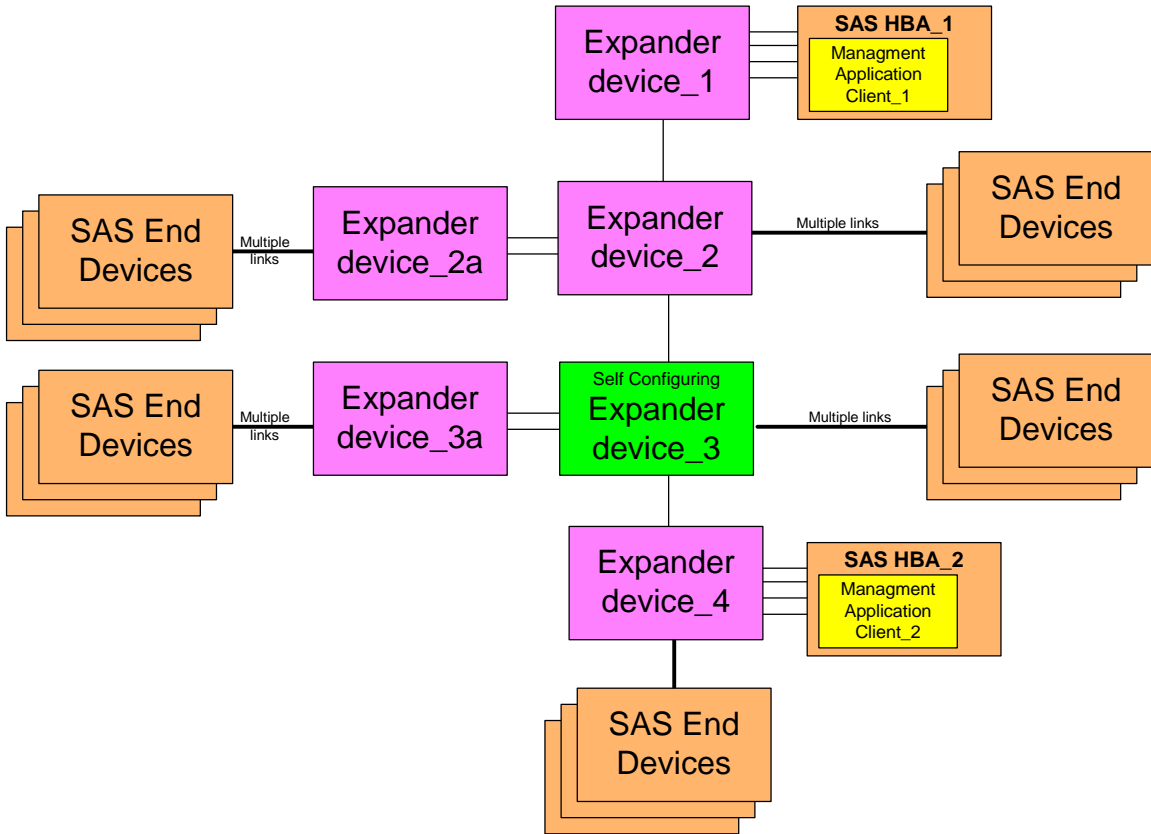

Figure 3 - One Self configuring expander, two HBAs

Managing Application Client	Expander device configured by the management application client					
	1	2	2a	3	3a	4
HBA_1	√	√	√			
Expander device_3	√	√	√	√	√	√
HBA_2						√

Note : Gray Shading indicates self-configuring device

4.7.5.2.4 Topology includes two self-configuring expander and two HBAs

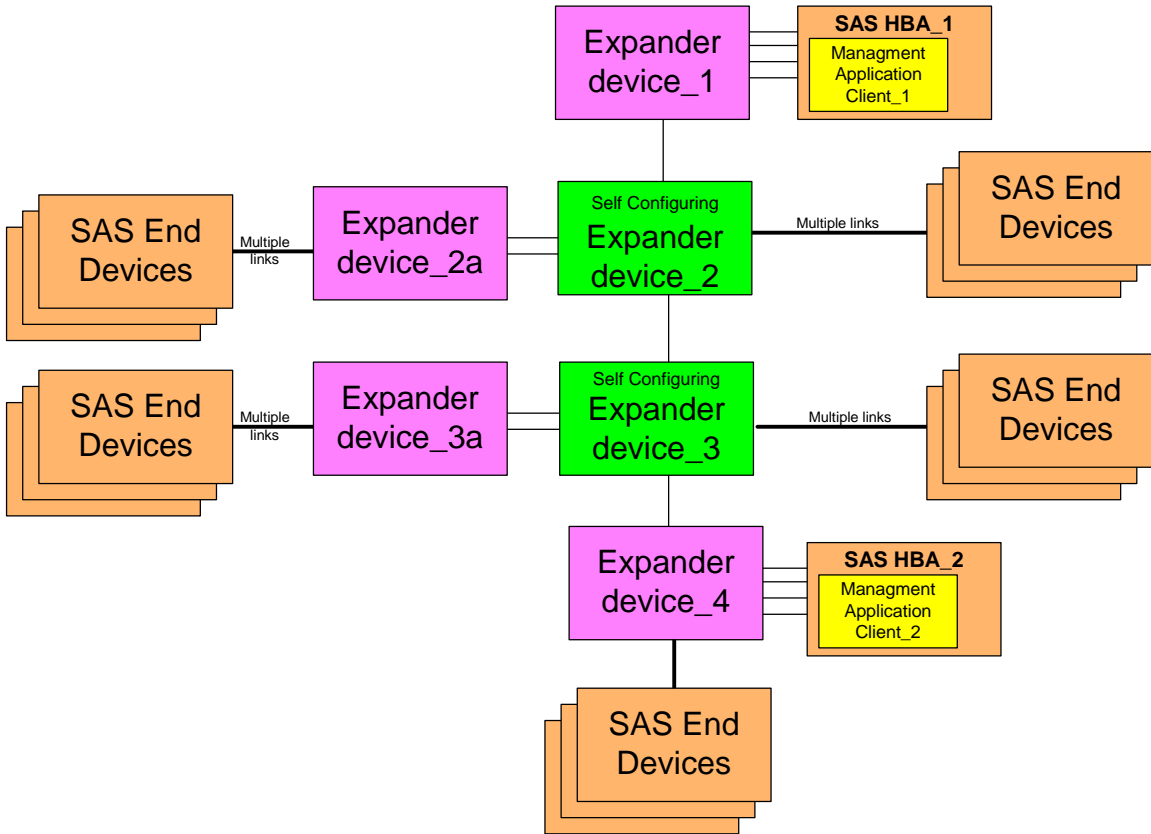

Figure 4 - Two Self configuring expanders, two HBAs

Managing Application Client	Expander device configured by the management application client					
	1	2	2a	3	3a	4
HBA_1	√					
Expander device_2	√	√	√			
Expander device_3				√	√	√
HBA_2						√

Note : Gray Shading indicates self-configuring device

4.7.5.2.5 Topology includes two self-configuring expander and two HBAs

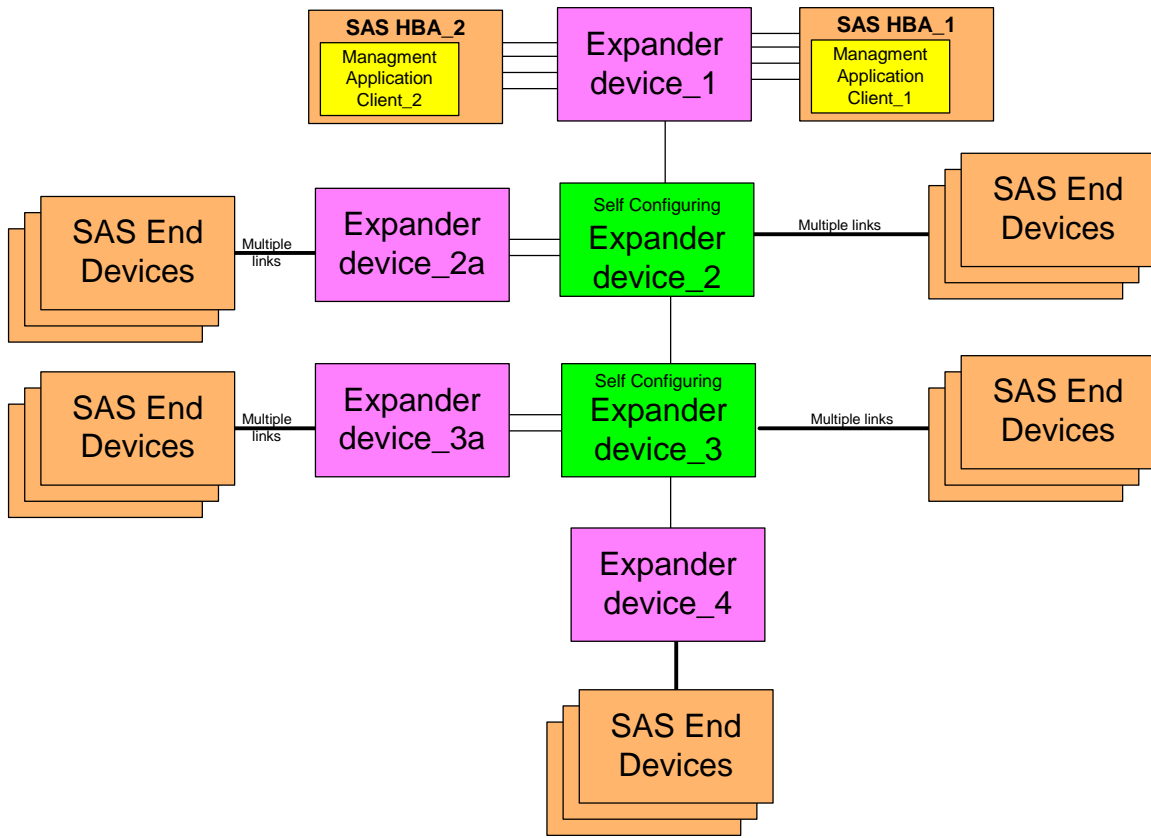

Figure 5 - Two Self configuring expanders, two HBAs

Managing Application Client	Expander device configured by the management application client					
	1	2	2a	3	3a	4
HBA_1	√					
HBA_2	√					
Expander device_2	√	√	√			
Expander device_3				√	√	√

Note : Gray Shading indicates self-configuring device

4.7.5.2.6 Topology includes two self-configuring expander and two HBAs

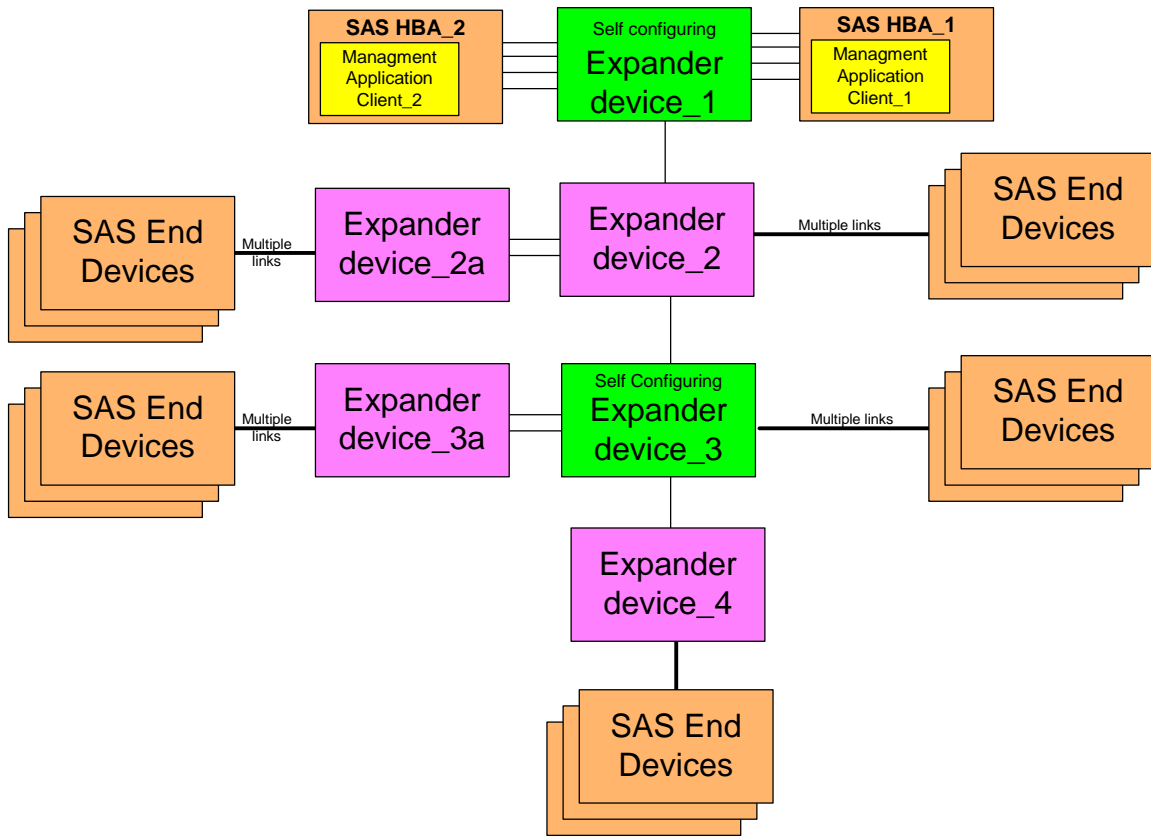

Figure 6 - Two Self configuring expanders, two HBAs

Managing Application Client	Expander device configured by the management application client					
	1	2	2a	3	3a	4
HBA_1						
HBA_2						
Expander device_1	√	√	√			
Expander device_3		√	√	√	√	√

Note : Gray Shading indicates self-configuring device

4.7.5.2.7 Topology includes all self-configuring expander and two HBAs

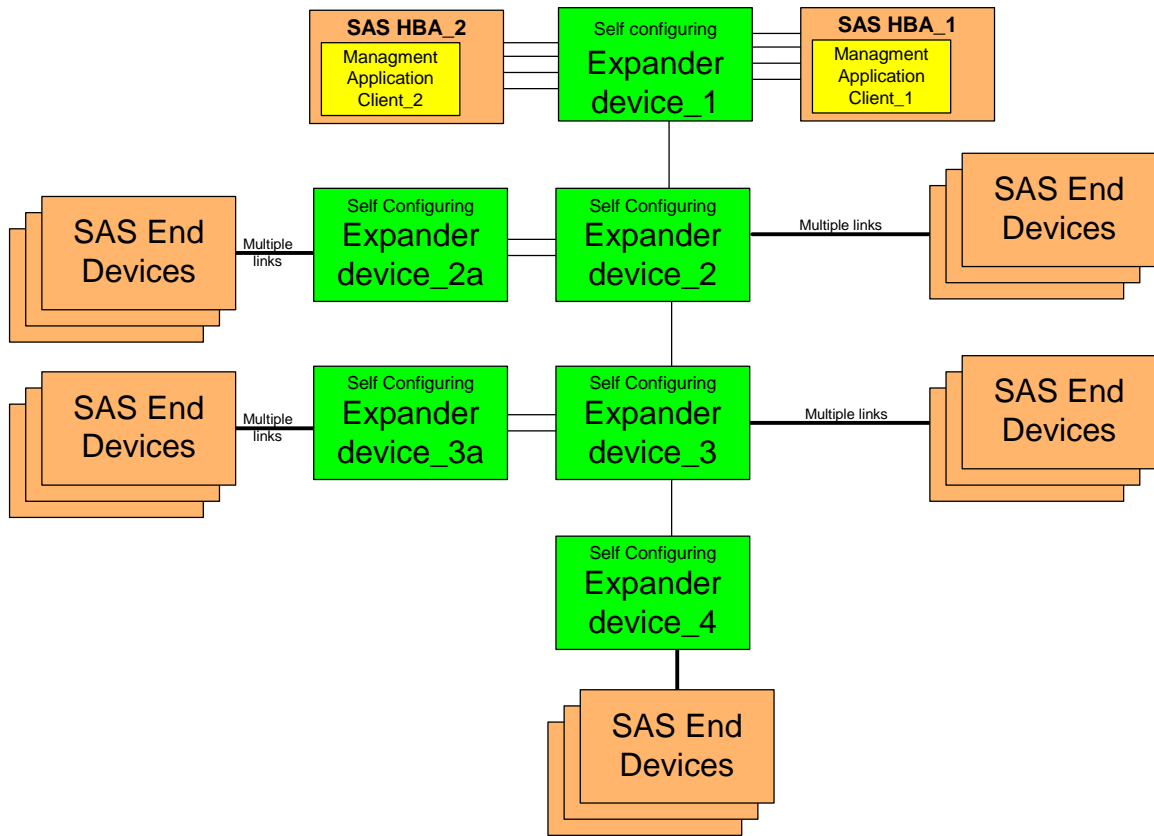

Figure 7 - All Self configuring expanders, two HBAs

Managing Application Client	Expander device configured by the management application client					
	1	2	2a	3	3a	4
HBA_1						
HBA_2						
Expander device_1	√					
Expander device_2		√				
Expander device_2a			√			
Expander device_3				√		
Expander device_3a					√	
Expander device_4						√

Note : Gray Shading indicates self-configuring device

4.7.5.2.8 Topology includes one self-configuring expander and one HBA with no management application client

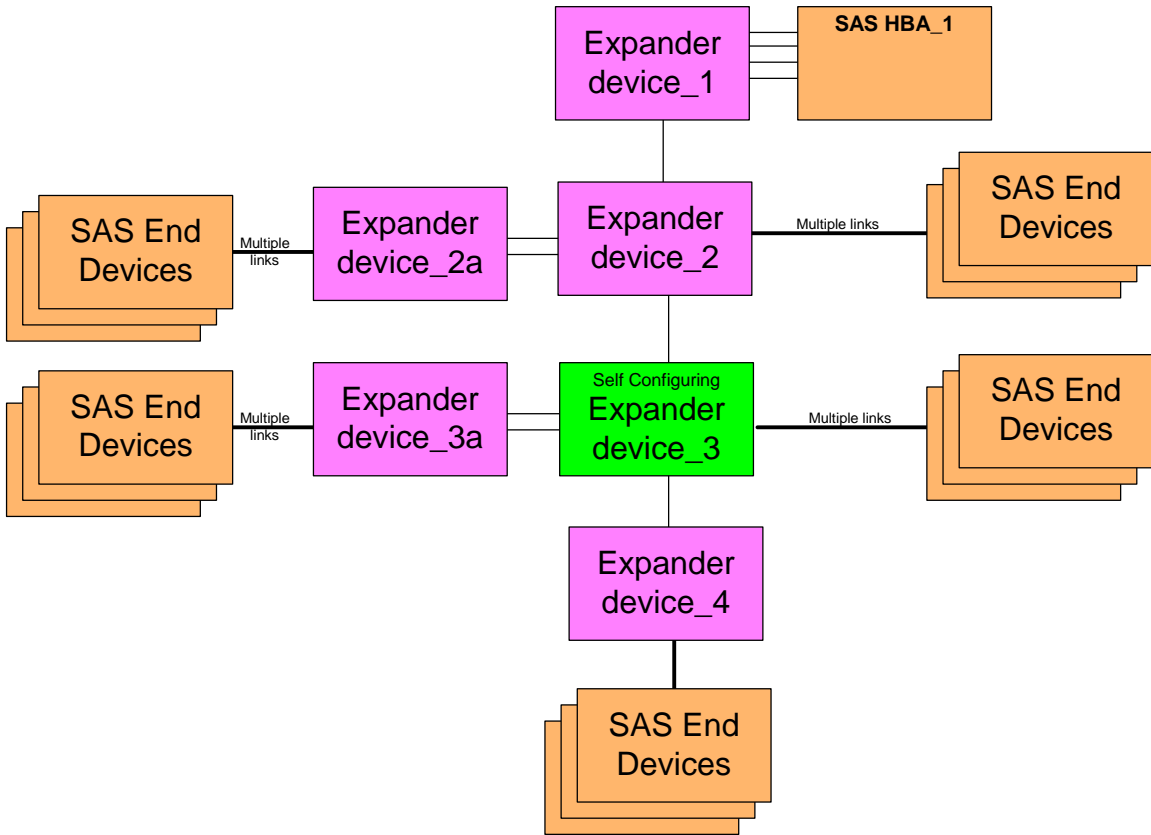

Figure 8 - One Self configuring expander, one HBA (with no management application client)

Managing Application Client	Expander device configured by the management application client					
	1	2	2a	3	3a	4
HBA_1 (with no management application client)						
Expander device_3	√	√	√	√	√	√

Note : Gray Shading indicates self-configuring device