

T10/05-369 revision 0

Date: September 20, 2005

To: T10 Committee (SCSI)

From: George Penokie (IBM/Tivoli)

Subject: Proposed SBC-3 Revision 02

1 Overview

The following is a proposal for revision 02 of SCSI Block Commands - 3 (SBC-3).

Working Draft American National Standard

Project T10/xxxx-D

Revision 2
22 September 2005

Information technology - SCSI Block Commands - 3 (SBC-3)

This is an internal working document of T10, a Technical Committee of Accredited Standards Committee INCITS (International Committee for Information Technology Standards). As such this is not a completed standard and has not been approved. The contents may be modified by the T10 Technical Committee. The contents are actively being modified by T10. This document is made available for review and comment only.

Permission is granted to members of INCITS, its technical committees, and their associated task groups to reproduce this document for the purposes of INCITS standardization activities without further permission, provided this notice is included. All other rights are reserved. Any duplication of this document for commercial or for-profit use is strictly prohibited.

T10 Technical Editor: TBD
TBD
TBD
TBD
USA

Telephone: TBD
Email: TBD

Reference number
ISO/IEC 14776-xxx:200x
ANSI INCITS.***:200x

Points of contact

International Committee for Information Technology Standards (INCITS) T10 Technical Committee

T10 Chair

John B. Lohmeyer
LSI Logic
4420 Arrows West Drive
Colorado Springs, CO 80907-3444
USA

Telephone: (719) 533-7560
Email: lohmeyer@t10.org

T10 Web Site: <http://www.t10.org>

T10 Vice-Chair

George O. Penokie
IBM Corporation
MS: 2C6
3605 Highway 52 N
Rochester, MN 55901
USA

Telephone: (507) 253-5208
Email: gop@us.ibm.com

T10 E-mail reflector:

Server: majordomo@t10.org
To subscribe send e-mail with 'subscribe' in message body
To unsubscribe send e-mail with 'unsubscribe' in message body

INCITS Secretariat

Suite 200
1250 Eye Street, NW
Washington, DC 20005
USA

Telephone: 202-737-8888
Web site: <http://www.incits.org>
Email: incits@itic.org

Information Technology Industry Council

Web site: <http://www.itic.org>

Document Distribution

INCITS Online Store
managed by Techstreet
1327 Jones Drive
Ann Arbor, MI 48105
USA

Web site: <http://www.techstreet.com/incits.html>
Telephone: (734) 302-7801 or (800) 699-9277

Global Engineering Documents, an IHS Company
15 Inverness Way East
Englewood, CO 80112-5704
USA

Web site: <http://global.ihs.com>
Telephone: (303) 397-7956 or (303) 792-2181 or (800) 854-7179

American National Standard
for Information Technology

SCSI Block Commands - 3 (SBC-3)

Secretariat
Information Technology Industry Council

Approved mm.dd.yy
American National Standards Institute, Inc.

ABSTRACT

This standard specifies the functional requirements for the SCSI Block Commands - 3 (SBC-3) command set. SBC-3 permits SCSI block logical units such as rigid disks to attach to computers and provides the definition for their use.

This standard maintains a high degree of compatibility with the SCSI Block Commands (SBC-2) command set, INCITS 405-2005, and while providing additional functions, is not intended to require changes to presently installed devices or existing software.

American National Standard

Approval of an American National Standard requires verification by ANSI that the requirements for due process, consensus, and other criteria for approval have been met by the standards developer. Consensus is established when, in the judgment of the ANSI Board of Standards Review, substantial agreement has been reached by directly and materially affected interests. Substantial agreement means much more than a simple majority, but not necessarily unanimity. Consensus requires that all views and objections be considered, and that effort be made towards their resolution.

The use of American National Standards is completely voluntary; their existence does not in any respect preclude anyone, whether he has approved the standards or not, from manufacturing, marketing, purchasing, or using products, processes, or procedures not conforming to the standards.

The American National Standards Institute does not develop standards and will in no circumstances give interpretation on any American National Standard. Moreover, no person shall have the right or authority to issue an interpretation of an American National Standard in the name of the American National Standards Institute. Requests for interpretations should be addressed to the secretariat or sponsor whose name appears on the title page of this standard.

CAUTION NOTICE: This American National Standard may be revised or withdrawn at any time. The procedures of the American National Standards Institute require that action be taken periodically to reaffirm, revise, or withdraw this standard. Purchasers of American National Standards may receive current information on all standards by calling or writing the American National Standards Institute.

CAUTION: The developers of this standard have requested that holders of patents that may be required for the implementation of the standard, disclose such patents to the publisher. However, neither the developers nor the publisher have undertaken a patent search in order to identify which, if any, patents may apply to this standard. As of the date of publication of this standard, following calls for the identification of patents that may be required for the implementation of the standard, no such claims have been made. No further patent search is conducted by the developer or the publisher in respect to any standard it processes. No representation is made or implied that licenses are not required to avoid infringement in the use of this standard.

Published by

**American National Standards Institute
11 W. 42nd Street, New York, New York 10036**

Copyright © 2004 by Information Technology Industry Council (ITI).
All rights reserved.

No part of this publication may be reproduced in any form, in an electronic retrieval system or otherwise, without prior written permission of ITI, 1250 Eye Street NW, Suite 200, Washington, DC 20005.

Printed in the United States of America

Revision Information

R.1 Revision 0 (09 September 2005)

Revision 0 of SBC-3 is substantially equal to revision 16 of SBC-2. The only differences arise from changes made in SBC-2 discovered during the ISO process. Those changes include:

- a) Changed idle condition timer to standby condition timer in item c) of subclause 4.15.1.
- b) Changed 2 Gigabytes to 1 GiB and 2 Terabytes to 2 TiB in two places in note 10 in subclause 5.5. The 2 was change to a 1 because there are 21 bits in the LOGICAL BLOCK ADDRESS field (i.e., 1F_FFFF is 2,097,151 that * 512 is 1,073,741,312 which is 1 GiB).

Removed the CORRCT bit from the WRITE LONG (16) CDB as it was never supposed to be added to this command. It's not in SCSI-2 or SBC for WRITE LONG (10) and 03-383r1 did not ask for it. It showed up in sbc2r11.

R.2 Revision 1 (16 September 2005)

- a) Incorporated the following proposals:
 - A) 04-198r5 - Background Media Scan;
 - B) 04-371r2 - SPC-4: Enable Background Operation Error Reporting Bit; and
 - C) 05-101r1 - SBC-2 Validation of Protection Information.

R.3 Revision 2 (22 September 2005)

- a) Incorporated the following proposals:
 - A) 05-299r1 - Correct Log Page Format Tables in SPC-4, SBC-3, & SAS-2; and
 - B) 05-313r0 - SBC-3: Change to background medium scan.

Contents

	Page
1 Scope	1
2 Normative References	2
2.1 Normative references overview	2
2.2 Approved references	2
2.3 References under development	3
3 Definitions, symbols, abbreviations, keywords, and conventions	4
3.1 Definitions	4
3.2 Symbols and abbreviations	6
3.3 Keywords	7
3.4 Conventions	7
4 Direct-access block device type model	9
4.1 Direct-access block device type model overview	9
4.2 Media examples	9
4.2.1 Media examples overview	9
4.2.2 Rotating media	9
4.2.3 Memory media	10
4.3 Removable medium	10
4.3.1 Removable medium overview	10
4.3.2 Removable medium with an attached media changer	10
4.4 Logical blocks	11
4.5 Ready state	11
4.6 Initialization	12
4.7 Write protection	12
4.8 Medium defects	13
4.9 Write failures	13
4.10 Caches	14
4.11 Implicit HEAD OF QUEUE command processing	15
4.12 Reservations	15
4.13 Error reporting	17
4.13.1 Error reporting overview	17
4.13.2 Block commands sense data descriptor	18
4.14 Model for XOR commands	18
4.14.1 Model for XOR commands overview	18
4.14.2 Storage array controller supervised XOR operations	19
4.14.2.1 Storage array controller supervised XOR operations overview	19
4.14.2.2 Update write operation	19
4.14.2.3 Regenerate operation	19
4.14.2.4 Rebuild operation	20
4.14.3 Array subsystem considerations	20
4.14.3.1 Array subsystem considerations overview	20
4.14.3.2 Buffer full status handling	20
4.14.3.3 Access to an inconsistent stripe	20
4.14.4 XOR data retention requirements	21
4.15 START STOP UNIT and power conditions	21
4.15.1 START STOP UNIT and power conditions overview	21
4.15.2 START STOP UNIT and power conditions state machine	22
4.15.2.1 START STOP UNIT and power conditions state machine overview	22
4.15.2.2 SSU_PC0:Powered_on state	23
4.15.2.2.1 SSU_PC0:Powered_on state description	23
4.15.2.2.2 Transition SSU_PC0:Powered_on to SSU_PC1:Active	23
4.15.2.2.3 Transition SSU_PC0:Powered_on to SSU_PC4:Stopped	23

4.15.2.3 SSU_PC1:Active state	23
4.15.2.3.1 SSU_PC1:Active state description	23
4.15.2.3.2 Transition SSU_PC1:Active to SSU_PC2:Idle.....	23
4.15.2.3.3 Transition SSU_PC1:Active to SSU_PC3:Standby	23
4.15.2.3.4 Transition SSU_PC1:Active to SSU_PC4:Stopped	23
4.15.2.4 SSU_PC2:Idle state	23
4.15.2.4.1 SSU_PC2:Idle state description	23
4.15.2.4.2 Transition SSU_PC2:Idle to SSU_PC1:Active.....	24
4.15.2.4.3 Transition SSU_PC2:Idle to SSU_PC3:Standby	24
4.15.2.4.4 Transition SSU_PC2:Idle to SSU_PC4:Stopped	24
4.15.2.5 SSU_PC3:Standby state	24
4.15.2.5.1 SSU_PC3:Standby state description	24
4.15.2.5.2 Transition SSU_PC3:Standby to SSU_PC1:Active	24
4.15.2.5.3 Transition SSU_PC3:Standby to SSU_PC2:Idle	24
4.15.2.5.4 Transition SSU_PC3:Standby to SSU_PC4:Stopped.....	24
4.15.2.6 SSU_PC4:Stopped state.....	25
4.15.2.6.1 SSU_PC4:Stopped state description.....	25
4.15.2.6.2 Transition SSU_PC4:Stopped to SSU_PC1:Active	25
4.15.2.6.3 Transition SSU_PC4:Stopped to SSU_PC2:Idle	25
4.15.2.6.4 Transition SSU_PC4:Stopped to SSU_PC3:Standby.....	25
4.16 Protection information model.....	25
4.16.1 Protection information overview	25
4.16.2 Protection information format.....	26
4.16.3 Logical block guard	26
4.16.3.1 Logical block guard overview	26
4.16.3.2 CRC generation.....	27
4.16.3.3 CRC checking	28
4.16.3.4 CRC test cases	28
4.16.4 Application of protection information.....	28
4.16.5 Protection information and commands	28
4.17 Grouping function	29
4.18 Background scanning operations	29
4.18.1 Background scanning overview	29
4.18.2 Background pre-scan feature.....	29
4.18.2.1 Enabling background pre-scan operation.....	29
4.18.2.2 Halting background pre-scan operation	30
4.18.3 Background medium scan feature	30
4.18.3.1 Enabling background medium scan operation	30
4.18.3.2 Suspending background medium scan operation	30
4.18.4 Interpreting the logged results	30
5 Commands for direct-access block devices.....	32
5.1 Commands for direct-access block devices overview	32
5.2 FORMAT UNIT command	35
5.2.1 FORMAT UNIT command overview	35
5.2.2 FORMAT UNIT parameter list.....	39
5.2.2.1 FORMAT UNIT parameter list overview	39
5.2.2.2 Parameter list header	39
5.2.2.3 Initialization pattern descriptor.....	41
5.2.2.4 Address descriptor formats	43
5.2.2.4.1 Address descriptor formats overview.....	43
5.2.2.4.2 Short block format address descriptor	44
5.2.2.4.3 Long block format address descriptor.....	44
5.2.2.4.4 Bytes from index format address descriptor	44
5.2.2.4.5 Physical sector format address descriptor	45
5.3 PRE-FETCH (10) command.....	45
5.4 PRE-FETCH (16) command.....	46

5.5 READ (6) command	47
5.6 READ (10) command	48
5.7 READ (12) command	52
5.8 READ (16) command	53
5.9 READ (32) command	53
5.10 READ CAPACITY (10) command	55
5.10.1 READ CAPACITY (10) overview	55
5.10.2 READ CAPACITY (10) parameter data	55
5.11 READ CAPACITY (16) command	56
5.11.1 READ CAPACITY (16) command overview.....	56
5.11.2 READ CAPACITY (16) parameter data	57
5.12 READ DEFECT DATA (10) command	57
5.12.1 READ DEFECT DATA (10) command overview.....	57
5.12.2 READ DEFECT DATA (10) parameter data	58
5.13 READ DEFECT DATA (12) command	59
5.13.1 READ DEFECT DATA (12) command overview.....	59
5.13.2 READ DEFECT DATA (12) parameter data	60
5.14 READ LONG (10) command	60
5.15 READ LONG (16) command	61
5.16 REASSIGN BLOCKS command.....	62
5.16.1 REASSIGN BLOCKS command overview.....	62
5.16.2 REASSIGN BLOCKS parameter list	62
5.17 START STOP UNIT command.....	63
5.18 SYNCHRONIZE CACHE (10) command.....	65
5.19 SYNCHRONIZE CACHE (16) command.....	66
5.20 VERIFY (10) command	67
5.21 VERIFY (12) command	76
5.22 VERIFY (16) command	77
5.23 VERIFY (32) command	77
5.24 WRITE (6) command.....	79
5.25 WRITE (10) command.....	79
5.26 WRITE (12) command.....	83
5.27 WRITE (16) command.....	84
5.28 WRITE (32) command.....	84
5.29 WRITE AND VERIFY (10) command	86
5.30 WRITE AND VERIFY (12) command	86
5.31 WRITE AND VERIFY (16) command	87
5.32 WRITE AND VERIFY (32) command	87
5.33 WRITE LONG (10) command.....	89
5.34 WRITE LONG (16) command.....	89
5.35 WRITE SAME (10) command.....	90
5.36 WRITE SAME (16) command.....	91
5.37 WRITE SAME (32) command.....	92
5.38 XDREAD (10) command	94
5.39 XDREAD (32) command	95
5.40 XDWRITE (10) command.....	95
5.41 XDWRITE (32) command.....	96
5.42 XDWRITEREAD (10) command.....	97
5.43 XDWRITEREAD (32) command.....	98
5.44 XPWRITE (10) command	99
5.45 XPWRITE (32) command	100
6 Parameters for direct-access block devices.....	102
6.1 Diagnostic parameters.....	102
6.1.1 Diagnostic parameters overview	102
6.1.2 Translate Address Output diagnostic page.....	102
6.1.3 Translate Address Input diagnostic page.....	103

6.2 Log parameters	105
6.2.1 Log parameters overview.....	105
6.2.2 Background Scan Results log page.....	105
6.2.3 Format Status log page.....	109
6.2.4 Non-volatile Cache log page.....	110
6.3 Mode parameters	111
6.3.1 Mode parameters overview.....	111
6.3.2 Mode parameter block descriptors.....	114
6.3.2.1 Mode parameter block descriptors overview.....	114
6.3.2.2 Short LBA mode parameter block descriptor	114
6.3.2.3 Long LBA mode parameter block descriptor	116
6.3.3 Background Control mode page	117
6.3.4 Caching mode page.....	118
6.3.5 Read-Write Error Recovery mode page.....	121
6.3.6 Verify Error Recovery mode page.....	126
6.3.7 XOR Control mode page.....	127
6.4 Vital product data (VPD) parameters.....	127
6.4.1 VPD parameters overview	127
6.4.2 Block Limits VPD page	128
Annex A Numeric order codes	130
A.1 Variable length CDBs.....	130
A.2 Service action CDBs	130
Annex B XOR command examples.....	132
B.1 XOR command examples overview	132
B.2 Update write operation	132
B.3 Regenerate operation	133
B.4 Rebuild operation	134
Annex C CRC example in C.....	136

Tables

	Page
1 Standards bodies	2
2 ISO and American numbering convention examples	8
3 SBC-2 commands that are allowed in the presence of various reservations	16
4 Example error conditions	17
5 Sense data field usage for direct-access block devices	17
6 Block commands sense data descriptor format	18
7 User data and protection information format	26
8 CRC polynomials	27
9 CRC test cases	28
10 Commands for direct-access block devices	32
11 FORMAT UNIT command	36
12 FORMAT UNIT command address descriptor usage	38
13 FORMAT UNIT parameter list	39
14 Short parameter list header	39
15 Long parameter list header	40
16 Initialization pattern descriptor	41
17 Initialization pattern modifier (IP MODIFIER) field	42
18 INITIALIZATION PATTERN TYPE field	43
19 Address descriptor formats	43
20 Short block format address descriptor (000b)	44
21 Long block format address descriptor (011b)	44
22 Bytes from index format address descriptor (100b)	44
23 Physical sector format address descriptor (101b)	45
24 PRE-FETCH (10) command	45
25 PRE-FETCH (16) command	47
26 READ (6) command	47
27 Protection information checking for READ (6)	48
28 READ (10) command	49
29 RDPROTECT field	49
30 Force unit access for read operations	52
31 READ (12) command	53
32 READ (16) command	53
33 READ (32) command	54
34 READ CAPACITY (10) command	55
35 READ CAPACITY (10) parameter data	55
36 READ CAPACITY (16) command	56
37 READ CAPACITY (16) parameter data	57
38 READ DEFECT DATA (10) command	57
39 READ DEFECT DATA (10) parameter data	58
40 READ DEFECT DATA (12) command	59
41 READ DEFECT DATA (12) parameter data	60
42 READ LONG (10) command	60
43 READ LONG (16) command	61
44 REASSIGN BLOCKS command	62
45 REASSIGN BLOCKS parameter list	62
46 REASSIGN BLOCKS short parameter list header	63
47 REASSIGN BLOCKS long parameter list header	63
48 START STOP UNIT command	64
49 POWER CONDITION field	64
50 SYNCHRONIZE CACHE (10) command	65
51 SYNC_NV bit	66
52 SYNCHRONIZE CACHE (16) command	66
53 VERIFY (10) command	67
54 VRPROTECT field with BYTCHK set to zero - checking protection information read from the medium	68
55 VRPROTECT field with BYTCHK set to one - checking protection information read from the medium	71

56 VRPROTECT field with BYTCHK set to one - checking protection information from the data-out buffer	72
57 VRPROTECT field with BYTCHK set to one - byte-by-byte comparison requirements	75
58 VERIFY (12) command	77
59 VERIFY (16) command	77
60 VERIFY (32) command	78
61 WRITE (6) command	79
62 WRITE (10) command	80
63 WRPROTECT field	80
64 Force unit access for write operations	83
65 WRITE (12) command	83
66 WRITE (16) command	84
67 WRITE (32) command	85
68 WRITE AND VERIFY (10) command	86
69 WRITE AND VERIFY (12) command	87
70 WRITE AND VERIFY (16) command	87
71 WRITE AND VERIFY (32) command	88
72 WRITE LONG (10) command	89
73 WRITE LONG (16) command	90
74 WRITE SAME (10) command	90
75 LBDATA bit and PBDATA bit	91
76 WRITE SAME (16) command	92
77 WRITE SAME (32) command	93
78 XDREAD (10) command	94
79 XDREAD (32) command	95
80 XDWRITE (10) command	96
81 XDWRITE (32) command	97
82 XDWRITEREAD (10) command	98
83 XDWRITEREAD (32) command	99
84 XPWRITE (10) command	100
85 XPWRITE (32) command	101
86 Diagnostic page codes	102
87 Translate Address Output diagnostic page	102
88 Translate Address Input diagnostic page	103
89 Log page codes	105
90 Background Scan Results log page	106
91 Background Scan Results log page parameter codes	106
92 Background scanning status parameter format	107
93 BACKGROUND SCANNING STATUS field	107
94 Medium scan parameter format	108
95 REASSIGN STATUS field	108
96 Format Status log page parameter codes	109
97 Non-volatile Cache log page	110
98 Non-volatile Cache log parameters	110
99 Remaining Non-volatile Time parameter data	110
100 REMAINING NON-VOLATILE TIME field	111
101 Maximum Non-volatile Time parameter data	111
102 MAXIMUM NON-VOLATILE TIME field	111
103 DEVICE-SPECIFIC PARAMETER field for direct-access block devices	112
104 Mode page codes for direct-access block devices	113
105 Short LBA mode parameter block descriptor	114
106 Long LBA mode parameter block descriptor	116
107 Background Control mode page	117
108 Caching mode page	118
109 DEMAND READ RETENTION PRIORITY field	119
110 WRITE RETENTION PRIORITY field	120
111 Read-Write Error Recovery mode page	121
112 Combined error recovery bit descriptions	123

113 Verify Error Recovery mode page 126
114 XOR Control mode page 127
115 Direct-access block device VPD page codes 128
116 Block Limits VPD page 128
A.1 Variable length command service action code assignments 130
A.2 SERVICE ACTION IN (16) service actions 130
A.3 SERVICE ACTION OUT (16) service actions 131

Figures

	Page
1 SCSI document relationships	1
2 Power condition state machine for logical units implementing the START STOP UNIT command	22
B.1 Update write operation (storage array controller supervised)	133
B.2 Regenerate operation (storage array controller supervised)	134
B.3 Rebuild operation (storage array controller supervised)	135

Foreword (This foreword is not part of this standard)

Requests for interpretation, suggestions for improvement and addenda, or defect reports are welcome. They should be sent to the INCITS Secretariat, International Committee for Information Technology Standards, Information Technology Institute, 1250 Eye Street, NW, Suite 200, Washington, DC 20005-3922.

This standard was processed and approved for submittal to ANSI by the International Committee for Information Technology Standards (INCITS). Committee approval of the standard does not necessarily imply that all committee members voted for approval. At the time it approved this standard, INCITS had the following members:

Karen Higginbottom, Chair

David Michael, Vice-Chair

INCITS Technical Committee T10 - SCSI Storage Interfaces, which developed and reviewed this standard, had the following members:

John B. Lohmeyer, Chair

George O. Penokie, Vice-Chair

Ralph O. Weber, Secretary

Introduction

The standard is organized as follows:

Clause 1 (Scope) describes the relationship of this standard to the SCSI family of standards.

Clause 2 (Normative References) provides references to other standards and documents.

Clause 3 (Definitions, symbols, abbreviations, keywords, and conventions) defines terms and conventions used throughout this standard.

Clause 4 (Direct-access block device type model) provides an overview of the direct-access block device type and the command set.

Clause 5 (Commands for direct-access block devices) defines commands specific to direct-access block devices.

Clause 6 (Parameters for direct-access block devices) defines diagnostic pages, mode parameters and pages, log pages, and VPD pages specific to direct-access block devices.

Informative Annex A (Numeric order codes) summarizes service action assignments for variable-length commands and commands using the SERVICE ACTION IN and SERVICE ACTION OUT operation codes.

Informative Annex B (XOR command examples) provides examples of XOR command usage.

Informative Annex C (CRC example in C) provides example C code for the protection information CRC.

**American National Standard
for Information Technology -**

SCSI Block Commands - 3 (SBC-3)

1 Scope

This standard defines the command set extensions to facilitate operation of SCSI direct-access block devices. The clauses of this standard, implemented in conjunction with the applicable clauses of SPC-4, fully specify the standard command set for SCSI direct-access block devices.

The objective of this standard is to:

- a) permit an application client to communicate over a SCSI service delivery subsystem with a logical unit that declares itself to be a direct-access block device in the PERIPHERAL DEVICE TYPE field of the standard INQUIRY data (see SPC-4); and
- b) define commands unique to the direct-access block device type.

Figure 1 shows the relationship of this standard to the other standards and related projects in the SCSI family of standards.

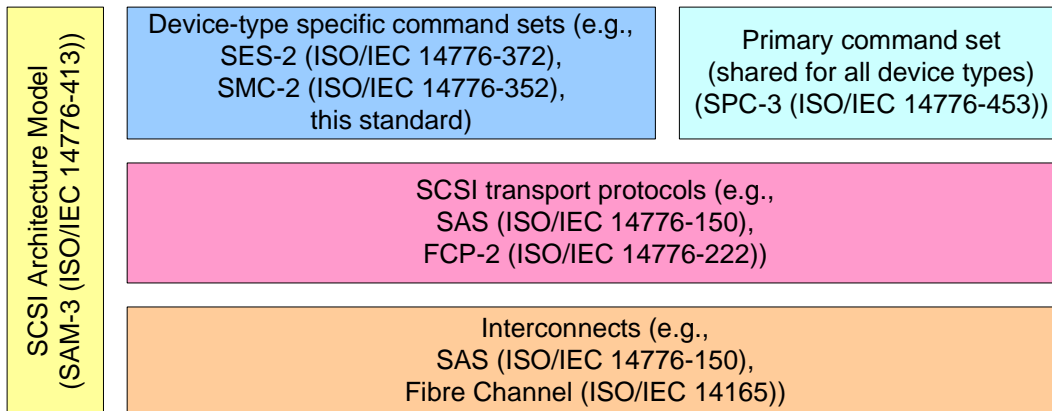

Figure 1 — SCSI document relationships

Figure 1 is intended to show the general relationship of the documents to one another, and is not intended to imply a relationship such as a hierarchy, protocol stack, or system architecture.

The set of SCSI standards specifies the interfaces, functions, and operations necessary to ensure interoperability between conforming SCSI implementations. This standard is a functional description. Conforming implementations may employ any design technique that does not violate interoperability.

This standard makes obsolete the following concepts from previous standards:

- a)

2 Normative References

2.1 Normative references overview

The following standards contain provisions that, by reference in the text, constitute provisions of this standard. At the time of publication, the editions indicated were valid. All standards are subject to revision, and parties to agreements based on this standard are encouraged to investigate the possibility of applying the most recent editions of the standards listed below.

Copies of the following documents may be obtained from ANSI:

- a) approved ANSI standards;
- b) approved and draft international and regional standards (e.g., ISO, IEC, CEN/CENELEC, ITU-T); and
- c) approved and draft foreign standards (e.g., BSI, JIS, and DIN).

For further information, contact ANSI Customer Service Department at 212-642-4900 (phone), 212-302-1286 (fax) or via the World Wide Web at <http://www.ansi.org>.

Additional availability contact information is provided below as needed.

Table 1 lists standards bodies and their web sites.

Table 1 — Standards bodies

Abbreviation	Standards body	Web site
ANSI	American National Standards Institute	http://www.ansi.org
BSI	British Standards Institution	http://www.bsi-global.com
CEN	European Committee for Standardization	http://www.cenorm.be
CENELEC	European Committee for Electrotechnical Standardization	http://www.cenelec.org
DIN	German Institute for Standardization	http://www.din.de
IEC	International Engineering Consortium	http://www.iec.ch
IEEE	Institute of Electrical and Electronics Engineers	http://www.ieee.org
INCITS	International Committee for Information Technology Standards	http://www.incits.org
ISO	International Standards Organization	http://www.iso.ch
ITI	Information Technology Industry Council	http://www.itic.org
ITU-T	International Telecommunications Union Telecommunications Standardization Sector	http://www.itu.int
JIS	Japanese Industrial Standards Committee	http://www.jisc.org
T10	INCITS T10 Committee - SCSI storage interfaces	http://www.t10.org
T11	INCITS T11 Committee - Fibre Channel interfaces	http://www.t11.org
T13	INCITS T13 Committee - ATA storage interface	http://www.t13.org

2.2 Approved references

At the time of publication, the following referenced standards were approved.

ISO/IEC 14776-342, *SCSI-3 Controller Commands - 2 (SCC-2)*(ANSI INCITS 318-1998)

2.3 References under development

At the time of publication, the following referenced standards were still under development. For information on the current status of the documents, or regarding availability, contact the relevant standards body as indicated.

ISO/IEC 14776-xxx, *SCSI Architecture Model - 4 (SAM-4) standard* (T10/1638-D)
ISO/IEC 14776-xxx, *SCSI Primary Commands - 4 (SPC-4) standard* (T10/1731-D)
ISO/IEC 14776-352, *SCSI Media Changer Commands - 2 (SMC-2) standard* (T10/1383-D)
ISO/IEC 14776-364, *SCSI Multimedia Commands - 4 (MMC-4) standard* (T10/1545-D)
ISO/IEC 14776-372, *SCSI Enclosure Services - 2 (SES-2) standard* (T10/1559-D)

NOTE 1 - For more information on the current status of the document, contact the INCITS Secretariat at 202-737-8888 (telephone), 202-638-4922 (fax) or via Email at incits@itic.org. To obtain copies of this document, contact Global Engineering at 15 Inverness Way East Englewood, CO 80112-5704 at 800-854-7179 (telephone), 303-792-2181 (telephone), or 303-792-2192 (fax).

3 Definitions, symbols, abbreviations, keywords, and conventions

3.1 Definitions

3.1.1 additional sense code: A combination of the ADDITIONAL SENSE CODE and ADDITIONAL SENSE CODE QUALIFIER fields in the sense data. See SPC-4.

3.1.2 application client: An object that is the source of SCSI commands. See SAM-4.

3.1.3 byte: A sequence of eight contiguous bits considered as a unit.

3.1.4 cache: A temporary and often volatile data storage area outside the area accessible by application clients that may contain a subset of the data stored in the non-volatile data storage area.

3.1.5 check data: Information contained within a redundancy group (see 3.1.37) that may allow lost or destroyed XOR-protected data (see 3.1.46) to be recreated.

3.1.6 command: A request describing a unit of work to be performed by a device server. See SAM-4.

3.1.7 command descriptor block (CDB): The structure used to communicate commands from an application client to a device server. See SPC-4.

3.1.8 cyclic redundancy check (CRC): An error checking mechanism that checks data integrity by computing a polynomial algorithm based checksum. See 4.16.3.

3.1.9 data defect list (DLIST): A list of defects sent by the application client to the device server during a FORMAT UNIT command. See 4.8.

3.1.10 data-in buffer: The buffer identified by the application client to receive data from the device server during the processing of a command. See SAM-4.

3.1.11 data-out buffer: The buffer identified by the application client to supply data that is sent from the application client to the device server during the processing of a command. See SAM-4.

3.1.12 default protection information: Values placed into protection information fields if an application client does not specify specific protection information values.

3.1.13 device server: An object within a logical unit that processes SCSI tasks according to the rules of task management. See SAM-4.

3.1.14 device type: The type of device (or device model) implemented by the device server as indicated by the PERIPHERAL DEVICE TYPE field of the standard INQUIRY data. See SPC-4.

3.1.15 direct-access block device: A device that is capable of containing data stored in blocks that each have a unique logical block address.

3.1.16 domain: An I/O system consisting of a set of SCSI devices that interact with one another by means of a service delivery subsystem. See SAM-4.

3.1.17 error correcting code (ECC): An error checking mechanism that checks data integrity and enables some errors in the data to be corrected.

3.1.18 exclusive-or (XOR): A Boolean arithmetic function on two binary input values that results in an output value of 1 if one and only one of the input values is 1.

- 3.1.19 extent:** A fixed set of logical blocks occupying contiguous logical block addresses on a single logical unit.
- 3.1.20 field:** A group of one or more contiguous bits, a part of a larger structure such as a CDB (see 3.1.7) or sense data (see SPC-4).
- 3.1.21 format corrupt:** a vendor-specific condition in which the application client may not be able to perform read operations, write operations, or verify operations. See 4.6.
- 3.1.22 grown defect list (GLIST):** All defects sent by the application client to the device server. See 4.8.
- 3.1.23 hard reset:** A condition resulting from the events defined by SAM-4 in which the SCSI device performs the hard reset operations described in SAM-4, this standard, and other applicable command standards (see table 10 in 5.1).
- 3.1.24 I_T nexus loss:** A condition resulting from the events defined by SAM-4 in which the SCSI device performs the I_T nexus loss operations described in SAM-4, this standard, and other applicable command standards (see table 10 in 5.1).
- 3.1.25 logical block:** A set of data bytes accessed and referenced as a unit.
- 3.1.26 logical block address (LBA):** The value used to reference a logical block.
- 3.1.27 logical unit certification list (CLIST):** Defects detected by the device server during an optional certification process performed during the FORMAT UNIT command. See 4.8.
- 3.1.28 logical unit reset:** A condition resulting from the events defined by SAM-4 in which the logical unit performs the logical unit reset operations described in SAM-4, this standard, and other applicable command standards (see table 10 in 5.1).
- 3.1.29 media:** Plural of medium.
- 3.1.30 medium:** The material on which data is stored (e.g., a magnetic disk).
- 3.1.31 non-volatile cache:** Cache that retains data through power cycles.
- 3.1.32 non-volatile medium:** A physical storage medium that retains data written to it for subsequent read operations through power cycles (e.g., a disk within a device that stores data as magnetic field changes that do not require device power to exist).
- 3.1.33 power cycle:** Power being removed followed by power being applied to a SCSI device.
- 3.1.34 power on:** A condition resulting from the events defined by SAM-4 in which the SCSI device performs the power on operations described in SAM-4, this standard, and other applicable command standards (see table 10 in 5.1).
- 3.1.35 primary defect list (PLIST):** The list of defects that are considered permanent defects. See 4.8.
- 3.1.36 protection information:** Fields appended to each logical block that contain a cyclic redundancy check (CRC), an application tag, and a reference tag.
- 3.1.37 redundancy group:** A grouping of XOR-protected data (see 3.1.46) and associated check data (see 3.1.5) into a single type of data redundancy (see SCC-2). This standard only supports the XOR (see 3.1.18) type of redundancy.
- 3.1.38 sense data:** Data describing an error or exceptional condition that a device server delivers to an application client in association with CHECK CONDITION status. See SPC-4.

3.1.39 sense key: The contents of the SENSE KEY field in the sense data. See SPC-4.

3.1.40 status: One byte of response information sent from a device server to an application client upon completion of each command. See SAM-4.

3.1.41 storage array controller: Any combination of an initiator and application clients (see SAM-4) that originates SCSI commands, converts input LUNs to output LUNs, and converts input LBAs to output LBAs. A storage array controller organizes a group of direct-access block devices into various objects (e.g., redundancy groups and volume sets). See SCC-2.

3.1.42 user data: Data contained in logical blocks that is not protection information.

3.1.43 volatile cache: Cache that does not retain data through power cycles.

3.1.44 volatile medium: Medium that does not retain data written to it for a subsequent read operation through power cycles (e.g., a silicon memory device that loses data written to it if device power is lost).

3.1.45 XOR operation: Performing an XOR (see 3.1.18) bitwise on two identical-sized multiple-bit input values (e.g., the current value of a logical block and the new value for that logical block). In a storage array implementing a redundancy group (see 3.1.37), the XOR operation is used in error correction algorithms and may be performed by the storage array controller (see 3.1.41) or by the direct-access block devices (see 3.1.15). See 4.14.

3.1.46 XOR-protected data: Logical blocks, including user data and protection information, if any, that are part of a redundancy group (see 3.1.37).

3.2 Symbols and abbreviations

See table 1 for abbreviations of standards bodies (e.g., ISO). Additional symbols and abbreviations used in this standard include:

Abbreviation	Meaning
CDB	command descriptor block (see 3.1.7)
CRC	cyclic redundancy check (see 3.1.8)
CLIST	logical unit certification list (see 3.1.27)
DLIST	data defect list (see 3.1.9)
ECC	error correcting code (see 3.1.17)
GLIST	grown defect list (see 3.1.22)
I/O	input/output
LBA	logical block address (see 3.1.26)
LSB	least significant bit
LUN	logical unit number
MMC-4	SCSI Multimedia Commands - 4 standard
MSB	most significant bit
PLIST	primary defect list (see 3.1.35)
SAM-4	SCSI Architecture Model - 4 standard
SCSI	Small Computer System Interface family of standards
SCC-2	SCSI-3 Controller Commands - 2 standard
SES-2	SCSI Enclosure Services - 2 standard
SMC-2	SCSI Media Changer Commands - 2 standard
SPC-4	SCSI Primary Commands - 4 standard

XOR exclusive-or (see 3.1.18)

3.3 Keywords

3.3.1 expected: A keyword used to describe the behavior of the hardware or software in the design models assumed by this standard. Other hardware and software design models may also be implemented.

3.3.2 ignored: A keyword used to describe an unused bit, byte, word, field or code value. The contents or value of an ignored bit, byte, word, field or code value shall not be examined by the receiving SCSI device and may be set to any value by the transmitting SCSI device.

3.3.3 invalid: A keyword used to describe an illegal or unsupported bit, byte, word, field or code value. Receipt of an invalid bit, byte, word, field or code value shall be reported as an error.

3.3.4 mandatory: A keyword indicating an item that is required to be implemented as defined in this standard.

3.3.5 may: A keyword that indicates flexibility of choice with no implied preference (equivalent to “may or may not”).

3.3.6 may not: Keywords that indicate flexibility of choice with no implied preference (equivalent to “may or may not”).

3.3.7 need not: Keywords indicating a feature that is not required to be implemented (equivalent to “is not required to”).

3.3.8 obsolete: A keyword indicating that an item was defined in prior SCSI standards but has been removed from this standard.

3.3.9 optional: A keyword that describes features that are not required to be implemented by this standard. However, if any optional feature defined in this standard is implemented, then it shall be implemented as defined in this standard.

3.3.10 reserved: A keyword referring to bits, bytes, words, fields and code values that are set aside for future standardization. A reserved bit, byte, word or field shall be set to zero, or in accordance with a future extension to this standard. Recipients are not required to check reserved bits, bytes, words or fields for zero values. Receipt of reserved code values in defined fields shall be reported as an error.

3.3.11 restricted: A keyword referring to bits, bytes, words, and fields that are set aside for use in other SCSI standards. A restricted bit, byte, word, or field shall be treated as a reserved bit, byte, word or field for the purposes of the requirements defined in this standard.

3.3.12 shall: A keyword indicating a mandatory requirement. Designers are required to implement all such mandatory requirements to ensure interoperability with other products that conform to this standard.

3.3.13 should: A keyword indicating flexibility of choice with a strongly preferred alternative; equivalent to the phrase “it is strongly recommended.”

3.3.14 vendor-specific: Something (e.g., a bit, field, or code value) that is not defined by this standard and may be used differently in various implementations.

3.4 Conventions

Certain words and terms used in this standard have a specific meaning beyond the normal English meaning. These words and terms are defined either in this clause or in the text where they first appear.

Names of commands, status codes, sense keys, and additional sense codes are in all uppercase (e.g., REQUEST SENSE).

Names of fields and state variables are in small uppercase (e.g. NAME). When a field or state variable name contains acronyms, uppercase letters may be used for readability. Normal case is used when the contents of a field or state variable are being discussed. Fields or state variables containing only one bit are usually referred to as the NAME bit instead of the NAME field.

Normal case is used for words having the normal English meaning.

A binary number is represented in this standard by any sequence of digits comprised of only the Western-Arabic numerals 0 and 1 immediately followed by a lower-case b (e.g., 0101b). Underscores or spaces may be included between characters in binary number representations to increase readability or delineate field boundaries (e.g., 0 0101 1010b or 0_0101_1010b).

A hexadecimal number is represented in this standard by any sequence of digits comprised of only the Western-Arabic numerals 0 through 9 and/or the upper-case English letters A through F immediately followed by a lower-case h (e.g., FA23h). Underscores or spaces may be included in hexadecimal number representations to increase readability or delineate field boundaries (e.g., B FD8CFA23h or B_FD8C_FA23h).

A decimal number is represented in this standard by any sequence of digits comprised of only the Western-Arabic numerals 0 through 9 not immediately followed by a lower-case b or lower-case h (e.g., 25).

This standard uses the ISO convention for representing decimal numbers (e.g., the thousands and higher multiples are separated by a space and a comma is used as the decimal point). Table 2 shows some examples of decimal numbers represented using the ISO and American conventions.

Table 2 — ISO and American numbering convention examples

ISO	American
0,6	0.6
3,141 592 65	3.14159265
1 000	1,000
1 323 462,95	1,323,462.95

Lists sequenced by letters (e.g., a) red, b) blue, c) green) show no ordering relationship between the listed items. Lists sequenced by numbers (e.g., 1) red, 2) blue, 3) green) show an ordering relationship between the listed items.

If a conflict arises between text, tables or figures, the order of precedence to resolve the conflicts is text, then tables, and finally figures. Not all tables or figures are fully described in the text. Tables show data format and values.

Notes do not constitute any requirements for implementers.

4 Direct-access block device type model

4.1 Direct-access block device type model overview

SCSI devices that conform to this standard are referred to as direct-access block devices. This includes the category of logical units commonly referred to as rigid disks and removable rigid disks. MMC-4 is typically used by CD-ROM devices.

This standard is intended to be used in conjunction with SAM-4, SPC-4, SCC-2, SES-2, and SMC-2.

Direct-access block devices store data for later retrieval in logical blocks. Logical blocks contain user data, may contain protection information accessible to the application client, and may contain additional information not normally accessible to the application client (e.g., an ECC). The number of bytes of user data contained in each logical block is the block length. The block length is greater than or equal to one byte and should be even. Most direct-access block devices support a block length of 512 bytes and some support additional block lengths (e.g., 520 or 4096 bytes). The block length does not include the length of protection information and additional information, if any, that are associated with the logical block. The block length is the same for all logical blocks on the medium.

Each logical block is stored at a unique logical block address (LBA), which is either four bytes (i.e., a short LBA) or eight bytes (i.e., a long LBA) in length. The logical block addresses on a logical block shall begin with zero and shall be contiguous up to the last logical block on the logical unit. An application client uses commands performing write operations to store logical blocks and commands performing read operations to retrieve logical blocks. A write operation causes one or more logical blocks to be written to the medium. A read operation causes one or more logical blocks to be read from the medium. A verify operation confirms that one or more logical blocks were correctly written and are able to be read without error from the medium.

Logical blocks are stored by a process that causes localized changes or transitions within a medium. The changes made to the medium to store the logical blocks may be volatile (i.e., not retained through power cycles) or non-volatile (i.e., retained through power cycles). The medium may contain vendor specific information that is not addressable through an LBA. Such data may include defect management data and other device management information.

4.2 Media examples

4.2.1 Media examples overview

Examples of types of media used by the direct-access block device are:

- a) rotating media (see 4.2.2); and
- b) memory media (see 4.2.3).

Other types of media are possible.

4.2.2 Rotating media

The typical application of a direct-access block device is a magnetic disk device. The medium is a spinning disk with a magnetic material that allows flux changes to be induced and recorded. An actuator positions a read-write head radially across the spinning disk, allowing the device to randomly read or write the information at any radial position. Data is stored by using the write portion of the head to record flux changes and is read by using the read portion of the head to read the recorded data.

The circular path followed by the read-write head at a particular radius is called a track. The track is divided into sectors each containing blocks of stored data. If there are more than one disk spinning on a single axis and the actuator has one or more read-write heads to access the disk surfaces, the collection of tracks at a particular radius is called a cylinder.

A logical block is stored in one or more sectors, or a sector may store more than one logical block. Sectors may also contain information for accessing, synchronizing, and protecting the integrity of the logical blocks.

A rotating media-based direct-access block device is ready when the disks are rotating at the correct speed and the read-write circuitry is powered and ready to access the data, and may require a START STOP UNIT command (see 5.17) to bring the logical unit to the ready state.

Rotating media-based direct-access block device are usually non-volatile.

The defect management scheme of a disk device may not be discernible through this command set, though some aspects (see 4.8) may be accessible to the application client with the READ LONG commands and the WRITE LONG commands (see 5.14, 5.15, 5.33, and 5.34).

4.2.3 Memory media

Memory media is based on solid state random access memories (RAMs) (e.g., static RAM (SRAM), dynamic RAM (DRAM), magnetoresistive RAM (MRAM), ferroelectric RAM (FeRAM), or flash memory). Memory media-based direct-access block devices may be used for fast-access storage.

A memory media-based direct-access block device is ready after power on, and does not require a START STOP UNIT command (see 5.17) to bring the logical unit to a ready state.

These logical units may be non-mechanical, and therefore logical blocks may be accessed with similar access times regardless of their location on the medium. Memory media-based direct-access block devices may store less data than disks or tapes, and may be volatile.

The defect management scheme (e.g., ECC bytes) (see 4.8) may be accessible to the application client with the READ LONG commands and the WRITE LONG commands (see 5.14, 5.15, 5.33, and 5.34).

Memory media may be volatile (e.g., SRAM or DRAM) or non-volatile (e.g., SRAM or DRAM with battery backup, MRAM, FeRAM, or flash memory).

4.3 Removable medium

4.3.1 Removable medium overview

The medium may be removable or non-removable. The removable medium may be contained within a cartridge or jacket to prevent damage to the recording surfaces.

A removable medium has an attribute of being mounted or unmounted on a suitable transport mechanism in a direct-access block device. A removable medium is mounted when the direct-access block device is capable of performing write, read, and verify operations to the medium. A removable medium is unmounted at any other time (e.g., during loading, unloading, or storage).

An application client may check whether a removable medium is mounted by issuing a TEST UNIT READY command (see SPC-4). A direct-access block device containing a removable medium may not be accessible for write, read, and verify operations until it receives a START STOP UNIT command (see 5.17).

If the direct-access block device implements cache, either volatile or non-volatile, it ensures that all logical blocks of the medium contain the most recent user data and protection information, if any, prior to permitting unmounting of the removable medium.

The PREVENT ALLOW MEDIUM REMOVAL command (see SPC-4) allows an application client to restrict the unmounting of the removable medium. This is useful in maintaining system integrity.

If the application client issues a START STOP UNIT command to eject the removable medium, and the direct-access block device is prevented from unmounting by the PREVENT ALLOW MEDIUM REMOVAL command, the START STOP UNIT command is rejected by the device server.

4.3.2 Removable medium with an attached media changer

When a direct-access block device is served by an attached media changer, control over a medium transport element may be accomplished using media changer commands (see SMC-2) sent to the direct-access block device type logical unit.

The direct-access block device indicates its ability to support these commands by setting the MCHNGR bit to one in its standard INQUIRY data (see SPC-4). A MCHNGR bit set to one indicates that the MOVE MEDIUM

ATTACHED and READ ELEMENT STATUS ATTACHED commands (see SMC-2) are supported. The logical unit may require a MODE MEDIUM ATTACHED command (see SMC-2) to become ready.

4.4 Logical blocks

Logical blocks are stored on the medium along with additional information that the device server uses to manage the storage and retrieval. The format of the additional information is defined by other standards or is vendor-specific and is hidden from the application client during normal read, write, and verify operations. This additional information may be used to identify the physical location of the blocks of data, the address of the logical block, and to provide protection against the loss of user data and protection information, if any (e.g., by containing ECC bytes).

The first logical block address is zero. The last logical block address is [n-1], where [n] is the number of logical blocks on the medium accessible by the application client. A READ CAPACITY command should be used to determine the value of [n-1].

Logical block addresses are no larger than 8 bytes. Some commands support only 4 byte (i.e., short) LOGICAL BLOCK ADDRESS fields (e.g., READ CAPACITY (10), READ (10), and WRITE (10)). The READ CAPACITY (10) command returns a capacity of FFFFFFFFh if the capacity exceeds that accessible with short LBAs, indicating that:

- a) the application client should enable descriptor format sense data (see SPC-4) in the Control mode page (see SPC-4) and in any REQUEST SENSE commands (see SPC-4) it sends; and
- b) the application client should use commands with 8-byte LOGICAL BLOCK ADDRESS fields (e.g., READ CAPACITY (16), READ (16), and WRITE (16)).

NOTE 2 - If a command with a 4-byte LOGICAL BLOCK ADDRESS field accesses logical blocks beyond logical block address FFFFFFFFh and fixed format sense data is used, there is no field in the sense data large enough to report the logical block address of an error (see 4.13).

If a command is received that references or attempts to access a logical block not within the capacity of the medium, the device server terminates the command with CHECK CONDITION status with the sense key set to ILLEGAL REQUEST and the additional sense code set to LOGICAL BLOCK ADDRESS OUT OF RANGE. The command may be terminated before processing or after the device server has transferred some or all of the data.

The number of bytes of user data contained in a logical block is the block length. The parameter data returned by the READ CAPACITY command (see 5.10) describes the block length that is used on the medium. The mode parameter block descriptor (see 6.3.2) is used to change the block length in direct-access block devices that support changeable block lengths. The block length does not include the length of protection information and additional information, if any.

The location of a logical block on the medium is not required to have a relationship to the location of any other logical block. However, in a typical direct-access block device, the time to access a logical block at address [x+1] after accessing logical block [x] is often less than the time to access some other logical block. The time to access the logical block at address [x] and then the logical block at address [x+1] need not be less than time to access [x] and then [x+100]. The READ CAPACITY command issued with a PMI bit set to one may be useful in determining where longer access times occur.

4.5 Ready state

A direct-access block device is ready when the device server is capable of processing medium access commands (i.e., commands that perform read operations, write operations, or verify operations).

A direct-access block device using removable media is not ready until a volume is mounted and other conditions are met (see 4.2). A direct-access block device that is not ready shall terminate medium access commands with CHECK CONDITION status with the sense key set to NOT READY and the appropriate additional sense code for the condition.

Some direct-access block devices may be switched from being ready to being not ready by using the START STOP UNIT command (see 5.17). An application client may need to issue a START STOP UNIT command with a START bit set to one to make a direct-access block device ready.

4.6 Initialization

Direct-access block devices may require initialization prior to write, read, and verify operations. This initialization is performed by a FORMAT UNIT command (see 5.2). Parameters related to the format (e.g., block size) may be set with the MODE SELECT command prior to the format operation. Some direct-access block devices are initialized by means not specified in this standard. The time when the initialization occurs is vendor-specific.

Direct-access block devices using a non-volatile medium may save the parameters and only need to be initialized once. However, some mode parameters may need to be initialized after each logical unit reset. A catastrophic failure of the direct-access block device may require the FORMAT UNIT command to be issued.

Direct-access block devices that use a volatile medium may need to be initialized after each logical unit reset prior to the processing of write, read, or verify operations. Mode parameters may also need initialization after logical unit resets.

NOTE 3 - Mode parameter block descriptors read with the MODE SENSE command before a FORMAT UNIT completes return information that may not reflect the true state of the medium.

A direct-access block device may become format corrupt after processing a MODE SELECT command that changes parameters related to the medium format. During this time, the device server may terminate medium access commands with CHECK CONDITION status with the sense key set to NOT READY and the appropriate additional sense code for the condition.

Any time the parameter data returned by the READ CAPACITY (10) command (see 5.10) or the READ CAPACITY (16) command (see 5.11) changes (e.g., when a FORMAT UNIT command or a MODE SELECT command completes changing the number of blocks, block size, protection information, or reference tag ownership values, or when a vendor-specific mechanism causes a change), the device server should establish a unit attention condition for the initiator port associated with each L_T nexus except the L_T nexus on which the command causing the change was received with an additional sense code of CAPACITY DATA HAS CHANGED.

NOTE 4 - Logical units compliant with previous versions of this standard did not establish a unit attention condition.

4.7 Write protection

Write protection prevents the alteration of the medium by commands issued to the device server. Write protection is usually controlled by the user of the medium through manual intervention (e.g., mechanical lock) or may result from hardware controls (e.g., tabs on the media housing) or software write protection. All sources of write protection are independent. When present, any write protection shall cause otherwise valid commands that request alteration of the medium to be rejected with CHECK CONDITION status with the sense key set to DATA PROTECT. Only when all write protections are disabled shall the device server process commands that request alteration of the medium.

Hardware write protection results when a physical attribute of the drive or medium is changed to specify that writing shall be prohibited. Changing the state of the hardware write protection requires physical intervention, either with the drive or the medium. If allowed by the drive, changing the hardware write protection while the medium is mounted results in vendor-specific behavior that may include the writing of previously buffered data (e.g., data in cache).

Software write protection results when the device server is marked as write protected by the application client using the SWP bit in the Control mode page (see SPC-4). Software write protection is optional. Changing the state of software write protection shall not prevent previously accepted data (e.g., data in cache) from being written to the media.

The device server reports the status of write protection in the device server and on the medium with the DEVICE-SPECIFIC PARAMETER field in the mode parameter header (see 6.3.1).

4.8 Medium defects

Any medium has the potential for defects that cause data to be lost. Therefore, each logical block may contain additional information that allows the detection of changes to the user data and protection information, if any, caused by defects in the medium or other phenomena, and may also allow the data to be reconstructed following the detection of such a change (e.g., ECC bytes). Some direct-access block devices allow the application client to examine and modify the additional information by using the READ LONG commands and the WRITE LONG commands (see 5.14, 5.15, 5.33, and 5.34). The application client may use the WRITE LONG commands to induce a defect to test the defect detection logic of the direct-access block device or to emulate an unrecoverable logical block when generating a mirror copy.

Defects may also be detected and managed during processing of the FORMAT UNIT command (see 5.2). The FORMAT UNIT command defines four sources of defect information: the PLIST, CLIST, DLIST, and GLIST. These defects may be reassigned or avoided during the initialization process so that they do not affect any logical blocks. The sources of defect location information (i.e., defects) are defined as follows:

- a) Primary defect list (PLIST). This is the list of defects, which may be supplied by the original manufacturer of the device or medium, that are considered permanent defects. The PLIST is located outside of the application client accessible logical block space. The PLIST is accessible by the device server for reference during the format operation, but it is not accessible by the application client except through the READ DEFECT DATA commands (see 5.10 and 5.13). Once created, the original PLIST shall not change;
- b) Logical unit certification list (CLIST). This list includes defects detected by the device server during an optional certification process performed during the FORMAT UNIT command. This list shall be added to the GLIST;
- c) Data defect list (DLIST). This list of defects may be supplied by the application client to the device server during the FORMAT UNIT command. This list shall be added to the GLIST; and
- d) Grown defect list (GLIST). The GLIST includes all defects sent by the application client (i.e., the DLIST) or detected by the device server (i.e., the CLIST). The GLIST does not include the PLIST. If the CMLST bit is set to zero, the GLIST shall include DLISTS provided to the device server during the previous and the current FORMAT UNIT commands. The GLIST shall also include:
 - A) defects detected by the format operation during medium certification;
 - B) defects previously identified with a REASSIGN BLOCKS command (see 5.16); and
 - C) defects previously detected by the device server and automatically reallocated.

The direct-access block device may automatically reassign defects if allowed by the Read-Write Error Recovery mode page (see 6.3.5).

Defects may also occur after initialization. The application client issues a REASSIGN BLOCKS command (see 5.16) to request that the specified logical block address be reassigned to a different part of the medium. This operation may be repeated if a new defect appears at a later time. The total number of defects that may be handled in this manner is vendor-specific.

Defect management on direct-access block devices is vendor-specific. Direct-access block devices not using a removable medium may optimize the defect management for capacity or performance or both. Some direct-access block devices that use a removable medium do not support defect management or use defect management that does not impede the ability to interchange the medium.

4.9 Write failures

If one or more commands performing write operations are in the task set and are being processed when power is lost (e.g., resulting in a vendor-specific command timeout by the application client) or a medium error or hardware error occurs (e.g., because a removable medium was incorrectly unmounted), the data in the logical blocks being written by those commands is indeterminate. When accessed by a command performing a read or verify operation (e.g., after power on or after the removable medium is mounted), the device server may return old data, new data, or vendor-specific data in those logical blocks.

Before reading logical blocks which encountered such a failure, an application client should reissue any commands performing write operations that were outstanding.

4.10 Caches

Direct-access block devices may implement caches. A cache is an area of temporary storage in the direct-access block device with a fast access time that is used to enhance performance. Cache exists separately from the medium and is not directly accessible by the application client. Use of cache for write or read operations may reduce the access time to a logical block and increase the overall data throughput.

Cache stores user data and protection information, if any.

Cache may be volatile or non-volatile. Volatile caches do not retain data through power cycles. Non-volatile cache memories retain data through power cycles. There may be a limit on the amount of time a non-volatile cache is able to retain data without power.

During read operations, the device server uses the cache to store logical blocks that the application client may request at some future time. The algorithm used to manage the cache is not part of this standard. However, parameters are provided to advise the device server about future requests, or to restrict the use of cache for a particular request.

During write operations, the device server uses the cache to store data that is to be written to the medium at a later time. This is called write-back caching. The command may complete prior to logical blocks being written to the medium. As a result of using a write-back caching there is a period of time when the data may be lost if power to the SCSI target device is lost and a volatile cache is being used or a hardware failure occurs. There is also the possibility of an error occurring during the subsequent write operation. If an error occurred during the write operation, it may be reported as a deferred error on a later command. The application client may request that write-back caching be disabled with the Caching mode page (see 6.3.4) to prevent detected write errors from being reported as deferred errors. Even with write-back caching disabled, undetected write errors may occur. The VERIFY commands and the WRITE AND VERIFY commands may be used to detect those errors.

When the cache becomes full of logical blocks, new logical blocks may replace those currently in the cache. The disable page out (DPO) bit in the CDB of commands performing write, read, or verify operations allows the application client to influence the replacement of logical blocks in the cache. For write operations, setting the DPO bit to one specifies that the device server should not replace existing logical blocks in the cache with the new logical blocks being written. For read and verify operations, setting the DPO bit to one specifies that the device server should not replace logical blocks in the cache with the logical blocks that are being read.

NOTE 5 - This does not mean that stale data is allowed in the cache. If a write operation accesses the same LBA as a logical block in the cache, the logical block in the cache is updated with the new write data.

Application clients may use the force unit access (FUA) bit in the CDB of commands performing write or read operations to specify that the device server shall access the medium. For a write operation, setting the FUA bit to one causes the device server to complete the data write to the medium before completing the command. For a read operation, setting the FUA bit to one causes the device server to retrieve the logical blocks from the medium rather than from the cache.

When the DPO and FUA bits are both set to one, write and read operations effectively bypass the cache.

Application clients may use the force unit access non-volatile cache (FUA_NV) bit in the CDB of commands performing write or read operations to specify that the device server may access a non-volatile cache, if any, rather than the medium, if the FUA bit is set to zero. For a write operation, an FUA_NV bit set to one with the FUA bit set to zero allows the device server to complete the data write to non-volatile cache rather than the medium before completing the command. For a read operation, an FUA_NV bit set to one with the FUA bit set to zero allows the device server to retrieve the logical blocks from the non-volatile cache rather than the medium.

When a VERIFY command or a WRITE AND VERIFY command is processed, both a force unit access and a synchronize cache operation are implied, since the logical blocks are being verified as being stored on the medium. The DPO bit is defined in the VERIFY command since the VERIFY command may cause the replacement of logical blocks in the cache.

Commands may be implemented by the device server that allow the application client to control other behavior of the cache:

- a) the PRE-FETCH commands (see 5.3 and 5.4) cause a set of logical blocks requested by the application client to be read into cache for possible future access. The logical blocks fetched are subject to later replacement;
- b) the SYNCHRONIZE CACHE commands (see 5.18 and 5.19) force any write data in cache in the requested set of logical blocks to be written to the medium. These commands may be used to ensure that the data is written and any detected errors reported;
- c) the Caching mode page (see 6.3.4), writable by the MODE SELECT commands, allows control of cache behavior.

4.11 Implicit HEAD OF QUEUE command processing

Each of the following commands defined by this standard may be processed by the task manager as if it has a task attribute of HEAD OF QUEUE (see SAM-4) if it is received with a SIMPLE task attribute, an ORDERED task attribute, or no task attribute:

- a) the READ CAPACITY (10) command; and
- b) the READ CAPACITY (16) command.

See SPC-4 for additional commands subject to implicit HEAD OF QUEUE command processing.

Application clients should not send a command with the ORDERED task attribute if it may be processed as if it has a task attribute of HEAD OF QUEUE, because whether the ORDERED task attribute is honored is vendor-specific.

4.12 Reservations

Reservation restrictions are placed on commands as a result of access qualifiers associated with the type of reservation. See SPC-4 for a description of reservations. The details of commands that are allowed under what types of reservations are described in table 3.

Commands from I_T nexuses holding a reservation should complete normally. Table 3 specifies the behavior of commands from registered I_T nexuses when a registrants only or all registrants type persistent reservation is present.

For each command, this standard or SPC-4 defines the conditions that result in RESERVATION CONFLICT.

Table 3 — SBC-2 commands that are allowed in the presence of various reservations

Command	Addressed logical unit has this type of persistent reservation held by another I_T nexus				
	From any I_T nexus		From registered I_T nexus (RR all types)	From I_T nexus not registered	
	Write Exclusive	Exclusive Access		Write Exclusive - RR	Exclusive Access - RR
FORMAT UNIT	Conflict	Conflict	Allowed	Conflict	Conflict
PRE-FETCH (10)/(16)	Allowed	Conflict	Allowed	Allowed	Conflict
READ (6)/(10)/(12)/(16)/(32)	Allowed	Conflict	Allowed	Allowed	Conflict
READ CAPACITY (10)/(16)	Allowed	Allowed	Allowed	Allowed	Allowed
READ DEFECT DATA (10)/(12)	Conflict	Conflict	Allowed	Conflict	Conflict
READ LONG (10)/(16)	Conflict	Conflict	Allowed	Conflict	Conflict
REASSIGN BLOCKS	Conflict	Conflict	Allowed	Conflict	Conflict
START STOP UNIT with START bit set to one and POWER CONDITION field set to 0h	Allowed	Allowed	Allowed	Allowed	Allowed
START STOP UNIT with START bit set to zero or POWER CONDITION field set to a value other than 0h	Conflict	Conflict	Allowed	Conflict	Conflict
SYNCHRONIZE CACHE (10)/(16)	Conflict	Conflict	Allowed	Conflict	Conflict
VERIFY (10)/(12)/(16)/(32)	Allowed	Conflict	Allowed	Allowed	Conflict
WRITE (6)/(10)/(12)/(16)/(32)	Conflict	Conflict	Allowed	Conflict	Conflict
WRITE AND VERIFY (10)/(12)/(16)/(32)	Conflict	Conflict	Allowed	Conflict	Conflict
WRITE LONG (10)/(16)	Conflict	Conflict	Allowed	Conflict	Conflict
WRITE SAME (10)/(16)/(32)	Conflict	Conflict	Allowed	Conflict	Conflict
XDREAD (10)/(32)	Allowed	Conflict	Allowed	Allowed	Conflict
XDWRITE (10)/(32)	Conflict	Conflict	Allowed	Conflict	Conflict
XDWRITEREAD (10)/(32)	Conflict	Conflict	Allowed	Conflict	Conflict
XPWRITE (10)/(32)	Conflict	Conflict	Allowed	Conflict	Conflict

Key: RR = Registrants Only or All Registrants
Allowed: Commands received from I_T nexuses not holding the reservation or from I_T nexuses not registered when a registrants only or all registrants type persistent reservation is present should complete normally.
Conflict: Commands received from I_T nexuses not holding the reservation or from I_T nexuses not registered when a registrants only or all registrants type persistent reservation is present shall not be performed and the device server shall terminate the command with RESERVATION CONFLICT status.

4.13 Error reporting

4.13.1 Error reporting overview

If any of the conditions listed in table 4 occur during the processing of a command, the command shall be terminated with CHECK CONDITION status with the sense key set to the specified value and the additional sense code set to the appropriate value for the condition. Some errors may occur after the completion status has already been reported. For such errors, SPC-4 defines a deferred error reporting mechanism. Table 4 lists some error conditions and the applicable sense keys. The list does not provide an exhaustive enumeration of all conditions that may cause CHECK CONDITION status.

Table 4 — Example error conditions

Condition	Sense key
Invalid LBA	ILLEGAL REQUEST
Unsupported option requested	ILLEGAL REQUEST
Logical unit reset, I_T nexus loss, or medium change since last command from this application client	UNIT ATTENTION
Self diagnostic failed	HARDWARE ERROR
Unrecovered read error	MEDIUM ERROR or HARDWARE ERROR
Recovered read error	RECOVERED ERROR
Over-run or other error that might be resolved by repeating the command	ABORTED COMMAND
Attempt to write on write-protected medium	DATA PROTECT

Direct-access block devices compliant with this standard shall support both the fixed and descriptor formats of sense data (see SPC-4). If fixed format sense data is used but the values to be placed in the sense data INFORMATION field or COMMAND-SPECIFIC INFORMATION field are too large for the fixed format sense data (e.g., an 8-byte LBA), the VALID bit shall be set to zero.

Table 5 summarizes use of the sense data fields.

Table 5 — Sense data field usage for direct-access block devices

Field	Usage	Reference
VALID bit and INFORMATION field	READ LONG commands	5.14 and 5.15
	REASSIGN BLOCKS command	5.16
	WRITE LONG commands	5.33 and 5.34
	Any command that accesses the medium, based on the Read-Write Error Recovery mode page	6.3.5
COMMAND-SPECIFIC INFORMATION field	EXTENDED COPY command	SPC-4
	REASSIGN BLOCKS command	5.16
ILI bit	READ LONG commands	5.14 and 5.15
	WRITE LONG commands	5.33 and 5.34

When a command attempts to access or reference an invalid LBA, the first invalid LBA shall be returned in the INFORMATION field of the sense data (see SPC-4).

When a recovered read error is reported, the INFORMATION field of the sense data shall contain the LBA of the last recovered error during the transfer.

When an unrecovered read error is reported, the INFORMATION field of the sense data shall contain the LBA of the unrecovered logical block.

4.13.2 Block commands sense data descriptor

Table 6 defines the block commands sense data descriptor used in descriptor format sense data for direct-access block devices.

Table 6 — Block commands sense data descriptor format

Byte\Bit	7	6	5	4	3	2	1	0
0	DESCRIPTOR TYPE (05h)							
1	ADDITIONAL LENGTH (02h)							
2	Reserved							
3	Reserved		ILI	Reserved				

The DESCRIPTOR TYPE field (see SPC-4) shall be set to 05h.

The ADDITIONAL LENGTH field (see SPC-4) shall be set to 02h.

The INCORRECT LENGTH INDICATION (ILI) bit indicates that the requested data length in a READ LONG command or WRITE LONG command did not match the length of the logical block.

4.14 Model for XOR commands

4.14.1 Model for XOR commands overview

In storage arrays, a storage array controller (see 3.1.41) organizes a group of direct-access block devices into objects. The type of object supported by this model is the redundancy group (see 3.1.37), where some of the logical blocks on the direct-access block devices are used for XOR-protected data (see 3.1.46) and some of the logical blocks are used for check data (see 3.1.5). The check data is generated by performing a cumulative XOR (see 3.1.18) operation of the XOR-protected data. The XOR operation may be performed by the storage array controller or by the direct-access block devices.

A direct-access block device containing XOR-protected data is called a data disk. A direct-access block device containing check data is called a parity disk.

Performing the XOR operation in the direct-access block devices may result in a reduced number of data transfers across the service delivery subsystem. For example, when the XOR operation is done within the storage array controller, four commands are needed for a typical update write sequence:

- a) a command performing a read operation from the data disk;
- b) a command performing a write operation to the data disk;
- c) a command performing a read operation from the parity disk; and
- d) a command performing a write operation to the parity disk.

The storage array controller also does two internal XOR operations in this sequence.

In contrast, during storage array controller supervised XOR operations (see 4.14.2) only three commands are needed:

- a) a command performing a write operation to the data disk;
- b) a command performing a read operation from the data disk; and
- c) a command performing a write operation to the parity disk.

4.14.2 Storage array controller supervised XOR operations

4.14.2.1 Storage array controller supervised XOR operations overview

A storage array controller supervises three basic operations that require XOR functionality:

- a) update write operation (see 4.14.2.2);
- b) regenerate operation (see 4.14.2.3); and
- c) rebuild operation (see 4.14.2.4).

Command sequences for each of these operations use the device servers in the direct-access block devices to perform the necessary XOR functions.

Three XOR commands are needed to implement storage array controller supervised XOR operations: XDREAD commands (see 5.38 and 5.39), XDWRITE commands (see 5.40 and 5.41), and XPWRITE commands (see 5.44 and 5.45). An XDWRITEREAD command (see 5.42 and 5.43) may be used in place of a sequence of an XDWRITE command followed by an XDREAD command. The storage array controller also uses READ commands and WRITE commands for certain operations.

4.14.2.2 Update write operation

The update write operation writes new XOR-protected data to a data disk and updates the check data on the parity disk. The sequence is:

- 1) An XDWRITE command is sent to the data disk. This transfers new XOR-protected data to the data disk. The device server reads the old XOR-protected data, performs an XOR operation using the old XOR-protected data and the received XOR-protected data, retains the intermediate XOR result, and writes the received XOR-protected data to the medium;
- 2) An XDREAD command is sent to the data disk. This command transfers the intermediate XOR data to the storage array controller; and
- 3) An XPWRITE command is sent to the parity disk. This transfers the intermediate XOR data (i.e., XOR data received in a previous XDREAD command) to the parity disk. The device server reads the old check data, performs an XOR operation using the old check data and the intermediate XOR data, and writes the result (i.e., the new check data) to the medium.

In place of steps 1) and 2), a single XDWRITEREAD command may be sent.

4.14.2.3 Regenerate operation

The regenerate operation is used to recreate one or more logical blocks that have an error. This is accomplished by reading the associated logical block from each of the other direct-access block devices within the redundancy group and performing an XOR operation with each of these logical blocks. The last XOR result is the data that should have been present on the unreadable direct-access block device. The number of steps is dependent on the number of direct-access block devices in the redundancy group, but the sequence is as follows:

- 1) A READ command is sent to the first direct-access block device. This transfers the data from the direct-access block device to the storage array controller;
- 2) An XDWRITE command with the DISABLE WRITE bit set to one is sent to the next direct-access block device, transferring the data from the previous read operation to the next direct-access block device. The direct-access block device reads its data, performs an XOR operation on the received data and its data, and retains the intermediate XOR result;
- 3) An XDREAD command is sent to the same direct-access block device as in step 2). This transfers the intermediate XOR data from the device to the storage array controller; and
- 4) Steps 2) and 3) are repeated until all direct-access block devices in the redundancy group except the failed device have been accessed.

The intermediate XOR data returned by the last XDREAD command is the regenerated data for the failed device.

In place of steps 2) and 3), a single XDWRITEREAD command with the DISABLE WRITE bit set to one may be used.

4.14.2.4 Rebuild operation

The rebuild operation is similar to the regenerate operation, except that the last XOR result is written to the replacement device. This function is used when a failed device is replaced and the storage array controller is writing the rebuilt data to the replacement device. The number of steps is dependent on the number of direct-access block devices in the redundancy group, but the sequence is as follows:

- 1) A READ command is sent to the first direct-access block device. This transfers the data from the direct-access block device to the storage array controller;
- 2) An XDWRITE command with the DISABLE WRITE bit set to one is sent to the next direct-access block device, transferring the data from the previous read operation to the next direct-access block device. The device server reads its data, performs an XOR operation using the received data and its data, and retains the intermediate XOR result;
- 3) An XDREAD command is sent to the same direct-access block device as in step 2). This transfers the intermediate XOR data from the device to the storage array controller;
- 4) Steps 2) and 3) are repeated until all direct-access block devices in the redundancy group except the replacement device have been accessed. The intermediate XOR data returned by the last XDREAD command is the regenerated data for the replacement device; and
- 5) A WRITE command is sent to the replacement device. This transfers the regenerated data from step 4 to the replacement device. The replacement device writes the regenerated data to the medium.

In place of steps 2) and 3), a single XDWRITEREAD command with the DISABLE WRITE bit set to one may be used.

4.14.3 Array subsystem considerations

4.14.3.1 Array subsystem considerations overview

This subclause lists considerations that apply to any array subsystem, but describes how use of the XOR commands may affect handling of those situations.

4.14.3.2 Buffer full status handling

When the storage array controller sends an XDWRITE command to a device, the device retains the resulting XOR data until the storage array controller issues a matching XDREAD command to retrieve the data (see 4.14.4). Depending on the size of the device's buffer and the size of the XOR data, this may consume all of the device's internal buffer space. When all of the device's internal buffer space is allocated for XOR data, it may not be able to accept new medium access commands other than valid XDREAD commands and it may not be able to begin processing of commands that are already in the task set.

When the device server is not able to accept a new command because there is not enough space in the buffer, the device server shall terminate that command with CHECK CONDITION status with the sense key set to ILLEGAL REQUEST and the additional sense code set to BUFFER FULL.

When a storage array controller receives this status, it may issue any matching XDREAD commands needed to satisfy any previous XDWRITE commands. This results in buffer space being freed for use by other commands. If it has no XDREAD commands to send, the storage array controller may assume the buffer space has been allocated to another initiator device. The storage array controller may retry the command in the same manner that it would retry a command that returns TASK SET FULL status, including not retrying the command too frequently.

The bidirectional XDWRITEREAD command avoids the buffer full condition, since the device server controls when it accepts more write data and provides read data.

4.14.3.3 Access to an inconsistent stripe

A stripe is a set of corresponding extents (see 3.1.19) from two or more direct-access block devices.

When the storage array controller issues an update write to a data disk, the data in the data disk has been updated when successful status is returned for the command. Until the parity disk has been updated, however, the associated stripe in the redundancy group is not consistent (i.e., performing an XOR operation on the XOR-protected data does not produce the check data).

The storage array controller shall keep track of this window of inconsistency and ensure that a regenerate or rebuild operation for any data extent within the stripe is not attempted until after the parity disk has been updated, making the stripe consistent again. For multi-initiator systems, tracking the updates may be more complex because each storage array controller needs to ensure that a second storage array controller is not writing to a stripe that the first storage array controller is regenerating or rebuilding. The coordination between storage array controllers is system specific and is beyond the scope of this standard.

If any of the XOR commands end with CHECK CONDITION status and an unrecovered error is indicated, an inconsistent stripe may result. It is the storage array controller's responsibility to identify the failing device, the identify the scope of the failure, then limit access to the inconsistent stripe. The recovery procedures that the storage array controller implements are outside the scope of this standard.

4.14.4 XOR data retention requirements

The device server shall retain XOR data resulting from an XDWRITE command awaiting retrieval by a matching XDREAD command until one of the following events occurs:

- a) a matching XDREAD command;
- b) logical unit reset;
- c) I_T nexus loss associated with the I_T nexus that sent the XDWRITE command;
- d) processing any of the following task management functions (see SAM-4):
 - A) CLEAR TASK SET;
 - B) ABORT TASK specifying the I_T_L_Q nexus of an XDREAD command retrieving that XOR data;
 - or
 - C) ABORT TASK SET.

If the XOR data is lost and the application client still wants to perform the XOR operation, it is required to resent the XDWRITE command after one of those events.

4.15 START STOP UNIT and power conditions

4.15.1 START STOP UNIT and power conditions overview

The START STOP UNIT command (see 5.17) allows an application client to control the power condition of a logical unit. This method includes specifying that the logical unit transition to a power condition.

In addition to the START STOP UNIT command, the power condition of a logical unit may be controlled by the Power Condition mode page (see SPC-4). If both the START STOP UNIT command and the Power Condition mode page methods are being used to control the power condition of the same logical unit, then the power condition specified by any START STOP UNIT command shall override the Power Condition mode page's power control.

There shall be no notification to the application client that a logical unit has transitioned from one power condition to another. An application client may determine the current power condition of a logical unit by issuing a REQUEST SENSE command (see SPC-4). The device server returns parameter data with the sense key set to NO SENSE and the additional sense code set to one of the following:

- a) LOW POWER CONDITION ON if the reason for entry into the standby power condition or idle power condition is unknown;
- b) IDLE CONDITION ACTIVATED BY TIMER if the logical unit entered the idle power condition due to the idle condition timer (see SPC-4);
- c) STANDBY CONDITION ACTIVATED BY TIMER if the logical unit entered the standby power condition due to the standby condition timer (see SPC-4);
- d) IDLE CONDITION ACTIVATED BY COMMAND if the logical unit entered the idle power condition due to a START STOP UNIT command; or
- e) STANDBY CONDITION ACTIVATED BY COMMAND if the logical unit entered the standby power condition due to a START STOP UNIT command.

No power condition shall affect the supply of any power required for proper operation of the service delivery subsystem.

4.15.2 START STOP UNIT and power conditions state machine

4.15.2.1 START STOP UNIT and power conditions state machine overview

The SSU_PC (start stop unit power condition) state machine for logical units implementing the START STOP UNIT command describes the logical unit power states and transitions resulting from settings by the START STOP UNIT command and settings in the Power Condition mode page (see SPC-4).

The SSU_PC states are as follows:

- a) SSU_PC0:Powered_on (see 4.15.2.2) (initial state);
- b) SSU_PC1:Active (see 4.15.2.3);
- c) SSU_PC2:Idle (see 4.15.2.4);
- d) SSU_PC3:Standby (see 4.15.2.5); and
- e) SSU_PC4:Stopped (see 4.15.2.6).

The SSU_PC state machine shall start in the SSU_PC0:Powered_on state after power on.

NOTE 6 - The SSU_PC state machine is an enhanced version of the Power Condition state machine described in SPC-4.

Figure 2 describes the SSU_PC state machine.

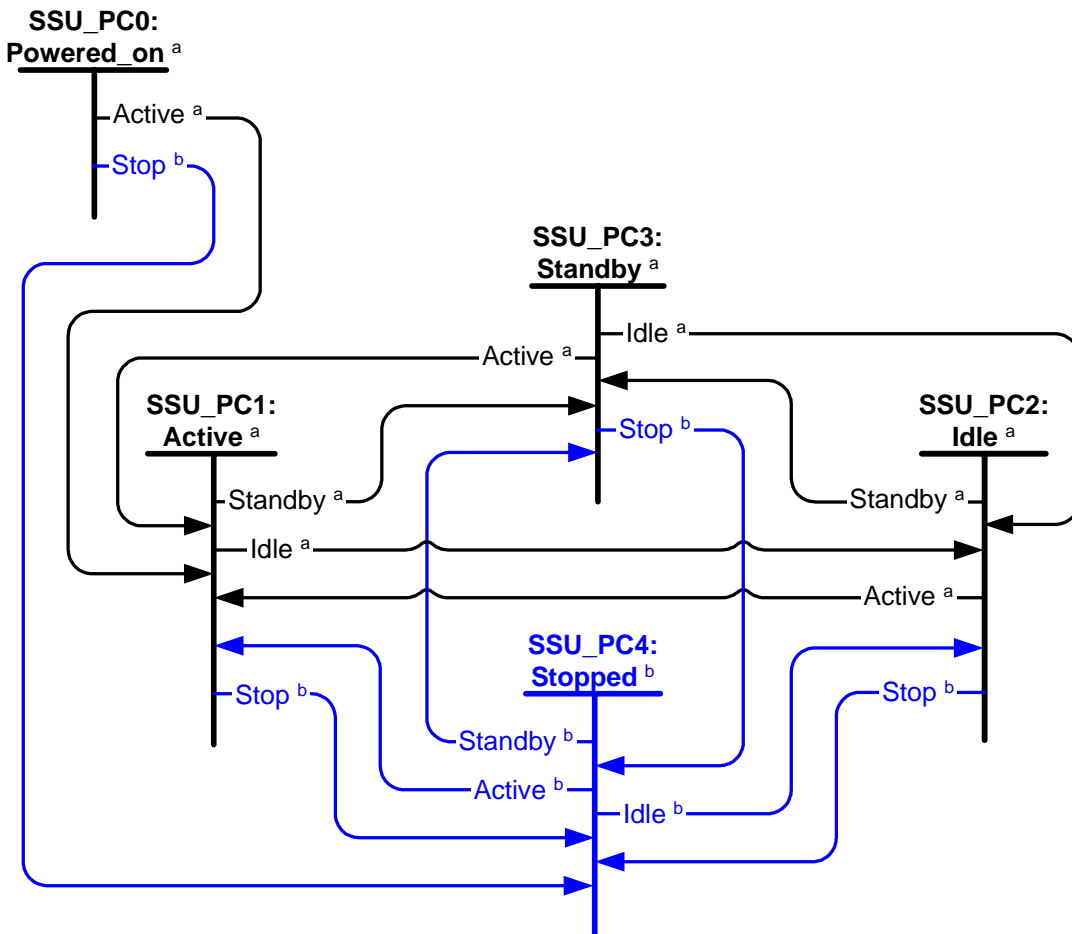

Notes:

^aThis state or transition is also described in SPC-3, but may have additional characteristics unique to this standard (e.g., a transition to or from a state described in this standard).

^bThis state or transition is described in this standard.

Figure 2 — Power condition state machine for logical units implementing the START STOP UNIT command

4.15.2.2 SSU_PC0:Powered_on state**4.15.2.2.1 SSU_PC0:Powered_on state description**

The logical unit shall enter this state upon power on. This state consumes zero time.

4.15.2.2.2 Transition SSU_PC0:Powered_on to SSU_PC1:Active

This transition shall occur if the logical unit has been configured to transition to the SSU_PC1:Active state.

4.15.2.2.3 Transition SSU_PC0:Powered_on to SSU_PC4:Stopped

This transition shall occur if the logical unit has been configured to transition to the SSU_PC4:Stopped state.

4.15.2.3 SSU_PC1:Active state**4.15.2.3.1 SSU_PC1:Active state description**

While in this state, if power on initialization is not complete, then the logical unit completes its power on initialization.

While in this state, after power on initialization is complete, then:

- a) the logical unit is in the active power condition (see SPC-4);
- b) if the idle condition timer is active (see SPC-4) and not disabled (see 5.17), then the idle condition timer is running; and
- c) if the standby condition timer is active (see SPC-4) and not disabled (see 5.17), then the standby condition timer is running.

4.15.2.3.2 Transition SSU_PC1:Active to SSU_PC2:Idle

This transition shall occur after:

- a) the device server receives a START STOP UNIT command with the POWER CONDITION field set to IDLE;
- b) the device server receives a START STOP UNIT command with the POWER CONDITION field set to FORCE_IDLE_0; or
- c) the idle condition timer is active (see SPC-4), enabled (see 5.17), and zero.

4.15.2.3.3 Transition SSU_PC1:Active to SSU_PC3:Standby

This transition shall occur after:

- a) the device server receives a START STOP UNIT command with the POWER CONDITION field set to STANDBY;
- b) the device server receives a START STOP UNIT command with the POWER CONDITION field set to FORCE_STANDBY_0; or
- c) the standby condition timer is active (see SPC-4), enabled (see 5.17), and zero.

4.15.2.3.4 Transition SSU_PC1:Active to SSU_PC4:Stopped

This transition shall occur after the device server receives a START STOP UNIT command with the START bit set to zero and the POWER CONDITION field set to START_VALID.

4.15.2.4 SSU_PC2:Idle state**4.15.2.4.1 SSU_PC2:Idle state description**

While in this state:

- a) the logical unit is in the idle power condition (see SPC-4); and
- b) if the standby condition timer is active (see SPC-4) and not disabled (see 5.17), then the standby condition timer is running.

4.15.2.4.2 Transition SSU_PC2:Idle to SSU_PC1:Active

This transition shall occur after:

- a) the device server receives a START STOP UNIT command with the START bit set to one;
- b) the device server receives a START STOP UNIT command with the POWER CONDITION field set to ACTIVE; or
- c) the device server receives a command that requires the logical unit to be in the SSU_PC1:Active state to process the command.

4.15.2.4.3 Transition SSU_PC2:Idle to SSU_PC3:Standby

This transition shall occur after:

- a) the device server receives a START STOP UNIT command with the POWER CONDITION field set to STANDBY;
- b) the device server receives a START STOP UNIT command with the POWER CONDITION field set to FORCE_STANDBY_0; or
- c) the standby condition timer is active (see SPC-4), enabled (see 5.17), and zero.

4.15.2.4.4 Transition SSU_PC2:Idle to SSU_PC4:Stopped

This transition shall occur after the device server receives a START STOP UNIT command with the START bit set to zero.

4.15.2.5 SSU_PC3:Standby state**4.15.2.5.1 SSU_PC3:Standby state description**

While in this state the logical unit is in the standby power condition (see SPC-4).

4.15.2.5.2 Transition SSU_PC3:Standby to SSU_PC1:Active

This transition shall occur after:

- a) the device server receives a START STOP UNIT command with the START bit set to one;
- b) the device server receives a START STOP UNIT command with the POWER CONDITION field set to ACTIVE; or
- c) the device server receives a command that requires the logical unit to be in the SSU_PC1:Active state to process the command.

4.15.2.5.3 Transition SSU_PC3:Standby to SSU_PC2:Idle

This transition shall occur after:

- a) the device server receives a START STOP UNIT command with the POWER CONDITION field set to IDLE;
- b) the device server receives a START STOP UNIT command with the POWER CONDITION field set to FORCE_IDLE_0; or
- c) the device server receives a command that requires the logical unit to be in the SSU_PC2:Idle state to process the command.

4.15.2.5.4 Transition SSU_PC3:Standby to SSU_PC4:Stopped

This transition shall occur after the device server receives a START STOP UNIT command with the START bit set to zero.

4.15.2.6 SSU_PC4:Stopped state**4.15.2.6.1 SSU_PC4:Stopped state description**

While in this state:

- a) the device server is not capable of processing medium access commands. Any medium access commands received while in this state shall cause the device server to terminate the command with CHECK CONDITION status with the sense key set to NOT READY and the additional sense code set to LOGICAL UNIT NOT READY, INITIALIZING COMMAND REQUIRED; and
- b) the power consumed by the SCSI target device should be less than or equal to that consumed than when the logical unit is in the SSU_PC1:Active, SSU_PC2:Idle, or SSU_PC3:Standby states.

4.15.2.6.2 Transition SSU_PC4:Stopped to SSU_PC1:Active

This transition shall occur after:

- a) the device server receives a START STOP UNIT command with the START bit set to one; or
- b) the device server receives a START STOP UNIT command with the POWER CONDITION field set to ACTIVE.

4.15.2.6.3 Transition SSU_PC4:Stopped to SSU_PC2:Idle

This transition shall occur after:

- a) the device server receives a START STOP UNIT command with the POWER CONDITION field set to IDLE; or
- b) the device server receives a START STOP UNIT command with the POWER CONDITION field set to FORCE_IDLE_0.

4.15.2.6.4 Transition SSU_PC4:Stopped to SSU_PC3:Standby

This transition shall occur after:

- a) the device server receives a START STOP UNIT command with the POWER CONDITION field set to STANDBY; or
- b) the device server receives a START STOP UNIT command with the POWER CONDITION field set to FORCE_STANDBY_0.

4.16 Protection information model**4.16.1 Protection information overview**

The protection information model provides for protection of user data while it is being transferred between a sender and a receiver. Protection information is generated at the application layer and may be checked by any object associated with the I_T_L nexus. Once received, protection information is retained (e.g., written to medium, stored in non-volatile memory, or recalculated on read back) by the device server until overwritten. Power loss, hard reset, logical unit reset, and I_T nexus loss shall have no effect on the retention of protection information.

Support for protection information shall be indicated in the PROTECT bit in the standard INQUIRY data (see SPC-4).

For commands that are using protection information, the data-in buffer and/or data-out buffer shall consist of logical blocks with both user data and protection information. For commands that are not using protection information, the data-in buffer and/or data-out buffer shall consist of logical blocks with only user data.

If the logical unit is formatted with protection information and the EMDP bit is set to one in the Disconnect-Reconnect mode page (see SPC-4), then checking of the logical block reference tag within the service delivery subsystem without accounting for modified data pointers and data alignments may cause false errors when logical blocks are transmitted out of order.

4.16.2 Protection information format

Table 7 defines the placement of protection information in a logical block.

Table 7 — User data and protection information format

Byte/Bit	7	6	5	4	3	2	1	0	
0	USER DATA								
n - 1	USER DATA								
n	(MSB)	LOGICAL BLOCK GUARD							
n + 1		LOGICAL BLOCK GUARD							(LSB)
n + 2	(MSB)	LOGICAL BLOCK APPLICATION TAG							
n + 3		LOGICAL BLOCK APPLICATION TAG							(LSB)
n + 4	(MSB)	LOGICAL BLOCK REFERENCE TAG							
n + 7		LOGICAL BLOCK REFERENCE TAG							(LSB)

The USER DATA field shall contain user data. The contents of the USER DATA field shall be used to generate and check the CRC contained in the LOGICAL BLOCK GUARD field.

The LOGICAL BLOCK GUARD field contains the CRC (see 4.16.3) of the contents of the USER DATA field.

The LOGICAL BLOCK APPLICATION TAG field is set by the application client. A LOGICAL BLOCK APPLICATION TAG field set to FFFFh disables checking of all protection information for the logical block when reading from the medium. Otherwise, the contents of the logical block application tag are not defined by this standard. The LOGICAL BLOCK APPLICATION TAG field may be modified by a device server if the ATO bit is set to zero in the Control mode page (see SPC-4). The contents of the LOGICAL BLOCK APPLICATION TAG field shall not be used to generate or check the CRC contained in the LOGICAL BLOCK GUARD field.

The LOGICAL BLOCK REFERENCE TAG field is an incrementing value associated with the logical block. The LOGICAL BLOCK REFERENCE TAG field of the first logical block in the data-in buffer and/or data-out buffer depends on the command being processed:

- a) for a command that does not include an EXPECTED INITIAL LOGICAL BLOCK REFERENCE TAG field (e.g., READ (16)), the LOGICAL BLOCK REFERENCE TAG field of the first logical block in the data-in buffer and/or data-out buffer shall contain the least significant four bytes of the LBA contained in the LOGICAL BLOCK ADDRESS field of the command; and
- b) for a command that does include an EXPECTED INITIAL LOGICAL BLOCK REFERENCE TAG field (e.g., READ (32)), the LOGICAL BLOCK REFERENCE TAG field of the first logical block shall contain the value in the EXPECTED INITIAL LOGICAL BLOCK REFERENCE TAG field of the command. These commands are only processed if the medium was formatted with application client ownership of the logical block reference tag (i.e., with the RTO_REQ bit set to one in the FORMAT UNIT command (see 5.2)).

Each subsequent logical block in the data-in buffer and/or data-out buffer shall contain a LOGICAL BLOCK REFERENCE TAG field with the logical block reference tag of the previous logical block plus one. The contents of the LOGICAL BLOCK REFERENCE TAG field shall not be used to generate or check the CRC contained in the LOGICAL BLOCK GUARD field.

4.16.3 Logical block guard

4.16.3.1 Logical block guard overview

The LOGICAL BLOCK GUARD field shall contain a CRC that is generated from the contents of the USER DATA field.

Table 8 defines the CRC polynomials used to generate the logical block guard from the contents of the USER DATA field.

Table 8 — CRC polynomials

Function	Definition
$F(x)$	A polynomial representing the transmitted USER DATA field, which is covered by the CRC. For the purposes of the CRC, the coefficient of the highest order term shall be byte zero bit seven of the USER DATA field and the coefficient of the lowest order term shall be bit zero of the last byte of the USER DATA field.
$F'(x)$	A polynomial representing the received USER DATA field.
$G(x)$	The generator polynomial: $G(x) = x^{16} + x^{15} + x^{11} + x^9 + x^8 + x^7 + x^5 + x^4 + x^2 + x + 1$ (i.e., $G(x) = 18BB7h$)
$R(x)$	The remainder polynomial calculated during CRC generation by the transmitter, representing the transmitted LOGICAL BLOCK GUARD field.
$R'(x)$	A polynomial representing the received LOGICAL BLOCK GUARD field.
$RB(x)$	The remainder polynomial calculated during CRC checking by the receiver. $RB(x) = 0$ indicates no error was detected.
$RC(x)$	The remainder polynomial calculated during CRC checking by the receiver. $RC(x) = 0$ indicates no error was detected.
$QA(x)$	The quotient polynomial calculated during CRC generation by the transmitter. The value of $QA(x)$ is not used.
$QB(x)$	The quotient polynomial calculated during CRC checking by the receiver. The value of $QB(x)$ is not used.
$QC(x)$	The quotient polynomial calculated during CRC checking by the receiver. The value of $QC(x)$ is not used.
$M(x)$	A polynomial representing the transmitted USER DATA field followed by the transmitted LOGICAL BLOCK GUARD field.
$M'(x)$	A polynomial representing the received USER DATA field followed by the received LOGICAL BLOCK GUARD field.

4.16.3.2 CRC generation

The equations that are used to generate the CRC from $F(x)$ are as follows. All arithmetic is modulo 2.

The transmitter shall calculate the CRC by appending 16 zeros to $F(x)$ and dividing by $G(x)$ to obtain the remainder $R(x)$:

$$\frac{x^{16} \times F(x)}{G(x)} = QA(x) + \frac{R(x)}{G(x)}$$

$R(x)$ is the CRC value, and is transmitted in the LOGICAL BLOCK GUARD field.

$M(x)$ is the polynomial representing the USER DATA field followed by the LOGICAL BLOCK GUARD field (i.e., $F(x)$ followed by $R(x)$):

$$M(x) = (x^{16} \times F(x)) + R(x)$$

4.16.3.3 CRC checking

$M'(x)$ (i.e., the polynomial representing the received USER DATA field followed by the received LOGICAL BLOCK GUARD field) may differ from $M(x)$ (i.e., the polynomial representing the transmitted USER DATA field followed by the transmitted LOGICAL BLOCK GUARD field) if there are transmission errors.

The receiver may check $M'(x)$ validity by appending 16 zeros to $F'(x)$ and dividing by $G(x)$ and comparing the calculated remainder $RB(x)$ to the received CRC value $R'(x)$:

$$\frac{x^{16} \times F'(x)}{G(x)} = QB(x) + \frac{RB(x)}{G(x)}$$

In the absence of errors in $F'(x)$ and $R'(x)$, the remainder $RB(x)$ is equal to $R'(x)$.

The receiver may check $M'(x)$ validity by dividing $M'(x)$ by $G(x)$ and comparing the calculated remainder $RC(x)$ to zero:

$$\frac{M'(x)}{G(x)} = QC(x) + \frac{RC(x)}{G(x)}$$

In the absence of errors in $F'(x)$ and $R'(x)$, the remainder $RC(x)$ is equal to zero.

Both methods of checking $M'(x)$ validity are mathematically equivalent.

4.16.3.4 CRC test cases

Several CRC test cases are shown in table 9.

Table 9 — CRC test cases

Pattern	CRC
32 bytes each set to 00h	0000h
32 bytes each set to FFh	A293h
32 bytes of an incrementing pattern from 00h to 1Fh	0224h
2 bytes each set to FFh followed by 30 bytes set to 00h	21B8h
32 bytes of a decrementing pattern from FFh to E0h	A0B7h

4.16.4 Application of protection information

Before an application client transmits or receives logical blocks with protection information it shall:

- 1) determine if a logical unit supports protection information using the INQUIRY command (see the PROTECT bit in the standard INQUIRY data in SPC-4);
- 2) if protection information is supported, then determine if the logical unit is formatted to accept protection information using the READ CAPACITY (16) command (see the PROT_EN bit in 5.11); and
- 3) if the logical unit supports protection information and is not formatted to accept protection information, then format the logical unit with protection information enabled.

If the logical unit supports protection information and is formatted to accept protection information, then the application client may use commands performing read operations that support protection information and should use commands performing write and verify operations that support protection information.

4.16.5 Protection information and commands

The enabling of protection information enables fields in some commands that instruct the device server on the handling of protection information. The detailed definitions of each command's protection information fields are in the individual command descriptions.

The commands that are affected when protection information is enabled are listed in table 10 (see 5.1).

Commands that return the length in bytes of each logical block (e.g., the MODE SENSE commands and the READ CAPACITY commands) shall return the length of the USER DATA field and shall not include the length of the protection information (i.e., the LOGICAL BLOCK GUARD field, the LOGICAL BLOCK APPLICATION TAG field, and the LOGICAL BLOCK REFERENCE TAG field) (e.g., if the user data plus the protection information is equal to 520 bytes then 512 is returned).

4.17 Grouping function

A grouping function is a function that collects information about attributes associated with commands (i.e., information about commands with the same group value are collected into the specified group). The definition of the attributes and the groups is outside the scope of this standard. Groups are identified with the GROUP NUMBER field in the CDB of certain commands (e.g., the PRE-FETCH (10) command (see 5.3)).

The collection of this information is outside the scope of this standard (e.g., the information may not be transmitted using any SCSI protocols).

NOTE 7 - An example of how grouping could be used, consider two applications using a subsystem; one application streams data and another accesses data randomly. If the streaming application groups all of its commands with one value (e.g., x), and the random application groups all of its commands with another value (e.g., y), then a group x defined to hold performance metrics collects all the performance metrics for the streamed commands together and a group y defined to also hold performance metrics collects all the performance metrics for the random commands together. The result is two sets of performance metrics (i.e., x and y). A management application then reads the performance metrics and determines if the performance of a specific group is acceptable.

Support for the grouping function is indicated in the GROUP_SUP bit in the Extended INQUIRY Data VPD page (see SPC-4).

4.18 Background scanning operations

4.18.1 Background scanning overview

Medium scanning occurs when a device server reads logical blocks from the medium for the purpose of:

- a) identifying logical blocks that are difficult to read or unreadable;
- b) logging a read problems; and
- c) when allowed, take a vendor specific action to make the logical block readable again.

Background medium scanning is defined as any operation that is performed without using any bandwidth on the service delivery subsystem (see SAM-4). Logical blocks shall not be retained in cache after they are read.

If a logical block is readable but requires extra actions (e.g., retries or application of correction algorithm) to be read, the device server may resolve the problem using vendor specific means. The ARRE bit in the Read-Write Error Recovery mode page (see 6.3.5) controls whether the device server may automatically repair or relocate recoverable read errors.

If a logical block is unreadable the device server may mark the logical block as bad so it may be relocated. The AWRE bit in the Read-Write Error Recovery mode page (see 6.3.5) controls whether the device server may relocate logical blocks during write operations. If allowed by AWRE bits setting, logical blocks that have previously been noted as unrecoverable are reassigned at the start of the next write operation to that logical block.

4.18.2 Background pre-scan feature

4.18.2.1 Enabling background pre-scan operation

The background pre-scan feature is enabled after:

- 1) the EN_PS bit in the Background Control mode page (see 6.3.3) is set to zero;
- 2) the EN_PS bit is set to one; and
- 3) the SCSI device is power cycled.

After power is restored the pre-scan timer is set to zero and the SCSI device begins scanning the medium starting at LBA zero and ending with the last LBA. During this time any commands from an application client shall cause the pre-scan operation to be suspended while the device server processes the commands. The pre-scan operation shall resume where it left off when all commands have been completed (i.e., no ACA exists).

A write operation that accesses an LBA that has not been scanned during the pre-scan operation is converted into a write operation followed by a verify operation to verify that the data just written was read back successfully. If a write operation accesses an LBA that has already been scanned during the pre-scan operation then it is processed normally. Commands that do not perform write operations are processed normally.

4.18.2.2 Halting background pre-scan operation

The background pre-scan feature is halted when any of the following occurs:

- a) the pre-scan operation completes scanning all LBAs on the SCSI device;
- b) an application client sets the EN_PS bit to zero (see 6.3.3);
- c) the pre-scan timer reaches the value of the PRE-SCAN TIMEOUT VALUE field (see 6.3.3); or
- d) the SCSI device detects a vendor specific pattern of errors.

Once the pre-scan is halted, it may be re-enabled as described in 4.18.2.1.

4.18.3 Background medium scan feature

4.18.3.1 Enabling background medium scan operation

If background pre-scan operation is enabled, it shall be completed or halted before background medium scan operation is started. The background medium scan feature is enabled by setting the EN_BMS bit in the Background Control mode page (see 6.3.x) to one. After the value in the BMS INTERVAL TIME field (see 6.3.3) has been reached, the device shall begin scanning the medium starting at LBA zero and ending with the last LBA. During this scan any commands from an application client shall cause the background medium scan operation to be suspended while the device server processes the commands. The background medium scan operation shall resume where it left off when all commands have been completed (i.e., no ACA exists).

After the last LBA has been scanned, the BMS INTERVAL TIMER field shall be set to zero and the background medium scan operation becomes dormant for a BMS interval time. Then the background medium scan operation starts another scanning cycle at LBA zero.

4.18.3.2 Suspending background medium scan operation

The background medium scan feature is suspended when any of the following occurs:

- a) the background medium scan operation completes scanning all LBAs on the SCSI device;
- b) an application client sets the EN_BMS bit to zero (see 6.3.3); or
- c) the SCSI device detects a vendor specific pattern of errors.

Once the background medium scan is suspended, it resumes at the logical block where it left off when it is enabled (see 4.18.3.1).

4.18.4 Interpreting the logged results

An application client may:

- a) poll the Background Scan Results log page (see 6.2.2) to get information about pre-scan and background medium scan activity; or
- b) use the EBACKERR bit and the MRIE field in the Informational Exceptions Control mode page (see SPC-4) to select a method of indicating a failure occurred. If the EBACKERR bit is set to one and a failure occurs the following additional sense codes shall be returned using the method defined in the MRIE field:
 - A) if the failure occurs during a pre-scan an additional sense code of WARNING - PRE-SCAN FAILED shall be returned; or

- B) if the failure occurs during a scan an additional sense code of WARNING - SCAN FAILED shall be returned.

If an application client polls the Background Scan Results log page (see 6.2.2) to get information about pre-scan and background medium scan activity, then the background scanning status parameter (see table 92) has fields that may be used to indicate whether a pre-scan or background medium scan is active or suspended, the number of scans performed on the medium, and the progress of a scan that is active. This information may be used by an application client to monitor the background scanning operations.

If an application client uses the EBACKERR bit and the MRIE field in the Informational Exceptions Control mode page (see SPC-4) to indicate an pre-scan or background medium scan failure and a failure occurs, then the application client should retrieve the Background Scan Results log page to get information about the failure.

The medium scan parameters (see table 94), if any, describe the physical and logical location of any suspected bad logical blocks. The REASSIGN STATUS field (see table 95) indicates whether the defect was completely handled by the device server or whether the application client may have to take action (e.g., reassigning or re-writing an LBA) to fix a particular logical block.

After an application client analyzes the medium scan parameters and has completed actions, if any, to repair the logical blocks, it may delete the log entries by issuing a LOG SELECT command with PCR bit set to one (see SPC-3).

5 Commands for direct-access block devices

5.1 Commands for direct-access block devices overview

The commands for direct-access block devices are listed in table 10. Commands with CDB or parameter data fields that support protection information (see 4.16) or for which protection information may be a factor in the processing of the command are indicated by the fourth (i.e., Protection information) column.

Table 10 — Commands for direct-access block devices (part 1 of 4)

Command name	Operation code ^a	Type ^b	Protection information	Reference
ACCESS CONTROL IN	86h	O	no	SPC-4
ACCESS CONTROL OUT	87h	O	no	SPC-4
CHANGE ALIASES	A4h/0Bh	O	no	SPC-4
EXTENDED COPY	83h	O	no	SPC-4
FORMAT UNIT	04h	M	yes	5.2
INQUIRY	12h	M	yes	SPC-4
LOG SELECT	4Ch	O	no	SPC-4
LOG SENSE	4Dh	O	no	SPC-4
MAINTENANCE IN	A3h/00h - 04h A3h/06h - 09h	X ^e	no	SCC-2
MAINTENANCE OUT	A4h/00h - 05h A4h/07h - 09h	X ^e	no	SCC-2
MODE SELECT (6)	15h	O	no	SPC-4
MODE SELECT (10)	55h	O	no	SPC-4
MODE SENSE (6)	1Ah	O	no	SPC-4
MODE SENSE (10)	5Ah	O	no	SPC-4
MOVE MEDIUM ATTACHED	A7h	X ^f	no	SMC-2
PERSISTENT RESERVE IN	5Eh	O	no	SPC-4
PERSISTENT RESERVE OUT	5Fh	O	no	SPC-4
PRE-FETCH (10)	34h	O	no	5.3
PRE-FETCH (16)	90h	O	no	5.4
PREVENT ALLOW MEDIUM REMOVAL	1Eh	O	no	SPC-4
READ (6)	08h	M ^c	yes	5.5
READ (10)	28h	M	yes	5.6
READ (12)	A8h	O	yes	5.7
READ (16)	88h	O	yes	5.8
READ (32)	7Fh/0009h	O	yes	5.9
READ ATTRIBUTE	8Ch	O	no	SPC-4
READ BUFFER	3Ch	O	no	SPC-4
READ CAPACITY (10)	25h	M	no	5.10

Table 10 — Commands for direct-access block devices (part 2 of 4)

Command name	Operation code ^a	Type ^b	Protection information	Reference
READ CAPACITY (16)	9Eh/10h	X ^d	yes	5.11
READ DEFECT DATA (10)	37h	O	no	5.12
READ DEFECT DATA (12)	B7h	O	no	5.13
READ ELEMENT STATUS ATTACHED	B4h	X ^f	no	SMC-2
READ LONG (10)	3Eh	O	yes	5.14
READ LONG (16)	9Eh/11h	O	yes	5.15
REASSIGN BLOCKS	07h	O	no	5.16
RECEIVE COPY RESULTS	84h	O	no	SPC-4
RECEIVE DIAGNOSTIC RESULTS	1Ch	O/M ^g	no	SPC-4
REDUNDANCY GROUP IN	BAh	X ^e	no	SCC-2
REDUNDANCY GROUP OUT	BBh	X ^e	no	SCC-2
REPORT ALIASES	A3h/0Bh	O	no	SPC-4
REPORT DEVICE IDENTIFIER	A3h/05h	O	no	SPC-4
REPORT LUNS	A0h	M	no	SPC-4
REPORT PRIORITY	A3h/0Eh	O	no	SPC-4
REPORT SUPPORTED OPERATION CODES	A3h/0Ch	O	no	SPC-4
REPORT SUPPORTED TASK MANAGEMENT FUNCTIONS	A3h/0Dh	O	no	SPC-4
REPORT TARGET PORT GROUPS	A3h/0Ah	O	no	SPC-4
REQUEST SENSE	03h	M	no	SPC-4
SEND DIAGNOSTIC	1Dh	M	no	SPC-4
SET DEVICE IDENTIFIER	A4h/06h	O	no	SPC-4
SET PRIORITY	A4h/0Eh	O	no	SPC-4
SET TARGET PORT GROUPS	A4h/0Ah	O	no	SPC-4
SPARE IN	BCh	X ^e	no	SCC-2
SPARE OUT	BDh	X ^e	no	SCC-2
START STOP UNIT	1Bh	O	no	5.17
SYNCHRONIZE CACHE (10)	35h	O	no	5.18
SYNCHRONIZE CACHE (16)	91h	O	no	5.19
TEST UNIT READY	00h	M	no	SPC-4
VERIFY (10)	2Fh	O	yes	5.20
VERIFY (12)	AFh	O	yes	5.21
VERIFY (16)	8Fh	O	yes	5.22
VERIFY (32)	7Fh/000Ah	O	yes	5.23
VOLUME SET IN	BEh	X ^e	no	SCC-2

Table 10 — Commands for direct-access block devices (part 3 of 4)

Command name	Operation code ^a	Type ^b	Protection information	Reference
VOLUME SET OUT	BFh	X ^e	no	SCC-2
WRITE (6)	0Ah	O ^c	yes	5.24
WRITE (10)	2Ah	O	yes	5.25
WRITE (12)	AAh	O	yes	5.26
WRITE (16)	8Ah	O	yes	5.27
WRITE (32)	7Fh/000Bh	O	yes	5.28
WRITE AND VERIFY (10)	2Eh	O	yes	5.29
WRITE AND VERIFY (12)	A Eh	O	yes	5.30
WRITE AND VERIFY (16)	8Eh	O	yes	5.31
WRITE AND VERIFY (32)	7Fh/000Ch	O	yes	5.32
WRITE ATTRIBUTE	8Dh	O	no	SPC-4
WRITE BUFFER	3Bh	O	no	SPC-4
WRITE LONG (10)	3Fh	O	yes	5.33
WRITE LONG (16)	9Fh/11h	O	yes	5.34
WRITE SAME (10)	41h	O	yes	5.35
WRITE SAME (16)	93h	O	yes	5.36
WRITE SAME (32)	7Fh/000Dh	O	yes	5.37
XDREAD (10)	52h	O	yes	5.38
XDREAD (32)	7Fh/0003h	O	yes	5.39

Table 10 — Commands for direct-access block devices (part 4 of 4)

Command name	Operation code ^a	Type ^b	Protection information	Reference
XDWRITE (10)	50h	O	yes	5.40
XDWRITE (32)	7Fh/0004h	O	yes	5.41
XDWRITEREAD (10)	53h	O	yes	5.42
XDWRITEREAD (32)	7Fh/0007h	O	yes	5.43
XPWRITE (10)	51h	O	yes	5.44
XPWRITE (32)	7Fh/0006h	O	yes	5.45
<p>The following operation codes are obsolete: 01h (REZERO UNIT), 0Bh (SEEK (6)), 16h (RESERVE (6)), 17h (RELEASE (6)), 18h (COPY), 2Bh (SEEK (10)), 30h (SEARCH DATA HIGH (10)), 31h (SEARCH DATA EQUAL (10)), 32h (SEARCH DATA LOW (10)), 33h (SET LIMITS (10)), 36h (LOCK UNLOCK CACHE (10)), 39h (COMPARE), 3Ah (COPY AND VERIFY), 40h (CHANGE DEFINITION), 56h (RESERVE (10)), 57h (RELEASE (10h)), 80h (XDWRITE EXTENDED (16)), 81h (REBUILD (16)), 82h (REGENERATE (16)), 92h (LOCK UNLOCK CACHE (16)), and B3h (SET LIMITS (12)).</p> <p>The following operation codes are vendor-specific: 02h, 05h, 06h, 09h, 0Ch, 0Dh, 0Eh, 0Fh, 10h, 11h, 13h, 14h, 19h, 20h, 21h, 22h, 23h, 24h, 26h, 27h, 29h, 2Ch, 2Dh, and C0h through FFh.</p> <p>All operation codes for direct-access block devices not specified in this table are reserved for future standardization.</p>				
<p>^a Some commands are defined by a combination of operation code and service action. The operation code value is shown preceding the slash and the service action value is shown after the slash. ^b M = command implementation is mandatory. O = command implementation is optional. X = Command implementation requirements detailed in the reference. ^c Application clients should migrate from READ (6) to READ (10) (see 5.5) and from WRITE (6) to WRITE (10) (see 5.24). ^d READ CAPACITY (16) is mandatory if protection information is supported and optional otherwise. ^e If the SCCS bit is set to one in the standard INQUIRY data (see SPC-4), these commands shall be supported as required by SCC-2. If the SCCS bit is set to zero, these commands shall not be supported. ^f If the MCHGR bit is set to one in the standard INQUIRY data (see SPC-4), these commands shall be supported as required in SMC-2. If the MCHGR bit is set to zero, these commands shall not be supported. ^g This command shall be supported if the ENCSERV bit is set to one in the standard INQUIRY data (see SPC-4) and may be supported otherwise.</p>				

5.2 FORMAT UNIT command

5.2.1 FORMAT UNIT command overview

The FORMAT UNIT command (see table 11) requests that the device server format the medium into application client accessible logical blocks as specified in the number of blocks and block length values received in the last mode parameter block descriptor (see 6.3.2) in a MODE SELECT command (see SPC-4). In addition, the device server may certify the medium and create control structures for the management of the medium and defects. The degree that the medium is altered by this command is vendor-specific.

If a device server receives a FORMAT UNIT command before receiving a MODE SELECT command with a mode parameter block descriptor the device server shall use the number of blocks and block length at which the logical unit is currently formatted (i.e., no change is made to the number of blocks and the block length of the logical unit during the format operation).

Table 11 — FORMAT UNIT command

Byte/Bit	7	6	5	4	3	2	1	0
0	OPERATION CODE (04h)							
1	FMTPINFO	RTO_REQ	LONGLIST	FMTDATA	CMPLIST	DEFECT LIST FORMAT		
2	Vendor specific							
3	Obsolete							
4	Obsolete							
5	CONTROL							

The simplest form of the FORMAT UNIT command (i.e., a FORMAT UNIT command with no parameter data) accomplishes medium formatting with little application client control over defect management. The device server implementation determines the degree of defect management that is to be performed. Additional forms of this command increase the application client's control over defect management. The application client may specify:

- a) defect list(s) to be used;
- b) defect locations;
- c) that logical unit certification be enabled; and
- d) exception handling in the event that defect lists are not accessible.

While performing a format operation, the device server shall respond to commands attempting to enter into the task set except INQUIRY commands, REPORT LUNS commands, and REQUEST SENSE commands with CHECK CONDITION status with the sense key set to NOT READY and the additional sense code set to LOGICAL UNIT NOT READY, FORMAT IN PROGRESS. Handling of commands already in the task set is vendor-specific.

The PROGRESS INDICATION field in parameter data returned in response to a REQUEST SENSE command (see SPC-4) may be used by the application client at any time during a format operation to poll the logical unit's progress. While a format operation is in progress unless an error has occurred, a device server shall respond to a REQUEST SENSE command by returning parameter data containing sense data with the sense key set to NOT READY and the additional sense code set to LOGICAL UNIT NOT READY, FORMAT IN PROGRESS with the sense key specific bytes set for progress indication (see SPC-4).

A format protection information (FMTPINFO) bit set to zero specifies that the device server shall disable the use of protection information (see 4.16) and format the medium to the block length specified in the mode parameter block descriptor of the mode parameter header (see SPC-4). A FMTPINFO bit set to one specifies that the device server shall enable the use of protection information (see 4.16) and format the medium to the block length specified in the mode parameter block descriptor of the mode parameter header plus eight (e.g., if the block length is 512, then the formatted block length is 520). Following a successful format, the PROT_EN bit in the READ CAPACITY (16) parameter data (see 5.11) indicates whether protection information (see 4.16) is enabled.

The reference tag own request (RTO_REQ) bit specifies whether the application client or the device server has ownership of the LOGICAL BLOCK REFERENCE TAG field in protection information (see 4.16.2). If the FMTPINFO bit is set to zero and the RTO_REQ bit is set to one, the device server shall terminate the command with CHECK CONDITION status with the sense key set to ILLEGAL REQUEST and the additional sense code set to INVALID FIELD IN CDB. If the FMTPINFO bit is set to one and the RTO_REQ bit is set to one, the device server shall enable application client ownership of the LOGICAL BLOCK REFERENCE TAG field. If the FMTPINFO bit set to one and the RTO_REQ bit is set to zero, the device server shall disable application client ownership (i.e., enable device server ownership) of the LOGICAL BLOCK REFERENCE TAG field. Following a successful format,

the RTO_EN bit in the READ CAPACITY (16) parameter data (see 5.11) indicates whether application client ownership of the LOGICAL BLOCK REFERENCE TAG field is enabled.

When protection information is written during a FORMAT UNIT command (i.e., the FMTPINFO bit is set to one) protection information shall be written to a default value of FFFFFFFF_FFFFFFFFh.

A LONGLIST bit set to zero specifies that the parameter list, if any, contains a short parameter list header as defined in table 14. A LONGLIST bit set to one specifies that the parameter list, if any, contains a long parameter list header as defined in table 15. If the FMTDATA bit is set to zero, the LONGLIST bit shall be ignored.

A format data (FMTDATA) bit set to zero specifies that no parameter list be transferred from the data-out buffer.

A FMTDATA bit set to one specifies that the FORMAT UNIT parameter list (see table 13) shall be transferred from the data-out buffer. The parameter list consists of a parameter list header, followed by an optional initialization pattern descriptor, followed by an optional defect list.

A complete list (CMPLST) bit set to zero specifies that the defect list included in the FORMAT UNIT parameter list shall be used in an addition to the existing list of defects. As a result, the device server shall construct a new GLIST (see 4.8) that contains:

- a) the existing GLIST;
- b) the DLIST, if it is sent by the application client; and
- c) the CLIST, if certification is enabled (i.e., the device server may add any defects it detects during the format operation).

A CMPLST bit set to one specifies that the defect list included in the FORMAT UNIT parameter list is a complete list of defects. Any existing defect list except the PLIST shall be ignored by the device server. As a result, the device server shall construct a new GLIST (see 4.8) that contains:

- a) the DLIST, if it is sent by the application client; and
- b) the CLIST, if certification is enabled (i.e., the device server may add any defects it detects during the format operation).

If the FMTDATA bit is set to zero, the CMPLIST bit shall be ignored.

The DEFECT LIST FORMAT field specifies the format of the address descriptors in the defect list if the FMTDATA bit is set to one (see table 12).

Table 12 defines the address descriptor usage for the FORMAT UNIT command.

Table 12 — FORMAT UNIT command address descriptor usage

Field in the FORMAT UNIT CDB			DEFECT LIST LENGTH field in the parameter list header	Type ^a	Comments ^f
FMTDATA	CMPLST	DEFECT LIST FORMAT			
0	any	000b	Not available	M	Vendor-specific defect information
1	0	000b (short block)	Zero	O	See ^b and ^d
1	1			O	See ^b and ^e
1	0		Nonzero	O	See ^c and ^d
1	1			O	See ^b and ^e
		011b (long block)	Zero	O	See ^b and ^d
				O	See ^b and ^e
1	0		Nonzero	O	See ^c and ^d
1	1			O	See ^c and ^e
1	0	100b (bytes from index)	Zero	O	See ^b and ^d
1	1			O	See ^b and ^e
1	0		Nonzero	O	See ^c and ^d
1	1			O	See ^c and ^e
1	0	101b (physical sector)	Zero	O	See ^b and ^d
1	1			O	See ^b and ^e
1	0		Nonzero	O	See ^c and ^d
1	1			O	See ^c and ^e
1	0	110b (vendor specific)	Vendor specific	O	
1	1			O	
All others				Reserved.	

- ^a M = implementation is mandatory. O = implementation is optional.
- ^b No DLIST is included in the parameter list.
- ^c A DLIST is included in the parameter list. The device server shall add the DLIST defects to the new GLIST.
- ^d The device server shall add existing GLIST defects to the new GLIST (i.e., use the existing GLIST).
- ^e The device server shall not add existing GLIST defects to the new GLIST (i.e., discard the existing GLIST).
- ^f All the options described in this table cause a new GLIST to be created during processing of the FORMAT UNIT command as described in the text.

5.2.2 FORMAT UNIT parameter list

5.2.2.1 FORMAT UNIT parameter list overview

Table 13 defines the FORMAT UNIT parameter list.

Table 13 — FORMAT UNIT parameter list

Byte\Bit	7	6	5	4	3	2	1	0
0 to 3 or 0 to 7	Parameter list header (see table 14 or table 15 in 5.2.2.2)							
	Initialization pattern descriptor (if any)(see table 16 in 5.2.2.3)							
	Defect list (if any)							

The parameter list header is defined in 5.2.2.2.

The initialization pattern descriptor, if any, is defined in 5.2.2.3.

The defect list, if any, contains address descriptors (see 5.2.2.4) each specifying a location on the medium that the device server shall exclude from the application client accessible part. This is called the DLIST (see 4.8)

5.2.2.2 Parameter list header

The parameter list headers (see table 14 and table 15) provide several optional format control parameters. Device servers that implement these headers provide the application client additional control over the use of the four defect sources, and the format operation. If the application client attempts to select any function not implemented by the device server, the device server shall terminate the command with CHECK CONDITION status with the sense key set to ILLEGAL REQUEST and the additional sense code set to INVALID FIELD IN PARAMETER LIST.

The short parameter list header (see table 14) is used if the LONGLIST bit is set to zero in the FORMAT UNIT CDB.

Table 14 — Short parameter list header

Byte\Bit	7	6	5	4	3	2	1	0
0	Reserved							
1	FOV	DPRY	DCRT	STPF	IP	Obsolete	IMMED	Vendor specific
2	(MSB) DEFECT LIST LENGTH (LSB)							
3								

The long parameter list header (see table 15) is used if the LONGLIST bit is set to one in the FORMAT UNIT CDB.

Table 15 — Long parameter list header

Byte\Bit	7	6	5	4	3	2	1	0	
0	Reserved								
1	FOV	DPRY	DCRT	STPF	IP	Obsolete	IMMED	Vendor specific	
2	Reserved								
3	Reserved								
4	(MSB)	DEFECT LIST LENGTH							
7								(LSB)	

A format options valid (FOV) bit set to zero specifies that the device server shall use its default settings for the DPRY, DCRT, STPF, and IP bits. If the FOV bit is set to zero, the application client shall set these bits to zero. If the FOV bit is set to zero and any of the other bits listed in this paragraph are not set to zero, the device server shall terminate the command with CHECK CONDITION status with the sense key set to ILLEGAL REQUEST and the additional sense code set to INVALID FIELD IN PARAMETER LIST.

A FOV bit set to one specifies that the device server shall examine the values of the DPRY, DCRT, STPF, and IP bits. When the FOV bit is set to one, the DPRY, DCRT, STPF, and IP bits are defined as follows.

A disable primary (DPRY) bit set to zero specifies that the device server shall not use parts of the medium identified as defective in the PLIST for application client accessible logical blocks. If the device server is not able to locate the PLIST or it is not able to determine whether a PLIST exists, it shall take the action specified by the STPF bit.

A DPRY bit set to one specifies that the device server shall not use the PLIST to identify defective areas of the medium. The PLIST shall not be deleted.

A disable certification (DCRT) bit set to zero specifies that the device server shall perform a vendor-specific medium certification operation to generate a CLIST. A DCRT bit set to one specifies that the device server shall not perform any vendor-specific medium certification process or format verification operation.

The stop format (STPF) bit controls the behavior of the device server if one of the following events occurs:

- a) The device server has been requested to use the PLIST (i.e., the DPRY bit is set to zero) or the GLIST (i.e., the CMLST bit is set to zero) and the device server is not able to locate the list or determine whether the list exists; or
- b) The device server has been requested to use the PLIST (i.e., the DPRY bit is set to zero) or the GLIST (i.e., the CMLST bit is set to zero), and the device server encounters an error while accessing the defect list.

A STPF bit set to zero specifies that, if one or both of these events occurs, the device server shall continue to process the FORMAT UNIT command. The device server shall return CHECK CONDITION status at the completion of the FORMAT UNIT command with the sense key set to RECOVERED ERROR and the additional sense code set to either DEFECT LIST NOT FOUND if the condition described in item a) occurred, or DEFECT LIST ERROR if the condition described in item b) occurred.

A STPF bit set to one specifies that, if one or both of these events occurs, the device server shall terminate the FORMAT UNIT command with CHECK CONDITION status and the sense key shall be set to MEDIUM ERROR with the additional sense code set to either DEFECT LIST NOT FOUND if the condition described in item a) occurred, or DEFECT LIST ERROR if the condition described in item b) occurred.

NOTE 8 - The use of the FMTDATA bit, the CMLST bit, and the parameter list header allow the application client to control the source of the defect lists used by the FORMAT UNIT command. Setting the DEFECT LIST

LENGTH field to zero allows the application client to control the use of PLIST and CLIST without having to specify a DLIST.

An initialization pattern (IP) bit set to zero specifies that an initialization pattern descriptor is not included and that the device server shall use its default initialization pattern. An IP bit set to one specifies that an initialization pattern descriptor (see 5.2.2.3) is included in the FORMAT UNIT parameter list following the parameter list header.

An immediate (IMMED) bit set to zero specifies that the device server shall return status after the format operation has completed. An IMMED bit value set to one specifies that the device server shall return status after the entire parameter list has been transferred.

The DEFECT LIST LENGTH field specifies the total length in bytes of the defect list (i.e., the address descriptors) that follows and does not include the initialization pattern descriptor, if any. The formats for the address descriptor(s) are shown in 5.2.2.4.

Short block format address descriptors and long block format address descriptors should be in ascending order. Bytes from index format address descriptors and physical sector format address descriptors shall be in ascending order. More than one physical or logical block may be affected by each address descriptor. If the address descriptors are not in the required order, the device server shall terminate the command with CHECK CONDITION status with the sense key set to ILLEGAL REQUEST and the additional sense code set to INVALID FIELD IN PARAMETER LIST.

5.2.2.3 Initialization pattern descriptor

The initialization pattern descriptor specifies that the device server initialize logical blocks to a specified pattern. The initialization pattern descriptor (see table 16) is sent to the device server as part of the FORMAT UNIT parameter list.

Table 16 — Initialization pattern descriptor

Byte	7	6	5	4	3	2	1	0
0	IP MODIFIER		SI	Reserved				
1	INITIALIZATION PATTERN TYPE							
2	(MSB)	INITIALIZATION PATTERN LENGTH (n - 3)						(LSB)
3								
4	INITIALIZATION PATTERN							
n								

The initialization pattern modifier (IP MODIFIER) field (see table 17) specifies the type and location of a header that modifies the initialization pattern.

Table 17 — Initialization pattern modifier (IP MODIFIER) field

Code	Description
00b	No header. The device server shall not modify the initialization pattern.
01b	The device server shall overwrite the initialization pattern to write the LBA in the first four bytes of each logical block. The LBA shall be written with the most significant byte first. If the LBA is larger than four bytes, the least significant four bytes shall be written ending with the least significant byte.
10b	The device server shall overwrite the initialization pattern to write the LBA in the first four bytes of each physical block contained within the logical block. The lowest numbered logical block or part thereof that occurs within the physical block is used. The LBA shall be written with the most significant byte first. If the LBA is larger than four bytes the least significant four bytes shall be written ending with the least significant byte.
11b	Reserved.

A security initialize (SI) bit set to one specifies that the device server shall attempt to write the initialization pattern to all areas of the medium including those that may have been reassigned (i.e., are in a defect list). An SI bit set to one shall take precedence over any other FORMAT UNIT CDB field. The initialization pattern shall be written using a security erasure write technique. Application clients may choose to use this command multiple times to fully erase the previous data. Such security erasure write technique procedures are outside the scope of this standard. The exact requirements placed on the security erasure write technique are vendor-specific. The intent of the security erasure write is to render any previous user data unrecoverable by any analog or digital technique.

An SI bit set to zero specifies that the device server shall initialize the application client accessible part of the medium. The device server is not required to initialize other areas of the medium. However, the device server shall format the medium as defined in the FORMAT UNIT command.

When the SI bit is set to one, the device server need not write the initialization pattern over the header and other header and other parts of the medium not previously accessible to the application client. If the device server is unable to write over any part of the medium that is currently accessible to the application client or may be made accessible to the application client in the future (e.g., by clearing the defect list), it shall terminate the command with CHECK CONDITION status with the sense key set to MEDIUM ERROR and the additional sense code set to the appropriate value for the condition. The device server shall attempt to rewrite all remaining parts of the medium even if some parts are not able to be rewritten.

The INITIALIZATION PATTERN TYPE field (see table 18) specifies the type of pattern the device server shall use to initialize each logical block within the application client accessible part of the medium. All bytes within a logical

block shall be written with the initialization pattern. The initialization pattern is modified by the IP MODIFIER field as described in table 17.

Table 18 — INITIALIZATION PATTERN TYPE field

Code	Description
00h	Use a default initialization pattern ^a
01h	Repeat the pattern specified in the INITIALIZATION PATTERN field as required to fill the logical block ^b
02h - 7Fh	Reserved
80h - FFh	Vendor-specific
^a If the INITIALIZATION PATTERN LENGTH field is not set to zero, the device server shall terminate the command with CHECK CONDITION status with the sense key set to ILLEGAL REQUEST and the additional sense code set to INVALID FIELD IN PARAMETER LIST. ^b If the INITIALIZATION PATTERN LENGTH field is set to zero, the device server shall terminate the command with CHECK CONDITION status with the sense key set to ILLEGAL REQUEST and the additional sense code set to INVALID FIELD IN PARAMETER LIST.	

The INITIALIZATION PATTERN LENGTH field specifies the number of bytes contained in the INITIALIZATION PATTERN field. If the initialization pattern length exceeds the current block length the device server shall terminate the command with CHECK CONDITION status with the sense key set to ILLEGAL REQUEST and the additional sense code set to INVALID FIELD IN PARAMETER LIST.

The INITIALIZATION PATTERN field specifies the initialization pattern. The initialization pattern is modified by the IP MODIFIER field.

5.2.2.4 Address descriptor formats

5.2.2.4.1 Address descriptor formats overview

This subclause describes the address descriptor formats used in the FORMAT UNIT command, the READ DEFECT DATA commands (see 5.12 and 5.13), and the Translate Address diagnostic pages (see 6.1.2 and 6.1.3) of the SEND DIAGNOSTIC command and the RECEIVE DIAGNOSTIC RESULTS command.

The format type of an address descriptor is specified with:

- a) the DEFECT LIST FORMAT field in the CDB, for the FORMAT UNIT command and the READ DEFECT DATA commands;
- b) the SUPPLIED FORMAT field, for the Translate Address diagnostic pages; or
- c) the TRANSLATE FORMAT field, for the Translate Address diagnostic pages.

Table 19 defines the types of address descriptors.

Table 19 — Address descriptor formats

Format type	Description	Reference
000b	Short block format address descriptor	5.2.2.4.2
011b	Long block format address descriptor	5.2.2.4.3
100b	Bytes from index format address descriptor	5.2.2.4.4
101b	Physical sector format address descriptor	5.2.2.4.5
110b	Vendor-specific	
All others	Reserved	

5.2.2.4.2 Short block format address descriptor

A format type of 000b specifies the short block format address descriptor defined in table 20.

Table 20 — Short block format address descriptor (000b)

Byte\Bit	7	6	5	4	3	2	1	0
0	(MSB)							
	SHORT BLOCK ADDRESS							
3	(LSB)							

For the FORMAT UNIT command, the SHORT BLOCK ADDRESS field contains the four-byte LBA of a defect. For the READ DEFECT DATA commands, the SHORT BLOCK ADDRESS field contains a vendor-specific four-byte value. For the Translate Address diagnostic pages, the SHORT BLOCK ADDRESS field contains a four-byte LBA or a vendor-specific four byte value that is greater than the capacity of the medium.

5.2.2.4.3 Long block format address descriptor

A format type of 011b specifies the long block format address descriptor defined in table 21.

Table 21 — Long block format address descriptor (011b)

Byte\Bit	7	6	5	4	3	2	1	0
0	(MSB)							
	LONG BLOCK ADDRESS							
7	(LSB)							

For the FORMAT UNIT command, the LONG BLOCK ADDRESS field contains the eight-byte logical block address of a defect. For the READ DEFECT DATA commands, the LONG BLOCK ADDRESS field contains a vendor-specific eight-byte value. For the Translate Address diagnostic pages, the LONG BLOCK ADDRESS field contains a four-byte LBA or a vendor-specific four byte value that is greater than the capacity of the medium.

5.2.2.4.4 Bytes from index format address descriptor

A format type of 100b specifies the bytes from index address descriptor defined in table 22. For the FORMAT UNIT command and the READ DEFECT DATA commands, this descriptor specifies the location of a defect that is either the length of one track or is no more than eight bytes long. For the Translate Address diagnostic pages, this descriptor specifies the location of a track or the first byte or last byte of an area.

Table 22 — Bytes from index format address descriptor (100b)

Byte\Bit	7	6	5	4	3	2	1	0
0	(MSB)							
	CYLINDER NUMBER							
2	(LSB)							
3	HEAD NUMBER							
4	(MSB)							
	BYTES FROM INDEX							
7	(LSB)							

The CYLINDER NUMBER field contains the cylinder number.

The HEAD NUMBER field contains the head number.

The BYTES FROM INDEX field contains the number of bytes from the index (e.g., from the start of the track) to the location being described. A BYTES FROM INDEX field set to FFFFFFFFh specifies that the entire track is being described.

For sorting bytes from index format address descriptors, the cylinder number is the most significant part of the address and the bytes from index is the least significant part of the address. More than one logical block may be described by this descriptor.

5.2.2.4.5 Physical sector format address descriptor

A format type of 101b specifies the physical sector address descriptor defined in table 23. For the FORMAT UNIT command and the READ DEFECT DATA commands, this descriptor specifies the location of a defect that is either the length of one track or the length of one sector. For the Translate Address diagnostic pages, this descriptor specifies the location of a track or a sector.

Table 23 — Physical sector format address descriptor (101b)

Byte\Bit	7	6	5	4	3	2	1	0	
0	(MSB)								
2	CYLINDER NUMBER							(LSB)	
3	HEAD NUMBER								
4	(MSB)								
7	SECTOR NUMBER							(LSB)	

The CYLINDER NUMBER field contains the cylinder number.

The HEAD NUMBER field contains the head number.

The SECTOR NUMBER field contains the sector number. A SECTOR NUMBER field set to FFFFFFFFh specifies that the entire track is being described.

For sorting physical sector format address descriptors, the cylinder number is the most significant part of the address and the sector number is the least significant part of the address. More than one logical block may be described by this descriptor.

5.3 PRE-FETCH (10) command

The PRE-FETCH (10) command (see table 24) requests that the device server transfer the specified logical blocks from the medium to the volatile cache and/or non-volatile cache. Logical blocks include user data and, if the medium is formatted with protection information enabled, protection information. No data shall be transferred to the data-in buffer.

Table 24 — PRE-FETCH (10) command

Byte\Bit	7	6	5	4	3	2	1	0	
0	OPERATION CODE (34h)								
1	Reserved						IMMED	Obsolete	
2	(MSB)								
5	LOGICAL BLOCK ADDRESS							(LSB)	
6	Reserved			GROUP NUMBER					
7	(MSB)								
8	PREFETCH LENGTH							(LSB)	
9	CONTROL								

An immediate (IMMED) bit set to zero specifies that status shall be returned after the operation is complete. An IMMED bit set to one specifies that status shall be returned as soon as the CDB has been validated.

The LOGICAL BLOCK ADDRESS field specifies the first logical block accessed by this command. If the logical block address exceeds the capacity of the medium the device server shall terminate the command with CHECK CONDITION status with the sense key set to ILLEGAL REQUEST and the additional sense code set to LOGICAL BLOCK ADDRESS OUT OF RANGE.

The GROUP NUMBER field specifies the group into which attributes associated with the command should be collected (see 4.17). A GROUP NUMBER field set to zero specifies that any attributes associated with the command shall not be collected into any group.

The PREFETCH LENGTH field specifies the number of contiguous logical blocks that shall be pre-fetched (i.e., transferred to the cache from the medium), starting with the logical block specified by the LOGICAL BLOCK ADDRESS field. A PREFETCH LENGTH field set to zero specifies that all logical blocks starting with the one specified in the LOGICAL BLOCK ADDRESS field to the last logical block on the medium shall be pre-fetched. Any other value specifies the number of logical blocks that shall be pre-fetched. If the logical block address plus the prefetch length exceeds the capacity of the medium, the device server shall terminate the command with CHECK CONDITION status with the sense key set to ILLEGAL REQUEST and the additional sense code set to LOGICAL BLOCK ADDRESS OUT OF RANGE. The device server is not required to transfer logical blocks that already are contained in the cache.

If the IMMED bit is set to zero and the specified logical blocks were successfully transferred to the cache, the device server shall return:

- a) CONDITION MET status if the LINK bit is set to zero in the CONTROL byte (see SPC-4); or
- b) INTERMEDIATE-CONDITION MET status if the LINK bit is set to one.

If the IMMED bit is set to zero and the cache does not have sufficient capacity to accept all of the specified logical blocks, the device server shall transfer to the cache as many of the specified logical blocks that fit. If these logical blocks are transferred successfully it shall return:

- a) GOOD status if the LINK bit is set to zero in the CONTROL byte (see SPC-4); or
- b) INTERMEDIATE status if the LINK bit is set to one.

If the IMMED bit is set to one and the cache has sufficient capacity to accept all of the specified logical blocks, the device server shall return:

- a) CONDITION MET status if the LINK bit is set to zero in the CONTROL byte (see SPC-4); or
- b) INTERMEDIATE-CONDITION MET status if the LINK bit is set to one.

If the IMMED bit is set to one and the cache does not have sufficient capacity to accept all of the specified logical blocks, the device server shall return:

- a) GOOD status if the LINK bit is set to zero in the CONTROL byte (see SPC-4); or
- b) INTERMEDIATE status if the LINK bit is set to one.

If the IMMED bit is set to zero and one or more of the specified logical blocks were not successfully transferred to the cache for reasons other than lack of cache capacity, the device server shall terminate the command with CHECK CONDITION status with the sense key and the additional sense code set to the appropriate values. If the IMMED bit is set to one and one or more of the specified logical blocks were not successfully transferred to the cache for reasons other than lack of cache capacity, the device server shall report a deferred error (see SPC-4).

5.4 PRE-FETCH (16) command

The PRE-FETCH (16) command (see table 25) requests that the device server transfer the specified logical blocks from the medium to the volatile cache and/or non-volatile cache. Logical blocks include user data and,

if the medium is formatted with protection information enabled, protection information. No data shall be transferred to the data-in buffer.

Table 25 — PRE-FETCH (16) command

Byte\Bit	7	6	5	4	3	2	1	0	
0	OPERATION CODE (90h)								
1	Reserved					IMMED	Reserved		
2	(MSB)	LOGICAL BLOCK ADDRESS						(LSB)	
9									
10	(MSB)	PREFETCH LENGTH						(LSB)	
13									
14	Reserved			GROUP NUMBER					
15	CONTROL								

See the PRE-FETCH (10) command (see 5.3) for the definitions of the fields in this command.

5.5 READ (6) command

The READ (6) command (see table 26) requests that the device server read the specified logical block(s) and transfer them to the data-in buffer. Each logical block read includes user data and, if the medium is formatted with protection information enabled, protection information. Each logical block transferred includes user data but does not include protection information. The most recent data value written, or to be written if cached, in the addressed logical blocks shall be returned.

Table 26 — READ (6) command

Byte\Bit	7	6	5	4	3	2	1	0
0	OPERATION CODE (08h)							
1	Reserved			(MSB)				
2								
3	LOGICAL BLOCK ADDRESS						(LSB)	
4	TRANSFER LENGTH							
5	CONTROL							

The cache control bits (see 5.6) are not provided for this command. Direct-access block devices with cache may have values for the cache control bits that affect the READ (6) command; however, no default values are defined by this standard. If explicit control is required, the READ (10) command should be used.

See the PRE-FETCH (10) command (see 5.3) for the definition of the LOGICAL BLOCK ADDRESS field.

The TRANSFER LENGTH field specifies the number of contiguous logical blocks of data that shall be read and transferred to the data-in buffer, starting with the logical block specified by the LOGICAL BLOCK ADDRESS field. A TRANSFER LENGTH field set to zero specifies that 256 logical blocks shall be read. Any other value specifies the number of logical blocks that shall be read. If the logical block address plus the transfer length exceeds the capacity of the medium, the device server shall terminate the command with CHECK CONDITION status with the sense key set to ILLEGAL REQUEST and the additional sense code set to LOGICAL BLOCK ADDRESS OUT OF RANGE. The TRANSFER LENGTH field is constrained by the MAXIMUM TRANSFER LENGTH field in the Block Limits VPD page (see 6.4.2).

NOTE 9 - For the READ (10) command, READ (12) command, READ (16) command, and READ (32) command, a TRANSFER LENGTH field set to zero specifies that no logical blocks are read.

NOTE 10 - Although the READ (6) command is limited to addressing logical blocks up to a capacity of 1 GiB, for block lengths of 512 bytes, this command has been maintained as mandatory since some system initialization routines require that the READ (6) command be used. System initialization routines should migrate from the READ (6) command to the READ (10) command, which is capable of addressing 2 TiB with block lengths of 512 bytes, or the READ (16) command to address more than 2 TiB.

The device server shall check the protection information read from the medium before returning status for the command as described in table 27.

Table 27 — Protection information checking for READ (6)

Logical unit formatted with protection information	Shall device server transmit protection information?	Field in protection information ^e	Extended INQUIRY Data VPD page bit value ^d	If check fails ^{b c} , additional sense code
Yes	No	LOGICAL BLOCK GUARD	GRD_CHK = 1	LOGICAL BLOCK GUARD CHECK FAILED
			GRD_CHK = 0	No check performed
		LOGICAL BLOCK APPLICATION TAG	APP_CHK = 1 ^a	LOGICAL BLOCK APPLICATION TAG CHECK FAILED
			APP_CHK = 0	No check performed
		LOGICAL BLOCK REFERENCE TAG	REF_CHK = 1 ^f	LOGICAL BLOCK REFERENCE TAG CHECK FAILED
			REF_CHK = 0	No check performed
No	No protection information available to check			
<p>^a The device server checks the logical block application tag only if it has knowledge of the contents of the LOGICAL BLOCK APPLICATION TAG field. The method for acquiring this knowledge is not defined by this standard.</p> <p>^b If an error is reported, the sense key shall be set to ABORTED COMMAND.</p> <p>^c If multiple errors occur, the selection of which error to report is not defined by this standard.</p> <p>^d See the Extended INQUIRY Data VPD page (see SPC-4) for the definitions of the GRD_CHK bit, APP_CHK bit, and REF_CHK bit.</p> <p>^e If the device server detects a LOGICAL BLOCK APPLICATION TAG field set to FFFFh, it shall not check any protection information in the associated logical block.</p> <p>^f If the RTO_EN bit is set to zero in the READ CAPACITY (16) parameter data (see 5.11), the device server checks the logical block reference tag by comparing it to the lower 4 bytes of the LBA associated with the logical block. If the RTO_EN bit is set to one, the device server checks the logical block reference tag only if it has knowledge of the contents of the LOGICAL BLOCK REFERENCE TAG field. The method for acquiring this knowledge is not defined by this standard.</p>				

5.6 READ (10) command

The READ (10) command (see table 28) requests that the device server read the specified logical block(s) and transfer them to the data-in buffer. Each logical block read includes user data and, if the medium is formatted with protection information enabled, protection information. Each logical block transferred includes

user data and may include protection information, based on the RDPROTECT field and the medium format. The most recent data value written in the addressed logical block shall be returned.

Table 28 — READ (10) command

Byte\Bit	7	6	5	4	3	2	1	0
0	OPERATION CODE (28h)							
1	RDPROTECT		DPO		FUA	Reserved	FUA_NV	Obsolete
2	(MSB) _____ LOGICAL BLOCK ADDRESS _____ (LSB)							
5	_____ (LSB)							
6	Reserved			GROUP NUMBER				
7	(MSB) _____ TRANSFER LENGTH _____ (LSB)							
8	_____ (LSB)							
9	CONTROL							

See the PRE-FETCH (10) command (see 5.3) for the definition of the LOGICAL BLOCK ADDRESS field.

See the PRE-FETCH (10) command (see 5.3) and 4.17 for the definition of the GROUP NUMBER field.

The device server shall check the protection information read from the medium before returning status for the command based on the RDPROTECT field as described in table 29.

Table 29 — RDPROTECT field (part 1 of 3)

Code	Logical unit formatted with protection information	Shall device server transmit protection information?	Field in protection information ^h	Extended INQUIRY Data VPD page bit value ^g	If check fails ^{d f} , additional sense code
000b ⁱ	Yes	No	LOGICAL BLOCK GUARD	GRD_CHK = 1	LOGICAL BLOCK GUARD CHECK FAILED
				GRD_CHK = 0	No check performed
			LOGICAL BLOCK APPLICATION TAG	APP_CHK = 1 ^c	LOGICAL BLOCK APPLICATION TAG CHECK FAILED
				APP_CHK = 0	No check performed
			LOGICAL BLOCK REFERENCE TAG	REF_CHK = 1 ^j	LOGICAL BLOCK REFERENCE TAG CHECK FAILED
				REF_CHK = 0	No check performed
No	No protection information available to check				

Table 29 — RDPROTECT field (part 2 of 3)

Code	Logical unit formatted with protection information	Shall device server transmit protection information?	Field in protection information ^h	Extended INQUIRY Data VPD page bit value ^g	If check fails ^{d f} , additional sense code
001b ^{b i}	Yes	Yes ^e	LOGICAL BLOCK GUARD	GRD_CHK = 1	LOGICAL BLOCK GUARD CHECK FAILED
				GRD_CHK = 0	No check performed
			LOGICAL BLOCK APPLICATION TAG	APP_CHK = 1 ^c	LOGICAL BLOCK APPLICATION TAG CHECK FAILED
				APP_CHK = 0	No check performed
			LOGICAL BLOCK REFERENCE TAG	REF_CHK = 1 ^j	LOGICAL BLOCK REFERENCE TAG CHECK FAILED
				REF_CHK = 0	No check performed
No ^a	No protection information available to transmit to the data-in buffer or for checking				
010b ^{b i}	Yes	Yes ^e	LOGICAL BLOCK GUARD	No check performed	
				LOGICAL BLOCK APPLICATION TAG	APP_CHK = 1 ^c
			APP_CHK = 0		No check performed
			LOGICAL BLOCK REFERENCE TAG	REF_CHK = 1 ^j	LOGICAL BLOCK REFERENCE TAG CHECK FAILED
				REF_CHK = 0	No check performed
			No ^a	No protection information available to transmit to the data-in buffer or for checking	
011b ^{b i}	Yes	Yes ^e	LOGICAL BLOCK GUARD	No check performed	
			LOGICAL BLOCK APPLICATION TAG	No check performed	
			LOGICAL BLOCK REFERENCE TAG	No check performed	
	No ^a	No protection information available to transmit to the data-in buffer or for checking			

Table 29 — RDPROTECT field (part 3 of 3)

Code	Logical unit formatted with protection information	Shall device server transmit protection information?	Field in protection information ^h	Extended INQUIRY Data VPD page bit value ^g	If check fails ^{d f} , additional sense code
100b ^{b i}	Yes	Yes ^e	LOGICAL BLOCK GUARD	GRD_CHK = 1	LOGICAL BLOCK GUARD CHECK FAILED
				GRD_CHK = 0	No check performed
			LOGICAL BLOCK APPLICATION TAG	No check performed	
		LOGICAL BLOCK REFERENCE TAG	No check performed		
	No ^a	No protection information available to transmit to the data-in buffer or for checking			
101b - 111b	Reserved				

^a A read operation to a logical unit that supports protection information (see 4.16) and has not been formatted with protection information shall be terminated with CHECK CONDITION status with the sense key set to ILLEGAL REQUEST and the additional sense code set to INVALID FIELD IN CDB.

^b If the logical unit does not support protection information the requested command should be terminated with CHECK CONDITION status with the sense key set to ILLEGAL REQUEST and the additional sense code set to INVALID FIELD IN CDB.

^c The device server shall check the logical block application tag if it has knowledge of the contents of the LOGICAL BLOCK APPLICATION TAG field. If the READ (32) command (see 5.9) is used and the ATO bit is set to one in the Control mode page (see SPC-4), this knowledge is acquired from the EXPECTED LOGICAL BLOCK APPLICATION TAG field and the LOGICAL BLOCK APPLICATION TAG MASK field in the CDB. Otherwise, this knowledge may be acquired by a method not defined by this standard.

^d If an error is reported, the sense key shall be set to ABORTED COMMAND.

^e Transmit protection information to the data-in buffer.

^f If multiple errors occur, the selection of which error to report is not defined by this standard.

^g See the Extended INQUIRY Data VPD page (see SPC-4) for the definitions of the GRD_CHK bit, the APP_CHK bit, and the REF_CHK bit.

^h If the application client or device server detects a LOGICAL BLOCK APPLICATION TAG field set to FFFFh, the checking of all protection information in the associated logical block shall be disabled.

ⁱ If the RTO_EN bit is set to zero in the READ CAPACITY (16) parameter data (see 5.11), the device server may process the command. If the RTO_EN bit is set to one, READ (10) commands, READ (12) commands, and READ (16) commands with the RDPROTECT field set to 000b may be processed by the device server. If the RTO_EN bit is set to one, the device server shall terminate READ (10) commands, READ (12) commands, and READ (16) commands with the RDPROTECT field not set to 000b with CHECK CONDITION status with the sense key set to ILLEGAL REQUEST and the additional sense code set to INVALID COMMAND OPERATION CODE.

^j If the RTO_EN bit is set to zero in the READ CAPACITY (16) parameter data (see 5.11), the device server checks the logical block reference tag by comparing it to the lower 4 bytes of the LBA associated with the logical block. If the RTO_EN bit is set to one (i.e., the command is a READ (32) command), the device server checks the logical block reference tag based on the EXPECTED INITIAL LOGICAL BLOCK REFERENCE TAG field in the CDB (see 4.16.2).

A disable page out (DPO) bit set to zero specifies that the retention priority shall be determined by the RETENTION PRIORITY fields in the Caching mode page (see 6.3.4). A DPO bit set to one specifies that the device

server shall assign the logical blocks accessed by this command the lowest retention priority for being fetched into or retained by the cache. A DPO bit set to one overrides any retention priority specified in the Caching mode page. All other aspects of the algorithm implementing the cache replacement strategy are not defined by this standard.

NOTE 11 - The DPO bit is used to control replacement of logical blocks in the cache when the application client has information on the future usage of the logical blocks. If the DPO bit is set to one, the application client is specifying that the logical blocks accessed by the command are not likely to be accessed again in the near future and should not be put in the cache nor retained by the cache. If the DPO bit is set to zero, the application client is specifying that the logical blocks accessed by this command are likely to be accessed again in the near future.

The force unit access (FUA) and force unit access non-volatile cache (FUA_NV) bits are defined in table 30.

Table 30 — Force unit access for read operations

FUA	FUA_NV	Description
0	0	The device server may read the logical blocks from volatile cache, non-volatile cache, and/or the medium.
0	1	<p>If the NV_SUP bit is set to one in the Extended INQUIRY Data VPD page (see SPC-4), the device server shall read the logical blocks from non-volatile cache or the medium. If a non-volatile cache is present and a volatile cache contains a more recent version of a logical block, the device server shall write the logical block to:</p> <ul style="list-style-type: none"> a) non-volatile cache; and/or b) the medium, <p>before reading it.</p> <p>If the NV_SUP bit is set to zero in the Extended INQUIRY Data VPD page (see SPC-4), the device server may read the logical blocks from volatile cache, non-volatile cache, and/or the medium.</p>
1	0 or 1	The device server shall read the logical blocks from the medium. If a cache contains a more recent version of a logical block, the device server shall write the logical block to the medium before reading it.

The TRANSFER LENGTH field specifies the number of contiguous logical blocks of data that shall be read and transferred to the data-in buffer, starting with the logical block specified by the LOGICAL BLOCK ADDRESS field. A TRANSFER LENGTH field set to zero specifies that no logical blocks shall be read. This condition shall not be considered an error. Any other value specifies the number of logical blocks that shall be read. If the logical block address plus the transfer length exceeds the capacity of the medium, the device server shall terminate the command with CHECK CONDITION status with the sense key set to ILLEGAL REQUEST and the additional sense code set to LOGICAL BLOCK ADDRESS OUT OF RANGE. The TRANSFER LENGTH field is constrained by the MAXIMUM TRANSFER LENGTH field in the Block Limits VPD page (see 6.4.2).

NOTE 12 - For the READ (6) command, a TRANSFER LENGTH field set to zero specifies that 256 logical blocks are read.

5.7 READ (12) command

The READ (12) command (see table 31) requests that the device server read the specified logical block(s) and transfer them to the data-in buffer. Each logical block read includes user data and, if the medium is

formatted with protection information enabled, protection information. Each logical block transferred includes user data and may include protection information, based on the RDPROTECT field and the medium format.

Table 31 — READ (12) command

Byte\Bit	7	6	5	4	3	2	1	0
0	OPERATION CODE (A8h)							
1	RDPROTECT			DPO	FUA	Reserved	FUA_NV	Obsolete
2	(MSB)	LOGICAL BLOCK ADDRESS						(LSB)
5								
6	(MSB)	TRANSFER LENGTH						(LSB)
9								
10	Restricted for MMC-4	Reserved		GROUP NUMBER				
11	CONTROL							

See the READ (10) command (see 5.6) for the definitions of the fields in this command.

5.8 READ (16) command

The READ (16) command (see table 32) requests that the device server read the specified logical block(s) and transfer them to the data-in buffer. Each logical block read includes user data and, if the medium is formatted with protection information enabled, protection information. Each logical block transferred includes user data and may include protection information, based on the RDPROTECT field and the medium format.

Table 32 — READ (16) command

Byte\Bit	7	6	5	4	3	2	1	0
0	OPERATION CODE (88h)							
1	RDPROTECT			DPO	FUA	Reserved	FUA_NV	Reserved
2	(MSB)	LOGICAL BLOCK ADDRESS						(LSB)
9								
10	(MSB)	TRANSFER LENGTH						(LSB)
13								
14	Restricted for MMC-4	Reserved		GROUP NUMBER				
15	CONTROL							

See the READ (10) command (see 5.6) for the definitions of the fields in this command.

5.9 READ (32) command

The READ (32) command (see table 33) requests that the device server read the specified logical block(s) and transfer them to the data-in buffer. Each logical block read includes user data and, if the medium is formatted with protection information enabled, protection information. Each logical block transferred includes user data and may include protection information, based on the RDPROTECT field and the medium format.

If the RTO_EN bit is set to zero in the READ CAPACITY (16) parameter data (see 5.11), the device server shall terminate the command with CHECK CONDITION status with the sense key set to ILLEGAL REQUEST and the additional sense code set to INVALID COMMAND OPERATION CODE. If the RTO_EN bit is set to one, the device server may process the command.

Table 33 — READ (32) command

Byte/Bit	7	6	5	4	3	2	1	0
0	OPERATION CODE (7Fh)							
1	CONTROL							
2	Reserved							
5	Reserved							
6	Reserved			GROUP NUMBER				
7	ADDITIONAL CDB LENGTH (18h)							
8	(MSB)	SERVICE ACTION (0009h)						(LSB)
9								
10	RDPROTECT			DPO	FUA	Reserved	FUA_NV	Reserved
11	Reserved							
12	(MSB)	LOGICAL BLOCK ADDRESS						(LSB)
19								
20	(MSB)	EXPECTED INITIAL LOGICAL BLOCK REFERENCE TAG						(LSB)
23								
24	(MSB)	EXPECTED LOGICAL BLOCK APPLICATION TAG						(LSB)
25								
26	(MSB)	LOGICAL BLOCK APPLICATION TAG MASK						(LSB)
27								
28	(MSB)	TRANSFER LENGTH						(LSB)
31								

See the READ (10) command (see 5.6) for the definitions of the GROUP NUMBER field, the RDPROTECT field, the DPO bit, the FUA bit, the FUA_NV bit, the LOGICAL BLOCK ADDRESS field, and the TRANSFER LENGTH field.

When checking of the LOGICAL BLOCK REFERENCE TAG field is enabled (see table 29 in 5.6), the EXPECTED INITIAL LOGICAL BLOCK REFERENCE TAG field contains the value of the LOGICAL BLOCK REFERENCE TAG field expected in the protection information of the first logical block accessed by the command instead of a value based on the LBA (see 4.16.2).

If the ATO bit is set to one in the Control mode page (see SPC-4) and checking of the LOGICAL BLOCK APPLICATION TAG field is enabled (see table 29 in 5.6), the LOGICAL BLOCK APPLICATION TAG MASK field contains a value that is a bit mask for enabling the checking of the LOGICAL BLOCK APPLICATION TAG field in the protection information for each logical block accessed by the command. A LOGICAL BLOCK APPLICATION TAG MASK field bit set to one enables the checking of the corresponding bit of the EXPECTED LOGICAL BLOCK APPLICATION TAG field with the corresponding bit of the LOGICAL BLOCK APPLICATION TAG field in the protection information.

If the ATO bit is set to one in the Control mode page (see SPC-4) and checking of the LOGICAL BLOCK APPLICATION TAG field is disabled (see table 29 in 5.6), or if the ATO bit is set to zero, the LOGICAL BLOCK APPLICATION TAG MASK field and the EXPECTED LOGICAL BLOCK APPLICATION TAG field shall be ignored.

5.10 READ CAPACITY (10) command

5.10.1 READ CAPACITY (10) overview

The READ CAPACITY (10) command (see table 34) requests that the device server transfer 8 bytes of parameter data describing the capacity and medium format of the direct-access block device to the data-in buffer. This command may be processed as if it has a HEAD OF QUEUE task attribute (see 4.11). If the logical unit supports protection information (see 4.16), the application client should use the READ CAPACITY (16) command instead of the READ CAPACITY (10) command.

Table 34 — READ CAPACITY (10) command

Byte\Bit	7	6	5	4	3	2	1	0	
0	OPERATION CODE (25h)								
1	Reserved							Obsolete	
2	(MSB)	LOGICAL BLOCK ADDRESS						(LSB)	
5									
6	Reserved								
7									
8	Reserved							PMI	
9	CONTROL								

See the PRE-FETCH (10) command (see 5.3) for the definition of the LOGICAL BLOCK ADDRESS field.

The LOGICAL BLOCK ADDRESS field shall be set to zero if the PMI bit is set to zero. If the PMI bit is set to zero and the LOGICAL BLOCK ADDRESS field is not set to zero, the device server shall terminate the command with CHECK CONDITION status with the sense key set to ILLEGAL REQUEST and the additional sense code set to INVALID FIELD IN CDB.

A partial medium indicator (PMI) bit set to zero specifies that the device server return information on the last logical block on the direct-access block device.

A PMI bit set to one specifies that the device server return information on the last logical block after that specified in the LOGICAL BLOCK ADDRESS field before a substantial vendor-specific delay in data transfer may be encountered.

NOTE 13 - This function is intended to assist storage management software in determining whether there is sufficient space starting with the logical block address specified in the CDB to contain a frequently accessed data structure (e.g., a file directory or file index) without incurring an extra delay.

5.10.2 READ CAPACITY (10) parameter data

The READ CAPACITY (10) parameter data is defined in table 35. Any time the READ CAPACITY (10) parameter data changes, the device server should establish a unit attention condition as described in 4.6.

Table 35 — READ CAPACITY (10) parameter data

Byte\Bit	7	6	5	4	3	2	1	0	
0	(MSB)	RETURNED LOGICAL BLOCK ADDRESS						(LSB)	
3									
4	(MSB)	BLOCK LENGTH IN BYTES						(LSB)	
7									

If the number of logical blocks exceeds the maximum value that is able to be specified in the RETURNED LOGICAL BLOCK ADDRESS field, the device server shall set the RETURNED LOGICAL BLOCK ADDRESS field to FFFFFFFh. The application client should then issue a READ CAPACITY (16) command (see 5.11) to retrieve the READ CAPACITY (16) parameter data.

If the PMI bit is set to zero, the device server shall set the RETURNED LOGICAL BLOCK ADDRESS field to the lower of:

- a) the LBA of the last logical block on the direct-access block device; or
- b) FFFFFFFh.

If the PMI bit is set to one, the device server shall set the RETURNED LOGICAL BLOCK ADDRESS field to the lower of:

- a) the last LBA after that specified in the LOGICAL BLOCK ADDRESS field of the CDB before a substantial vendor-specific delay in data transfer may be encountered; or
- b) FFFFFFFh.

The RETURNED LOGICAL BLOCK ADDRESS shall be greater than or equal to that specified by the LOGICAL BLOCK ADDRESS field in the CDB.

The BLOCK LENGTH IN BYTES field contains the number of bytes of user data in the logical block indicated by the RETURNED LOGICAL BLOCK ADDRESS field. This value does not include protection information or additional information (e.g., ECC bytes) recorded on the medium.

5.11 READ CAPACITY (16) command

5.11.1 READ CAPACITY (16) command overview

The READ CAPACITY (16) command (see table 36) requests that the device server transfer parameter data describing the capacity and medium format of the direct-access block device to the data-in buffer. This command is mandatory if the logical unit supports protection information (see 4.16) and optional otherwise. This command is implemented as a service action of the SERVICE ACTION IN operation code (see A.2). This command may be processed as if it has a HEAD OF QUEUE task attribute (see 4.11).

Table 36 — READ CAPACITY (16) command

Byte/Bit	7	6	5	4	3	2	1	0
0	OPERATION CODE (9Eh)							
1	Reserved			SERVICE ACTION (10h)				
2	(MSB) LOGICAL BLOCK ADDRESS (LSB)							
9								
10	(MSB) ALLOCATION LENGTH (LSB)							
13								
14	Reserved							PMI
15	CONTROL							

See the READ CAPACITY (10) command (see 5.10) for definitions of the LOGICAL BLOCK ADDRESS field and the PMI bit.

The ALLOCATION LENGTH field specifies the maximum number of bytes that the application client has allocated for returned parameter data. An allocation length of zero indicates that no data shall be transferred. This condition shall not be considered as an error. The device server shall terminate transfers to the data-in buffer when the number of bytes specified by the ALLOCATION LENGTH field have been transferred or when all available data has been transferred, whichever is less. The contents of the parameter data shall not be altered to reflect the truncation, if any, that results from an insufficient allocation length.

5.11.2 READ CAPACITY (16) parameter data

The READ CAPACITY (16) parameter data is defined in table 37. Any time the READ CAPACITY (16) parameter data changes, the device server should establish a unit attention condition as described in 4.6.

Table 37 — READ CAPACITY (16) parameter data

Byte\Bit	7	6	5	4	3	2	1	0
0	(MSB) RETURNED LOGICAL BLOCK ADDRESS							
7	(LSB)							
8	(MSB) BLOCK LENGTH IN BYTES							
11	(LSB)							
12	Reserved					RTO_EN	PROT_EN	
13	Reserved							
31	Reserved							

The RETURNED LOGICAL BLOCK ADDRESS field and BLOCK LENGTH IN BYTES field of the READ CAPACITY (16) parameter data are the same as the in the READ CAPACITY (10) parameter data (see 5.10). The maximum value that shall be returned in the RETURNED LOGICAL BLOCK ADDRESS field is FFFFFFFF_FFFFFFFEh.

A reference tag own enable (RTO_EN) bit set to one indicates that application client ownership of the LOGICAL BLOCK REFERENCE TAG field in protection information is enabled (i.e., the medium was formatted with protection information (see 4.16) enabled and the RTO_REQ bit was set to one). An RTO_EN bit set to zero indicates that application client ownership of the LOGICAL BLOCK REFERENCE TAG field in protection information is disabled.

A PROT_EN bit set to one indicates that the medium was formatted with protection information (see 4.16) enabled. A PROT_EN bit set to zero indicates that the medium was not formatted with protection information enabled.

5.12 READ DEFECT DATA (10) command

5.12.1 READ DEFECT DATA (10) command overview

The READ DEFECT DATA (10) command (see table 38) requests that the device server transfer the medium defect data to the data-in buffer.

Table 38 — READ DEFECT DATA (10) command

Byte\Bit	7	6	5	4	3	2	1	0
0	OPERATION CODE (37h)							
1	Reserved							
2	Reserved			REQ_PLIST	REQ_GLIST	DEFECT LIST FORMAT		
3	Reserved							
6	Reserved							
7	(MSB) ALLOCATION LENGTH							
8	(LSB)							
9	CONTROL							

If the device server is unable to access the medium defect data, it shall terminate the command with CHECK CONDITION status. The sense key shall be set to either MEDIUM ERROR, if a medium error occurred, or NO

SENSE, if medium defect data does not exist. The additional sense code shall be set to DEFECT LIST NOT FOUND.

NOTE 14 - Some device servers may not be able to return medium defect data until after a FORMAT UNIT command (see 5.2) has been completed successfully.

A request primary defect list (REQ_PLIST) bit set to zero specifies that the device server shall not return the PLIST. A REQ_PLIST bit set to one specifies that the device server shall return the PLIST, if any.

A request grown defect list (REQ_GLIST) bit set to zero specifies that the device server shall not return the GLIST. A REQ_GLIST bit set to one specifies that the device server shall return the GLIST, if any.

A REQ_PLIST bit set to zero and a REQ_GLIST bit set to zero specifies that the device server shall return only the defect list header (i.e., the first four bytes of the defect list).

A REQ_PLIST bit set to one and a REQ_GLIST bit set to one specifies that the device server shall return both the PLIST and GLIST, if any. The order the lists are returned in is vendor-specific. Whether the lists are merged or not is vendor-specific.

The DEFECT LIST FORMAT field specifies the preferred format for the defect list. This field is intended for those device servers capable of returning more than one format, as defined in the FORMAT UNIT command (see 5.2.2.4). A device server unable to return the requested format shall return the defect list in its default format and indicate that format in the DEFECT LIST FORMAT field in the defect list header (see table 39).

If the requested defect list format and the returned defect list format are not the same, the device server shall transfer the defect data and then terminate the command with CHECK CONDITION status with the sense key set to RECOVERED ERROR and the additional sense code set to DEFECT LIST NOT FOUND.

The ALLOCATION LENGTH field is defined in the READ CAPACITY (16) command (see 5.11). The application client is responsible for comparing the allocation length requested in the CDB with the defect list length returned in the parameter data to determine whether a partial list was received. If the number of address descriptors the device server has to report exceeds the maximum value that is able to be specified in the ALLOCATION LENGTH field, the device server shall transfer no data and return CHECK CONDITION status with the sense key set to ILLEGAL REQUEST and the additional sense code set to INVALID FIELD IN CDB.

5.12.2 READ DEFECT DATA (10) parameter data

The READ DEFECT DATA (10) parameter data (see table 39) contains a four-byte header, followed by zero or more address descriptors.

Table 39 — READ DEFECT DATA (10) parameter data

Byte\Bit	7	6	5	4	3	2	1	0	
0	Reserved								
1	Reserved			PLISTV	GLISTV	DEFECT LIST FORMAT			
2	(MSB)	DEFECT LIST LENGTH (n - 3)							
3								(LSB)	
Defect list (if any)									
4	Address descriptor(s) (if any)								
n									

A PLIST valid (PLISTV) bit set to zero indicates that the data returned does not contain the PLIST. A PLISTV bit set to one indicates that the data returned contains the PLIST.

A GLIST valid (GLISTV) bit set to zero indicates that the data returned does not contain the GLIST. A GLISTV bit set to one indicates that the data returned contains the GLIST.

The DEFECT LIST FORMAT field indicates the format of the address descriptors returned by the device server. This field is defined in the FORMAT UNIT command (see 5.2.2.4).

If the device server returns short block format address descriptors (see 5.2.2.4.2) or long block format address descriptors (see 5.2.2.4.3), the address descriptors contain vendor-specific values.

NOTE 15 - The use of the short block format and the long block format is not recommended for this command. There is no standard model that defines the meaning of the block address of a defect. In the usual case, a defect that has been reassigned no longer has an LBA.

If the device server returns physical sector format address descriptors (see 5.2.2.4.5), it may or may not include defects in parts of the medium not accessible to the application client. If the device server returns bytes from index format address descriptors (see 5.2.2.4.4), it shall return a complete list of the defects. A complete list of the defects may include defects in areas not within the capacity returned in the READ CAPACITY command.

The DEFECT LIST LENGTH field indicates the length in bytes of the address descriptors that follow. The DEFECT LIST LENGTH is equal to four or eight times the number of the address descriptors, depending on the format of the returned address descriptors (see 5.2.2.4).

The address descriptors may or may not be sent in ascending order.

5.13 READ DEFECT DATA (12) command

5.13.1 READ DEFECT DATA (12) command overview

The READ DEFECT DATA (12) command (see table 40) requests that the device server transfer the medium defect data to the data-in buffer.

Table 40 — READ DEFECT DATA (12) command

Byte\Bit	7	6	5	4	3	2	1	0
0	OPERATION CODE (B7h)							
1	Reserved			REQ_PLIST	REQ_GLIST	DEFECT LIST FORMAT		
2	Reserved							
5	Reserved							
6	(MSB)	ALLOCATION LENGTH						(LSB)
9	Reserved							
10	Reserved							
11	CONTROL							

See the READ DEFECT DATA (10) command (see 5.11) for the definitions of the fields in this command.

NOTE 16 - The application client may determine the length of the defect list by sending the READ DEFECT DATA (12) command with an ALLOCATION LENGTH field set to eight. The device server returns the defect list header that contains the length of the defect list.

5.13.2 READ DEFECT DATA (12) parameter data

The READ DEFECT DATA (12) parameter data (see table 41) contains an eight byte header, followed by zero or more address descriptors.

Table 41 — READ DEFECT DATA (12) parameter data

Byte\Bit	7	6	5	4	3	2	1	0
0	Reserved							
1	Reserved			PLISTV	GLISTV	DEFECT LIST FORMAT		
2	Reserved							
3	Reserved							
4	(MSB)	DEFECT LIST LENGTH (n - 7)						(LSB)
7								
Defect list (if any)								
8	Address descriptor(s) (if any)							
n								

See the READ DEFECT DATA (10) command (see 5.12) for the definitions of the fields in the defect list.

5.14 READ LONG (10) command

The READ LONG (10) command (see table 42) requests that the device server transfer data from a single logical block to the data-in buffer. The data transferred during the READ LONG (10) command is vendor-specific, but shall include the following items recorded on the medium:

- a) user data or transformed user data;
- b) protection information or transformed protection information, if any; and
- c) any additional information (e.g., ECC bytes).

If a cache contains a more recent version of a logical block, the device server shall write the logical block to the medium before reading it. The values in the Read-Write Error Recovery mode page (see 6.3.5) do not apply to this command. The device server may perform retries while processing this command.

Table 42 — READ LONG (10) command

Byte\Bit	7	6	5	4	3	2	1	0
0	OPERATION CODE (3Eh)							
1	Reserved						CORRCT	Obsolete
2	(MSB)	LOGICAL BLOCK ADDRESS						(LSB)
5								
6	Reserved							
7	(MSB)	BYTE TRANSFER LENGTH						(LSB)
8								
9	CONTROL							

See the PRE-FETCH (10) command (see 5.3) for the definition of the LOGICAL BLOCK ADDRESS field.

If the additional information contain an ECC, any other additional bytes that are correctable by ECC should be included (e.g., a data synchronization mark within the area covered by ECC). It is not required for the ECC

bytes to be at the end of the user data or protection information, if any; however, the ECC bytes should be in the same order as they are on the medium.

A correct (CORRECT) bit set to zero specifies that a logical block be read without any correction made by the device server. A CORRECT bit set to one should result in GOOD status unless data is not transferred for some reason other than that the data is non-correctable. In this case the appropriate status and sense data shall be returned. A CORRECT bit set to one specifies that the data be corrected by ECC before being transferred to the data-in buffer.

The BYTE TRANSFER LENGTH field specifies the number of bytes of data that shall be read from the specified logical block and transferred to the data-in buffer. If the BYTE TRANSFER LENGTH field is not set to zero and does not match the available data length, the device server shall terminate the command with CHECK CONDITION status with the sense key set to ILLEGAL REQUEST and the additional sense code set to INVALID FIELD IN CDB. In the sense data (see 4.13 and SPC-4), the VALID and ILI bits shall each be set to one and the INFORMATION field shall be set to the difference (i.e., residue) of the requested byte transfer length minus the actual available data length in bytes. Negative values shall be indicated by two's complement notation.

A BYTE TRANSFER LENGTH field set to zero specifies that no bytes shall be read. This condition shall not be considered an error.

5.15 READ LONG (16) command

The READ LONG (16) command (see table 43) requests that the device server transfer data from a single logical block to the data-in buffer. The data transferred during the READ LONG (16) command is vendor-specific, but shall include the following items recorded on the medium:

- a) user data or transformed user data;
- b) protection information or transformed protection information, if any; and
- c) any additional information (e.g., ECC bytes).

If a cache contains a more recent version of a logical block, the device server shall write the logical block to the medium before reading it. The values in the Read-Write Error Recovery mode page (see 6.3.5) do not apply to this command. The device server may perform retries while processing this command. This command is implemented as a service action of the SERVICE ACTION IN operation code (see A.2).

Table 43 — READ LONG (16) command

Byte/Bit	7	6	5	4	3	2	1	0
0	OPERATION CODE (9Eh)							
1	Reserved			SERVICE ACTION (11h)				
2	(MSB) LOGICAL BLOCK ADDRESS (LSB)							
9								
10	Reserved							
11								
12	(MSB) BYTE TRANSFER LENGTH (LSB)							
13								
14	Reserved							CORRECT
15	CONTROL							

See the READ LONG (10) command (see 5.14) for the definitions of the fields in this command.

5.16 REASSIGN BLOCKS command

5.16.1 REASSIGN BLOCKS command overview

The REASSIGN BLOCKS command (see table 44) requests that the device server reassign defective logical blocks to another area on the medium set aside for this purpose. The device server should also record the location of the defective logical blocks in the GLIST, if supported. This command shall not alter the contents of the PLIST (see 4.8).

The parameter list provided in the data-out buffer contains a defective LBA list that contains the LBAs of the logical blocks to be reassigned. The device server shall reassign the parts of the medium used for each logical block in the defective LBA list. More than one physical block may be relocated by each LBA. If the device server is able to recover user data and protection information, if any, from the original logical block, it shall write the recovered user data and any protection information to the reassigned logical block. If the device server is unable to recover user data and protection information, if any, it shall write vendor-specific data as the user data and shall write a default value of FFFFFFFF_FFFFFFFFh as the protection information, if enabled. The data in all other logical blocks on the medium shall be preserved.

NOTE 17 - The effect of specifying a logical block to be reassigned that previously has been reassigned is to reassign the logical block again. Although not likely, over the life of the medium, a logical block may be assigned to multiple physical block addresses until no more spare locations remain on the medium.

Table 44 — REASSIGN BLOCKS command

Byte\Bit	7	6	5	4	3	2	1	0
0	OPERATION CODE (07h)							
1	Reserved						LONGLBA	ONGLIST
2	Reserved							
4	Reserved							
5	CONTROL							

A long LBA (LONGLBA) bit set to zero specifies that the REASSIGN BLOCKS defective LBA list contains four byte LBAs. A LONGLBA bit set to one specifies that the REASSIGN BLOCKS defective LBA list contains eight byte LBAs.

5.16.2 REASSIGN BLOCKS parameter list

The REASSIGN BLOCKS parameter list (see table 45) contains a four-byte parameter list header followed by a defective LBA list containing one or more LBAs.

Table 45 — REASSIGN BLOCKS parameter list

Byte\Bit	7	6	5	4	3	2	1	0
0	Parameter list header (see table 46 or table 47)							
3	Parameter list header (see table 46 or table 47)							
4	DEFECTIVE LBA LIST (if any)							
n	DEFECTIVE LBA LIST (if any)							

If **LONGLIST** is set to zero, the parameter list header is defined in table 46.

Table 46 — REASSIGN BLOCKS short parameter list header

Byte\Bit	7	6	5	4	3	2	1	0	
0	Reserved								
1	Reserved								
2	(MSB)	DEFECT LIST LENGTH							
3								(LSB)	

If **LONGLIST** is set to one, the parameter list header is defined in table 47.

Table 47 — REASSIGN BLOCKS long parameter list header

Byte\Bit	7	6	5	4	3	2	1	0	
0	(MSB)	DEFECT LIST LENGTH							
3								(LSB)	

The **DEFECT LIST LENGTH** field indicates the total length in bytes of the **DEFECTIVE LBA LIST** field. The **DEFECT LIST LENGTH** field does not include the parameter list header length and is equal to either:

- a) four times the number of LBAs, if the **LONGLBA** bit is set to zero; or
- b) eight times the number of LBAs, if the **LONGLBA** bit is set to one.

The **DEFECTIVE LBA LIST** field contains a list of defective LBAs. Each LBA is a four-byte field if the **LONGLBA** bit is set to zero or an eight-byte field if the **LONGLBA** bit is set to one. The LBAs shall be in ascending order.

If the direct-access block device has insufficient capacity to reassign all of the specified logical blocks, the device server shall terminate the command with **CHECK CONDITION** status with the sense key set to **HARDWARE ERROR** and the additional sense code set to **NO DEFECT SPARE LOCATION AVAILABLE**.

If the direct-access block device is unable to successfully complete a **REASSIGN BLOCKS** command, the device server shall terminate the command with **CHECK CONDITION** status with the appropriate sense data (see 4.13 and SPC-4). The first LBA not reassigned shall be returned in the **COMMAND-SPECIFIC INFORMATION** field of the sense data. If information about the first LBA not reassigned is not available, or if all the defects have been reassigned, the **COMMAND-SPECIFIC INFORMATION** field shall be set to **FFFFFFFFh** if fixed format sense data is being used or **FFFFFFFF_FFFFFFFFh** if descriptor format sense data is being used.

If the **REASSIGN BLOCKS** command failed due to an unexpected unrecoverable read error that would cause the loss of data in a logical block not specified in the defective LBA list, the LBA of the unrecoverable block shall be returned in the **INFORMATION** field of the sense data and the **VALID** bit shall be set to one.

NOTE 18 - If the **REASSIGN BLOCKS** command returns **CHECK CONDITION** status and the sense data **COMMAND-SPECIFIC INFORMATION** field contains a valid LBA, the application client should remove all LBAs from the defective LBA list prior to the one returned in the **COMMAND-SPECIFIC INFORMATION** field. If the sense key is **MEDIUM ERROR** and the **INFORMATION** field contains the valid LBA, the application client should insert that new defective LBA into the defective LBA list and reissue the **REASSIGN BLOCKS** command with the new defective LBA list. Otherwise, the application client should perform any corrective action indicated by the sense data and then reissue the **REASSIGN BLOCKS** command with the new defective LBA list.

5.17 START STOP UNIT command

The **START STOP UNIT** command (see table 48) requests that the device server change the power condition of the logical unit (see 4.15) or load or eject the medium. This includes specifying that the device server enable or disable the direct-access block device for medium access operations by controlling power conditions and timers.

Logical units that contain cache shall write all cached logical blocks to the medium (e.g., as they would do in response to a SYNCHRONIZE CACHE command (see 5.18 and 5.19) with the SYNC_NV bit set to zero, the LOGICAL BLOCK ADDRESS field set to zero, and the NUMBER OF BLOCKS field set to zero) prior to entering into any power condition that prevents accessing the medium (e.g., before the rotating media spindle motor is stopped during transition to the stopped power condition).

Table 48 — START STOP UNIT command

Byte\Bit	7	6	5	4	3	2	1	0
0	OPERATION CODE (1Bh)							
1	Reserved							IMMED
2	Reserved							
3	Reserved							
4	POWER CONDITION				Reserved		LOEJ	START
5	CONTROL							

If the immediate (IMMED) bit is set to zero, then the device server shall return status after the operation is completed. If the IMMED bit set to one, then the device server shall return status as soon as the CDB has been validated.

The POWER CONDITION field is used to specify that the logical unit be placed into a power condition or to adjust a timer as defined in table 49. If this field is supported and is set to a value other than 0h, then the START and LOEJ bits shall be ignored.

Table 49 — POWER CONDITION field

Code	Name	Description
0h	START_VALID	Process the START and LOEJ bits.
1h	ACTIVE	Place the device into the active power condition.
2h	IDLE	Place the device into the idle power condition.
3h	STANDBY	Place the device into the standby power condition.
4h	Reserved	Reserved
5h	Obsolete	Obsolete
6h	Reserved	Reserved
7h	LU_CONTROL	Transfer control of power conditions to the logical unit.
8h - 9h	Reserved	Reserved
Ah	FORCE_IDLE_0	Force the idle condition timer to zero.
Bh	FORCE_STANDBY_0	Force the standby condition timer to zero.
Ch - Fh	Reserved	Reserved

If the START STOP UNIT command is received with the POWER CONDITION field set to ACTIVE, IDLE, or STANDBY, then:

- a) the logical unit shall transition to the specified power condition;
- b) the logical unit shall change power conditions only after receipt of another START STOP UNIT command or a logical unit reset;

- c) the device server shall disable the idle condition timer if it is active (see SPC-4) and disable the standby condition timer if it is active (see SPC-4) until another START STOP UNIT command is received that returns control of the power condition to the logical unit, or a logical unit reset occurs.

If the START STOP UNIT command is received with the POWER CONDITION field set to LU_CONTROL, then the device server shall enable the idle condition timer if it is active (see SPC-4) and disable the standby condition timer if it is active (see SPC-4).

If the START STOP UNIT command is received with the POWER CONDITION field set to FORCE_IDLE_0 or FORCE_STANDBY_0, then the device server shall:

- a) force the specified timer to zero, cause the logical unit to transition to the specified power condition, and return control of the power condition to the device server; or
- b) terminate a START STOP UNIT command that selects a timer that is not supported by the device server or a timer that is not active. The command shall be terminated with CHECK CONDITION status with the sense key set to ILLEGAL REQUEST and the additional sense code set to INVALID FIELD IN CDB.

It is not an error to specify that the logical unit transition to its current power condition.

If the load eject (LOEJ) bit is set to zero, then the logical unit shall take no action regarding loading or ejecting the medium. If the LOEJ bit is set to one, then the logical unit shall unload the medium if the START bit is set to zero. If the LOEJ bit is set to one, then the logical unit shall load the medium if the START bit is set to one.

If the START bit is set to zero, then the logical unit shall transition to the stopped power condition, disable the idle condition timer if it is active (see SPC-4), and disable the standby condition timer if it is active (see SPC-4). If the START bit set to one, then the logical unit shall transition to the active power condition, enable the idle condition timer if it is active, and enable the standby condition timer if it is active.

5.18 SYNCHRONIZE CACHE (10) command

The SYNCHRONIZE CACHE (10) command (see table 50) requests that the device server ensure that the specified logical blocks have their most recent data values recorded in non-volatile cache and/or on the medium, based on the SYNC_NV bit. Logical blocks include user data and, if the medium is formatted with protection information enabled, protection information. Logical blocks may or may not be removed from volatile cache and non-volatile cache as a result of the synchronize cache operation.

Table 50 — SYNCHRONIZE CACHE (10) command

Byte\Bit	7	6	5	4	3	2	1	0
0	OPERATION CODE (35h)							
1	Reserved					SYNC_NV	IMMED	Obsolete
2	(MSB)	LOGICAL BLOCK ADDRESS						(LSB)
5	Reserved			GROUP NUMBER				
6	(MSB)	NUMBER OF BLOCKS						(LSB)
7	CONTROL							
8								
9								

See the PRE-FETCH (10) command (see 5.3) for the definition of the LOGICAL BLOCK ADDRESS field.

See the PRE-FETCH (10) command (see 5.3) and 4.17 for the definition of the GROUP NUMBER field.

The SYNC_NV bit (see table 51) specifies whether the device server is required to synchronize volatile and non-volatile caches.

Table 51 — SYNC_NV bit

Code	Device server requirement to synchronize logical blocks currently in the	
	Volatile cache	Non-volatile cache
0	Device server shall synchronize to the medium.	Device server shall synchronize to the medium.
1	If a non-volatile cache is present, device server shall synchronize to non-volatile cache or the medium. If a non-volatile cache is not present, device server shall synchronize to the medium.	No requirement.

An immediate (IMMED) bit set to zero specifies that the device server shall not return status until the operation has been completed. An IMMED bit set to one specifies that the device server shall return status as soon as the CDB has been validated. If the IMMED bit is set to one and the device server does not support the IMMED bit, the device server shall terminate the command with CHECK CONDITION status with the sense key set to ILLEGAL REQUEST and the additional sense code set to INVALID FIELD IN CDB.

The NUMBER OF BLOCKS field specifies the number of logical blocks that shall be synchronized, starting with the logical block specified by the LOGICAL BLOCK ADDRESS field. A NUMBER OF BLOCKS field set to zero specifies that all logical blocks starting with the one specified in the LOGICAL BLOCK ADDRESS field to the last logical block on the medium shall be synchronized. If the logical block address plus the number of blocks exceeds the capacity of the medium, the device server shall terminate the command with CHECK CONDITION status with the sense key set to ILLEGAL REQUEST and the additional sense code set to LOGICAL BLOCK ADDRESS OUT OF RANGE.

A logical block within the range that is not in cache is not considered an error.

5.19 SYNCHRONIZE CACHE (16) command

The SYNCHRONIZE CACHE (16) command (see table 52) requests that the device server ensure that the specified logical blocks have their most recent data values recorded in non-volatile cache and/or on the medium, based on the SYNC_NV bit. Logical blocks include user data and, if the medium is formatted with protection information enabled, protection information. Logical blocks may or may not be removed from volatile cache and non-volatile cache as a result of the synchronize cache operation.

Table 52 — SYNCHRONIZE CACHE (16) command

Byte\Bit	7	6	5	4	3	2	1	0
0	OPERATION CODE (91h)							
1	Reserved					SYNC_NV	IMMED	Reserved
2	(MSB)	LOGICAL BLOCK ADDRESS						(LSB)
9								
10	(MSB)	NUMBER OF BLOCKS						(LSB)
13								
14	Reserved			GROUP NUMBER				
15	CONTROL							

See the SYNCHRONIZE CACHE (10) command (see 5.18) for the definitions of the fields in this command.

5.20 VERIFY (10) command

The VERIFY (10) command (see table 53) requests that the device server verify the specified logical block(s) on the medium. Each logical block includes user data and may include protection information, based on the VRPROTECT field and the medium format.

If the RTO_EN bit is set to one in the READ CAPACITY (16) parameter data (see 5.11), the device server shall terminate this command with CHECK CONDITION status with the sense key set to ILLEGAL REQUEST and the additional sense code set to INVALID COMMAND OPERATION CODE.

NOTE 19 - This command description is referenced by the VERIFY (32) command, which is terminated when the RTO_EN bit is set to zero rather than one.

Table 53 — VERIFY (10) command

Byte\Bit	7	6	5	4	3	2	1	0
0	OPERATION CODE (2Fh)							
1	VRPROTECT			DPO	Reserved		BYTCHK	Obsolete
2	(MSB) _____ LOGICAL BLOCK ADDRESS _____ (LSB)							
5								
6	Restricted for MMC-4	Reserved		GROUP NUMBER				
7	(MSB) _____ VERIFICATION LENGTH _____ (LSB)							
8								
9	CONTROL							

Logical units that contain cache shall write referenced cached logical blocks to the medium for the logical unit (e.g., as they would do in response to a SYNCHRONIZE CACHE command (see 5.18 and 5.19) with the SYNC_NV bit set to zero, the LOGICAL BLOCK ADDRESS field set to the value of the VERIFY command's LOGICAL BLOCK ADDRESS field, and the NUMBER OF BLOCKS field set to the value of the VERIFY command's VERIFICATION LENGTH field).

See the READ (10) command (see 5.6) for the definition of the DPO bit. See the PRE-FETCH (10) command (see 5.3) for the definition of the LOGICAL BLOCK ADDRESS field. See the PRE-FETCH (10) command (see 5.3) and 4.17 for the definition of the GROUP NUMBER field.

If the Verify Error Recovery mode page (see 6.3.6) is implemented, then the current settings in that page specify the verification criteria. If the Verify Error Recovery mode page is not implemented, then the verification criteria is vendor-specific.

If the byte check (BYTCHK) bit is set to zero, the device server shall:

- a) perform a medium verification with no data comparison and not transfer any data from the data-out buffer; and
- b) check protection information read from the medium based on the VRPROTECT field as described in table 54.

If the BYTCHK bit is set to one, the device server shall:

- a) perform a byte-by-byte comparison of user data read from the medium and user data transferred from the data-out buffer;
- b) check protection information read from the medium based on the VRPROTECT field as described in table 55;
- c) check protection transferred from the data-out buffer based on the VRPROTECT field as described in table 56; and
- d) perform a byte-by-byte comparison of protection information read from the medium and transferred from the data-out buffer based on the VRPROTECT field as described in table 57.

The order of the user data and protection information checks and comparisons is vendor-specific.

If a byte-by-byte comparison is unsuccessful for any reason, the device server shall terminate the command with CHECK CONDITION status with the sense key set to MISCOMPARE and the additional sense code set to the appropriate value for the condition.

The VERIFICATION LENGTH field specifies the number of contiguous logical blocks that shall be verified, starting with the logical block specified by the LOGICAL BLOCK ADDRESS field. If the BYTCHK bit is set to one, the VERIFICATION LENGTH field also specifies the number of logical blocks that the device server shall transfer from the data-out buffer. A VERIFICATION LENGTH field set to zero specifies that no logical blocks shall be verified. This condition shall not be considered as an error. Any other value specifies the number of logical blocks that shall be verified. If the logical block address plus the verification length exceeds the capacity of the medium, the device server shall terminate the command with CHECK CONDITION status with the sense key set to ILLEGAL REQUEST and the additional sense code set to LOGICAL BLOCK ADDRESS OUT OF RANGE. The VERIFICATION LENGTH field is constrained by the MAXIMUM TRANSFER LENGTH field in the Block Limits VPD page (see 6.4.2).

If the BYTCHK bit is set to zero, the device server shall check the protection information read from the medium based on the VRPROTECT field as described in table 54.

Table 54 — VRPROTECT field with BYTCHK set to zero - checking protection information read from the medium (part 1 of 3)

Code	Logical unit formatted with protection information	Field in protection information ^g	Extended INQUIRY Data VPD page bit value ^f	If check fails ^{d e} , additional sense code
000b	Yes	LOGICAL BLOCK GUARD	GRD_CHK = 1	LOGICAL BLOCK GUARD CHECK FAILED
			GRD_CHK = 0	No check performed
		LOGICAL BLOCK APPLICATION TAG	APP_CHK = 1 ^c	LOGICAL BLOCK APPLICATION TAG CHECK FAILED
			APP_CHK = 0	No check performed
		LOGICAL BLOCK REFERENCE TAG	REF_CHK = 1 ^h	LOGICAL BLOCK REFERENCE TAG CHECK FAILED
			REF_CHK = 0	No check performed
	No	No protection information on the medium to check. Only user data is checked.		
001b ^b	Yes	LOGICAL BLOCK GUARD	GRD_CHK = 1	LOGICAL BLOCK GUARD CHECK FAILED
			GRD_CHK = 0	No check performed
		LOGICAL BLOCK APPLICATION TAG	APP_CHK = 1 ^c	LOGICAL BLOCK APPLICATION TAG CHECK FAILED
			APP_CHK = 0	No check performed
		LOGICAL BLOCK REFERENCE TAG	REF_CHK = 1 ^h	LOGICAL BLOCK REFERENCE TAG CHECK FAILED
			REF_CHK = 0	No check performed
	No	Error condition ^a		

Table 54 — VRPROTECT field with BYTCHK set to zero - checking protection information read from the medium (part 2 of 3)

Code	Logical unit formatted with protection information	Field in protection information ^g	Extended INQUIRY Data VPD page bit value ^f	If check fails ^{d e} , additional sense code
010b ^b	Yes	LOGICAL BLOCK GUARD	No check performed	
		LOGICAL BLOCK APPLICATION TAG	APP_CHK = 1 ^c	LOGICAL BLOCK APPLICATION TAG CHECK FAILED
			APP_CHK = 0	No check performed
		LOGICAL BLOCK REFERENCE TAG	REF_CHK = 1 ^h	LOGICAL BLOCK REFERENCE TAG CHECK FAILED
			REF_CHK = 0	No check performed
	No	Error condition ^a		
011b ^b	Yes	LOGICAL BLOCK GUARD	No check performed	
		LOGICAL BLOCK APPLICATION TAG	No check performed	
		LOGICAL BLOCK REFERENCE TAG	No check performed	
	No	Error condition ^a		

Table 54 — VRPROTECT field with BYTCHK set to zero - checking protection information read from the medium (part 3 of 3)

Code	Logical unit formatted with protection information	Field in protection information ^g	Extended INQUIRY Data VPD page bit value ^f	If check fails ^{d e} , additional sense code	
100b ^b	Yes	LOGICAL BLOCK GUARD	GRD_CHK = 1	LOGICAL BLOCK GUARD CHECK FAILED	
			GRD_CHK = 0	No check performed	
		LOGICAL BLOCK APPLICATION TAG	No check performed		
		LOGICAL BLOCK REFERENCE TAG	No check performed		
	No	Error condition ^a			
101b-111b	Reserved				

^a A verify operation to a logical unit that supports protection information (see 4.16) and has not been formatted with protection information shall be terminated with CHECK CONDITION status with the sense key set to ILLEGAL REQUEST and the additional sense code set to INVALID FIELD IN CDB.

^b If the logical unit does not support protection information the requested command should be terminated with CHECK CONDITION status with the sense key set to ILLEGAL REQUEST and the additional sense code set to INVALID FIELD IN CDB.

^c The device server shall check the logical block application tag if it has knowledge of the contents of the LOGICAL BLOCK APPLICATION TAG field. If the VERIFY (32) command (see 5.23) is used and the ATO bit is set to one in the Control mode page (see SPC-4), this knowledge is acquired from the EXPECTED LOGICAL BLOCK APPLICATION TAG field and the LOGICAL BLOCK APPLICATION TAG MASK field in the CDB. Otherwise, this knowledge may be obtained by a method not defined by this standard.

^d If an error is reported, the sense key shall be set to ABORTED COMMAND.

^e If multiple errors occur, the selection of which error to report is not defined by this standard.

^f See the Extended INQUIRY Data VPD page (see SPC-4) for the definitions of the GRD_CHK bit, the APP_CHK bit, and the REF_CHK bits.

^g If the application client or device server detects a LOGICAL BLOCK APPLICATION TAG field set to FFFFh, the checking of all protection information shall be disabled for the associated logical block.

^h If the RTO_EN bit is set to zero in the READ CAPACITY (16) parameter data (see 5.11)(i.e., the command is a VERIFY (10) command, a VERIFY (12) command, or a VERIFY (16) command), the device server shall check the logical block reference tag by comparing it to the lower 4 bytes of the LBA associated with the logical block. If the RTO_EN bit is set to one (i.e., the command is a VERIFY (32) command), the device server shall check the logical block reference tag based on the EXPECTED INITIAL LOGICAL BLOCK REFERENCE TAG field in the CDB (see 4.16.2).

If the BYTCHK bit is set to one, the device server shall check the protection information read from the medium based on the VRPROTECT field as described in table 55.

Table 55 — VRPROTECT field with BYTCHK set to one - checking protection information read from the medium (part 1 of 2)

Code	Logical unit formatted with protection information	Field in protection information ^g	Extended INQUIRY Data VPD page bit value ^f	If check fails ^{d e} , additional sense code
000b	Yes	LOGICAL BLOCK GUARD	GRD_CHK = 1	LOGICAL BLOCK GUARD CHECK FAILED
			GRD_CHK = 0	No check performed
		LOGICAL BLOCK APPLICATION TAG	APP_CHK = 1 ^{c g}	LOGICAL BLOCK APPLICATION TAG CHECK FAILED
			APP_CHK = 0	No check performed
		LOGICAL BLOCK REFERENCE TAG	REF_CHK = 1 ^h	LOGICAL BLOCK REFERENCE TAG CHECK FAILED
			REF_CHK = 0	No check performed
	No	No protection information on the medium available to check		
001b 010b 011b 100b b	Yes	LOGICAL BLOCK GUARD	No check performed	
		LOGICAL BLOCK APPLICATION TAG	No check performed	
		LOGICAL BLOCK REFERENCE TAG	No check performed	
	No	Error condition ^a		

Table 55 — VRPROTECT field with BYTCHK set to one - checking protection information read from the medium (part 2 of 2)

Code	Logical unit formatted with protection information	Field in protection information ^g	Extended INQUIRY Data VPD page bit value ^f	If check fails ^{d e} , additional sense code
101b-111b	Reserved			
<p>^a A verify operation to a logical unit that supports protection information (see 4.16) and has not been formatted with protection information shall be terminated with CHECK CONDITION status with the sense key set to ILLEGAL REQUEST and the additional sense code set to INVALID FIELD IN CDB.</p> <p>^b If the logical unit does not support protection information the requested command should be terminated with CHECK CONDITION status with the sense key set to ILLEGAL REQUEST and the additional sense code set to INVALID FIELD IN CDB.</p> <p>^c The device server shall check the logical block application tag if it has knowledge of the contents of the LOGICAL BLOCK APPLICATION TAG field. If the VERIFY (32) command (see 5.23) is used and the ATO bit is set to one in the Control mode page (see SPC-4), this knowledge is acquired from the EXPECTED LOGICAL BLOCK APPLICATION TAG field and the LOGICAL BLOCK APPLICATION TAG MASK field in the CDB. Otherwise, this knowledge may be obtained by a method not defined by this standard.</p> <p>^d If an error is reported, the sense key shall be set to ABORTED COMMAND.</p> <p>^e If multiple errors occur, the selection of which error to report is not defined by this standard.</p> <p>^f See the Extended INQUIRY Data VPD page (see SPC-4) for the definitions of the GRD_CHK bit, the APP_CHK bit, and the REF_CHK bit.</p> <p>^g If the application client or device server detects a LOGICAL BLOCK APPLICATION TAG field set to FFFFh, the checking of all protection information shall be disabled for the associated logical block.</p> <p>^h If the RTO_EN bit is set to zero in the READ CAPACITY (16) parameter data (see 5.11)(i.e., the command is a VERIFY (10) command, a VERIFY (12) command, or a VERIFY (16) command), the device server shall check the logical block reference tag by comparing it to the lower 4 bytes of the LBA associated with the logical block. If the RTO_EN bit is set to one (i.e., the command is a VERIFY (32) command), the device server shall check the logical block reference tag based on the EXPECTED INITIAL LOGICAL BLOCK REFERENCE TAG field in the CDB (see 4.16.2).</p>				

If the BYTCHK bit is set to one, the device server shall check the protection information transferred from the data-out buffer based on the VRPROTECT field as described in table 56.

Table 56 — VRPROTECT field with BYTCHK set to one - checking protection information from the data-out buffer (part 1 of 3)

Code	Logical unit formatted with protection information	Field in protection information	Device server check	If check fails ^{d e} , additional sense code
000b	Yes	No protection information received from application client to check		
	No	No protection information received from application client to check		

Table 56 — VRPROTECT field with BYTCHK set to one - checking protection information from the data-out buffer (part 2 of 3)

Code	Logical unit formatted with protection information	Field in protection information	Device server check	If check fails ^{d e} , additional sense code
001b ^b	Yes	LOGICAL BLOCK GUARD	Shall	LOGICAL BLOCK GUARD CHECK FAILED
		LOGICAL BLOCK APPLICATION TAG	May ^c	LOGICAL BLOCK APPLICATION TAG CHECK FAILED
		LOGICAL BLOCK REFERENCE TAG	Shall ^f	LOGICAL BLOCK REFERENCE TAG CHECK FAILED
	No	Error condition ^a		
010b ^b	Yes	LOGICAL BLOCK GUARD	Shall not	No check performed
		LOGICAL BLOCK APPLICATION TAG	May ^c	LOGICAL BLOCK APPLICATION TAG CHECK FAILED
		LOGICAL BLOCK REFERENCE TAG	May ^f	LOGICAL BLOCK REFERENCE TAG CHECK FAILED
	No	Error condition ^a		
011b ^b	Yes	LOGICAL BLOCK GUARD	Shall not	No check performed
		LOGICAL BLOCK APPLICATION TAG	Shall not	No check performed
		LOGICAL BLOCK REFERENCE TAG	Shall not	No check performed
	No	Error condition ^a		

Table 56 — VRPROTECT field with BYTCHK set to one - checking protection information from the data-out buffer (part 3 of 3)

Code	Logical unit formatted with protection information	Field in protection information	Device server check	If check fails ^{d e} , additional sense code
100b ^b	Yes	LOGICAL BLOCK GUARD	Shall	LOGICAL BLOCK GUARD CHECK FAILED
		LOGICAL BLOCK APPLICATION TAG	Shall not	No check performed
		LOGICAL BLOCK REFERENCE TAG	Shall not	No check performed
	No	Error condition ^a		
101b-111b	Reserved			

^a A verify operation to a logical unit that supports protection information (see 4.16) and has not been formatted with protection information shall be terminated with CHECK CONDITION status with the sense key set to ILLEGAL REQUEST and the additional sense code set to INVALID FIELD IN CDB.

^b If the logical unit does not support protection information the requested command should be terminated with CHECK CONDITION status with the sense key set to ILLEGAL REQUEST and the additional sense code set to INVALID FIELD IN CDB.

^c The device server may check the logical block application tag if the ATO bit is set to one in the Control mode page (see SPC-4) and if it has knowledge of the contents of the LOGICAL BLOCK APPLICATION TAG field. If the VERIFY (32) command (see 5.23) is used, this knowledge is obtained from the EXPECTED LOGICAL BLOCK APPLICATION TAG field and the LOGICAL BLOCK APPLICATION TAG MASK field in the CDB. Otherwise, this knowledge is obtained by a method not defined by this standard.

^d If an error is reported, the sense key shall be set to ABORTED COMMAND.

^e If multiple errors occur, the selection of which error to report is not defined by this standard.

^f If the RTO_EN bit is set to zero in the READ CAPACITY (16) parameter data (see 5.11)(i.e., the command is a VERIFY (10) command, a VERIFY (12) command, or a VERIFY (16) command), the device server shall check the logical block reference tag by comparing it to the lower 4 bytes of the LBA associated with the logical block. If the RTO_EN bit is set to one (i.e., the command is a VERIFY (32) command), the device server shall check the logical block reference tag based on the EXPECTED INITIAL LOGICAL BLOCK REFERENCE TAG field in the CDB (see 4.16.2).

If the BYTCHK bit is set to one, the device server shall perform a byte-by-byte comparison of protection information transferred from the data-out buffer with protection information read from the medium based on the VRPROTECT field as described in table 57.

Table 57 — VRPROTECT field with BYTCHK set to one - byte-by-byte comparison requirements (part 1 of 2)

Code	Logical unit formatted with protection information	Field	Byte-by-byte Comparison	If compare fails ^{c d} , additional sense code
000b	Yes	No protection information received from application client to compare. Only user data is compared within each logical block.		
	No	No protection information or the medium or received from application client to compare. Only user data is compared within each logical block.		
001b ^b	Yes	LOGICAL BLOCK GUARD	Shall	LOGICAL BLOCK GUARD CHECK FAILED
		LOGICAL BLOCK APPLICATION TAG (ATO = 1) ^e	Shall	LOGICAL BLOCK APPLICATION TAG CHECK FAILED
		LOGICAL BLOCK APPLICATION TAG (ATO = 0) ^f	Shall not	No compare performed
		LOGICAL BLOCK REFERENCE TAG	Shall	LOGICAL BLOCK REFERENCE TAG CHECK FAILED
	No	Error condition ^a		

Table 57 — VRPROTECT field with BYTCHK set to one - byte-by-byte comparison requirements (part 2 of 2)

Code	Logical unit formatted with protection information	Field	Byte-by-byte Comparison	If compare fails ^{c d} , additional sense code
010b ^b	Yes	LOGICAL BLOCK GUARD	Shall not	No compare performed
		LOGICAL BLOCK APPLICATION TAG (ATO = 1) ^e	Shall	LOGICAL BLOCK APPLICATION TAG CHECK FAILED
		LOGICAL BLOCK APPLICATION TAG (ATO = 0) ^f	Shall not	No compare performed
		LOGICAL BLOCK REFERENCE TAG	Shall	LOGICAL BLOCK REFERENCE TAG CHECK FAILED
	No	Error condition ^a		
011b 100b ^b	Yes	LOGICAL BLOCK GUARD	Shall	LOGICAL BLOCK GUARD CHECK FAILED
		LOGICAL BLOCK APPLICATION TAG (ATO = 1) ^e	Shall	LOGICAL BLOCK APPLICATION TAG CHECK FAILED
		LOGICAL BLOCK APPLICATION TAG (ATO = 0) ^f	Shall not	No compare performed
		LOGICAL BLOCK REFERENCE TAG	Shall	LOGICAL BLOCK REFERENCE TAG CHECK FAILED
	No	Error condition ^a		
101b - 111b	Reserved			
^a A verify operation to a logical unit that supports protection information (see 4.16) and has not been formatted with protection information shall be terminated with CHECK CONDITION status with the sense key set to ILLEGAL REQUEST and the additional sense code set to INVALID FIELD IN CDB. ^b If the logical unit does not support protection information the requested command should be terminated with CHECK CONDITION status with the sense key set to ILLEGAL REQUEST and the additional sense code set to INVALID FIELD IN CDB. ^c If an error is reported, the sense key shall be set to MISCOMPARE. ^d If multiple errors occur, the selection of which error to report is not defined by this standard. ^e If the ATO bit is set to one in the Control mode page (see SPC-4), the logical block application tag shall not be modified by a device server. ^f If the ATO bit is set to zero in the Control mode page (see SPC-4), the logical block application tag may be modified by a device server.				

5.21 VERIFY (12) command

The VERIFY (12) command (see table 58) requests that the device server verify the specified logical block(s) on the medium. Each logical block includes user data and may include protection information, based on the VRPROTECT field and the medium format.

If the RTO_EN bit is set to one in the READ CAPACITY (16) parameter data (see 5.11), the device server shall terminate this command with CHECK CONDITION status with the sense key set to ILLEGAL REQUEST and the additional sense code set to INVALID COMMAND OPERATION CODE.

Table 58 — VERIFY (12) command

Byte\Bit	7	6	5	4	3	2	1	0
0	OPERATION CODE (AFh)							
1	VRPROTECT			DPO	Reserved		BYTCHK	Obsolete
2	(MSB) _____ LOGICAL BLOCK ADDRESS _____ (LSB)							
5	(MSB) _____ VERIFICATION LENGTH _____ (LSB)							
6	(MSB) _____ VERIFICATION LENGTH _____ (LSB)							
9	(MSB) _____ VERIFICATION LENGTH _____ (LSB)							
10	Restricted for MMC-4	Reserved		GROUP NUMBER				
11	CONTROL							

See the VERIFY (10) command (see 5.20) for the definitions of the fields in this command.

5.22 VERIFY (16) command

The VERIFY (16) command (see table 59) requests that the device server verify the specified logical block(s) on the medium. Each logical block includes user data and may include protection information, based on the VRPROTECT field and the medium format.

If the RTO_EN bit is set to one in the READ CAPACITY (16) parameter data (see 5.11), the device server shall terminate this command with CHECK CONDITION status with the sense key set to ILLEGAL REQUEST and the additional sense code set to INVALID COMMAND OPERATION CODE.

Table 59 — VERIFY (16) command

Byte\Bit	7	6	5	4	3	2	1	0
0	OPERATION CODE (8Fh)							
1	VRPROTECT			DPO	Reserved		BYTCHK	Reserved
2	(MSB) _____ LOGICAL BLOCK ADDRESS _____ (LSB)							
9	(MSB) _____ VERIFICATION LENGTH _____ (LSB)							
10	(MSB) _____ VERIFICATION LENGTH _____ (LSB)							
13	(MSB) _____ VERIFICATION LENGTH _____ (LSB)							
14	Restricted for MMC-4	Reserved		GROUP NUMBER				
15	CONTROL							

See the VERIFY (10) command (see 5.20) for the definitions of the fields in this command.

5.23 VERIFY (32) command

The VERIFY (32) command (see table 60) requests that the device server verify the specified logical block(s) on the medium. Each logical block includes user data and may include protection information, based on the VRPROTECT field and the medium format.

If the RTO_EN bit is set to zero in the READ CAPACITY (16) parameter data (see 5.11), the device server shall terminate this command with CHECK CONDITION status with the sense key set to ILLEGAL REQUEST and the additional sense code set to INVALID COMMAND OPERATION CODE.

Table 60 — VERIFY (32) command

Byte/Bit	7	6	5	4	3	2	1	0
0	OPERATION CODE (7Fh)							
1	CONTROL							
2	Reserved							
5	Reserved							
6	Reserved			GROUP NUMBER				
7	ADDITIONAL CDB LENGTH (18h)							
8	(MSB)	SERVICE ACTION (000Ah)						(LSB)
9	Reserved							
10	VRPROTECT			DPO	Reserved		BYTCHK	Reserved
11	Reserved							
12	(MSB)	LOGICAL BLOCK ADDRESS						(LSB)
19	Reserved							
20	(MSB)	EXPECTED INITIAL LOGICAL BLOCK REFERENCE TAG						(LSB)
23	Reserved							
24	(MSB)	EXPECTED LOGICAL BLOCK APPLICATION TAG						(LSB)
25	Reserved							
26	(MSB)	LOGICAL BLOCK APPLICATION TAG MASK						(LSB)
27	Reserved							
28	(MSB)	VERIFICATION LENGTH						(LSB)
31	Reserved							

See the VERIFY (10) command (see 5.20) for the definitions of the GROUP NUMBER field, VRPROTECT field, DPO bit, BYTCHK bit, LOGICAL BLOCK ADDRESS field, and VERIFICATION LENGTH field.

When checking of the LOGICAL BLOCK REFERENCE TAG field is enabled (see table 54, table 55, table 56, and table 57 in 5.20), the EXPECTED INITIAL LOGICAL BLOCK REFERENCE TAG field contains the value of the LOGICAL BLOCK REFERENCE TAG field expected in the protection information of the first logical block accessed by the command instead of a value based on the LBA (see 4.16.2).

If the ATO bit is set to one in the Control mode page (see SPC-4) and checking of the LOGICAL BLOCK APPLICATION TAG field is enabled (see table 54, table 55, table 56, and table 57 in 5.20), the LOGICAL BLOCK APPLICATION TAG MASK field contains a value that is a bit mask for enabling the checking of the LOGICAL BLOCK APPLICATION TAG field in the protection information for each logical block accessed by the command. A LOGICAL BLOCK APPLICATION TAG MASK bit set to one enables the checking of the corresponding bit of the EXPECTED LOGICAL BLOCK APPLICATION TAG field with the corresponding bit of the LOGICAL BLOCK APPLICATION TAG field in the protection information.

If the ATO bit is set to one in the Control mode page (see SPC-4) and checking of the LOGICAL BLOCK APPLICATION TAG field is disabled (see table 54, table 55, table 56, and table 57 in 5.20), or if the ATO bit is set to zero, the LOGICAL BLOCK APPLICATION TAG MASK field and the EXPECTED LOGICAL BLOCK APPLICATION TAG field shall be ignored.

5.24 WRITE (6) command

The WRITE (6) command (see table 61) requests that the device server transfer the specified logical block(s) from the data-out buffer and write them. Each logical block transferred includes user data but does not include protection information. Each logical block written includes user data and, if the medium is formatted with protection information enabled, protection information.

Table 61 — WRITE (6) command

Byte\Bit	7	6	5	4	3	2	1	0
0	OPERATION CODE (0Ah)							
1	Reserved			(MSB)				
2	LOGICAL BLOCK ADDRESS							
3	(LSB)							
4	TRANSFER LENGTH							
5	CONTROL							

The cache control bits are not provided for this command. Direct-access block devices with cache may have values for the cache control bits that may affect the WRITE (6) command, however no default value is defined by this standard. If explicit control is required, the WRITE (10) command should be used.

See the PRE-FETCH (10) command (see 5.3) for the definition of the LOGICAL BLOCK ADDRESS field.

The TRANSFER LENGTH field specifies the number of contiguous logical blocks of data that shall be transferred from the data-out buffer and written, starting with the logical block specified by the LOGICAL BLOCK ADDRESS field. A TRANSFER LENGTH field set to zero specifies that 256 logical blocks shall be written. Any other value specifies the number of logical blocks that shall be written. If the logical block address plus the transfer length exceeds the capacity of the medium, the device server shall terminate the command with CHECK CONDITION status with the sense key set to ILLEGAL REQUEST and the additional sense code set to LOGICAL BLOCK ADDRESS OUT OF RANGE. The TRANSFER LENGTH field is constrained by the MAXIMUM TRANSFER LENGTH field in the Block Limits VPD page (see 6.4.2).

NOTE 20 - For the WRITE (10) command, WRITE (12) command, WRITE (16) command, and WRITE (32) command, a TRANSFER LENGTH field set to zero specifies that no logical blocks are transferred.

If a WRITE (6) command is received after protection information is enabled the device server shall set the protection information (see 4.16) as follows as it writes each logical block to the medium:

- a) the LOGICAL BLOCK GUARD field set to a properly generated CRC (see 4.16.3);
- b) the LOGICAL BLOCK REFERENCE TAG field set to:
 - A) the least significant four bytes of the LBA, if the RTO_EN bit is set to zero in the READ CAPACITY (16) parameter data (see 5.11); or
 - B) FFFFFFFFh, if the RTO_EN bit is set to one;
 and
- c) the LOGICAL BLOCK APPLICATION TAG field set to:
 - A) FFFFh, if the ATO bit is set to one in the Control mode page (see SPC-4); or
 - B) any value, if the ATO bit is set to zero in the Control mode page (see SPC-4).

5.25 WRITE (10) command

The WRITE (10) command (see table 62) requests that the device server transfer the specified logical block(s) from the data-out buffer and write them. Each logical block transferred includes user data and may include protection information, based on the WRPROTECT field and the medium format. Each logical block

written includes user data and, if the medium is formatted with protection information enabled, protection information.

Table 62 — WRITE (10) command

Byte/Bit	7	6	5	4	3	2	1	0
0	OPERATION CODE (2Ah)							
1	WRPROTECT			DPO	FUA	Reserved	FUA_NV	Obsolete
2	(MSB) _____ LOGICAL BLOCK ADDRESS _____ (LSB)							
5								
6	Reserved			GROUP NUMBER				
7	(MSB) _____ TRANSFER LENGTH _____ (LSB)							
8								
9	CONTROL							

See the READ (10) command (see 5.6) for the definition of the DPO bit. See the PRE-FETCH (10) command (see 5.3) for the definition of the LOGICAL BLOCK ADDRESS field. See the PRE-FETCH (10) command (see 5.3) and 4.17 for the definition of the GROUP NUMBER field.

The device server shall check the protection information transferred from the data-out buffer based on the WRPROTECT field as described in table 63.

Table 63 — WRPROTECT field (part 1 of 3)

Code	Logical unit formatted with protection information	Field in protection information	Device server check	If check fails ^{d i} , additional sense code
000b	Yes ^{f g h}	No protection information received from application client to check		
	No	No protection information received from application client to check		
001b ^{b j}	Yes ^e	LOGICAL BLOCK GUARD	Shall	LOGICAL BLOCK GUARD CHECK FAILED
		LOGICAL BLOCK APPLICATION TAG	May ^c	LOGICAL BLOCK APPLICATION TAG CHECK FAILED
		LOGICAL BLOCK REFERENCE TAG	Shall ^k	LOGICAL BLOCK REFERENCE TAG CHECK FAILED
	No ^a	No protection information available to check		
010b ^{b j}	Yes ^e	LOGICAL BLOCK GUARD	Shall not	No check performed
		LOGICAL BLOCK APPLICATION TAG	May ^c	LOGICAL BLOCK APPLICATION TAG CHECK FAILED
		LOGICAL BLOCK REFERENCE TAG	May ^k	LOGICAL BLOCK REFERENCE TAG CHECK FAILED
	No ^a	No protection information available to check		

Table 63 — WRPROTECT field (part 2 of 3)

Code	Logical unit formatted with protection information	Field in protection information	Device server check	If check fails ^{d i} , additional sense code
011b ^{b j}	Yes ^e	LOGICAL BLOCK GUARD	Shall not	No check performed
		LOGICAL BLOCK APPLICATION TAG	Shall not	No check performed
		LOGICAL BLOCK REFERENCE TAG	Shall not	No check performed
	No ^a	No protection information available to check		
100b ^{b j}	Yes ^e	LOGICAL BLOCK GUARD	Shall	LOGICAL BLOCK GUARD CHECK FAILED
		LOGICAL BLOCK APPLICATION TAG	Shall not	No check performed
		LOGICAL BLOCK REFERENCE TAG	Shall not	No check performed
	No ^a	No protection information available to check		

Table 63 — WRPROTECT field (part 3 of 3)

Code	Logical unit formatted with protection information	Field in protection information	Device server check	If check fails ^{d i} , additional sense code
101b-111b	Reserved			
<p>^a A write operation to a logical unit that supports protection information (see 4.16) and has not been formatted with protection information shall be terminated with CHECK CONDITION status with the sense key set to ILLEGAL REQUEST and the additional sense code set to INVALID FIELD IN CDB.</p> <p>^b If the logical unit does not support protection information the requested command should be terminated with CHECK CONDITION status with the sense key set to ILLEGAL REQUEST and the additional sense code set to INVALID FIELD IN CDB.</p> <p>^c The device server may check the logical block application tag if the ATO bit is set to one in the Control mode page (see SPC-4) and if it has knowledge of the contents of the LOGICAL BLOCK APPLICATION TAG field. If the WRITE (32) command (see 5.28) is used, this knowledge is obtained from the EXPECTED LOGICAL BLOCK APPLICATION TAG field and the LOGICAL BLOCK APPLICATION TAG MASK field in the CDB. Otherwise, this knowledge is obtained by a method not defined by this standard.</p> <p>^d If an error is reported, the sense key shall be set to ABORTED COMMAND.</p> <p>^e Device server shall preserve the contents of protection information (e.g., write to medium, store in non-volatile memory).</p> <p>^f The device server shall write a properly generated CRC (see 4.16.3.2) into each LOGICAL BLOCK GUARD field.</p> <p>^g If the RTO_EN bit is set to zero in the READ CAPACITY (16) parameter data (see 5.11), the device server shall write the least significant four bytes of each LBA into the LOGICAL BLOCK REFERENCE TAG field of each of the written logical blocks. If the RTO_EN bit is set to one, the device server shall write a value of FFFFFFFFh into the LOGICAL BLOCK REFERENCE TAG field of each of the written logical blocks.</p> <p>^h If the ATO bit is set to one in the Control mode page (see SPC-4), the device server shall write FFFFh into each LOGICAL BLOCK APPLICATION TAG field. If the ATO bit is set to zero, the device server may write any value into each LOGICAL BLOCK APPLICATION TAG field.</p> <p>ⁱ If multiple errors occur, the selection of which error to report is not defined by this standard.</p> <p>^j If the RTO_EN bit is set to zero in the READ CAPACITY (16) parameter data (see 5.11), the device server may process the command. If the RTO_EN bit is set to one, WRITE (10) commands, WRITE (12) commands, and WRITE (16) commands with the WRPROTECT field set to 000b may be processed by the device server. If the RTO_EN bit is set to one, the device server shall terminate WRITE (10) commands, WRITE (12) commands, and WRITE (16) commands with the WRPROTECT field not set to 000b with CHECK CONDITION status with the sense key set to ILLEGAL REQUEST and the additional sense code set to INVALID COMMAND OPERATION CODE.</p> <p>^k If the RTO_EN bit is set to zero in the READ CAPACITY (16) parameter data (see 5.11), the device server checks the logical block reference tag by comparing it to the lower 4 bytes of the LBA associated with the logical block. If the RTO_EN bit is set to one (i.e., the command is a WRITE (32) command), the device server checks the logical block reference tag based on the EXPECTED INITIAL LOGICAL BLOCK REFERENCE TAG field in the CDB (see 4.16.2).</p>				

The force unit access (FUA) and force unit access non-volatile cache (FUA_NV) bits are defined in table 64.

Table 64 — Force unit access for write operations

FUA	FUA_NV	Description
0	0	The device server shall write the logical blocks to volatile cache, non-volatile cache, and/or the medium.
0	1	If the NV_SUP bit is set to one in the Extended INQUIRY Data VPD page (see SPC-4), the device server shall write the logical blocks to non-volatile cache and/or the medium. If the NV_SUP bit is set to zero in the Extended INQUIRY Data VPD page (see SPC-4), the device server shall write the logical blocks to volatile cache, non-volatile cache, and/or the medium.
1	0 or 1	The device server shall write the logical blocks to the medium, and shall not return GOOD status until the logical blocks have actually been written on the medium.

If logical blocks are transferred directly to a cache, the device server may return GOOD status prior to writing the logical blocks to the medium. Any error that occurs after the GOOD status is returned is a deferred error, and information regarding the error is not reported until a subsequent command.

The TRANSFER LENGTH field specifies the number of contiguous logical blocks of data that shall be transferred from the data-out buffer and written, starting with the logical block specified by the LOGICAL BLOCK ADDRESS field. A TRANSFER LENGTH field set to zero specifies that no logical blocks shall be written. This condition shall not be considered an error. Any other value specifies the number of logical blocks that shall be written. If the logical block address plus the transfer length exceeds the capacity of the medium, the device server shall terminate the command with CHECK CONDITION status with the sense key set to ILLEGAL REQUEST and the additional sense code set to LOGICAL BLOCK ADDRESS OUT OF RANGE. The TRANSFER LENGTH field is constrained by the MAXIMUM TRANSFER LENGTH field in the Block Limits VPD page (see 6.4.2).

NOTE 21 - For the WRITE (6) command, a TRANSFER LENGTH field set to zero specifies that 256 logical blocks are transferred.

5.26 WRITE (12) command

The WRITE (12) command (see table 65) requests that the device server transfer the specified logical block(s) from the data-out buffer and write them. Each logical block transferred includes user data and may include protection information, based on the WRPROTECT field and the medium format. Each logical block written includes user data and, if the medium is formatted with protection information enabled, protection information.

Table 65 — WRITE (12) command

Byte\Bit	7	6	5	4	3	2	1	0
0	OPERATION CODE (AAh)							
1	WRPROTECT			DPO	FUA	Reserved	FUA_NV	Obsolete
2	(MSB) _____ LOGICAL BLOCK ADDRESS _____ (LSB)							
5	(MSB) _____ TRANSFER LENGTH _____ (LSB)							
6	(MSB) _____ TRANSFER LENGTH _____ (LSB)							
9	(MSB) _____ TRANSFER LENGTH _____ (LSB)							
10	Restricted for MMC-4	Reserved		GROUP NUMBER				
11	CONTROL							

See the WRITE (10) command (see 5.25) for the definitions of the fields in this command.

5.27 WRITE (16) command

The WRITE (16) command (see table 66) requests that the device server transfer the specified logical block(s) from the data-out buffer and write them. Each logical block transferred includes user data and may include protection information, based on the WRPROTECT field and the medium format. Each logical block written includes user data and, if the medium is formatted with protection information enabled, protection information.

Table 66 — WRITE (16) command

Byte\Bit	7	6	5	4	3	2	1	0
0	OPERATION CODE (8Ah)							
1	WRPROTECT			DPO	FUA	Reserved	FUA_NV	Reserved
2	(MSB) _____ LOGICAL BLOCK ADDRESS _____ (LSB)							
9								
10	(MSB) _____ TRANSFER LENGTH _____ (LSB)							
13								
14	Restricted for MMC-4	Reserved		GROUP NUMBER				
15	CONTROL							

See the WRITE (10) command (see 5.25) for the definitions of the fields in this command.

5.28 WRITE (32) command

The WRITE (32) command (see table 67) requests that the device server transfer the specified logical block(s) from the data-out buffer and write them. Each logical block transferred includes user data and may include protection information, based on the WRPROTECT field and the medium format. Each logical block written includes user data and, if the medium is formatted with protection information enabled, protection information.

If the RTO_EN bit is set to zero in the READ CAPACITY (16) parameter data (see 5.11), the device server shall terminate the WRITE (32) command with CHECK CONDITION status with the sense key set to ILLEGAL

REQUEST and the additional sense code set to INVALID COMMAND OPERATION CODE. If the RTO_EN bit is set to one, the device server may process the command.

Table 67 — WRITE (32) command

Byte\Bit	7	6	5	4	3	2	1	0
0	OPERATION CODE (7Fh)							
1	CONTROL							
2	Reserved							
5	Reserved							
6	Reserved			GROUP NUMBER				
7	ADDITIONAL CDB LENGTH (18h)							
8	(MSB)	SERVICE ACTION (000Bh)						(LSB)
9								
10	WRPROTECT			DPO	FUA	Reserved	FUA_NV	Reserved
11	Reserved							
12	(MSB)	LOGICAL BLOCK ADDRESS						(LSB)
19								
20	(MSB)	EXPECTED INITIAL LOGICAL BLOCK REFERENCE TAG						(LSB)
23								
24	(MSB)	EXPECTED LOGICAL BLOCK APPLICATION TAG						(LSB)
25								
26	(MSB)	LOGICAL BLOCK APPLICATION TAG MASK						(LSB)
27								
28	(MSB)	TRANSFER LENGTH						(LSB)
31								

See the WRITE (10) command (see 5.25) for the definitions of the GROUP NUMBER field, the WRPROTECT field, the DPO bit, the FUA bit, the FUA_NV bit, the LOGICAL BLOCK ADDRESS field, and the TRANSFER LENGTH field.

When checking of the LOGICAL BLOCK REFERENCE TAG field is enabled (see table 63 in 5.25), the EXPECTED INITIAL LOGICAL BLOCK REFERENCE TAG field contains the value of the LOGICAL BLOCK REFERENCE TAG field expected in the protection information of the first logical block accessed by the command instead of a value based on the LBA (see 4.16.2).

If the ATO bit is set to one in the Control mode page (see SPC-4) and checking of the LOGICAL BLOCK APPLICATION TAG field is enabled (see table 63 in 5.25), the LOGICAL BLOCK APPLICATION TAG MASK field contains a value that is a bit mask for enabling the checking of the LOGICAL BLOCK APPLICATION TAG field in the protection information for each logical block accessed by the command. A LOGICAL BLOCK APPLICATION TAG MASK bit set to one enables the checking of the corresponding bit of the EXPECTED LOGICAL BLOCK APPLICATION TAG field with the corresponding bit of the LOGICAL BLOCK APPLICATION TAG field in the protection information.

If the ATO bit is set to one in the Control mode page (see SPC-4) and checking of the LOGICAL BLOCK APPLICATION TAG field is disabled (see table 63 in 5.25), or if the ATO bit is set to zero, the LOGICAL BLOCK APPLICATION TAG MASK field and the EXPECTED LOGICAL BLOCK APPLICATION TAG field shall be ignored.

5.29 WRITE AND VERIFY (10) command

The WRITE AND VERIFY (10) command (see table 68) requests that the device server transfer the specified logical block(s) from the data-out buffer, write them to the medium, and then verify that they are correctly written. Each logical block includes user data and may include protection information, based on the WRPROTECT field and the medium format. The logical blocks are only transferred once from the data-out buffer to the device server.

If the RTO_EN bit is set to one in the READ CAPACITY (16) parameter data (see 5.11), the device server shall terminate this command with CHECK CONDITION status with the sense key set to ILLEGAL REQUEST and the additional sense code set to INVALID COMMAND OPERATION CODE.

Table 68 — WRITE AND VERIFY (10) command

Byte\Bit	7	6	5	4	3	2	1	0
0	OPERATION CODE (2Eh)							
1	WRPROTECT			DPO	Reserved		BYTCHK	Obsolete
2	(MSB) LOGICAL BLOCK ADDRESS (LSB)							
5								
6	Reserved			GROUP NUMBER				
7	(MSB) TRANSFER LENGTH (LSB)							
8								
9	CONTROL							

See the PRE-FETCH (10) command (see 5.3) for the definition of the LOGICAL BLOCK ADDRESS field. See the PRE-FETCH (10) command (see 5.3) and 4.17 for the definition of the GROUP NUMBER field. See the WRITE (10) command (see 5.25) for the definitions of the TRANSFER LENGTH field and the WRPROTECT field. See the READ (10) command (see 5.6) for the definition of the DPO bit.

If the Verify Error Recovery mode page (see 6.3.6) is also implemented, then the current settings in that mode page along with the AWRE bit in the Read-Write Error Recovery mode page (see 6.3.5) specify the verification error criteria. If these mode pages are not implemented, then the verification criteria is vendor-specific.

A byte check (BYTCHK) bit set to zero specifies that, after writing, the device server perform a medium verification with no data comparison. A BYTCHK bit set to one specifies that, after writing, the device server perform a byte-by-byte comparison of data written on the medium with the data just written. If the comparison is unsuccessful for any reason, the device server shall terminate the command with CHECK CONDITION status with the sense key set to MISCOMPARE and the additional sense code set to the appropriate value for the condition.

5.30 WRITE AND VERIFY (12) command

The WRITE AND VERIFY (12) command (see table 69) requests that the device server transfer the specified logical block(s) from the data-out buffer, write them to the medium, and then verify that they are correctly written. Each logical block includes user data and may include protection information, based on the WRPROTECT field and the medium format. The logical blocks are only transferred once from the data-out buffer to the device server.

If the RTO_EN bit is set to one in the READ CAPACITY (16) parameter data (see 5.11), the device server shall terminate this command with CHECK CONDITION status with the sense key set to ILLEGAL REQUEST and the additional sense code set to INVALID COMMAND OPERATION CODE.

Table 69 — WRITE AND VERIFY (12) command

Byte\Bit	7	6	5	4	3	2	1	0
0	OPERATION CODE (AEh)							
1	WRPROTECT		DPO		Reserved		BYTCHK	Obsolete
2	(MSB) _____ LOGICAL BLOCK ADDRESS _____ (LSB)							
5	(MSB) _____ TRANSFER LENGTH _____ (LSB)							
6	(MSB) _____ TRANSFER LENGTH _____ (LSB)							
9	(MSB) _____ TRANSFER LENGTH _____ (LSB)							
10	Restricted for MMC-4	Reserved		GROUP NUMBER				
11	CONTROL							

See the WRITE AND VERIFY (10) command (see 5.29) for the definitions of the fields in this command.

5.31 WRITE AND VERIFY (16) command

The WRITE AND VERIFY (16) command (see table 70) requests that the device server transfer the specified logical block(s) from the data-out buffer, write them to the medium, and then verify that they are correctly written. Each logical block includes user data and may include protection information, based on the WRPROTECT field and the medium format. The logical blocks are only transferred once from the data-out buffer to the device server.

If the RTO_EN bit is set to one in the READ CAPACITY (16) parameter data (see 5.11), the device server shall terminate this command with CHECK CONDITION status with the sense key set to ILLEGAL REQUEST and the additional sense code set to INVALID COMMAND OPERATION CODE

Table 70 — WRITE AND VERIFY (16) command

Byte\Bit	7	6	5	4	3	2	1	0
0	OPERATION CODE (8Eh)							
1	WRPROTECT		DPO		Reserved		BYTCHK	Reserved
2	(MSB) _____ LOGICAL BLOCK ADDRESS _____ (LSB)							
9	(MSB) _____ TRANSFER LENGTH _____ (LSB)							
10	(MSB) _____ TRANSFER LENGTH _____ (LSB)							
13	(MSB) _____ TRANSFER LENGTH _____ (LSB)							
14	Restricted for MMC-4	Reserved		GROUP NUMBER				
15	CONTROL							

See the WRITE AND VERIFY (10) command (see 5.29) for the definitions of the fields in this command.

5.32 WRITE AND VERIFY (32) command

The WRITE AND VERIFY (32) command (see table 71) requests that the device server transfer the specified logical block(s) from the data-out buffer, write them to the medium, and then verify that they are correctly

written. Each logical block includes user data and may include protection information, based on the WRPROTECT field and the medium format. The logical blocks are only transferred once from the data-out buffer to the device server.

If the RTO_EN bit is set to zero in the READ CAPACITY (16) parameter data (see 5.11), the device server shall terminate the command with CHECK CONDITION status with the sense key set to ILLEGAL REQUEST and the additional sense code set to INVALID COMMAND OPERATION CODE. If the RTO_EN bit is set to one, the device server may process the command.

Table 71 — WRITE AND VERIFY (32) command

Byte\Bit	7	6	5	4	3	2	1	0
0	OPERATION CODE (7Fh)							
1	CONTROL							
2	Reserved							
5	Reserved							
6	Reserved			GROUP NUMBER				
7	ADDITIONAL CDB LENGTH (18h)							
8	(MSB)							
9	SERVICE ACTION (000Ch)							
10	WRPROTECT			DPO	Reserved		BYTCHK	Reserved
11	Reserved							
12	(MSB)							
19	LOGICAL BLOCK ADDRESS							
20	(MSB)							
23	EXPECTED INITIAL LOGICAL BLOCK REFERENCE TAG							
24	(MSB)							
25	EXPECTED LOGICAL BLOCK APPLICATION TAG							
26	(MSB)							
27	LOGICAL BLOCK APPLICATION TAG MASK							
28	(MSB)							
31	TRANSFER LENGTH							
								(LSB)

See the WRITE AND VERIFY (10) command (see 5.29) for the definitions of the GROUP NUMBER field, the WRPROTECT field, the DPO bit, the BYTCHK bit, the LOGICAL BLOCK ADDRESS field, and the TRANSFER LENGTH field.

When checking of the LOGICAL BLOCK REFERENCE TAG field is enabled (see table 63 in 5.25), the EXPECTED INITIAL LOGICAL BLOCK REFERENCE TAG field contains the value of the LOGICAL BLOCK REFERENCE TAG field expected in the protection information of the first logical block accessed by the command instead of a value based on the LBA (see 4.16.2).

If the ATO bit is set to one in the Control mode page (see SPC-4) and checking of the LOGICAL BLOCK APPLICATION TAG field is enabled (see table 63 in 5.25), the LOGICAL BLOCK APPLICATION TAG MASK field contains a value that is a bit mask for enabling the checking of the LOGICAL BLOCK APPLICATION TAG field in the protection information for each logical block accessed by the command. A LOGICAL BLOCK APPLICATION TAG MASK bit set to one enables the checking of the corresponding bit of the EXPECTED LOGICAL BLOCK APPLICATION TAG field with the corresponding bit of the LOGICAL BLOCK APPLICATION TAG field in the protection information.

If the ATO bit is set to one in the Control mode page (see SPC-4) and checking of the LOGICAL BLOCK APPLICATION TAG field is disabled (see table 63 in 5.25), or if the ATO bit is set to zero, the LOGICAL BLOCK APPLICATION TAG MASK field and the EXPECTED LOGICAL BLOCK APPLICATION TAG field shall be ignored.

5.33 WRITE LONG (10) command

The WRITE LONG (10) command (see table 72) requests that the device server transfer data for a single logical block from the data-out buffer and write it to the medium. The data written shall be the same length and shall be in the same order as the data returned by the READ LONG (10) command (see 5.14). The device server shall write the logical block to the medium, and shall not return GOOD status until the logical block has actually been written on the medium.

Table 72 — WRITE LONG (10) command

Byte/Bit	7	6	5	4	3	2	1	0	
0	OPERATION CODE (3Fh)								
1	Reserved							Obsolete	
2	(MSB)	LOGICAL BLOCK ADDRESS							
5							(LSB)		
6	Reserved								
7	(MSB)	BYTE TRANSFER LENGTH							
8							(LSB)		
9	CONTROL								

See the PRE-FETCH (10) command (see 5.3) for the definition of the LOGICAL BLOCK ADDRESS field.

The BYTE TRANSFER LENGTH field specifies the number of bytes of data that the device server shall transfer from the data-out buffer and write to the specified logical block. If the BYTE TRANSFER LENGTH field is not set to zero and does not match the data length that the device server returns for a READ LONG command, then the device server shall terminate the command with CHECK CONDITION status with the sense key set to ILLEGAL REQUEST and the additional sense code set to INVALID FIELD IN CDB. In the sense data (see 4.13 and SPC-4), the ILI and VALID bits shall be set to one and the INFORMATION field shall be set to the difference (i.e., residue) of the requested length minus the actual length in bytes. Negative values shall be indicated by two's complement notation. A BYTE TRANSFER LENGTH field set to zero specifies that no bytes shall be written. This condition shall not be considered an error.

5.34 WRITE LONG (16) command

The WRITE LONG (16) command (see table 73) requests that the device server transfer data for a single logical block from the data-out buffer and write it to the medium. The data written shall be the same length and shall be in the same order as the data returned by the READ LONG (16) command (see 5.15). The device server shall write the logical block to the medium, and shall not return GOOD status until the logical block has

actually been written on the medium. This command is implemented as a service action of the SERVICE ACTION OUT operation code (see A.2).

Table 73 — WRITE LONG (16) command

Byte\Bit	7	6	5	4	3	2	1	0
0	OPERATION CODE (9Fh)							
1	Reserved			SERVICE ACTION (11h)				
2	(MSB) _____ LOGICAL BLOCK ADDRESS _____ (LSB)							
9								
10	Reserved							
11								
12	(MSB) _____ BYTE TRANSFER LENGTH _____ (LSB)							
13								
14	Reserved							
15	CONTROL							

See the WRITE LONG (10) command (see 5.33) for the definitions of the fields in this command.

5.35 WRITE SAME (10) command

The WRITE SAME (10) command (see table 74) requests that the device server transfer a single logical block from the data-out buffer and write the contents of that logical block, with modifications based on the LBDATA bit and the PBDATA bit, to the specified range of logical block addresses. Each logical block includes user data and may include protection information, based on the WRPROTECT field and the medium format.

If the RTO_EN bit is set to one in the READ CAPACITY (16) parameter data (see 5.11), the device server shall terminate this command with CHECK CONDITION status with the sense key set to ILLEGAL REQUEST and the additional sense code set to INVALID COMMAND OPERATION CODE.

NOTE 22 - This command may be useful if large areas of the medium need to be written, prepared for certification, or otherwise initialized without having to transfer all the data.

Table 74 — WRITE SAME (10) command

Byte\Bit	7	6	5	4	3	2	1	0
0	OPERATION CODE (41h)							
1	WRPROTECT			Reserved		PBDATA	LBDATA	Obsolete
2	(MSB) _____ LOGICAL BLOCK ADDRESS _____ (LSB)							
5								
6	Reserved			GROUP NUMBER				
7	(MSB) _____ NUMBER OF BLOCKS _____ (LSB)							
8								
9	CONTROL							

See the WRITE (10) command (see 5.25) for the definitions of the WRPROTECT field. See the PRE-FETCH (10) command (see 5.3) for the definition of the LOGICAL BLOCK ADDRESS field. See the PRE-FETCH (10) command (see 5.3) and 4.17 for the definition of the GROUP NUMBER field.

Table 75 describes the LBADATA bit and the PBDATA bit.

Table 75 — LBADATA bit and PBDATA bit

LBADATA	PBDATA	Description
0	0	<p>The device server shall write the single block of user data received from the data-out buffer to each logical block without modification.</p> <p>If the medium is formatted with protection information:</p> <ul style="list-style-type: none"> a) the value in the LOGICAL BLOCK REFERENCE TAG field received in the single block of data from the data-out buffer shall be placed into the LOGICAL BLOCK REFERENCE TAG field of the first logical block written to the medium. Into each of the subsequent logical blocks, the device server shall place into the LOGICAL BLOCK REFERENCE TAG field the value of the previous logical block's LOGICAL BLOCK REFERENCE TAG field plus one; b) If the ATO bit is set to one in the Control mode page (see SPC-4), the logical block application tag received in the single block of data shall be placed in the LOGICAL BLOCK APPLICATION TAG field of each logical block. If the ATO bit is set to zero, the device server may write any value into the LOGICAL BLOCK APPLICATION TAG field of each logical block; and c) The value in the DATA BLOCK GUARD field received in the single block of data from the data-out buffer shall be placed in the DATA BLOCK GUARD field of each logical block.
0	1 ^a	The device server shall replace the first eight bytes of the block received from the data-out buffer to each physical sector with the physical address of the sector being written using the physical sector format (see 5.2.2.4.5).
1 ^a	0	The device server shall replace the first four bytes of the block received from the data-out buffer with the least significant four bytes of the LBA of the block being written, ending with the least significant byte (e.g., if the LBA is 77665544_33221100h, 33221100h is written with 33h written first and 00h written last).
1	1	The device server shall terminate the command with CHECK CONDITION status with the sense key set to ILLEGAL REQUEST and the additional sense code set to INVALID FIELD IN CDB.
<p>^a If the medium is formatted with protection information then the protection information shall be written to a default value of FFFFFFFF_FFFFFFFFh in each of the written logical blocks.</p>		

The NUMBER OF BLOCKS field specifies the number of contiguous logical blocks to be written, starting with the logical block specified by the LOGICAL BLOCK ADDRESS field. A NUMBER OF BLOCKS field set to zero specifies that the device server write all the logical blocks starting with the one specified in the LOGICAL BLOCK ADDRESS field to the last logical block on the medium. If the logical block address plus the number of blocks exceeds the capacity of the medium, the device server shall terminate the command with CHECK CONDITION status with the sense key set to ILLEGAL REQUEST and the additional sense code set to LOGICAL BLOCK ADDRESS OUT OF RANGE.

5.36 WRITE SAME (16) command

The WRITE SAME (16) command (see table 76) requests that the device server transfer a single logical block from the data-out buffer and write the contents of that logical block, with modifications based on the LBADATA bit and the PBDATA bit, to the specified range of logical block addresses. Each logical block includes user data and may include protection information, based on the WRPROTECT field and the medium format.

If the RTO_EN bit is set to one in the READ CAPACITY (16) parameter data (see 5.11), the device server shall terminate the command with CHECK CONDITION status with the sense key set to ILLEGAL REQUEST and the additional sense code set to INVALID COMMAND OPERATION CODE

Table 76 — WRITE SAME (16) command

Byte/Bit	7	6	5	4	3	2	1	0
0	OPERATION CODE (93h)							
1	WRPROTECT			Reserved		PBDATA	LBDATA	Reserved
2	(MSB) _____ LOGICAL BLOCK ADDRESS _____ (LSB)							
9								
10	(MSB) _____ NUMBER OF BLOCKS _____ (LSB)							
13								
14	Reserved			GROUP NUMBER				
15	CONTROL							

See the WRITE SAME (10) command (see 5.35) for the definitions of the fields in this command.

5.37 WRITE SAME (32) command

The WRITE SAME (32) command (see table 77) requests that the device server transfer a single logical block from the data-out buffer and write the contents of that logical block, with modifications based on the LBDATA bit and the PBDATA bit, to the specified range of logical block addresses. Each logical block includes user data and may include protection information, based on the WRPROTECT field and the medium format.

If the RTO_EN bit is set to zero in the READ CAPACITY (16) parameter data (see 5.11), the device server shall terminate the command with CHECK CONDITION status with the sense key set to ILLEGAL REQUEST and

the additional sense code set to INVALID COMMAND OPERATION CODE. If the RTO_EN bit is set to one, the device server may process the command.

Table 77 — WRITE SAME (32) command

Byte\Bit	7	6	5	4	3	2	1	0
0	OPERATION CODE (7Fh)							
1	CONTROL							
2	Reserved							
5	Reserved							
6	Reserved			GROUP NUMBER				
7	ADDITIONAL CDB LENGTH (18h)							
8	(MSB)	SERVICE ACTION (000Dh)						(LSB)
9								
10	WRPROTECT			Reserved		PBDATA	LBDATA	Reserved
11	Reserved							
12	(MSB)	LOGICAL BLOCK ADDRESS						(LSB)
19								
20	(MSB)	EXPECTED INITIAL LOGICAL BLOCK REFERENCE TAG						(LSB)
23								
24	(MSB)	EXPECTED LOGICAL BLOCK APPLICATION TAG						(LSB)
25								
26	(MSB)	LOGICAL BLOCK APPLICATION TAG MASK						(LSB)
27								
28	(MSB)	NUMBER OF BLOCKS						(LSB)
31								

See the WRITE SAME (10) command (see 5.35) for the definitions of the GROUP NUMBER field, the WRPROTECT field, the PBDATA bit, the LBDATA bit, the LOGICAL BLOCK ADDRESS field, and the NUMBER OF BLOCKS field.

When checking of the LOGICAL BLOCK REFERENCE TAG field is enabled (see table 63 in 5.25), the EXPECTED INITIAL LOGICAL BLOCK REFERENCE TAG field contains the value of the LOGICAL BLOCK REFERENCE TAG field expected in the protection information of the first logical block accessed by the command instead of a value based on the LBA (see 4.16.2).

If the ATO bit is set to one in the Control mode page (see SPC-4) and checking of the LOGICAL BLOCK APPLICATION TAG field is enabled (see table 63 in 5.25), the LOGICAL BLOCK APPLICATION TAG MASK field contains a value that is a bit mask for enabling the checking of the LOGICAL BLOCK APPLICATION TAG field in the protection information for each logical block accessed by the command. A LOGICAL BLOCK APPLICATION TAG MASK bit set to one enables the checking of the corresponding bit of the EXPECTED LOGICAL BLOCK APPLICATION TAG field with the corresponding bit of the LOGICAL BLOCK APPLICATION TAG field in the protection information.

If the ATO bit is set to one in the Control mode page (see SPC-4) and checking of the LOGICAL BLOCK APPLICATION TAG field is disabled (see table 63 in 5.25), or if the ATO bit is set to zero, the LOGICAL BLOCK APPLICATION TAG MASK field and the EXPECTED LOGICAL BLOCK APPLICATION TAG field shall be ignored.

5.38 XDREAD (10) command

The XDREAD (10) command (see table 78) requests that the device transfer to the data-in buffer the XOR data generated by an XDWRITE command (see 5.40 and 5.41). XOR data includes user data and may include protection information, based on the XORPINFO bit and the medium format.

Table 78 — XDREAD (10) command

Byte\Bit	7	6	5	4	3	2	1	0
0	OPERATION CODE (52h)							
1	Reserved							XORPINFO
2	(MSB)	LOGICAL BLOCK ADDRESS						(LSB)
5	Reserved			GROUP NUMBER				
6	(MSB)	TRANSFER LENGTH						(LSB)
7	CONTROL							
8								
9								

See the PRE-FETCH (10) command (see 5.3) and 4.17 for the definition of the GROUP NUMBER field.

If the XOR protection information (XORPINFO) bit is set to zero, the device server shall not check or transmit protection information.

If the XORPINFO bit is set to one, the device server supports protection information, and the medium has been formatted with protection information, the device server shall transmit protection information but shall not check any of the protection information fields.

If the XORPINFO bit is set to one, the device server supports protection information, and the medium has not been formatted with protection information, the device server shall terminate the command with CHECK CONDITION status with the sense key set to ILLEGAL REQUEST and the additional sense code set to INVALID FIELD IN CDB.

If the XORPINFO bit is set to one and the device server does not support protection information, the device server should terminate the command with CHECK CONDITION status with the sense key set to ILLEGAL REQUEST and the additional sense code set to INVALID FIELD IN CDB.

The XOR data transferred is identified by the LOGICAL BLOCK ADDRESS field and the TRANSFER LENGTH field. The LOGICAL BLOCK ADDRESS field and TRANSFER LENGTH field shall be the same as, or a subset of, those specified in a prior XDWRITE command. If a match is not found the device server shall terminate the command with CHECK CONDITION status with the sense key set to ILLEGAL REQUEST and the additional sense code set to INVALID FIELD IN CDB. The TRANSFER LENGTH field is constrained by the MAXIMUM TRANSFER LENGTH field in the Block Limits VPD page (see 6.4.2).

5.39 XDREAD (32) command

The XDREAD (32) command (see table 79) requests that the device transfer to the data-in buffer the XOR data generated by an XDWRITE command (see 5.40 and 5.41). XOR data includes user data and may include protection information, based on the XORPINFO bit and the medium format.

Table 79 — XDREAD (32) command

Byte/Bit	7	6	5	4	3	2	1	0
0	OPERATION CODE (7Fh)							
1	CONTROL							
2	Reserved							
5	Reserved							
6	Reserved			GROUP NUMBER				
7	ADDITIONAL CDB LENGTH (18h)							
8	(MSB)	SERVICE ACTION (0003h)						(LSB)
9	Reserved							
10	Reserved							XORPINFO
11	Reserved							
12	(MSB)	LOGICAL BLOCK ADDRESS						(LSB)
19	Reserved							
20	Reserved							
27	Reserved							
28	(MSB)	TRANSFER LENGTH						(LSB)
31	Reserved							

See the XDREAD (10) command (see 5.38) and SPC-4 for the definitions of the fields in this command.

5.40 XDWRITE (10) command

The XDWRITE (10) command (see table 80) requests that the device server:

- 1) read the specified logical block(s);
- 2) transfer logical blocks from the data-out buffer;
- 3) perform an XOR operation with the logical blocks transferred from the data-out buffer and the logical blocks read, storing the resulting XOR data in a buffer; and
- 4) if the DISABLE WRITE bit is set to zero, write the logical blocks transferred from the data-out buffer.

Each logical block includes user data and may include protection information, based on the WRPROTECT field and the medium format. The resulting XOR data shall be retained as specified in 4.14.4.

If the RTO_EN bit is set to one in the READ CAPACITY (16) parameter data (see 5.11), the device server shall terminate the command with CHECK CONDITION status with the sense key set to ILLEGAL REQUEST and the additional sense code set to INVALID COMMAND OPERATION CODE.

Table 80 — XDWRITE (10) command

Byte\Bit	7	6	5	4	3	2	1	0
0	OPERATION CODE (50h)							
1	WRPROTECT			DPO	FUA	DISABLE WRITE	FUA_NV	Reserved
2	(MSB) _____ LOGICAL BLOCK ADDRESS _____ (LSB)							
5	_____ (LSB)							
6	Reserved			GROUP NUMBER				
7	(MSB) _____ TRANSFER LENGTH _____ (LSB)							
8	_____ (LSB)							
9	CONTROL							

See the WRITE (10) command (see 5.25) for the definitions of the WRPROTECT field, the FUA bit, and the FUA_NV bit. See the READ (10) command (see 5.6) for the definition of the DPO bit. See the PRE-FETCH (10) command (see 5.3) for the definition of the LOGICAL BLOCK ADDRESS field. See the PRE-FETCH (10) command (see 5.3) and 4.17 for the definition of the GROUP NUMBER field.

A DISABLE WRITE bit set to zero specifies that the data transferred from the data-out buffer shall be written to the medium after the XOR operation is complete. A DISABLE WRITE bit set to one specifies that the data shall not be written to the medium.

The TRANSFER LENGTH field specifies the number of contiguous logical blocks of data that read, transferred from the data-out buffer, and XORed into a buffer, starting with the logical block specified by the LOGICAL BLOCK ADDRESS field. If the logical block address plus the transfer length exceeds the capacity of the medium, the device server shall terminate the command with CHECK CONDITION status with the sense key set to ILLEGAL REQUEST and the additional sense code set to LOGICAL BLOCK ADDRESS OUT OF RANGE. The TRANSFER LENGTH field is constrained by the MAXIMUM TRANSFER LENGTH field in the Block Limits VPD page (see 6.4.2).

The resulting XOR data is retrieved by an XDREAD command (see 5.38 and 5.39) with starting LOGICAL BLOCK ADDRESS field and TRANSFER LENGTH field that match, or are a subset of, the LOGICAL BLOCK ADDRESS field and TRANSFER LENGTH field of this command.

5.41 XDWRITE (32) command

The XDWRITE (32) command (see table 81) requests that the device server:

- 1) read the specified logical block(s);
- 2) transfer logical blocks from the data-out buffer;
- 3) perform an XOR operation with the logical blocks transferred from the data-out buffer and the logical blocks read, storing the resulting XOR data in a buffer; and
- 4) if the DISABLE WRITE bit is set to zero, write the logical blocks transferred from the data-out buffer.

Each logical block includes user data and may include protection information, based on the WRPROTECT field and the medium format. The resulting XOR data shall be retained as specified in 4.14.4.

If the RTO_EN bit is set to one in the READ CAPACITY (16) parameter data (see 5.11), the device server shall terminate this command with CHECK CONDITION status with the sense key set to ILLEGAL REQUEST and the additional sense code set to INVALID COMMAND OPERATION CODE.

Table 81 — XDWRITE (32) command

Byte\Bit	7	6	5	4	3	2	1	0
0	OPERATION CODE (7Fh)							
1	CONTROL							
2	Reserved							
5	Reserved							
6	Reserved			GROUP NUMBER				
7	ADDITIONAL CDB LENGTH (18h)							
8	(MSB)	SERVICE ACTION (0004h)						(LSB)
9	Reserved							
10	WRPROTECT			DPO	FUA	DISABLE WRITE	FUA_NV	Reserved
11	Reserved							
12	(MSB)	LOGICAL BLOCK ADDRESS						(LSB)
19	Reserved							
20	Reserved							
27	Reserved							
28	(MSB)	TRANSFER LENGTH						(LSB)
31	Reserved							

See the XDWRITE (10) command (see 5.40) and SPC-4 for the definitions of the fields in this command.

5.42 XDWRITEREAD (10) command

The XDWRITEREAD (10) command (see table 82) requests that the device server:

- 1) read the specified logical block(s);
- 2) transfer logical blocks from the data-out buffer;
- 3) XOR the logical blocks transferred from the data-out buffer with the logical blocks read, storing the resulting XOR data in a buffer;
- 4) if the DISABLE WRITE bit is set to zero, write the logical blocks transferred from the data-out buffer; and
- 5) transfer the resulting XOR data to the data-in buffer.

Each logical block includes user data and may include protection information, based on the WRPROTECT field, the XORPINFO bit, and the medium format. This command is equivalent to an XDWRITE (10) command (see 5.40) followed by an XDREAD (10) command (see 5.38) specifying the same values for the GROUP NUMBER field, the LOGICAL BLOCK ADDRESS field, and the TRANSFER LENGTH field. This command is only available on transport protocols supporting bidirectional commands.

If the RTO_EN bit is set to one in the READ CAPACITY (16) parameter data (see 5.11), the device server shall terminate the command with CHECK CONDITION status with the sense key set to ILLEGAL REQUEST and the additional sense code set to INVALID COMMAND OPERATION CODE.

Table 82 — XDWRITEREAD (10) command

Byte\Bit	7	6	5	4	3	2	1	0
0	OPERATION CODE (53h)							
1	WRPROTECT			DPO	FUA	DISABLE WRITE	FUA_NV	XORPINFO
2	(MSB)	LOGICAL BLOCK ADDRESS						(LSB)
5								
6	Reserved			GROUP NUMBER				
7	(MSB)	TRANSFER LENGTH						(LSB)
8								
9	CONTROL							

See the XDWRITE (10) command (see 5.40) and XDREAD (10) command (see 5.38) for the definitions of the fields in this command.

5.43 XDWRITEREAD (32) command

The XDWRITEREAD (32) command (see table 83) requests that the device server:

- 1) read the specified logical block(s);
- 2) transfer logical blocks from the data-out buffer;
- 3) XOR the logical blocks transferred from the data-out buffer with the logical blocks read, storing the resulting XOR data in a buffer;
- 4) if the DISABLE WRITE bit is set to zero, write the logical blocks transferred from the data-out buffer; and
- 5) transfer the resulting XOR data to the data-in buffer.

Each logical block includes user data and may include protection information, based on the WRPROTECT field, the XORPINFO bit, and the medium format. This command is equivalent to an XDWRITE (32) command (see 5.41) followed by an XDREAD (32) command (see 5.39) specifying the same values for the GROUP NUMBER field, the LOGICAL BLOCK ADDRESS field, and the TRANSFER LENGTH field. This command is only available on transport protocols supporting bidirectional commands.

If the RTO_EN bit is set to one in the READ CAPACITY (16) parameter data (see 5.11), the device server shall terminate the command with CHECK CONDITION status with the sense key set to ILLEGAL REQUEST and the additional sense code set to INVALID COMMAND OPERATION CODE.

Table 83 — XDWRITEREAD (32) command

Byte\Bit	7	6	5	4	3	2	1	0
0	OPERATION CODE (7Fh)							
1	CONTROL							
2	Reserved							
5	Reserved							
6	Reserved			GROUP NUMBER				
7	ADDITIONAL CDB LENGTH (18h)							
8	(MSB)	SERVICE ACTION (0007h)						(LSB)
9	Reserved							
10	WRPROTECT			DPO	FUA	DISABLE WRITE	FUA_NV	XORPINFO
11	Reserved							
12	(MSB)	LOGICAL BLOCK ADDRESS						(LSB)
19	Reserved							
20	Reserved							
27	Reserved							
28	(MSB)	TRANSFER LENGTH						(LSB)
31	Reserved							

See the XDWRITEREAD (10) command (see 5.42) and SPC-4 for the definitions of the fields in this command.

5.44 XPWRITE (10) command

The XPWRITE (10) command (see table 84) requests that the device server:

- 1) read the specified logical block(s);
- 2) transfer logical blocks from the data-out buffer; and
- 3) XOR the logical blocks transferred from the data-out buffer with the logical blocks read, writing the resulting XOR data.

Each logical block includes user data and may include protection information, based on the XORPINFO bit and the medium format.

Table 84 — XPWRITE (10) command

Byte\Bit	7	6	5	4	3	2	1	0
0	OPERATION CODE (51h)							
1	Reserved			DPO	FUA	Reserved	FUA_NV	XORPINFO
2	(MSB) LOGICAL BLOCK ADDRESS (LSB)							
5								
6	Reserved			GROUP NUMBER				
7	(MSB) TRANSFER LENGTH (LSB)							
8								
9	CONTROL							

See the READ (10) command (see 5.6) for the definition of the DPO bit. See the WRITE (10) command (see 5.25) for the definitions of the FUA bit and the FUA_NV bit. See the PRE-FETCH (10) command (see 5.3) for the definition of the LOGICAL BLOCK ADDRESS field. See the PRE-FETCH (10) command (see 5.3) and 4.17 for the definition of the GROUP NUMBER field.

If the XOR protection information (XORPINFO) bit is set to zero, the device server supports protection information, and the medium has been formatted with protection information, the device server shall terminate the command with CHECK CONDITION status with the sense key set to ILLEGAL REQUEST and the additional sense code set to INVALID FIELD IN CDB.

If the XORPINFO bit is set to one, the device server supports protection information, and the medium has been formatted with protection information, the device server shall XOR the user data and protection information transferred from the data-out buffer with the user data and protection information read, and then write the resulting XOR data. The device server shall not check any of the protection information fields.

If the XORPINFO bit is set to one, the device server supports protection information, and the medium has not been formatted with protection information, the device server shall terminate the command with CHECK CONDITION status with the sense key set to ILLEGAL REQUEST and the additional sense code set to INVALID FIELD IN CDB.

If the XORPINFO bit is set to one and the device server does not support protection information, the device server should terminate the command with CHECK CONDITION status with the sense key set to ILLEGAL REQUEST and the additional sense code set to INVALID FIELD IN CDB.

The TRANSFER LENGTH field specifies the number of contiguous logical blocks that shall be read, XORed with logical blocks transferred from the data-out buffer, and written, starting with the logical block specified by the LOGICAL BLOCK ADDRESS field. If the logical block address plus the transfer length exceeds the capacity of the medium, the device server shall terminate the command with CHECK CONDITION status with the sense key set to ILLEGAL REQUEST and the additional sense code set to LOGICAL BLOCK ADDRESS OUT OF RANGE. The TRANSFER LENGTH field is constrained by the MAXIMUM TRANSFER LENGTH field in the Block Limits VPD page (see 6.4.2).

5.45 XPWRITE (32) command

The XPWRITE (32) command (see table 85) requests that the device server:

- 1) read the specified logical block(s);
- 2) transfer logical blocks from the data-out buffer; and
- 3) XOR the logical blocks transferred from the data-out buffer with the logical blocks read, writing the resulting XOR data.

Each logical block includes user data and may include protection information, based on the XORPINFO bit and the medium format.

Table 85 — XPWRITE (32) command

Byte\Bit	7	6	5	4	3	2	1	0
0	OPERATION CODE (7Fh)							
1	CONTROL							
2	Reserved							
5	Reserved							
6	Reserved			GROUP NUMBER				
7	ADDITIONAL CDB LENGTH (18h)							
8	(MSB)	SERVICE ACTION (0006h)						(LSB)
9	Reserved							
10	Reserved			DPO	FUA	Reserved	FUA_NV	XORPINFO
11	Reserved							
12	(MSB)	LOGICAL BLOCK ADDRESS						(LSB)
19	Reserved							
20	Reserved							
27	Reserved							
28	(MSB)	TRANSFER LENGTH						(LSB)
31	Reserved							

See the XPWRITE (10) command (see 5.44) and SPC-4 for the definitions of the fields in this command.

6 Parameters for direct-access block devices

6.1 Diagnostic parameters

6.1.1 Diagnostic parameters overview

This subclause defines the descriptors and pages for diagnostic parameters used with direct-access block devices. The diagnostic page codes for direct-access block devices are defined in table 86.

Table 86 — Diagnostic page codes

Diagnostic page code	Description	Reference
00h	Supported diagnostic pages	SPC-4
01h - 2Fh	SCSI enclosure services diagnostic pages	SES-2
30h - 3Fh	Diagnostic pages assigned by SPC-4	SPC-4
40h	Translate Address Output diagnostic page	6.1.2
	Translate Address Input diagnostic page	6.1.3
41h	Obsolete (Device Status diagnostic pages)	
42h - 7Fh	Reserved for this standard	
80h - FFh	Vendor-specific diagnostic pages	

6.1.2 Translate Address Output diagnostic page

The Translate Address diagnostic pages allow the application client to translate an address in one of the formats supported by the FORMAT UNIT command (see 5.2.2.4) (i.e., a short block format address, a long block format address, a physical sector format address, or a bytes from index format address) into any one of the other formats. The address to be translated is sent to the device server with the SEND DIAGNOSTIC command and the results are returned to the application client by the RECEIVE DIAGNOSTIC RESULTS command.

Table 87 defines the format of the Translate Address Output diagnostic page sent with the SEND DIAGNOSTIC command. The translated address is returned in the Translate Address Input diagnostic page (see 6.1.3).

Table 87 — Translate Address Output diagnostic page

Byte\Bit	7	6	5	4	3	2	1	0
0	PAGE CODE (40h)							
1	Reserved							
2	(MSB)	PAGE LENGTH (000Ah)						(LSB)
3								
4	Reserved				SUPPLIED FORMAT			
5	Reserved				TRANSLATE FORMAT			
6	(MSB)	ADDRESS TO TRANSLATE						(LSB)
13								

The SUPPLIED FORMAT field specifies the format of the ADDRESS TO TRANSLATE field. Valid values for this field are defined in the DEFECT LIST FORMAT field of the FORMAT UNIT command (see 5.2). If the device server does not support the requested format it shall terminate the SEND DIAGNOSTIC command with CHECK

CONDITION status with the sense key set to ILLEGAL REQUEST and the additional sense code set to INVALID FIELD IN PARAMETER LIST.

The TRANSLATE FORMAT field specifies the format the device server shall use for the result of the address translation. Valid values for this field are defined in the DEFECT LIST FORMAT field of the FORMAT UNIT command. If the device server does not support the specified format it shall terminate the SEND DIAGNOSTIC command with CHECK CONDITION status with the sense key set to ILLEGAL REQUEST and the additional sense code set to INVALID FIELD IN PARAMETER LIST.

The ADDRESS TO TRANSLATE field contains a single address descriptor which the application client is requesting the device server to translate. The format of this field depends on the value in the SUPPLIED FORMAT field. The formats are described in 5.2.2.4. If the short block format address descriptor is specified, the first four bytes of the ADDRESS TO TRANSLATE field shall contain the short block format address descriptor and the last four bytes shall contain 00000000h.

6.1.3 Translate Address Input diagnostic page

Table 88 defines the Translate Address Input diagnostic page retrieved with the RECEIVE DIAGNOSTIC RESULTS command after the Translate Address Output diagnostic page (see 6.1.2) has been sent with the SEND DIAGNOSTIC command. If a Translate Address Output diagnostic page has not yet been processed, the results of a RECEIVE DIAGNOSTIC RESULTS command requesting this diagnostic page are vendor-specific.

Table 88 — Translate Address Input diagnostic page

Byte\Bit	7	6	5	4	3	2	1	0
0	PAGE CODE (40h)							
1	Reserved							
2	(MSB) PAGE LENGTH (n - 3) (LSB)							
3								
4	Reserved				SUPPLIED FORMAT			
5	RAREA	ALTSEC	ALTTRK	Reserved		TRANSLATED FORMAT		
Translated address(es)								
6	(MSB) TRANSLATED ADDRESS 1 (LSB)							
13								
...								
n - 7	(MSB) TRANSLATED ADDRESS x (if required) (LSB)							
n								

The Translate Address Input diagnostic page contains a four-byte page header that specifies the page code and length followed by two bytes that describe the translated address followed by zero or more translated addresses.

The PAGE LENGTH field contains the number of parameter bytes that follow.

The SUPPLIED FORMAT field contains the value from the SUPPLIED FORMAT field in the previous Translate Address Output diagnostic page (see 6.1.2).

A reserved area (RAREA) bit set to zero indicates that no part of the translated address falls within a reserved area of the medium. A RAREA bit set to one indicates that all or part of the translated address falls within a reserved area of the medium (e.g., speed tolerance gap, alternate sector, or vendor reserved area). If the entire translated address falls within a reserved area, the device server may not return a translated address.

An alternate sector (ALTSEC) bit set to zero indicates that no part of the translated address is located in an alternate sector of the medium or that the device server is unable to determine this information. An ALTSEC bit set to one indicates that the translated address is physically located in an alternate sector of the medium. If the device server is unable to determine if all or part of the translated address is located in an alternate sector it shall set this bit to zero.

An alternate track (ALTRK) bit set to zero indicates that no part of the translated address is located on an alternate track of the medium. An ALTRK bit set to one indicates that part or all of the translated address is located on an alternate track of the medium or the device server is unable to determine if all or part of the translated address is located on an alternate track.

The TRANSLATED FORMAT field contains the value from the TRANSLATE FORMAT field in the previous Translate Address Output diagnostic page (see 6.1.2).

The TRANSLATED ADDRESS field(s) contains the address(es) the device server translated from the address supplied by the application client in the previous Translate Address Output diagnostic page. Each field shall be in the format specified in the TRANSLATE FORMAT field. The formats are described in 5.2.2.4. If the short block format address descriptor is specified, the first four bytes of the TRANSLATED ADDRESS field shall contain the short block format address descriptor and the last four bytes shall contain 0000000h.

If the returned data is in short block format, long block format, or physical sector format and the ADDRESS TO TRANSLATE field in the previous Translate Address Output diagnostic page covers more than one address after it has been translated (e.g., because of multiple physical sectors within a single logical block or multiple logical blocks within a single physical sector) the device server shall return all possible addresses that are contained in the area specified by the address to be translated. If the returned data is in bytes from index format, the device server shall return a pair of translated values for each of the possible addresses that are contained in the area specified by the ADDRESS TO TRANSLATE field in the previous Translate Address Output diagnostic page. Of the pair of translated values returned, the first indicates the starting location and the second the ending location of the area.

6.2 Log parameters

6.2.1 Log parameters overview

This subclause defines the descriptors and pages for log parameters used with direct-access block devices. See SPC-4 for a detailed description of logging operations. The log page codes for direct-access block devices are defined in table 89.

Table 89 — Log page codes

Log page code	Description	Reference
00h	Supported Log Pages log page	SPC-4
01h	Buffer Over-Run/Under-Run log page	SPC-4
02h	Write Error Counter log page	SPC-4
03h	Read Error Counter log page	SPC-4
04h	Reserved	
05h	Verify Error Counter log page	SPC-4
06h	Non-Medium Error log page	SPC-4
07h	Last n Error Events log page	SPC-4
08h	Format Status log page	6.2.3
09h	Restricted (see SPC-4)	
0Ah	Restricted (see SPC-4)	
0Bh	Last n Deferred Errors Or Asynchronous Events log page	SPC-4
0Ch	Reserved	
0Dh	Temperature log page	SPC-4
0Eh	Start-Stop Cycle Counter log page	SPC-4
0Fh	Application Client log page	SPC-4
10h	Self-Test Results log page	SPC-4
11h - 14h	Reserved	
15h	Background Scan Results log page	6.2.2
16h	Reserved	
17h	Non-volatile Cache log page	6.2.4
18h	Protocol-Specific Port log page	SPC-4
19h - 2Eh	Reserved	
2Fh	Informational Exceptions log page	SPC-4
30h - 3Eh	Vendor-specific	
3Fh	Reserved	

6.2.2 Background Scan Results log page

The Background Scan Results log page (see table 90) returns the background scanning status parameter and zero or more medium scan parameters when background scanning is supported. The background scanning status parameter provides information about background pre-scan and background medium scan operations. Each medium error log entry corresponds to a logical block where an error was detected. If the medium scan

log area is filled up, a new medium scan log entry overwrites the oldest entry. When a LOG SELECT command with PCR bit set to one is processed all medium scan parameters are deleted, however the values in the background scanning status parameter shall not be affected.

Table 90 — Background Scan Results log page

Byte\Bit	7	6	5	4	3	2	1	0
0	Reserved		PAGE CODE (15h)					
1	Reserved							
2	(MSB)	PAGE LENGTH (n - 3)						(LSB)
3								
	Background scan results parameters							
4	Background scanning status parameters							
19								
20	(MSB)	First medium scan parameter						(LSB)
43								
	.							
	.							
	.							
n-23	(MSB)	Last medium scan parameter						(LSB)
n								

Table 91 defines the parameter codes for the Background Scan Results log page.

Table 91 — Background Scan Results log page parameter codes

Parameter code	Description
0000h	Background scanning status
0001h - 0800h	Medium scan
07FFh - 7FFFh	Reserved

The background scanning status parameter (see table 92) contains status information about the background pre-scan and background medium scan features.

Table 92 — Background scanning status parameter format

Byte\Bit	7	6	5	4	3	2	1	0
0	(MSB) _____							
1	PARAMETER CODE (0000h) _____ (LSB)							
2	DU	DS	TSD	ETC	TMC		LBIN	LP
3	PARAMETER LENGTH (0Ch)							
4	(MSB) _____							
7	POWER ON MINUTES _____ (LSB)							
8	Reserved							
9	BACKGROUND SCANNING STATUS							
10	NUMBER OF SCANS PERFORMED _____							
11								
12	(MSB) _____							
13	MEDIUM SCAN PROGRESS _____ (LSB)							
14	Reserved							
15								

The contents of the DU, DS, TSD, ETC, LBIN, and LP bits and the TMC field are defined in SPC-4.

The PARAMETER LENGTH field indicates the number of bytes remaining in the log parameter.

The POWER ON MINUTES field indicates the total power on minutes at the time the log page is requested.

Table 93 specifies the meaning of the BACKGROUND SCANNING STATUS field.

Table 93 — BACKGROUND SCANNING STATUS field

Code	Description
00h	No scans active
01h	Background medium scan is active
02h	Pre-scan is active
03h	Scan halted due to fatal error
04h	Scan halted due to a vendor specific pattern of errors
05h	Scan halted due to medium formatted without P-list
06h	Scan halted - vendor specific cause
07h	Scan halted due to temperature out of allowed range
08h	Scan suspended until BMS interval time (see 6.3.3) expires
09h - FFh	Reserved

The NUMBER OF SCANS PERFORMED field indicates the number of background scans that have been performed since the SCSI target device was originally shipped by the manufacturer.

The MEDIUM SCAN PROGRESS field is a percent complete indication of the medium scan. The returned value is a numerator that has 65 536 (10000h) as its denominator.

A medium scan parameter (see table 94) describes a defect location on the medium that was encountered by background scanning.

Table 94 — Medium scan parameter format

Byte\Bit	7	6	5	4	3	2	1	0
0	(MSB) _____							
1	PARAMETER CODE (0001h - 0800h) _____ (LSB)							
2	DU	DS	TSD	ETC	TMC	LBIN	LP	
3	PARAMETER LENGTH (14h)							
4	(MSB) _____							
7	POWER ON MINUTES _____ (LSB)							
8	REASSIGN STATUS				SENSE KEY			
9	ADDITIONAL SENSE CODE							
10	ADDITIONAL SENSE CODE QUALIFIER							
11	_____							
15	VENDOR SPECIFIC _____							
16	(MSB) _____							
23	LBA _____ (LSB)							

The contents of the DU, DS, TSD, ETC, LBIN, and LP bits and the TMC field are defined in SPC-4.

The PARAMETER LENGTH field indicates the number of bytes remaining in the log parameter.

The POWER ON MINUTES field indicates the total power on minutes at the time the error was detected.

Table 95 specifies the REASSIGN STATUS field.

Table 95 — REASSIGN STATUS field

Code	Description
0h	no reassignment needed
1h	Reassignment pending receipt of a write command if automatic write reallocation is enabled or a REASSIGN BLOCKS command,
2h	LBA successfully reassigned
3h	Reserved
4h	Reassign failed
5h	LBA recovered via re-write
6h - Fh	Reserved

The SENSE KEY field, ADDITIONAL SENSE CODE field, and the ADDITIONAL SENSE CODE QUALIFIER field may contain a hierarchy of additional information relating to error conditions that occurred during background scanning. They are represented in the same format used by the sense data (see SPC-4).

The LBA field indicates the logical block address associated with the medium error.

6.2.3 Format Status log page

The Format Status log page (log page code 08h) captures the state of the direct-access block device since the most recent successful FORMAT UNIT command (see 5.2) was completed. Additionally, this log page provides Defect Management information for the device server.

The Format Status log page uses the log page format defined in SPC-4.

Table 96 defines the parameter codes for the Format Status log page.

Table 96 — Format Status log page parameter codes

Parameter code	Description
0000h	Format Data Out
0001h	Grown Defects During Certification
0002h	Total Blocks Reallocated During Format
0003h	Total New Blocks Reallocated
0004h	Power On Minutes Since Format
0005h - 7FFFh	Reserved
8000h - FFFFh	Vendor-specific

The PARAMETER LENGTH field of each log parameter (see SPC-4) contains the length of the corresponding PARAMETER VALUE field and is vendor-specific.

Event counts are returned as a result of the LOG SENSE command. The default value for each event count listed table 96 shall be zero. Attempts to change these event counts by issuing a LOG SELECT with these fields set to non-zero values is not considered an error and shall have no effect on the saved values.

If information about a log parameter is not available, the device server shall return a value with each byte set to FFh (e.g., if the PARAMETER LENGTH field is set to 02h, the PARAMETER VALUE field is set to FFFFh). If the most recent FORMAT UNIT command failed, the device server shall return a value with each byte set to FFh for each log parameter.

The Format Data Out parameter contains the entire FORMAT UNIT parameter list (see 5.2.2) from the most recent successful FORMAT UNIT command. This includes:

- a) the parameter list header;
- b) the initialization pattern descriptor, if any; and
- c) the defect list, if any.

The Grown Defects During Certification parameter is a count of the number of defects detected as a result of performing certification during processing of the most recent successful FORMAT UNIT command. This count reflects only those defects detected and replaced that were not already part of the PLIST or GLIST. If a certification pass was not performed the GROWN DEFECTS DURING CERTIFICATION field shall be set to zero.

The Total Blocks Reallocated During Format parameter is a count of the total number of logical blocks that were reallocated during the most recent successful FORMAT UNIT command.

The Total New Blocks Reallocated parameter is a count of the total number of logical blocks that have been reallocated since the completion of the most recent successful FORMAT UNIT command.

The Power On Minutes Since Format parameter represents the unsigned number of usage minutes (i.e., minutes with power applied regardless of power state) that have elapsed since the most recent successful FORMAT UNIT command.

Upon receiving the FORMAT UNIT command, the device server should set all parameters within the Format Status log page to indicate that no such information is available. Only upon successful completion of the FORMAT UNIT command should the device server update the affected fields.

The target save disable (TSD) bit in the PARAMETER CONTROL byte (see SPC-4) shall always be set to zero to indicate that the device server provides an implicit saving frequency.

NOTE 23 - Removable media device servers may save log page information with the medium in a vendor-specific manner and location.

6.2.4 Non-volatile Cache log page

The Non-volatile Cache log page (see table 97) indicates the status of battery backup for a non-volatile cache.

Table 97 — Non-volatile Cache log page

Byte\Bit	7	6	5	4	3	2	1	0
0	Reserved		PAGE CODE (17h)					
1	Reserved							
2	(MSB)	PAGE LENGTH (n - 3)						(LSB)
3								
4	Non-volatile cache log parameters							
n								

Table 98 defines the parameter codes.

Table 98 — Non-volatile Cache log parameters

Parameter code	Description
0000h	Remaining Non-volatile Time
0001h	Maximum Non-volatile Time
All others	Reserved

The Remaining Non-volatile Time parameter has the format shown in table 99.

Table 99 — Remaining Non-volatile Time parameter data

Byte\Bit	7	6	5	4	3	2	1	0
0	PARAMETER LENGTH (3h)							
1	(MSB)	REMAINING NON-VOLATILE TIME						(LSB)
3								

The REMAINING NON-VOLATILE TIME field is defined in table 100.

Table 100 — REMAINING NON-VOLATILE TIME field

Code	Description
000000h	Non-volatile cache is volatile, either permanently or temporarily (e.g., if batteries need to be recharged).
000001h	Non-volatile cache is expected to remain non-volatile for an unknown amount of time (e.g., if battery status is unknown)
000002h to FFFFFFFEh	Non-volatile cache is expected to remain non-volatile for the number of minutes indicated (e.g., battery-backed random access memory).
FFFFFFFh	Non-volatile cache is indefinitely non-volatile.

The Maximum Non-volatile Time parameter has the format shown in table 101.

Table 101 — Maximum Non-volatile Time parameter data

Byte\Bit	7	6	5	4	3	2	1	0	
0	PARAMETER LENGTH (3h)								
1	(MSB)	MAXIMUM NON-VOLATILE TIME							
3								(LSB)	

The MAXIMUM NON-VOLATILE TIME field is defined in table 102.

Table 102 — MAXIMUM NON-VOLATILE TIME field

Code	Description
000000h	Non-volatile cache is volatile
000001h	Reserved
000002h to FFFFFFFEh	Non-volatile cache is capable of being non-volatile for the estimated number of minutes indicated. If the time is based on batteries, it shall be based on the last full charge capacity rather than the design capacity of the batteries.
FFFFFFFh	Non-volatile cache is indefinitely non-volatile.

6.3 Mode parameters

6.3.1 Mode parameters overview

This subclause defines the block descriptors and mode pages used with direct-access block devices.

The mode parameter list, including the mode parameter header, is described in SPC-4. Direct-access block devices support zero or one mode parameter block descriptors (i.e., the block descriptor is shared by all the logical blocks on the medium).

The MEDIUM TYPE field in the mode parameter header (see SPC-4) shall be set to 00h.

The DEVICE-SPECIFIC PARAMETER field in the mode parameter header (see SPC-4) is defined for direct-access block devices in table 103.

Table 103 — DEVICE-SPECIFIC PARAMETER field for direct-access block devices

Bit	7	6	5	4	3	2	1	0
	WP	Reserved		DPOFUA	Reserved			

When used with the MODE SELECT command, the write protect (WP) bit is not defined.

When used with the MODE SENSE command, a WP bit set to one indicates that the medium is write-protected. A WP bit set to zero indicates that the medium is not write-protected. When the software write protect (SWP) bit in the Control mode page (see SPC-4) is set to one, the WP bit shall be set to one. When the SWP bit in the Control mode page is set to zero, the WP bit shall be set to one if the medium is write-protected (e.g., due to mechanisms outside the scope of this standard) or zero if the medium is not write-protected.

When used with the MODE SELECT command, the DPOFUA bit is reserved.

When used with the MODE SENSE command, a DPOFUA bit set to zero indicates that the device server does not support the DPO and FUA bits. When used with the MODE SENSE command, a DPOFUA bit set to one indicates that the device server supports the DPO and FUA bits (see 4.10).

The mode page codes and subpage codes for direct-access block devices are shown in table 104.

Table 104 — Mode page codes for direct-access block devices

Mode page code	Description	Reference
00h	Vendor-specific (does not require page format)	
00h-3Eh/FFh	Return all subpages ^a	SPC-4
01h	Read-Write Error Recovery mode page	6.3.5
02h	Disconnect-Reconnect mode page	SPC-4
03h	Obsolete (Format Device mode page)	
04h	Obsolete (Rigid Disk Geometry mode page)	
05h	Obsolete (Flexible Disk mode page)	
06h	Reserved	
07h	Verify Error Recovery mode page	6.3.6
08h	Caching mode page	6.3.4
09h	Obsolete	
0Ah/00h	Control mode page	SPC-4
0Ah/01h	Control Extension mode page	SPC-4
0Ah/02h - 3Eh	Reserved	
0Bh	Obsolete (Medium Types Supported mode page)	
0Ch	Obsolete (Notch And Partition mode page)	
0Dh	Obsolete	
0Eh - 0Fh	Reserved	
10h	XOR Control mode page	6.3.7
11h - 13h	Reserved	
14h	Enclosure Services Management mode page ^b	SES-2
15h - 17h	Reserved	
18h	Protocol-Specific LUN mode page	SPC-4
19h	Protocol-Specific Port mode page	SPC-4
1Ah	Power Condition mode page	SPC-4
1Bh	Reserved	
1Ch/00h	Informational Exceptions Control mode page	SPC-4
1Ch/01h	Background Control mode page	6.3.3
1Dh - 1Fh	Reserved	
20h - 3Eh	Vendor-specific (does not require page format)	
3Fh/00h	Return all mode pages ^a	SPC-4
3Fh/01h - 3Eh	Reserved	
3Fh/FFh	Return all mode pages and subpages ^a	SPC-4
^a Valid only for the MODE SENSE command		
^b Valid only if the ENCSERV bit is set to one in the standard INQUIRY data (see SPC-4)		

6.3.2 Mode parameter block descriptors

6.3.2.1 Mode parameter block descriptors overview

If the device server returns a mode parameter block descriptor, it shall return a short LBA mode parameter block descriptor (see 6.3.2.2) in the mode parameter data in response to:

- a) a MODE SENSE (6) command; or
- b) a MODE SENSE (10) command with the LLBAA bit set to zero.

If the device server returns a mode parameter block descriptor and the number of blocks is greater than FFFFFFFh, it may return a long LBA mode parameter block descriptor (see 6.3.2.3) in the mode parameter data in response to a MODE SENSE (10) command with the LLBAA bit set to one.

If the application client sends a mode parameter block descriptor in the mode parameter list, it shall send a short LBA mode parameter block descriptor (see 6.3.2.2) for a MODE SELECT (6) command.

If the application client sends a mode parameter block descriptor in the mode parameter list, it may send a long LBA mode parameter block descriptor (see 6.3.2.3) for a MODE SELECT (10) command.

Support for the mode parameter block descriptors is optional. The device server shall establish a unit attention condition with the additional sense code of MODE PARAMETERS CHANGED (see SPC-4 and SAM-4) when the block descriptor values are changed.

6.3.2.2 Short LBA mode parameter block descriptor

Table 105 defines the block descriptor for direct-access block devices used:

- a) with the MODE SELECT (6) and MODE SENSE (6) commands; and
- b) with the MODE SELECT (10) and MODE SENSE (10) commands when the LONGLBA bit is set to zero in the mode parameter header (see SPC-4).

Table 105 — Short LBA mode parameter block descriptor

Byte\Bit	7	6	5	4	3	2	1	0
0	(MSB) _____							
3	NUMBER OF BLOCKS							(LSB)
4	Reserved							
5	(MSB) _____							
7	BLOCK LENGTH							(LSB)

A device server shall respond to a MODE SENSE command (see SPC-4) by reporting the number of blocks specified in the NUMBER OF BLOCKS field sent in the last MODE SELECT command that contained a mode parameter block descriptor. If no MODE SELECT command with a mode parameter block descriptor has been received then the current number of blocks shall be returned. To determine the number of blocks at which the logical unit is currently formatted, the application client shall use the READ CAPACITY command (see 5.11) rather than the MODE SELECT command.

On a MODE SENSE command, the device server may return a value of zero indicating that it does not report the number of blocks in the short LBA mode parameter block descriptor.

On a MODE SENSE command, if the number of logical blocks on the medium exceeds the maximum value that is able to be specified in the NUMBER OF BLOCKS field, the device server shall return a value of FFFFFFFh.

If the logical unit does not support changing its capacity by changing the NUMBER OF BLOCKS field using the MODE SELECT command (see SPC-4), the value in the NUMBER OF BLOCKS field is ignored. If the device

supports changing its capacity by changing the NUMBER OF BLOCKS field, then the NUMBER OF BLOCKS field is interpreted as follows:

- a) If the NUMBER OF BLOCKS field is set to zero, the logical unit shall retain its current capacity if the block length has not changed. If the NUMBER OF BLOCKS field is set to zero and the content of the BLOCK LENGTH field (i.e., new block length) is different than the current block length, the logical unit shall be set to its maximum capacity when the new block length takes effect (i.e., after a successful FORMAT UNIT command);
- b) If the NUMBER OF BLOCKS field is greater than zero and less than or equal to its maximum capacity, the logical unit shall be set to that number of blocks. If the content of the BLOCK LENGTH field is the same as the current block length, the logical unit shall not become format corrupt. This capacity setting shall be retained through power cycles, hard resets, logical unit resets, and I_T nexus losses. If the content of the BLOCK LENGTH field is the same as the current block length this capacity setting shall take effect on successful completion of the MODE SELECT command. If the content of the BLOCK LENGTH field (i.e., new block length) is different than the current block length this capacity setting shall take effect when the new block length takes effect (i.e., after a successful FORMAT UNIT command);
- c) If the NUMBER OF BLOCKS field is set to a value greater than the maximum capacity of the device and less than FFFFFFFFh, then the MODE SELECT command shall be terminated with CHECK CONDITION status with the sense key set to ILLEGAL REQUEST and the additional sense code set to INVALID FIELD IN PARAMETER LIST. The logical unit shall retain its previous block descriptor settings; or
- d) If the NUMBER OF BLOCKS field is set to FFFFFFFFh, the logical unit shall be set to its maximum capacity. If the content of the BLOCK LENGTH field is the same as the current block length, the logical unit shall not become format corrupt. This capacity setting shall be retained through power cycles, hard resets, logical unit resets, and I_T nexus losses. If the content of the BLOCK LENGTH field is the same as the current block length this capacity setting shall take effect on successful completion of the MODE SELECT command. If the content of the BLOCK LENGTH field (i.e., new block length) is different than the current block length this capacity setting shall take effect when the new block length takes effect (i.e., after a successful FORMAT UNIT command).

The BLOCK LENGTH field specifies the length in bytes of each logical block. No change shall be made to any logical blocks on the medium until a format operation (see 5.2) is initiated by an application client.

A device server shall respond to a MODE SENSE command (see SPC-4) by reporting the length of the logical blocks as specified in the BLOCK LENGTH field sent in the last MODE SELECT command that contained a mode parameter block descriptor. If no MODE SELECT command with a block descriptor has been received then the current block length shall be returned (e.g., if the block length is 512 bytes and a MODE SELECT command occurs with the BLOCK LENGTH field set to 520 bytes, any MODE SENSE commands would return 520 in the BLOCK LENGTH field). To determine the block length at which the logical unit is currently formatted, the application client shall use the READ CAPACITY command (see 5.11) rather than the MODE SELECT command.

6.3.2.3 Long LBA mode parameter block descriptor

Table 106 defines the block descriptor for direct-access block devices used with the MODE SELECT (10) command and MODE SENSE (10) command when the **LONGLBA** bit is set to one in the mode parameter header (see SPC-4).

Table 106 — Long LBA mode parameter block descriptor

Byte\Bit	7	6	5	4	3	2	1	0
0	(MSB)							
	NUMBER OF BLOCKS							
7	(LSB)							
8	Reserved							
11								
12	(MSB)							
	BLOCK LENGTH							
15	(LSB)							

A device server shall respond to a MODE SENSE command (see SPC-4) by reporting the number of blocks specified in the **NUMBER OF BLOCKS** field sent in the last MODE SELECT command that contained a mode parameter block descriptor. If no MODE SELECT command with a mode parameter block descriptor has been received then the current number of blocks shall be returned. To determine the number of blocks at which the logical unit is currently formatted, the application client shall use the **READ CAPACITY** command (see 5.11) rather than the MODE SELECT command.

On a MODE SENSE command, the device server may return a value of zero indicating that it does not report the number of blocks in the long LBA mode parameter block descriptor.

If the logical unit does not support changing its capacity by changing the **NUMBER OF BLOCKS** field using the MODE SELECT command (see SPC-4), the value in the **NUMBER OF BLOCKS** field is ignored. If the device supports changing its capacity by changing the **NUMBER OF BLOCKS** field, then the **NUMBER OF BLOCKS** field is interpreted as follows:

- a) If the **NUMBER OF BLOCKS** field is set to zero, the logical unit shall retain its current capacity if the block length has not changed. If the **NUMBER OF BLOCKS** field is set to zero and the content of the **BLOCK LENGTH** field (i.e., new block length) is different than the current block length, the logical unit shall be set to its maximum capacity when the new block length takes effect (i.e., after a successful **FORMAT UNIT** command);
- b) If the **NUMBER OF BLOCKS** field is greater than zero and less than or equal to its maximum capacity, the logical unit shall be set to that number of blocks. If the content of the **BLOCK LENGTH** field is the same as the current block length, the logical unit shall not become format corrupt. This capacity setting shall be retained through power cycles, hard resets, logical unit resets, and I_T nexus losses. If the content of the **BLOCK LENGTH** field is the same as the current block length this capacity setting shall take effect on successful completion of the MODE SELECT command. If the content of the **BLOCK LENGTH** field (i.e., new block length) is different than the current block length this capacity setting shall take effect when the new block length takes effect (i.e., after a successful **FORMAT UNIT** command);
- c) If the **NUMBER OF BLOCKS** field is set to a value greater than the maximum capacity of the device and less than FFFFFFFF FFFFFFFFh, then the device server shall terminate the MODE SELECT command with **CHECK CONDITION** status with the sense key set to **ILLEGAL REQUEST** and the additional sense code set to **INVALID FIELD IN PARAMETER LIST**. The logical unit shall retain its previous block descriptor settings; or
- d) If the **NUMBER OF BLOCKS** field is set to FFFFFFFF FFFFFFFFh, the logical unit shall be set to its maximum capacity. If the content of the **BLOCK LENGTH** field is the same as the current block length, the logical unit shall not become format corrupt. This capacity setting shall be retained through power cycles, hard resets, logical unit resets, and I_T nexus losses. If the content of the **BLOCK LENGTH** field is the same as the current block length this capacity setting shall take effect on successful completion of the MODE SELECT command. If the content of the **BLOCK LENGTH** field (i.e., new block length) is

different than the current block length this capacity setting shall take effect when the new block length takes effect (i.e., after a successful FORMAT UNIT command).

The BLOCK LENGTH field specifies the length in bytes of each logical block. No change shall be made to any logical blocks on the medium until a format operation (see 5.2) is initiated by an application client.

A device server shall respond to a MODE SENSE command (see SPC-4) by reporting the length of the logical blocks as specified in the BLOCK LENGTH field sent in the last MODE SELECT command that contained a mode parameter block descriptor. If no MODE SELECT command with a block descriptor has been received then the current block length shall be returned (e.g., if the block length is 512 bytes and a MODE SELECT command occurs with the BLOCK LENGTH field set to 520 bytes, any MODE SENSE commands would return 520 in the BLOCK LENGTH field). To determine the block length at which the logical unit is currently formatted, the application client shall use the READ CAPACITY command (see 5.11) rather than the MODE SELECT command.

6.3.3 Background Control mode page

The Background Control mode page (see table 107) is a subpage of the Informational Exception Control mode page (see SPC-4) and provides controls over background operations. The mode page policy (see SPC-4) for this subpage shall be shared.

Table 107 — Background Control mode page

Byte/Bit	7	6	5	4	3	2	1	0
0	PS	SPF(1b)	PAGE CODE (1Ch)					
1	SUBPAGE CODE (01h)							
2	(MSB)	PAGE LENGTH (000Ch)						(LSB)
3								
4	Reserved							EN_BMS
5	Reserved							EN_PS
6	(MSB)	BMS INTERVAL TIME						(LSB)
7								
8	(MSB)	PRE-SCAN TIMEOUT VALUE						(LSB)
9								
10	Reserved							
15	Reserved							

An enable background medium scan (EN_BMS) bit set to zero specifies that background medium scan is disabled. An EN_BMS bit set to one specifies that background medium scan operations are enabled. If the EN_PS bit is also set to one then a background medium scan operation shall not start until after the pre-scan operation is halted or completed. The BMS interval time shall occur before a background medium scan operation is started. If a background medium scan is in progress when the EN_BMS bit is changed from one to zero, then the medium scan shall be suspended until the EN_BMS bit is set to one, at which time the medium scan shall resume from the suspended location.

An enable pre-scan (EN_PS) bit set to zero specifies that pre-scan is disabled. If a pre-scan operation is in progress when EN_PS is changed from a one to a zero then pre-scan is halted. An EN_PS bit set to one specifies that a pre-scan operation is started after the next power on cycle. Once this pre-scan has completed, another pre-scan shall not occur unless the EN_PS bit is set to zero, then set to one, and another power on cycle occurs.

The BMS INTERVAL TIME field specifies the minimum time, in hours, between the start of one pre-scan or background medium scan operation and the start of the next background medium scan operation. If the

current background medium scan operation takes longer than the value specified in the BMS INTERVAL TIME field, then the current background medium scan or pre-scan continues until completion and the next background medium scan operation starts on completion of the current background medium scan or pre-scan.

The PRE-SCAN TIMEOUT VALUE field specifies the maximum time, in hours, for a pre-scan operation to complete. If the pre-scan operation does not complete within the specified time then it is halted. A value of zero specifies an unlimited timeout value.

6.3.4 Caching mode page

The Caching mode page (see table 108) defines the parameters that affect the use of the cache.

Table 108 — Caching mode page

Byte\Bit	7	6	5	4	3	2	1	0
0	PS	Reserved	PAGE CODE (08h)					
1	PAGE LENGTH (12h)							
2	IC	ABPF	CAP	DISC	SIZE	WCE	MF	RCD
3	DEMAND READ RETENTION PRIORITY				WRITE RETENTION PRIORITY			
4	(MSB)	DISABLE PRE-FETCH TRANSFER LENGTH						(LSB)
5								
6	(MSB)	MINIMUM PRE-FETCH						(LSB)
7								
8	(MSB)	MAXIMUM PRE-FETCH						(LSB)
9								
10	(MSB)	MAXIMUM PRE-FETCH CEILING						(LSB)
11								
12	FSW	LBCSS	DRA	Vendor specific		Reserved		NV_DIS
13	NUMBER OF CACHE SEGMENTS							
14	(MSB)	CACHE SEGMENT SIZE						(LSB)
15								
16	Reserved							
17								
19	Obsolete							

The parameters savable (PS) bit is only used with the MODE SENSE command. This bit is reserved with the MODE SELECT command. A PS bit set to one indicates that the device server is capable of saving the mode page in a non-volatile vendor-specific location. If the PS is set to one in MODE SENSE data then the mode page shall be savable by issuing a MODE SELECT command with the SP bit set to one.

An initiator control (IC) enable bit set to one specifies that the device server use one of the following fields to control the caching algorithm rather than the device server's own adaptive algorithm:

- a) the NUMBER OF CACHE SEGMENTS field, if the SIZE bit is set to one; or
- b) the CACHE SEGMENT SIZE field, if the SIZE bit is set to zero.

An abort pre-fetch (ABPF) bit set to one, with the DRA bit set to zero, specifies that the device server abort a pre-fetch upon receipt of a new command. An ABPF bit set to one takes precedence over the value specified in the MINIMUM PRE-FETCH field. An ABPF bit set to zero, with the DRA bit set to zero, specifies that the termination of any active pre-fetch is dependent upon Caching mode page bytes 4 through 11 and is vendor-specific.

A caching analysis permitted (CAP) bit set to one specifies that the device server perform caching analysis during subsequent operations. A CAP bit set to zero specifies that caching analysis be disabled (e.g., to reduce overhead time or to prevent nonpertinent operations from impacting tuning values).

A discontinuity (DISC) bit set to one specifies that the device server continue the pre-fetch across time discontinuities (e.g., across cylinders) up to the limits of the buffer, or segment, space available for the pre-fetch. A DISC bit set to zero specifies that pre-fetches be truncated or wrapped at time discontinuities.

A size enable (SIZE) bit set to one specifies that the CACHE SEGMENT SIZE field be used to control caching segmentation. A SIZE bit set to zero specifies that the NUMBER OF CACHE SEGMENTS field be used to control caching segmentation. Simultaneous use of both the number of segments and the segment size is vendor-specific.

A writeback cache enable (WCE) bit set to zero specifies that the device server shall return GOOD status for a WRITE command only after successfully writing all of the data to the medium. A WCE bit set to one specifies that the device server may return GOOD status for a WRITE command after successfully receiving the data and prior to having successfully written it to the medium.

A multiplication factor (MF) bit set to zero specifies that the device server shall interpret the MINIMUM PRE-FETCH field and the MAXIMUM PRE-FETCH field in terms of the number of logical blocks for each of the respective types of pre-fetch. An MF bit set to one specifies that the device server shall interpret the MINIMUM PRE-FETCH field and the MAXIMUM PRE-FETCH field to be specified in terms of a scalar number that, when multiplied by the number of logical blocks to be transferred for the current command, yields the number of logical blocks for each of the respective types of pre-fetch.

A read cache disable (RCD) bit set to zero specifies that the device server may return data requested by a READ command by accessing either the cache or medium. A RCD bit set to one specifies that the device server shall transfer all of the data requested by a READ command from the medium (i.e., data shall not be transferred from the cache).

The DEMAND READ RETENTION PRIORITY field (see table 109) specifies the retention priority the device server should assign for data read into the cache that has also been transferred to the data-in buffer.

Table 109 — DEMAND READ RETENTION PRIORITY field

Code	Description
0h	The device server should not distinguish between retaining the indicated data and data placed into the cache by other means (e.g., pre-fetch).
1h	The device server should replace data put into the cache via a READ command sooner (i.e., read data has lower priority) than data placed into the cache by other means (e.g., pre-fetch).
2h - Eh	Reserved
Fh	The device server should not replace data put into the cache via a READ command if there is other data in the cache that was placed into the cache by other means (e.g., pre-fetch) and the data in the cache may be replaced.

The WRITE RETENTION PRIORITY field (see table 110) specifies the retention priority the device server should assign for data written into the cache that has also been transferred from the cache to the medium.

Table 110 — WRITE RETENTION PRIORITY field

Code	Description
0h	The device server should not distinguish between retaining the indicated data and data placed into the cache by other means (e.g., pre-fetch).
1h	The device server should replace data put into the cache during a WRITE command or a WRITE AND VERIFY command sooner (i.e., has lower priority) than data placed into the cache by other means (e.g., pre-fetch).
2h - Eh	Reserved
Fh	The device server should not replace data put into the cache during a WRITE command or a WRITE AND VERIFY command if there is other data in the cache that was placed into the cache by other means (e.g., pre-fetch) and the data in the cache may be replaced.

An anticipatory pre-fetch occurs when data is placed in the cache that has not been requested. This may happen in conjunction with the reading of data that has been requested. The DISABLE PRE-FETCH TRANSFER LENGTH field, the MINIMUM PRE-FETCH field, the MAXIMUM PRE-FETCH field, and the MAXIMUM PRE-FETCH CEILING field give an indication to the device server how it should manage the cache based on the most recent READ command. An anticipatory pre-fetch may occur based on other information. These fields are only recommendations to the device server and should not cause a CHECK CONDITION to occur if the device server is not able to satisfy the request.

The DISABLE PRE-FETCH TRANSFER LENGTH field specifies the selective disabling of anticipatory pre-fetch on long transfer lengths. The value in this field is compared to the transfer length requested by a READ command. If the transfer length is greater than the disable pre-fetch transfer length, then an anticipatory pre-fetch is not done for the command. Otherwise the device server should attempt an anticipatory pre-fetch. If the DISABLE PRE-FETCH TRANSFER LENGTH field is set to zero, then all anticipatory pre-fetching is disabled for any request for data, including those with a transfer length of zero.

The MINIMUM PRE-FETCH field specifies the number of blocks to pre-fetch regardless of the delays it might cause in processing subsequent commands. The field contains either:

- a) a number of blocks, if the MF bit is set to zero; or
- b) a scalar multiplier of the value in the TRANSFER LENGTH field, if the MF bit is set to one.

The pre-fetching operation begins at the logical block after the last logical block of a READ command. Pre-fetching shall always halt when it reaches the last logical block on the medium. Errors that occur during the pre-fetching operation shall not be reported to the application client unless the device server is unable to process subsequent commands correctly as a result of the error. In this case the error may be reported either as an error for that subsequent command, or as a deferred error, at the discretion of the device server and according to the rules for reporting deferred errors (see SPC-4).

If the pre-fetch has read more than the amount of data specified by the MINIMUM PRE-FETCH field, then pre-fetching should be terminated whenever another command enters the enabled state (see SAM-4). This consideration is ignored when the MINIMUM PRE-FETCH field value is equal to the MAXIMUM PRE-FETCH field value.

The MAXIMUM PRE-FETCH field specifies the number of blocks to pre-fetch if the pre-fetch does not delay processing of subsequent commands. The field contains either:

- a) a number of blocks, if the MF bit is set to zero; or
- b) a scalar multiplier of the value in the TRANSFER LENGTH field, if the MF bit is set to one.

The MAXIMUM PRE-FETCH field contains the maximum amount of data to pre-fetch as a result of one READ command. It is used in conjunction with the DISABLE PRE-FETCH TRANSFER LENGTH field and MAXIMUM PRE-FETCH CEILING field to trade off pre-fetching new data with displacing old data already stored in the cache.

The MAXIMUM PRE-FETCH CEILING field specifies an upper limit on the number of logical blocks computed as the maximum pre-fetch. If this number of blocks is greater than the value in the MAXIMUM PRE-FETCH field, then the number of logical blocks to pre-fetch shall be truncated to the value stored in the MAXIMUM PRE-FETCH CEILING field.

NOTE 24 - If the MF bit is set to one the MAXIMUM PRE-FETCH CEILING field is useful in limiting the amount of data to be pre-fetched.

A force sequential write (FSW) bit set to one specifies that, for commands writing to more than one logical block, the device server shall write the logical blocks to the medium in ascending sequential order. An FSW bit set to zero specifies that the device server may reorder the sequence of writing logical blocks (e.g., in order to achieve faster command completion).

A logical block cache segment size (LBCSS) bit set to one specifies that the CACHE SEGMENT SIZE field units shall be interpreted as logical blocks. An LBCSS bit set to zero specifies that the CACHE SEGMENT SIZE field units shall be interpreted as bytes. The LBCSS shall not impact the units of other fields.

A disable read-ahead (DRA) bit set to one specifies that the device server shall not read into the pre-fetch buffer any logical blocks beyond the addressed logical block(s). A DRA bit set to zero specifies that the device server may continue to read logical blocks into the pre-fetch buffer beyond the addressed logical block(s).

The NUMBER OF CACHE SEGMENTS field specifies the number of segments into which the device server shall divide the cache.

The CACHE SEGMENT SIZE field specifies the segment size in bytes if the LBCSS bit is set to zero or in logical blocks if the LBCSS bit is set to one. The CACHE SEGMENT SIZE field is valid only when the SIZE bit is set to one.

An NV_DIS bit set to one specifies that the device server shall disable a non-volatile cache and indicates that a non-volatile cache is supported but disabled. An NV_DIS bit set to zero specifies that the device server may use a non-volatile cache and indicates that a non-volatile cache may be present and enabled.

6.3.5 Read-Write Error Recovery mode page

The Read-Write Error Recovery mode page (see table 111) specifies the error recovery parameters the device server shall use during any command that performs a read or write operation to the medium (e.g., READ commands, WRITE commands, and WRITE AND VERIFY commands).

Table 111 — Read-Write Error Recovery mode page

Byte\Bit	7	6	5	4	3	2	1	0
0	PS	Reserved	PAGE CODE (01h)					
1	PAGE LENGTH (0Ah)							
2	AWRE	ARRE	TB	RC	Error recovery bits			
					EER	PER	DTE	DCR
3	READ RETRY COUNT							
4	Obsolete							
5	Obsolete							
6	Obsolete							
7	Reserved						Restricted for MMC-4	
8	WRITE RETRY COUNT							
9	Reserved							
10	(MSB)	RECOVERY TIME LIMIT						(LSB)
11								

The parameters savable (PS) bit is only used with the MODE SENSE command. This bit is reserved with the MODE SELECT command. A PS bit set to one indicates that the device server is capable of saving the mode page in a non-volatile vendor-specific location.

An automatic write reallocation enabled (AWRE) bit set to zero specifies that the device server shall not perform automatic reallocation of defective logical blocks during write operations.

An AWRE bit set to one specifies that the device server shall enable automatic reallocation of defective logical blocks during write operations. The automatic reallocation shall be performed only if the device server has the valid data (e.g., original data in a buffer or recovered from the medium). The valid data shall be placed in the reallocated logical block. The device server shall report any failures that occur during the reallocation operation. Error reporting as specified by the error recovery bits (i.e., the EER bit, the PER bit, the DTE bit, and the DCR bit) shall be performed only after completion of the reallocation. See the REASSIGN BLOCKS command (see 5.16) for error procedures.

An automatic read reallocation enabled (ARRE) bit set to zero specifies that the device server shall not perform automatic reallocation of defective logical blocks during read operations.

An ARRE bit set to one specifies that the device server shall enable automatic reallocation of defective logical blocks during read operations. All error recovery actions required by the error recovery bits (i.e., the EER bit, the PER bit, the DTE bit, and the DCR bit) shall be processed. The automatic reallocation shall then be performed only if the device server successfully recovers the data. The recovered data shall be placed in the reallocated logical block. The device server shall report any failures that occur during the reallocation operation. Error reporting as specified by the error recovery bits (i.e., the EER bit, the PER bit, the DTE bit, and the DCR bit) shall be performed only after completion of the reallocation operation. See the REASSIGN BLOCKS command (see 5.16) for error procedures.

A transfer block (TB) bit set to zero specifies that the device server shall not transfer a logical block to the data-in buffer if the logical block is not recovered within the recovery limits specified. A TB bit set to one specifies that the device server shall transfer a logical block to the data-in buffer before returning CHECK CONDITION status if the logical block is not recovered within the recovery limits specified. The data returned in this case is vendor-specific. The TB bit does not affect the action taken for recovered data.

A read continuous (RC) bit set to zero specifies that error recovery operations that cause delays are acceptable during the data transfer. Data shall not be fabricated.

An RC bit set to one specifies the device server shall transfer the entire requested length of data without adding delays to perform error recovery procedures. This implies that the device server may send data that is erroneous or fabricated in order to maintain a continuous flow of data. The device server shall assign priority to the RC bit over conflicting bits within this byte.

NOTE 25 - Fabricated data may be data already in a buffer or any other vendor-specific data. The RC bit may be used in image processing, audio, or video applications.

An enable early recovery (EER) bit set to one specifies that the device server shall use the most expedient form of error recovery first. An EER bit set to zero specifies that the device server shall use an error recovery procedure that minimizes the risk of error mis-detection or mis-correction. This bit only applies to data error recovery and it does not affect positioning retries.

NOTE 26 - An EER bit set to one may imply an increase in the probability of error mis-detection or mis-correction. An EER bit set to zero allows the specified retry limit to be exhausted prior to using error correction codes.

A post error (PER) bit set to one specifies that the device server shall report recovered errors. A PER bit set to zero specifies that the device server shall not report recovered errors, and the device server shall perform error recovery procedures within the limits established by the error recovery parameters.

A data terminate on error (DTE) bit set to one specifies that the device server shall terminate the data-in or data-out buffer transfer upon detection of a recovered error. A DTE bit set to zero specifies that the device server shall not terminate the data-in or data-out buffer transfer upon detection of a recovered error.

A disable correction (DCR) bit set to one specifies that ECC (see 4.4) shall not be used for data error recovery. A DCR bit set to zero allows the use of ECC for data error recovery.

The combinations of the error recovery bits (i.e., the EER bit, the PER bit, the DTE bit, and the DCR bit) are explained in table 112.

Table 112 — Combined error recovery bit descriptions (part 1 of 3)

EER	PER	DTE	DCR	Description
0	0	0	0	<p>The device server shall perform the full number of retries as specified in the READ RETRY COUNT field for read operations, the WRITE RETRY COUNT field for write operations, and the VERIFY RETRY COUNT field (see 6.3.6) for verify operations and shall perform error correction in an attempt to recover the data.</p> <p>The device server shall not report recovered errors. The device server shall terminate a command with CHECK CONDITION status before the transfer count is exhausted only if an unrecoverable error is detected.</p> <p>If an unrecoverable data error occurs during a read operation, the data in the block with the unrecoverable error may or may not be transferred to the data-in buffer depending on the setting of the transfer block (TB) bit.</p>
0	0	0	1	<p>The device server shall perform the full number of retries as specified in the READ RETRY COUNT field for read operations, the WRITE RETRY COUNT field for write operations, and the VERIFY RETRY COUNT field (see 6.3.6) for verify operations but shall not perform error correction in an attempt to recover the data.</p> <p>The device server shall not report recovered errors. The device server shall terminate a command with CHECK CONDITION status before the transfer count is exhausted only if an unrecoverable error is detected.</p> <p>If an unrecoverable data error occurs during a read operation, the data in the block with the unrecoverable error may or may not be transferred to the data-in buffer depending on the setting of the transfer block (TB) bit.</p>
0	0	1	0	Invalid mode. The PER bit shall be set to one if the DTE bit is set to one. ^a
0	0	1	1	Invalid mode. The PER bit shall be set to one if the DTE bit is set to one. ^a
0	1	0	0	<p>The device server shall perform the full number of retries as specified in the READ RETRY COUNT field for read operations, the WRITE RETRY COUNT field for write operations, and the VERIFY RETRY COUNT field (see 6.3.6) for verify operations and shall perform error correction in an attempt to recover the data.</p> <p>The device server shall terminate a command with CHECK CONDITION status before the transfer count is exhausted only if an unrecoverable error is detected.</p> <p>If an unrecoverable data error occurs during a read operation, the data in the block with the unrecoverable error may or may not be transferred to the data-in buffer depending on the setting of the transfer block (TB) bit.</p> <p>The device server shall return CHECK CONDITION status with the sense key set to RECOVERED ERROR at the completion of a command during which any recoverable error occurs. The INFORMATION field in the sense data shall contain the LBA of the last recovered error that occurred during the command.</p>

Table 112 — Combined error recovery bit descriptions (part 2 of 3)

EER	PER	DTE	DCR	Description
0	1	0	1	<p>The device server shall perform the full number of retries as specified in the READ RETRY COUNT field for read operations, the WRITE RETRY COUNT field for write operations, and the VERIFY RETRY COUNT field (see 6.3.6) for verify operations but shall not perform error correction in an attempt to recover the data.</p> <p>The device server shall terminate a command with CHECK CONDITION status before the transfer count is exhausted only if an unrecoverable error is detected.</p> <p>If an unrecoverable data error occurs during a read operation, the data in the block with the unrecoverable error may or may not be transferred to the data-in buffer depending on the setting of the transfer block (TB) bit.</p> <p>The device server shall return CHECK CONDITION status with the sense key set to RECOVERED ERROR at the completion of a command during which any recoverable error occurs. The INFORMATION field in the sense data shall contain the LBA of the last recovered error that occurred during the command.</p>
0	1	1	0	<p>The device server shall perform the full number of retries as specified in the READ RETRY COUNT field for read operations, the WRITE RETRY COUNT field for write operations, and the VERIFY RETRY COUNT field (see 6.3.6) for verify operations and shall perform error correction in an attempt to recover the data.</p> <p>The device server shall terminate a command with CHECK CONDITION status before the transfer count is exhausted if any error, either recoverable or unrecoverable, is detected. The INFORMATION field in the sense data shall contain the LBA of the block in error.</p> <p>If an unrecoverable data error occurs during a read operation, the data in the block with the error may or may not be transferred to the data-in buffer depending on the setting of the transfer block (TB) bit.</p>
0	1	1	1	<p>The device server shall perform the full number of retries as specified in the READ RETRY COUNT field for read operations, the WRITE RETRY COUNT field for write operations, and the VERIFY RETRY COUNT field (see 6.3.6) for verify operations but shall not perform error correction in an attempt to recover the data.</p> <p>The device server shall terminate a command with CHECK CONDITION status before the transfer count is exhausted if any error, either recoverable or unrecoverable, is detected. The INFORMATION field in the sense data shall contain the LBA of the block in error.</p> <p>If an unrecoverable data error occurs during a read operation, the data in the block with the error may or may not be transferred to the data-in buffer depending on the setting of the transfer block (TB) bit.</p>

Table 112 — Combined error recovery bit descriptions (part 3 of 3)

EER	PER	DTE	DCR	Description
1	0	0	0	<p>The device server shall perform the fewest possible number of retries and perform error correction in an attempt to recover the data.</p> <p>The device server shall not report recovered errors. The device server shall terminate a command with CHECK CONDITION status before the transfer count is exhausted only if an unrecoverable error is detected.</p> <p>If an unrecoverable data error occurs during a read operation, the data in the block with the unrecoverable error may or may not be transferred to the data-in buffer depending on the setting of the transfer block (TB) bit.</p>
1	0	0	1	Invalid mode. The DCR bit shall be set to zero if the EER bit is set to one. ^a
1	1	0	0	<p>The device server shall perform the fewest possible number of retries and perform error correction in an attempt to recover the data.</p> <p>The device server shall terminate a command with CHECK CONDITION status before the transfer count is exhausted only if an unrecoverable error is detected.</p> <p>If an unrecoverable data error occurs during a read operation, the data in the block with the unrecoverable error may or may not be transferred to the data-in buffer depending on the setting of the transfer block (TB) bit.</p> <p>The device server shall return CHECK CONDITION status with the sense key set to RECOVERED ERROR at the completion of a command during which any recoverable error occurs. The INFORMATION field in the sense data shall contain the LBA of the last recovered error that occurred during the command.</p>
1	1	0	1	Invalid mode. The DCR bit shall be set to zero if the EER bit is set to one. ^a
1	1	1	0	<p>The device server shall perform the fewest possible number of retries and perform error correction in an attempt to recover the data.</p> <p>The device server shall terminate the command with CHECK CONDITION status before the transfer count is exhausted if any error, either recoverable or unrecoverable, is detected. The INFORMATION field in the sense data shall contain the LBA of the block in error.</p> <p>If an unrecoverable data error occurs during a read operation, the data in the block with the error may or may not be transferred to the data-in buffer depending on the setting of the transfer block (TB) bit.</p>
1	1	1	1	Invalid mode. The DCR bit shall be set to zero if the EER bit is set to one. ^a
^a If an invalid combination of the error recovery bits is sent by the application client the device server shall terminate the MODE SELECT command with CHECK CONDITION status with the sense key set to ILLEGAL REQUEST and the additional sense code set to INVALID FIELD IN PARAMETER LIST.				

The READ RETRY COUNT field specifies the number of times that the device server shall attempt its recovery algorithm during read operations.

The WRITE RETRY COUNT field specifies the number of times that the device server shall attempt its recovery algorithm during write operations.

The RECOVERY TIME LIMIT field specifies in milliseconds the maximum time duration that the device server shall use for data error recovery procedures. The device server may round this value as described in SPC-4. The

limit in this field specifies the maximum error recovery time allowed for any individual logical block. A RECOVERY TIME LIMIT field set to zero specifies that the device server shall use its default value.

When both a retry count and a recovery time limit are specified, the field that specifies the recovery action of least duration shall have priority.

NOTE 27 - To disable all types of correction and retries the application client should set the EER bit to zero, the PER bit to one, the DTE bit to one, the DCR bit to one, the READ RETRY COUNT field to 00h, the WRITE RETRY COUNT field to 00h, and the RECOVERY TIME LIMIT field to 0000h.

6.3.6 Verify Error Recovery mode page

The Verify Error Recovery mode page (see table 113) specifies the error recovery parameters the device server shall use during the VERIFY command and the verify operation of the WRITE AND VERIFY command.

Table 113 — Verify Error Recovery mode page

Byte\Bit	7	6	5	4	3	2	1	0
0	PS	Reserved	PAGE CODE (07h)					
1	PAGE LENGTH (0Ah)							
2	Reserved				Error recovery bits			
					EER	PER	DTE	DCR
3	VERIFY RETRY COUNT							
4	Obsolete							
5	Reserved							
9								
10	(MSB)	VERIFY RECOVERY TIME LIMIT						
11								(LSB)

The parameters savable (PS) bit is only used with the MODE SENSE command. This bit is reserved with the MODE SELECT command. A PS bit set to one indicates that the device server is capable of saving the mode page in a non-volatile vendor-specific location.

The AWRE bit as defined in the Read-Write Error Recovery mode page (see 6.3.5) applies to the WRITE AND VERIFY command. The VERIFY command shall not perform automatic reallocation.

The EER bit, the PER bit, the DTE bit, and the DCR bit (i.e., the error recovery bits) are defined in 6.3.5. The combinations of these bits are defined in table 112 (see 6.3.5).

The VERIFY RETRY COUNT field specifies the number of times that the device server shall attempt its recovery algorithm during a verify operation.

The VERIFY RECOVERY TIME LIMIT field specifies in milliseconds the maximum time duration that the device server shall use error recovery procedures to recover data for an individual logical block. The device server may round this value as described in SPC-4.

When both a retry count and a recovery time limit are specified, the one that requires the least time for data error recovery actions shall have priority.

NOTE 28 - To disable all types of correction and retries the application client should set the EER bit to zero, the PER bit to one, the DTE bit to one, the DCR bit to one, the VERIFY RETRY COUNT field to 00h, and the VERIFY RECOVERY TIME LIMIT field to 0000h.

6.3.7 XOR Control mode page

The XOR Control mode page (see table 114) provides the application client with the means to obtain or modify certain XOR operating parameters of the logical unit.

Table 114 — XOR Control mode page

Byte\Bit	7	6	5	4	3	2	1	0
0	PS	Reserved	PAGE CODE (10h)					
1	PAGE LENGTH (16h)							
2	Reserved						XORDIS	Reserved
3	Reserved							
4	(MSB)	MAXIMUM XOR WRITE SIZE						(LSB)
7								
8	Reserved							
11								
12	Obsolete							
19								
20	Reserved							
21								
22	Obsolete							
23								

The parameters savable (PS) bit is only used with the MODE SENSE command. This bit is reserved with the MODE SELECT command. A PS bit set to one indicates that the device server is capable of saving the mode page in a non-volatile vendor-specific location.

An XOR disable (XORDIS) bit set to zero specifies that the device server shall enable processing of XOR commands (i.e., the XDREAD commands (see 5.38 and 5.39), the XDWRITE commands (see 5.40 and 5.41), the XDWRITEREAD commands (see 5.42 and 5.43), and the XPWRITE commands (see 5.44 and 5.45)). An XORDIS bit set to one shall disable processing of XOR commands. If the XORDIS bit is set to one and an XOR command is received, the device server shall terminate the XOR command with CHECK CONDITION status with the sense key set to ILLEGAL REQUEST and the additional sense code set to INVALID COMMAND OPERATION CODE.

The MAXIMUM XOR WRITE SIZE field specifies the maximum transfer length in blocks that the device server accepts for a single XDWRITE or XPWRITE command.

6.4 Vital product data (VPD) parameters

6.4.1 VPD parameters overview

This subclause defines the VPD pages used only with direct-access block devices. See SPC-4 for VPD pages used with all device types.

The VPD page codes specific to direct-access block devices are defined in table 115.

Table 115 — Direct-access block device VPD page codes

VPD page code	VPD page name	Reference	Support requirements
B0h	Block Limits VPD page	6.4.2	Optional
B1h - BFh	Reserved for this standard		

6.4.2 Block Limits VPD page

The Block Limits VPD page (see table 116) provides the application client with the means to obtain certain operating parameters of the logical unit.

Table 116 — Block Limits VPD page

Byte/Bit	7	6	5	4	3	2	1	0
0	PERIPHERAL QUALIFIER			PERIPHERAL DEVICE TYPE				
1	PAGE CODE (B0h)							
2	Reserved							
3	PAGE LENGTH (0Ch)							
4	Reserved							
5								
6	(MSB)	OPTIMAL TRANSFER LENGTH GRANULARITY						(LSB)
7								
8	(MSB)	MAXIMUM TRANSFER LENGTH						(LSB)
11								
12	(MSB)	OPTIMAL TRANSFER LENGTH						(LSB)
15								

The PERIPHERAL QUALIFIER field and the PERIPHERAL DEVICE TYPE field are defined in SPC-4.

The PAGE CODE field shall be set to B0h.

The PAGE LENGTH field is defined in SPC-4.

The OPTIMAL TRANSFER LENGTH GRANULARITY field indicates the optimal transfer length granularity in blocks for a single PRE-FETCH command, READ command, VERIFY command, WRITE command, WRITE AND VERIFY command, XDREAD command, XDWRITE command, XDWRITEREAD command, or XPWRITE command. Transfers with transfer lengths not equal to a multiple of this value may incur significant delays in processing.

The MAXIMUM TRANSFER LENGTH field indicates the maximum transfer length in blocks that the device server accepts for a single PRE-FETCH command, READ command, VERIFY command, WRITE command, WRITE AND VERIFY command, XDREAD command, XDWRITE command, XDWRITEREAD command, or XPWRITE command. Requests for transfer lengths exceeding this limit result in CHECK CONDITION status with the sense key set to ILLEGAL REQUEST and the additional sense code set to INVALID FIELD IN CDB. A MAXIMUM TRANSFER LENGTH field set to zero indicates that there is no reported limit on the transfer length.

The OPTIMAL TRANSFER LENGTH field indicates the optimal transfer length in blocks for a single PRE-FETCH command, READ command, VERIFY command, WRITE command, WRITE AND VERIFY command,

XDREAD command, XDWRITE command, XDWRITEREAD command, or XPWRITE command. Transfers with transfer lengths exceeding this value may incur significant delays in processing.

Annex A

(informative)

Numeric order codes

A.1 Variable length CDBs

Some commands in table 10 (see 5.1) use the variable length command format defined in SPC-4. These commands use operation code 7Fh and are differentiated by service action codes as described in table A.1.

Table A.1 — Variable length command service action code assignments

Operation code/service action code	Description
7Fh/0000h	Reserved
7Fh/0001h	Reserved
7Fh/0002h	Reserved
7Fh/0003h	XDREAD (32)
7Fh/0004h	XDWRITE (32)
7Fh/0005h	Reserved
7Fh/0006h	XPWRITE (32)
7Fh/0007h	XDWRITEREAD (32)
7Fh/0008h	Reserved
7Fh/0009h	READ (32)
7Fh/000Ah	VERIFY (32)
7Fh/000Bh	WRITE (32)
7Fh/000Ch	WRITE AND VERIFY (32)
7Fh/000Dh	WRITE SAME (32)
7Fh/000Eh - 07FFh	Reserved
7Fh/0800h - FFFFh	See SPC-4

A.2 Service action CDBs

Some commands in table 10 (see 5.1) are implemented as device-type specific service actions for the SERVICE ACTION IN (16) operation code 9Eh (see SPC-4). These commands are differentiated by service action codes as described in table A.2.

Table A.2 — SERVICE ACTION IN (16) service actions

Operation code/service action code	Description
9Eh/00h - 0Fh	Reserved for commands applicable to all device types (see SPC-4)
9Eh/10h	READ CAPACITY (16)
9Eh/11h	READ LONG (16)
9Eh/12h - 1Fh	Reserved

Some commands in table 10 (see 5.1) are implemented as device-type specific service actions for the SERVICE ACTION OUT (16) operation code 9Fh (see SPC-4). These commands are differentiated by service action codes as described in table A.3.

Table A.3 — SERVICE ACTION OUT (16) service actions

Operation code/service action code	Description
9Fh/00h - 0Fh	Reserved for commands applicable to all device types (see SPC-4)
9Fh/10h	Reserved
9Fh/11h	WRITE LONG (16)
9Fh/12h - 1Fh	Reserved

Annex B

(informative)

XOR command examples

B.1 XOR command examples overview

This annex provides XOR command examples in storage array controller supervised configurations.

B.2 Update write operation

Figure B.1 shows a read-modify-write operation supervised by a storage array controller. The example uses a supervising storage array controller, a direct-access block device holding XOR-protected data (i.e., the data disk), and a direct-access block device holding check data (i.e., the parity disk). Three SCSI commands are used: an XDWRITE command, an XDREAD command, and an XPWRITE command. An XDWRITEREAD command may be used in place of any sequence of an XDWRITE command followed by an XDREAD command.

The supervising storage array controller begins by sending XOR-protected data to the data disk using an XDWRITE command.

The data disk reads old XOR-protected data from its medium, performs an XOR operation using the old XOR-protected data and the XOR-protected data from the supervising storage array controller, stores the resulting intermediate XOR data in its buffer memory, and writes the XOR-protected data from the supervising storage array controller to its medium. The supervising storage array controller reads the resulting intermediate XOR data from the buffer memory by sending the data disk an XDREAD command.

The supervising storage array controller makes the resulting intermediate XOR data (i.e., data read with the XDREAD command) available to the parity disk by sending an XPWRITE command. The parity disk performs

an XOR operation using the intermediate XOR data and the XOR data in its buffer memory. The resulting new XOR data is written to the medium.

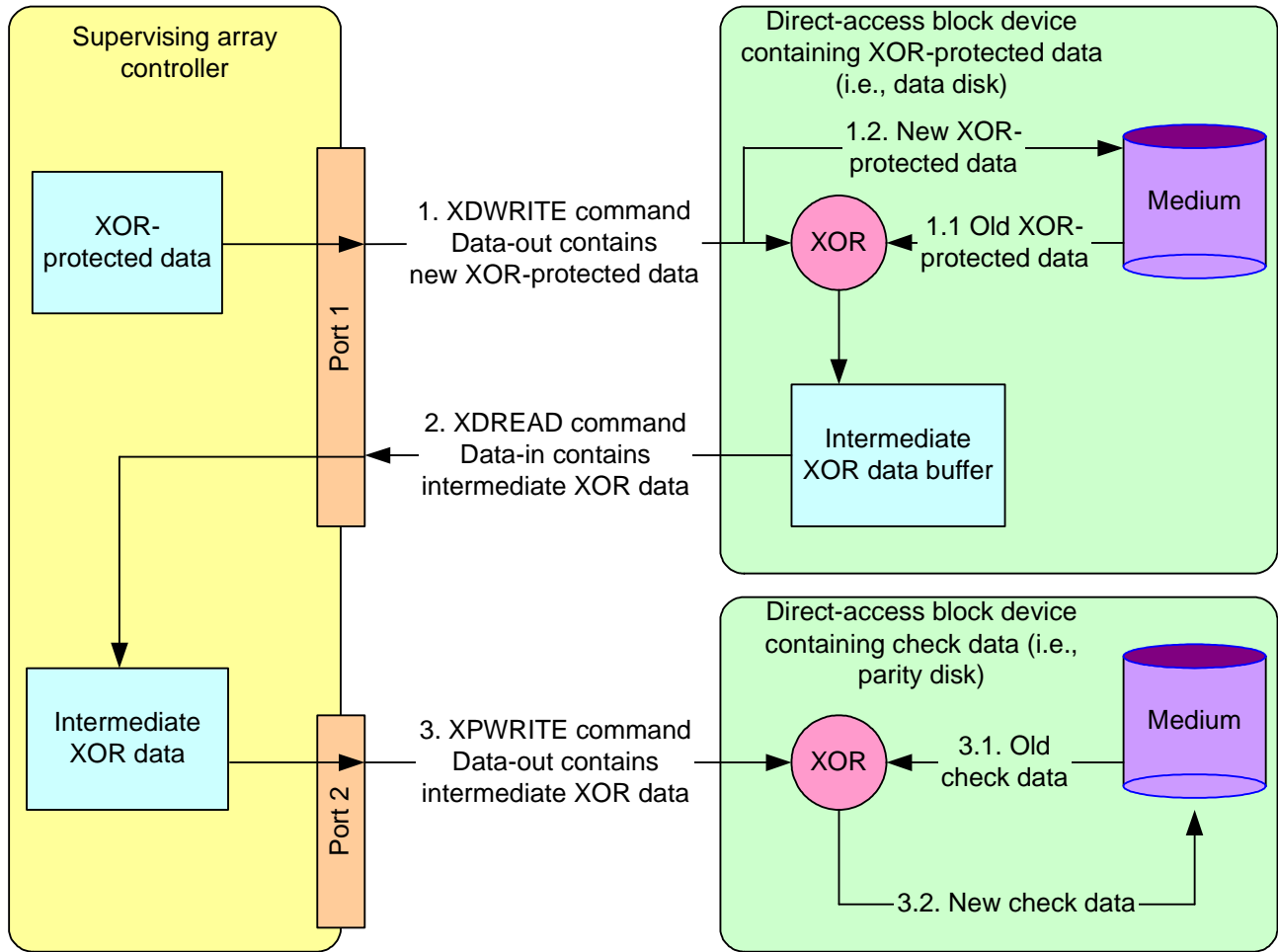

Figure B.1 — Update write operation (storage array controller supervised)

B.3 Regenerate operation

Figure B.2 shows a regenerate operation supervised by a storage array controller. The example uses a supervising storage array controller and three direct-access block devices (i.e., disk 1, disk 2, and disk 3). Three SCSI commands are used: a READ command, an XDWRITE command, and an XDREAD command. An XDWRITEREAD command may be used in place of any sequence of an XDWRITE command followed by an XDREAD command.

The supervising storage array controller begins by issuing a READ command to disk 1. The data received from this command is sent by the supervising storage array controller to disk 2 using an XDWRITE command with the DISABLE WRITE bit set to one. Disk 2 reads data from its medium, performs an XOR operation using that data and the data received from the supervising storage array controller, and stores the resulting intermediate XOR data in its buffer memory. The supervising storage array controller retrieves the intermediate XOR data from the buffer memory by issuing an XDREAD command to disk 2. The supervising storage array controller issues XDWRITE commands and XDREAD commands in the same manner to disk 3.

The resulting data from disk 3 is the regenerated data.

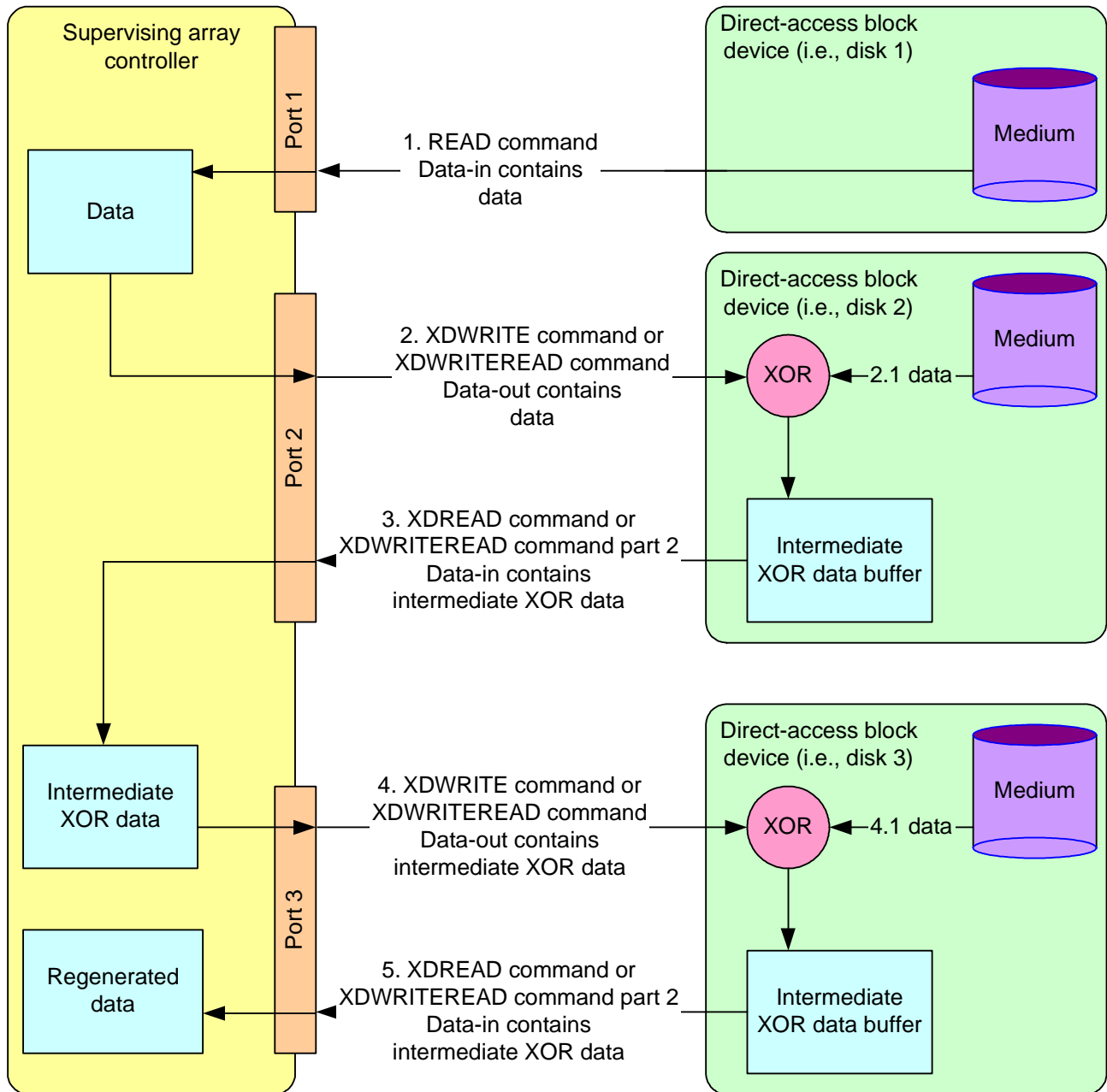

Figure B.2 — Regenerate operation (storage array controller supervised)

B.4 Rebuild operation

Figure B.3 shows a rebuild operation supervised by a storage array controller. The example uses a supervising storage array controller, two direct-access block devices (i.e., disk 1 and disk 2) as the source devices, and one direct-access block device (i.e., disk 3) as the rebuild device. Four SCSI commands are used: a READ command, an XDWRITE command, an XDREAD command, and a WRITE command. An XDWRITEREAD command may be used in place of any sequence of an XDWRITE command followed by an XDREAD command.

The supervising storage array controller begins by issuing a READ command to disk 1. The data received from the READ command is sent by the supervising storage array controller to disk 2 using an XDWRITE command with a DISABLE WRITE bit set to one. Disk 2 reads data from its medium, performs an XOR operation using that data and the data received from the supervising storage array controller, and stores the resulting

intermediate XOR data in its buffer memory. The supervising storage array controller retrieves the intermediate XOR data by sending an XDREAD command to disk 2.

The resulting data from disk 2 is the rebuilt data and is sent to the direct-access block device being rebuilt (i.e., disk 3) using a WRITE command.

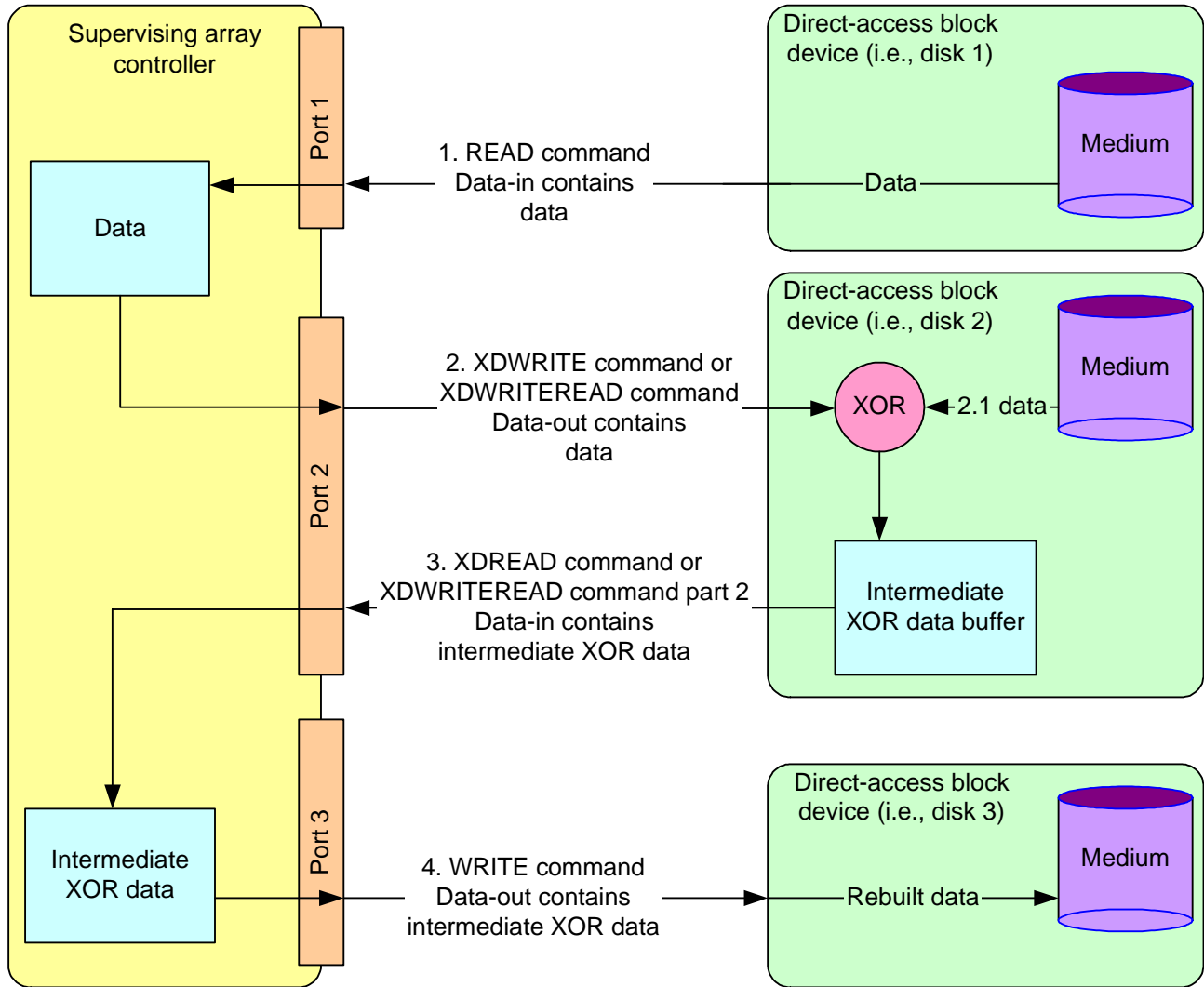

Figure B.3 — Rebuild operation (storage array controller supervised)

Annex C

(informative)

CRC example in C

The following is an example C program that generates the value for the LOGICAL BLOCK GUARD field in protection information (see 4.16).

```
// picrc.cpp : SCSI SBC-2 Protection Information CRC generator
#include "stdafx.h"
#include <stdio.h>
#include <malloc.h>

/* return crc value */
unsigned short calculate_crc(unsigned char *frame, unsigned long length) {
    unsigned short const poly = 0x8BB7L; /* Polynomial */
    unsigned const int poly_length = 16;
    unsigned short crc_gen;
    unsigned short x;
    unsigned int i, j, fb;
    unsigned const int invert = 0; /* 1=seed with 1s and invert the CRC */

    crc_gen = 0x0000;
    crc_gen ^= invert? 0xFFFF: 0x0000; /* seed generator */

    for (i = 0; i < length; i += 2) {
        /* assume little endian */
        x = (frame[i] << 8) | frame[i+1];

        /* serial shift register implementation */
        for (j = 0; j < poly_length; j++) {
            fb = ((x & 0x8000L) == 0x8000L) ^ ((crc_gen & 0x8000L) ==
0x8000L);
            x <<= 1;
            crc_gen <<= 1;
            if (fb)
                crc_gen ^= poly;
        }
    }

    return crc_gen ^ (invert? 0xFFFF: 0x0000); /* invert output */
} /* calculate_crc */

/* function prototype */
unsigned short calculate_crc(unsigned char *, unsigned long);

void main (void) {
    unsigned char *buffer;
    unsigned long buffer_size = 32;
    unsigned short crc;
    unsigned int i;

    /* 32 0x00 */
    buffer = (unsigned char *) malloc (buffer_size);
    for (i = 0; i < buffer_size; i++) {
        buffer[i] = 0x00;
    }
}
```

```
    }
    crc = calculate_crc(buffer, buffer_size);
    printf ("Example CRC all-zeros is %04x\n", crc);
    free (buffer);

    /* 32 0xFF */
    buffer = (unsigned char *) malloc (buffer_size);
    for (i = 0; i < buffer_size; i++) {
        buffer[i] = 0xFF;
    }
    crc = calculate_crc(buffer, buffer_size);
    printf ("Example CRC all-ones is %04x\n", crc);
    free (buffer);

    /* 0x00 incrementing to 0x1F */
    buffer = (unsigned char *) malloc (buffer_size);
    for (i = 0; i < buffer_size; i++) {
        buffer[i] = i;
    }
    crc = calculate_crc(buffer, buffer_size);
    printf ("Example CRC incrementing is %04x\n", crc);
    free (buffer);

    /* 0xFF 0xFF then 30 zeros */
    buffer = (unsigned char *) malloc (buffer_size);
    buffer[0] = 0xff;
    buffer[1] = 0xff;
    for (i = 2; i < buffer_size; i++) {
        buffer[i] = 0x00;
    }
    crc = calculate_crc(buffer, buffer_size);
    printf ("Example CRC FF FF then 30 zeros is %04x\n", crc);
    free (buffer);

    /* 0xFF decrementing to 0xE0 */
    buffer = (unsigned char *) malloc (buffer_size);
    for (i = 0; i < buffer_size; i++) {
        buffer[i] = 0xff - i;
    }
    crc = calculate_crc(buffer, buffer_size);
    printf ("Example CRC FF decrementing to E0 is %04x\n", crc);
    free (buffer);

} /* main */
```