

SFF 8086, 8087, 8088

Molex iPass™ for SAS

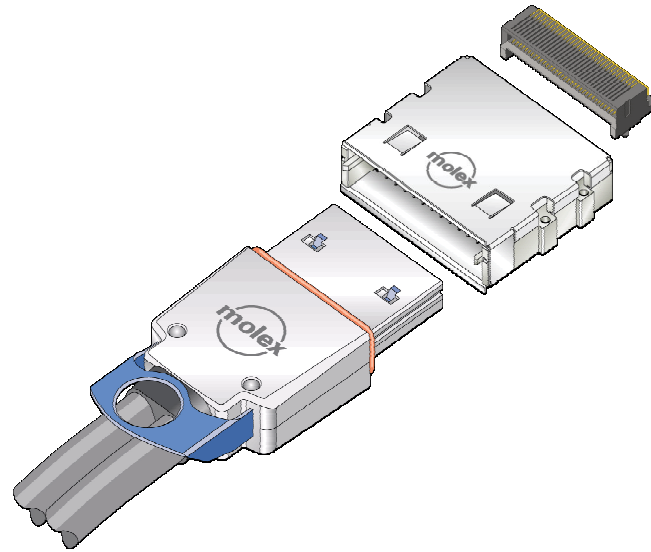

July 12, 2005

Colorado Springs, CO



Connector Products Division: Signal Integrity Group



SAS Reduced Width Connectors



Serial Attached SCSI / SAS – Standards/Products as of 10/04

Typical Application 1 – PCI Host Bus Adapter

(See Molex Website: www.Molex.com/productname/sas/ for Sales Drawings for these products)

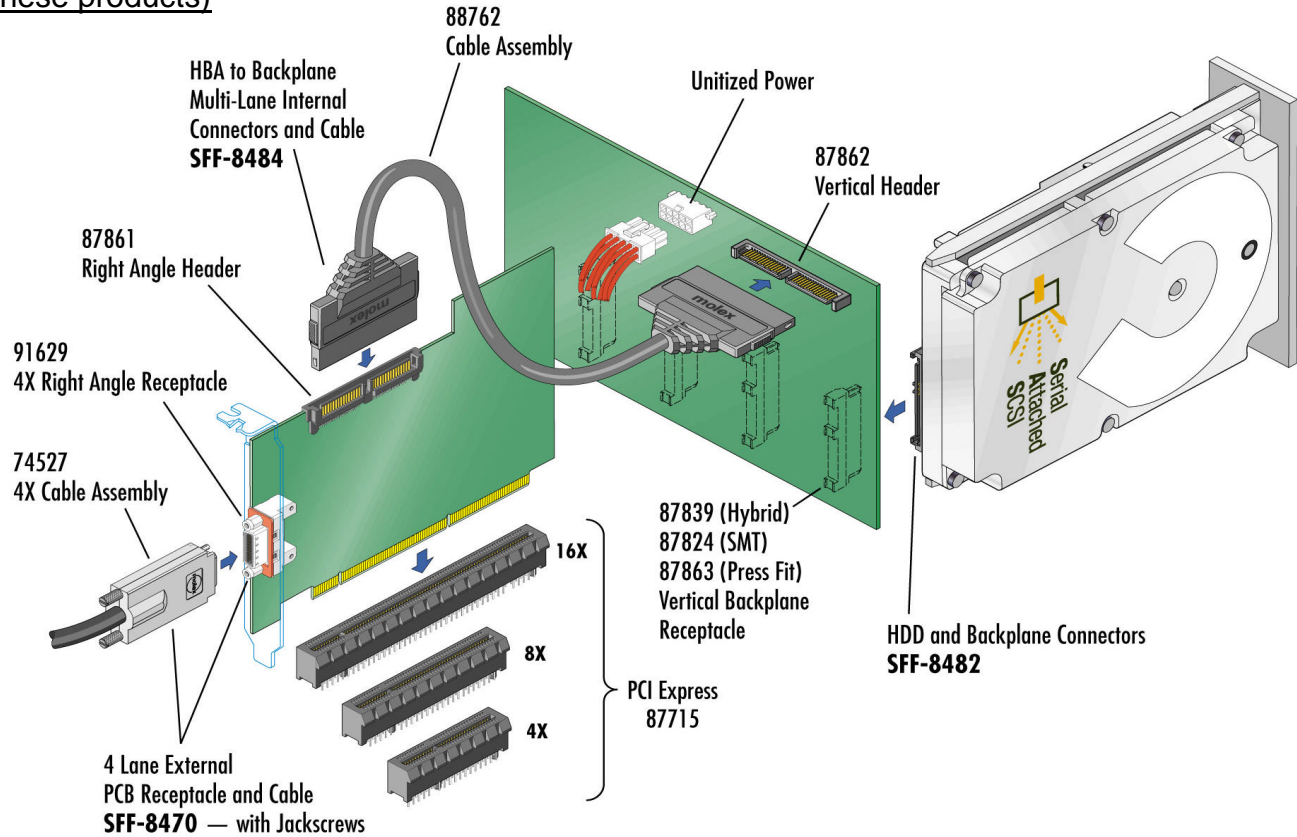

SAS_01e_5F



Connector Products Division: Signal Integrity Group



SAS Reduced Width Connectors



Serial Attached SCSI / SAS – Standards/Products as of 10/04 Typical Application 2 – PCI Redundant Adapters & Raid Controllers

(See Molex Website: www.Molex.com/productname/sas/ for Sales Drawings for these products)

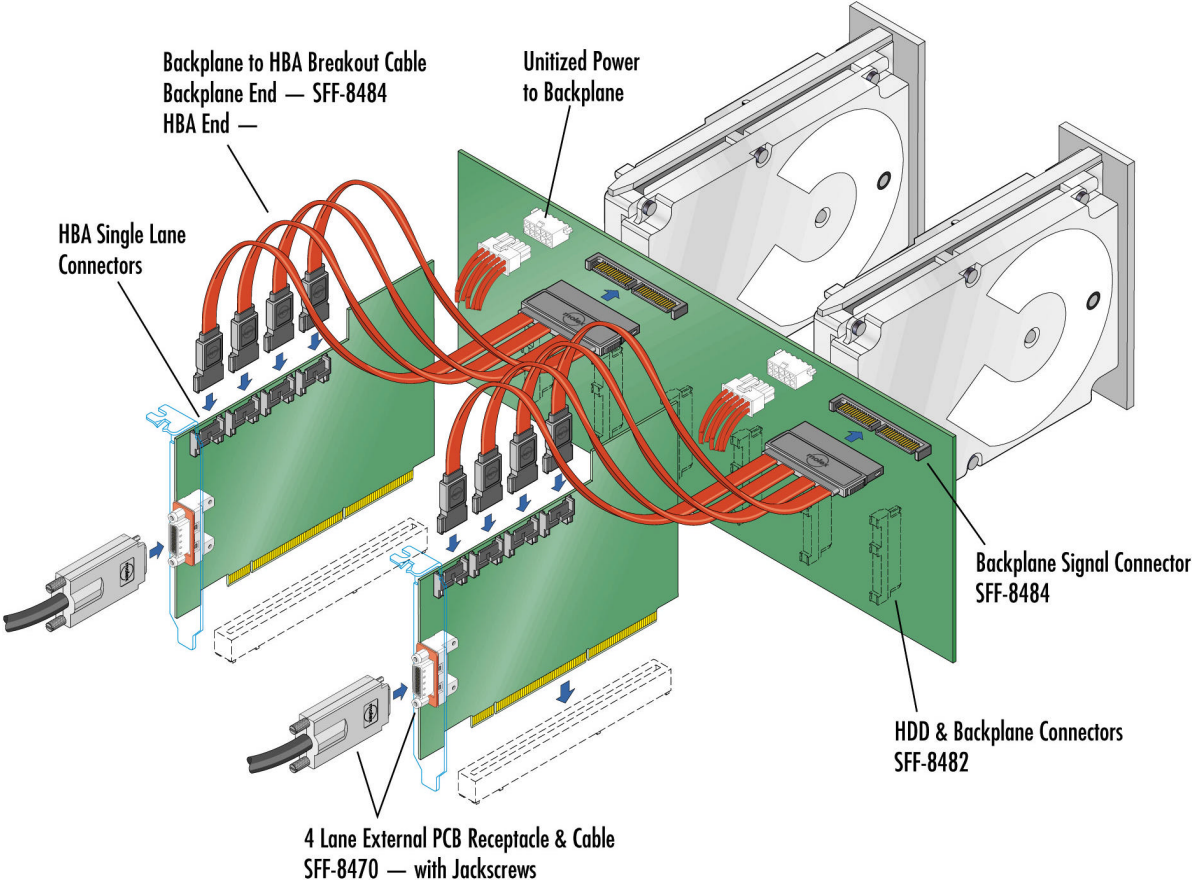

SAS Reduced Width Connectors



The problem with the current products & standards:

The Physical Sizes of the 4x Internal & 4x External Connectors

-Internal requirements for 8x, 16x ports on a PCI card – SFF-8484 only (1) 4x fits

-External requirements for (4) 4x ports on a PCI Card – SFF-8470 only (2) 4x fit

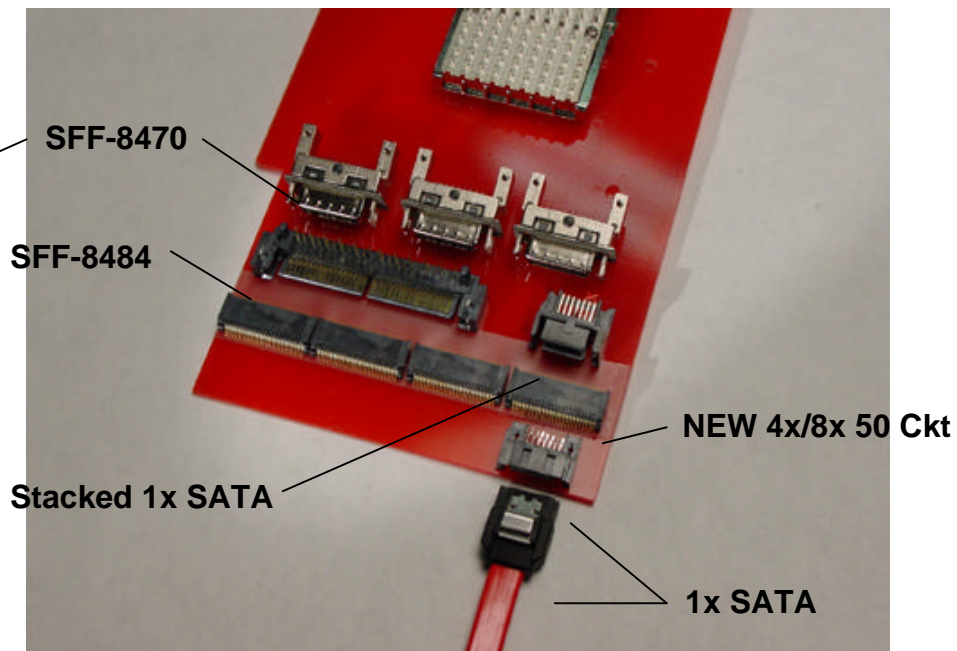
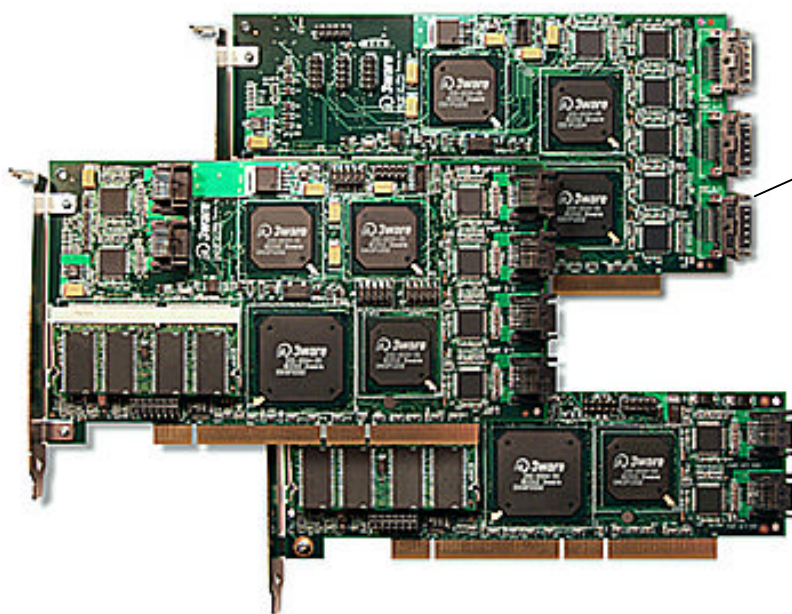

SAS Reduced Width Connectors



The Solution:

-A single surface mount connector can now be used for both internal and external apps
- the connector is rated at 10G (per the XFP MSA Spec)

-Enables (4) 4x internal ports

-Enables (4) 4x external ports

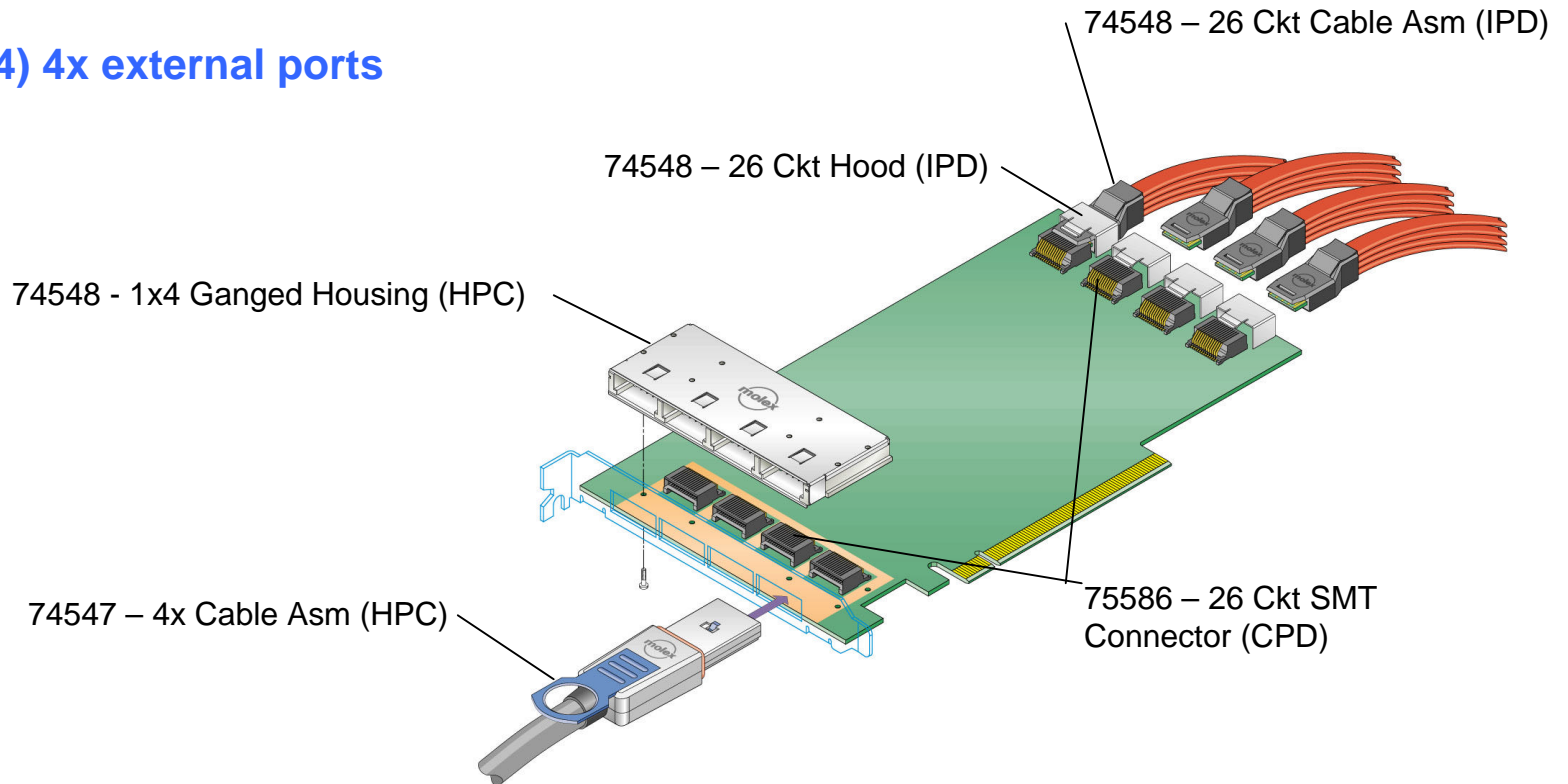

SAS Reduced Width Connectors



The Solution:

-A single surface mount connector can now be used for both internal and external apps
- the connector is rated at 10G (per the XFP MSA Spec)

-Vertical iPass™ (Internal)

-Right Angle iPass™ (Internal)

-Circuit Sizes: 26,36,50,68

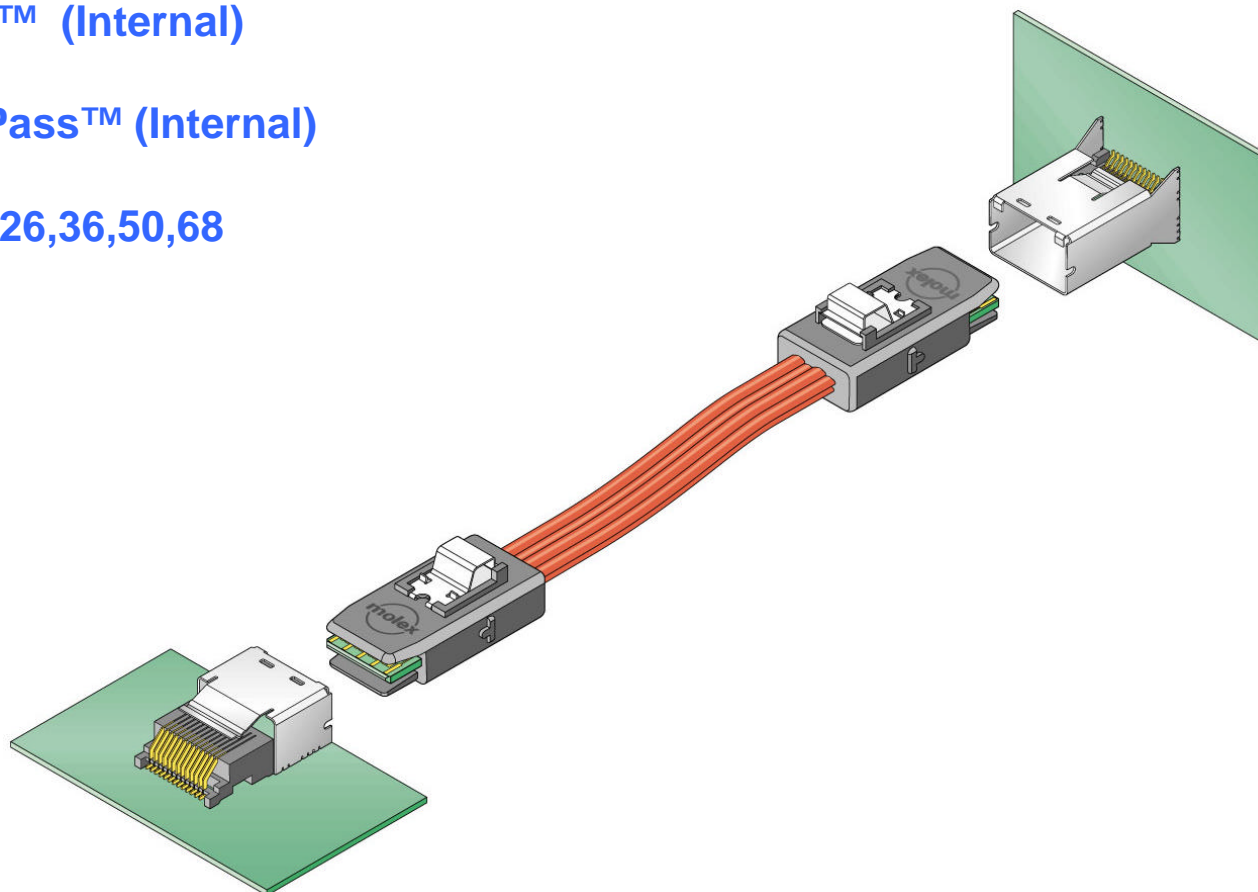

SAS Reduced Width Connectors



New Internal Connectors & Cable
SFF- 8087& T10/04-320r0 SAS 1.1

New External Connectors & Cable
SFF- 8088 & T10/04-321r0 SAS 1.1

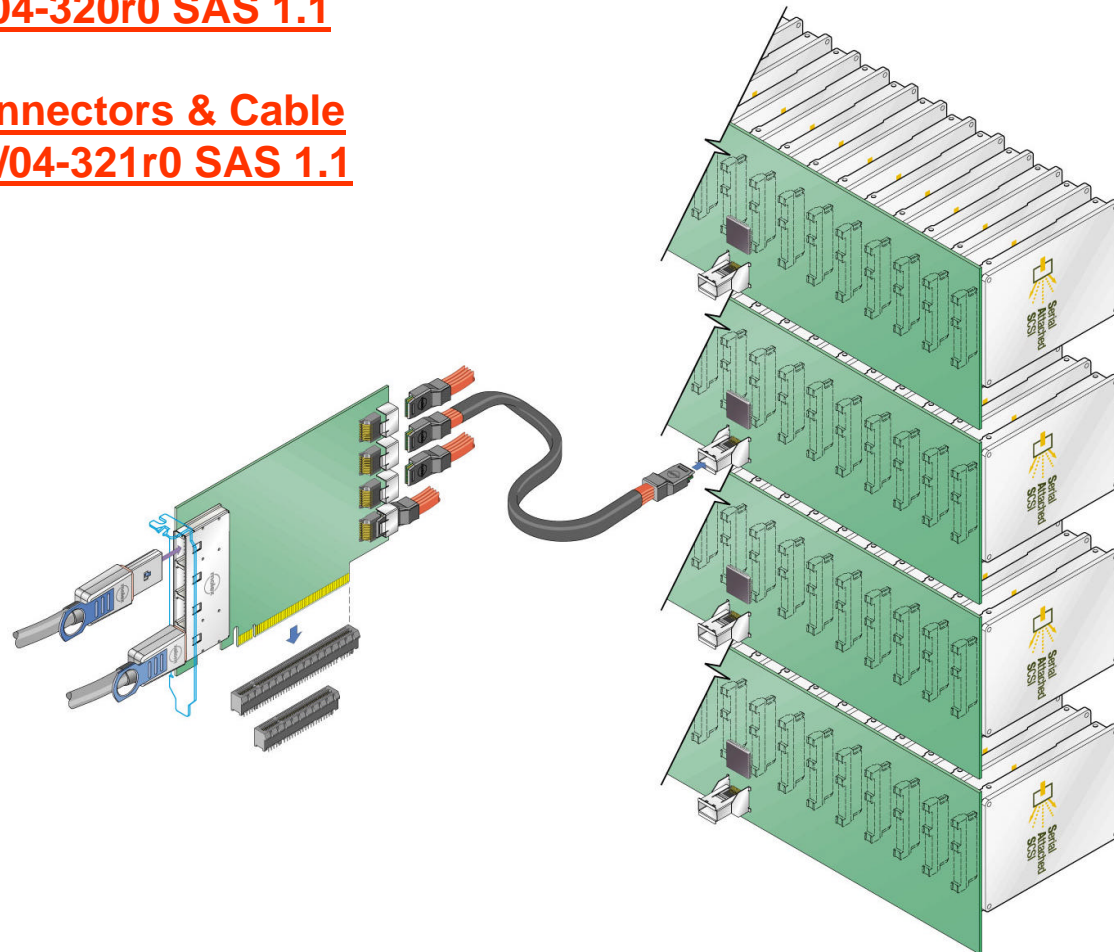

Connector Products Division: Signal Integrity Group



Summary

- ❖ Reduced width design allows (4) ports to be used on a standard PCI bracket vs (3) for the 8470.
- ❖ Cage and cable to faceplate gasketing provide enhanced EMI suppression.
- ❖ Reduced backshell/cable protrusion from the faceplate – 37mm vs 49mm for the 8470.
- ❖ Higher bandwidth – connector testing beyond Gen II signaling up to 10 Gb/s.

Molex iPASS™

■ Vertical and Right-Angle Connector Electrical Testing

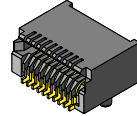

- Tested to (and beyond) XFP MSA 10G specifications
- Impedance, Insertion loss & Crosstalk (isolation) data shown
- Data collected using Agilent 8364B PNA, 4421B port expander, PLTS software, connector test vehicles

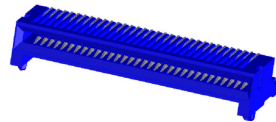

Molex iPASS™

■ Vertical and Right-Angle Connector Electrical Testing

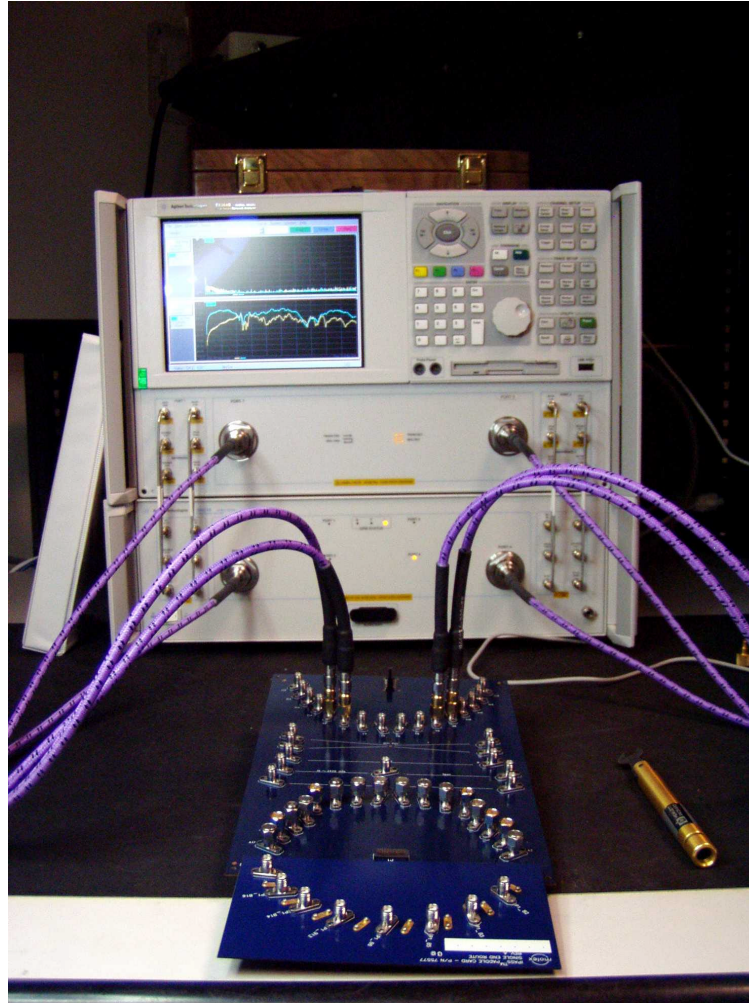

Connector Products Division: Signal Integrity Group



Molex iPASS™

■ Vertical and Right-Angle Connector Electrical Testing

- TRL Calibration structures used, incorporating lines from 10 MHz to 20 GHz coverage
- Calibration reference plane assigned 5 mm from connector SMT attach and edge-card contact

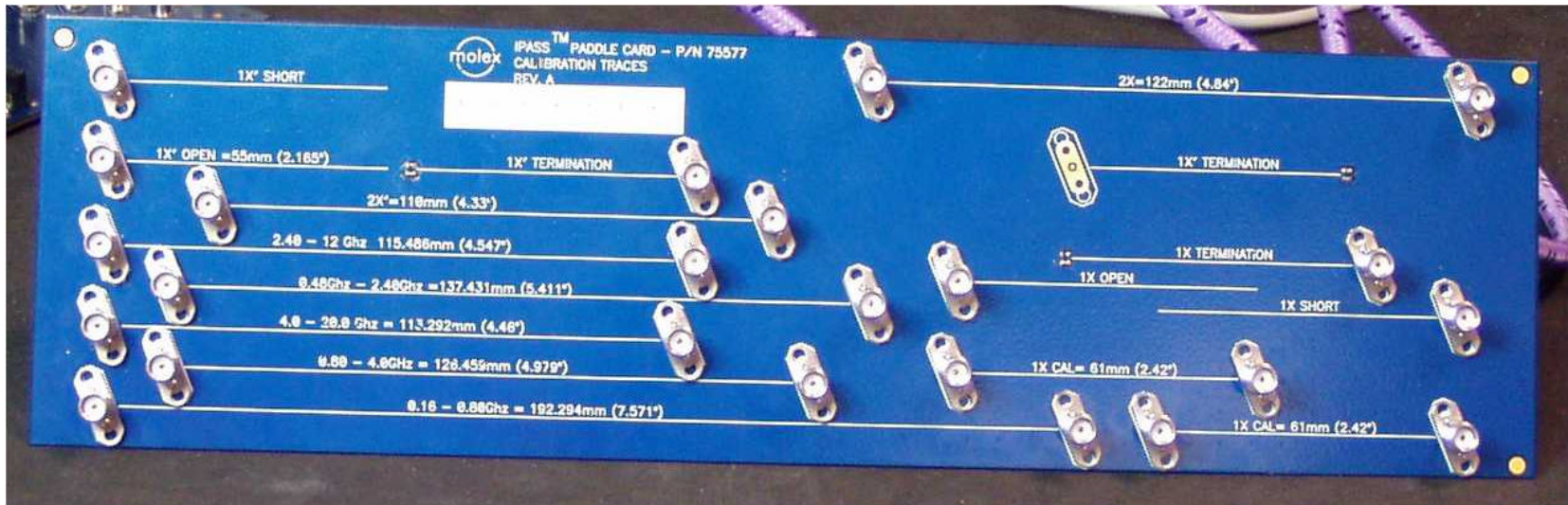

Molex iPASS™

■ Vertical Connector Impedance

- Beyond Gen2 (10 Gb/s)
- Provides 100 +/- 10ohms Performance @ 36ps (10-90%)

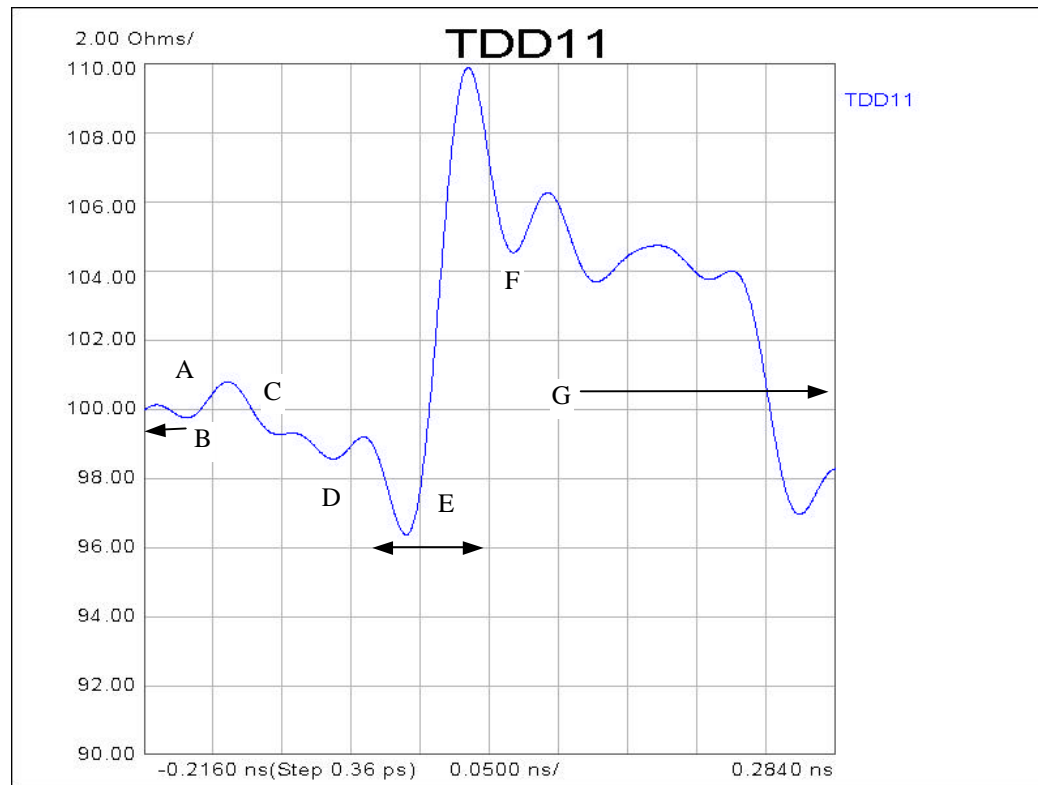

Feature Key:
A - Motherboard
B - Thru hole via
C - Microstrip
D - SMT pad
E - Connector
F - Contact interface
G - Paddle card



Molex iPASS™

■ Vertical Connector Insertion Loss

- 3 dB threshold > 12 GHz
- XFP 10Gb/s, specification (up to 15GHz shown on b13b14 pair)

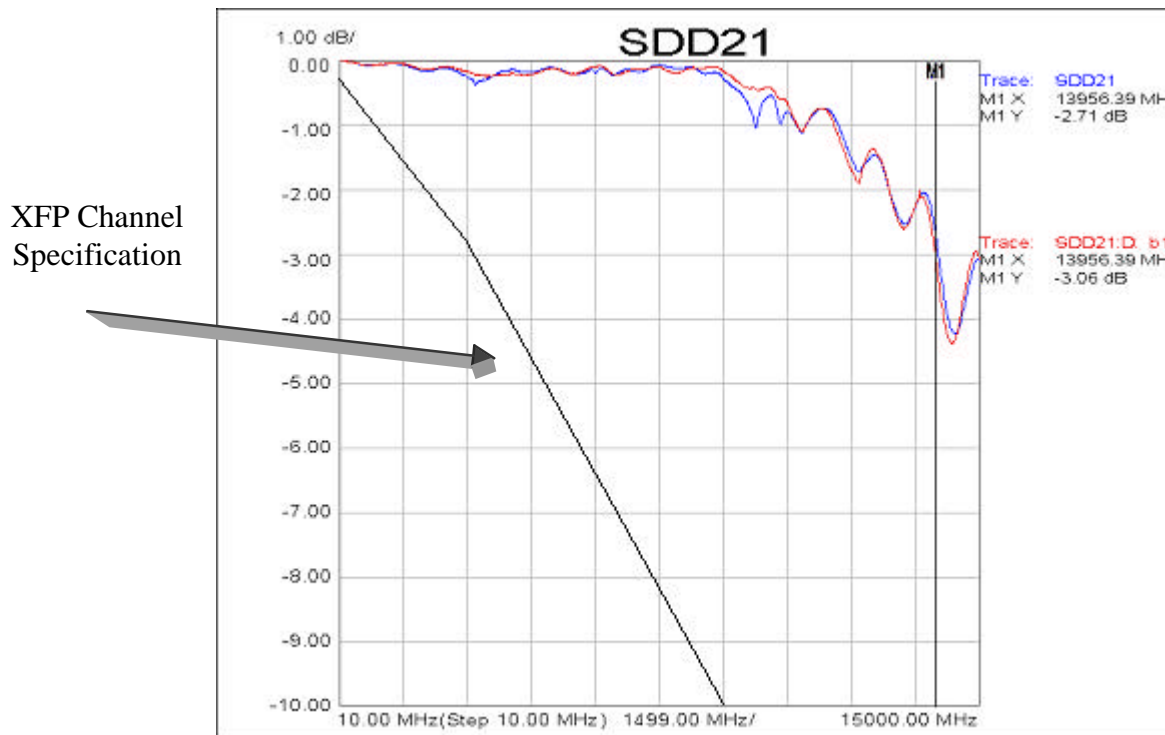

■ Vertical Connector Near-End Isolation

- Frequency-Domain Isolation, nearest-neighbor aggressor
- Swept to 15 GHz
- 26 dB threshold > 12 GHz

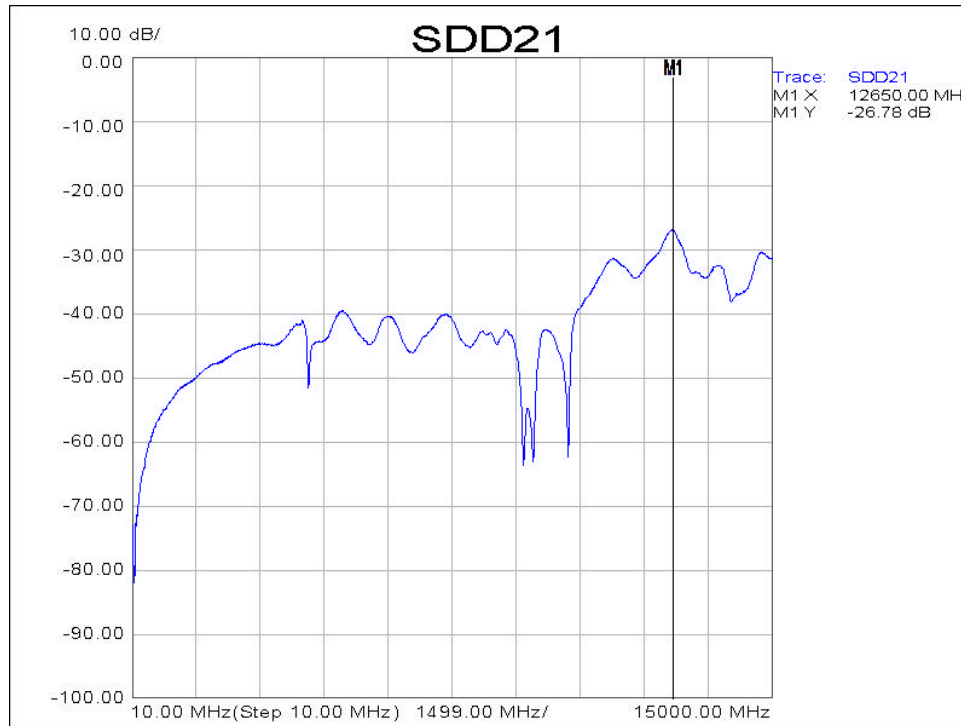

■ Right-Angle Connector Impedance

- Beyond Gen2 (10 Gb/s)
- Long Row Provides 100 +/- 10ohms Performance @ 36ps (10-90%)

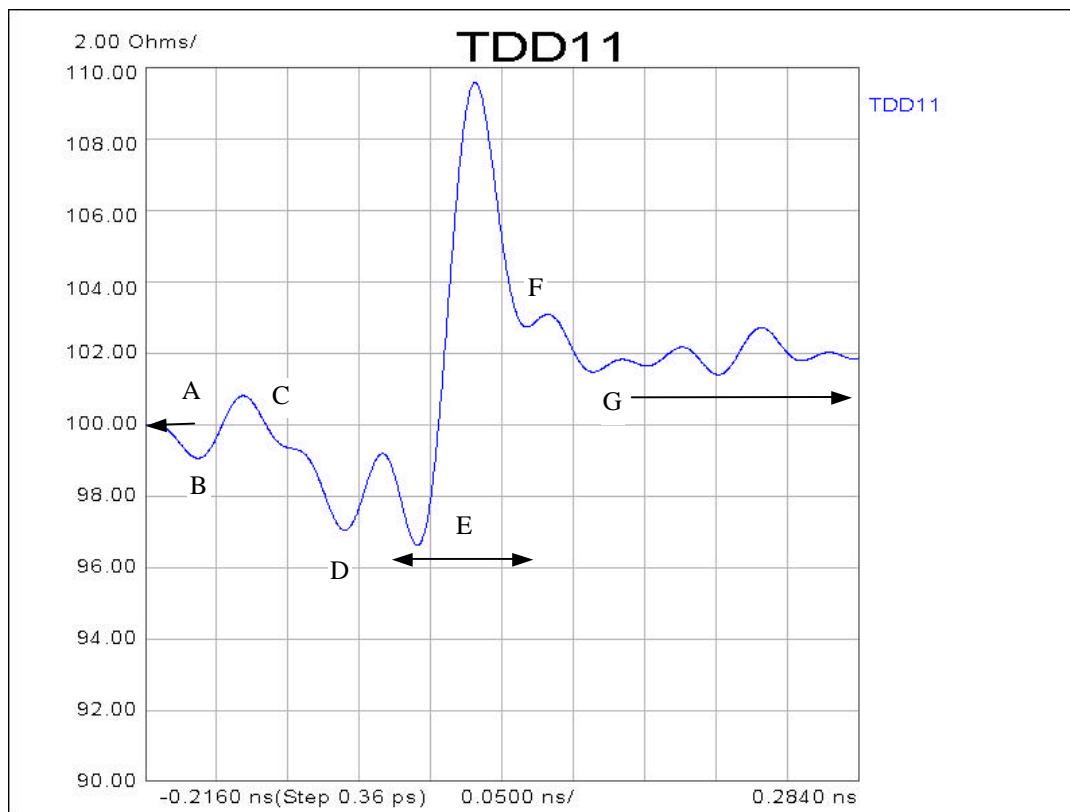

Feature Key:

- A - Motherboard
- B - Thru hole via
- C - Microstrip
- D - SMT pad
- E - Connector
- F - Contact interface
- G - Paddle card



Molex iPASS™

■ Right-Angle Connector Insertion Loss

- 3 dB threshold > 12 GHz
- XFP, 10Gb/s, specification (up to 15GHz)

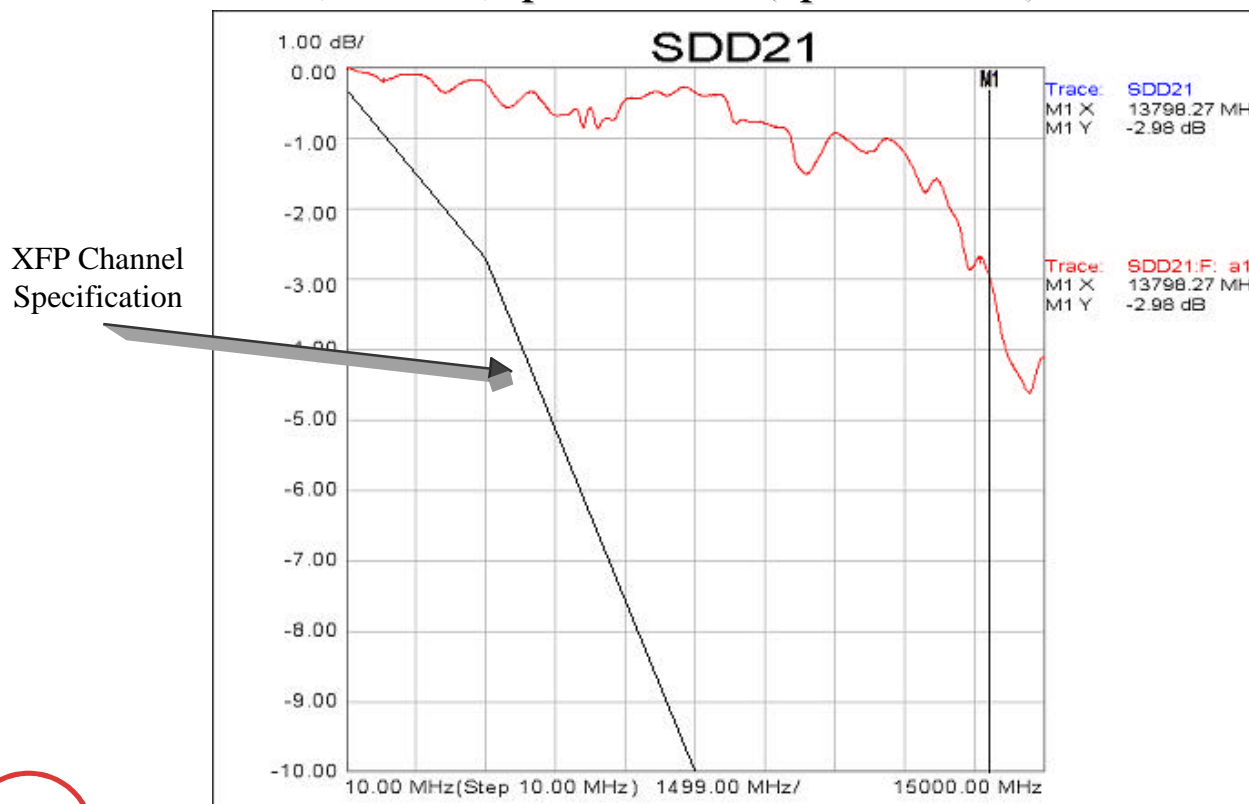

■ Right-Angle Connector Near-End Isolation

- Frequency-Domain Isolation, nearest-neighbor aggressor, long row
- Swept to 15 GHz
- 26 dB threshold at 10 GHz

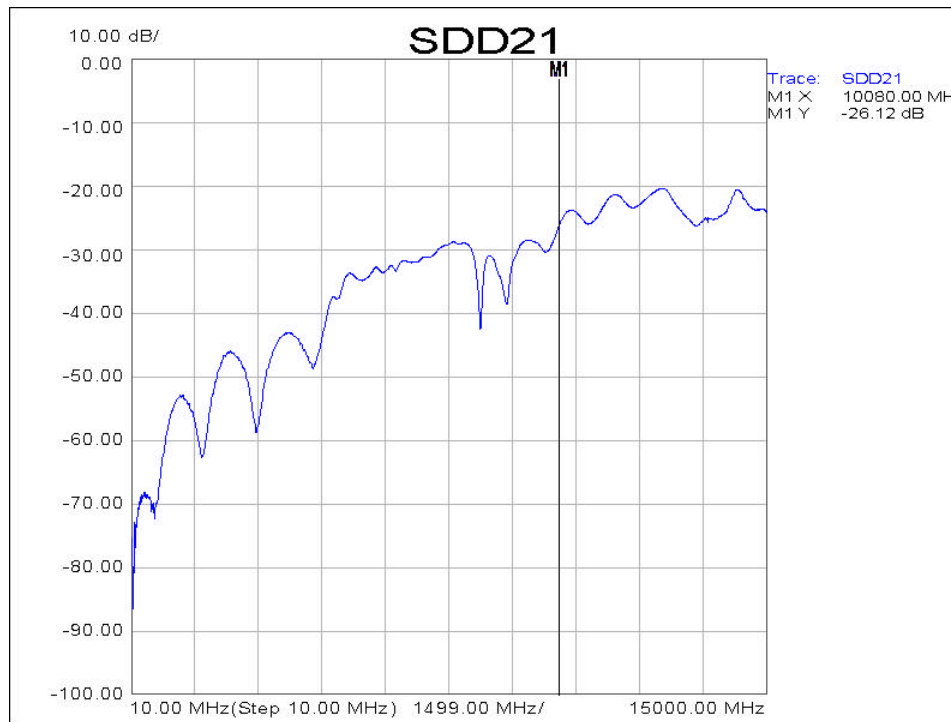

Molex iPASS™

■ Frequency-domain modeling

- Connector and Channel Empirical (single pair) and Analytical frequency-domain (multipair) models available
- Analytical models generated using CST

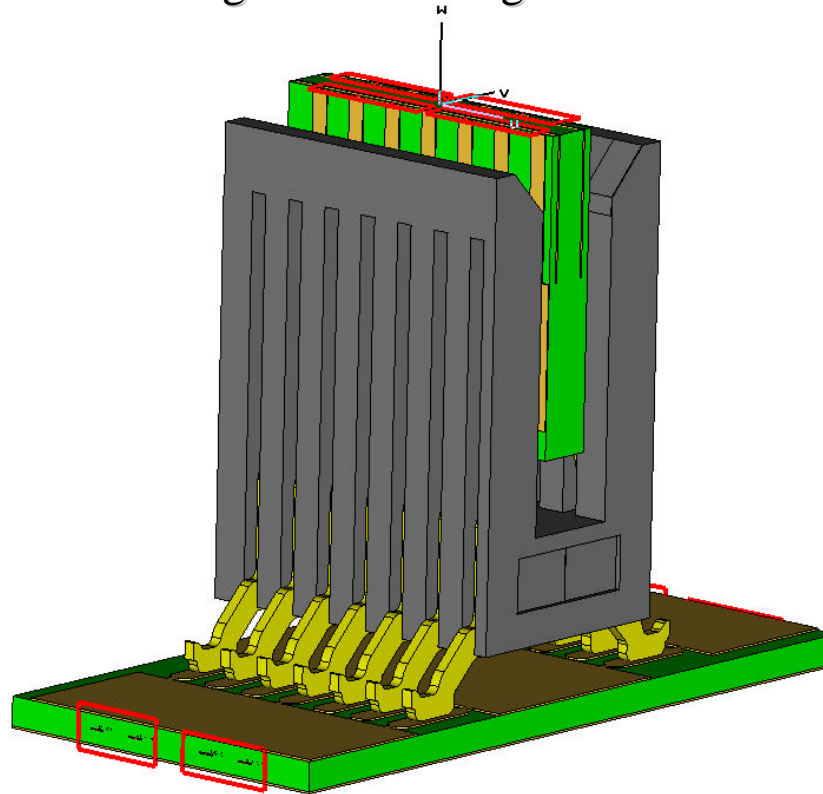

36 ckt External cables and cage

- Cable Assembly
 - Provides
 - Standard paddle card termination process consistent with current low cost methods. Compliant to the IPC 620 soldering specification.
 - Impedance controlled paddle card design enables equalization, minimizes crosstalk between pairs and provides space for the termination of 24 AWG raw cable.
 - Die cast backshell provides 360 degree shielding for EMI control and a rugged strain relief for the cable exit.
 - Low profile backshell design is compatible with the AMC (Advanced mezzanine card) form factor.
 - Epoxy molding process provides a secure strain relief for the termination area.
 - Flexible, intuitive, pull to release latch provides a reliable connection to the PCB connector and allows for stack-ability.

Molex iPASS™

■ Cable Assembly

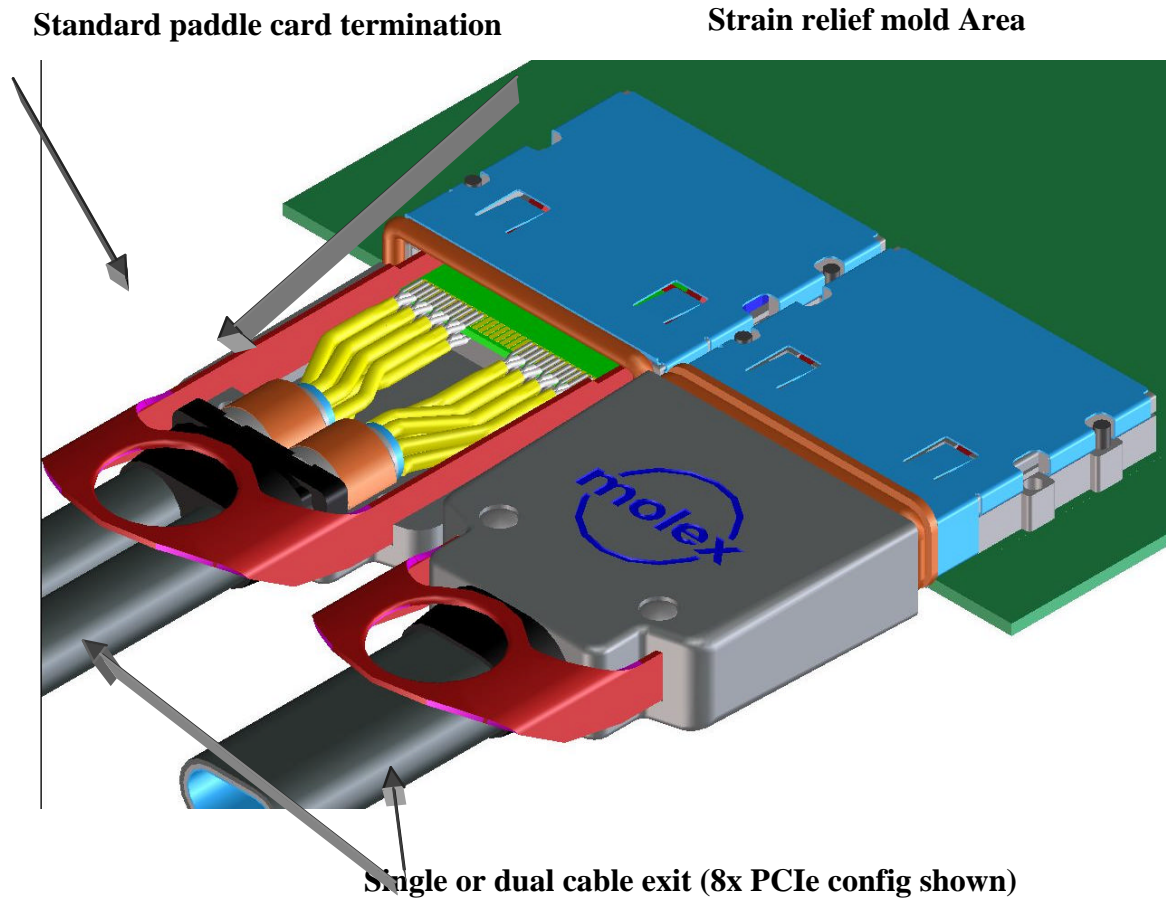

Connector Products Division: Signal Integrity Group



Molex iPASS™

■ Cable Assembly Test Setup

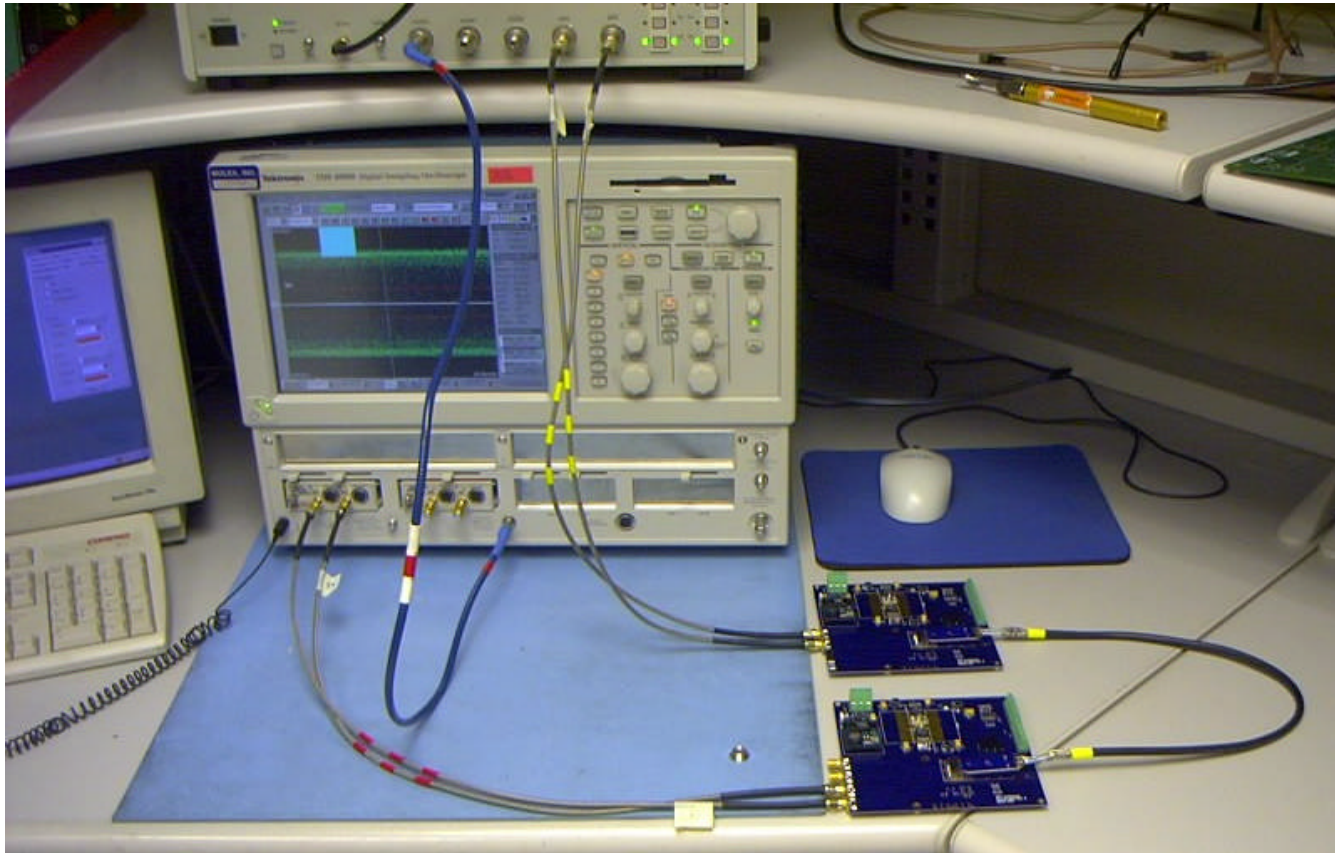

Connector Products Division: Signal Integrity Group



Molex iPASS™

■ Cable Assembly Test Setup Block Diagram

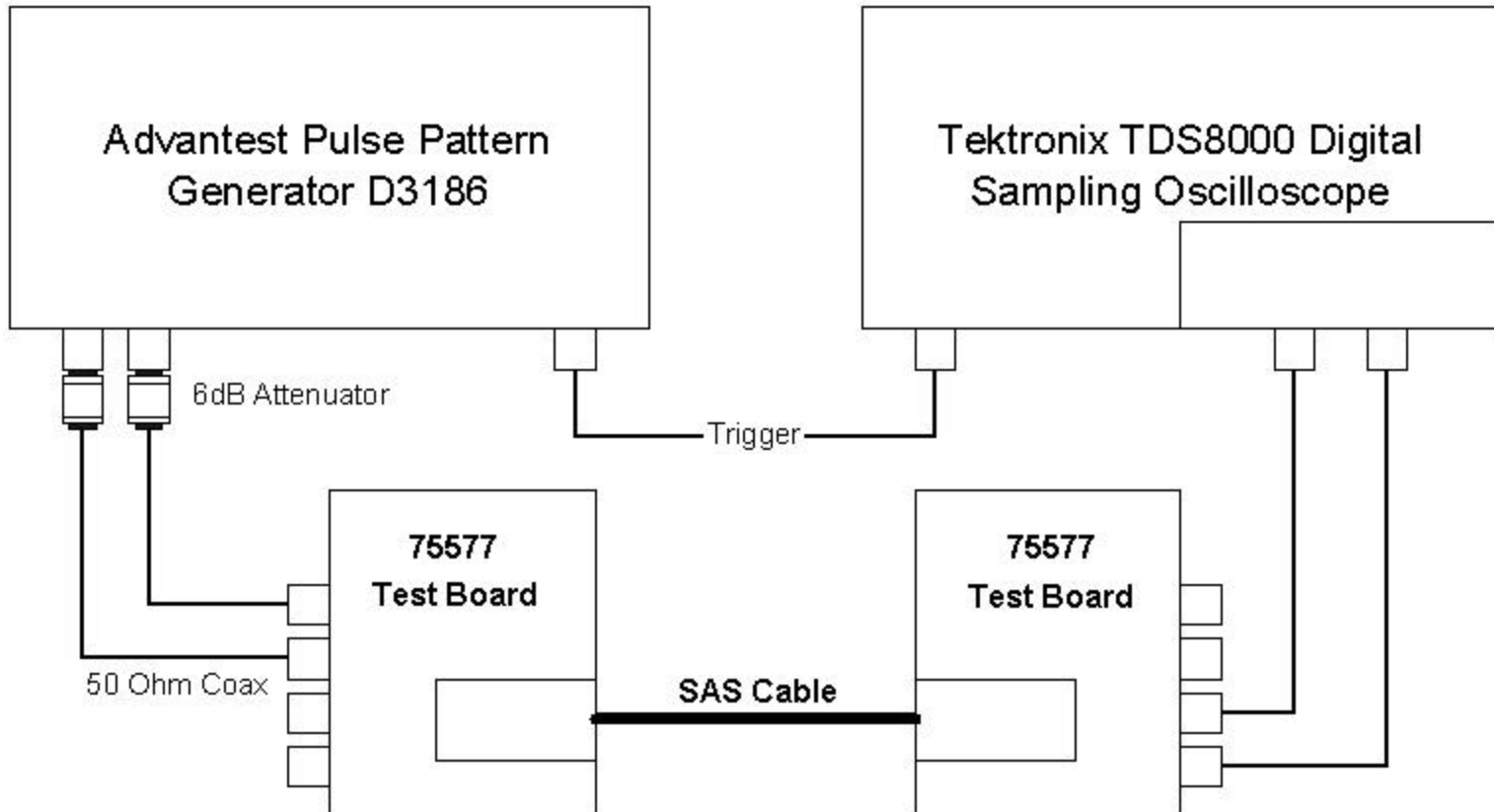

Molex iPASS™

■ Cable Assembly Test Setup Parameters

- **Signal Source:**
 - **Advantest Pulse Pattern Generator D3186**
 - **Source Rise Time:** 24 ps (20% - 80%)
 - **Data Pattern:** PBRS 2⁷-1
 - **Bit Rate (Gbps):** 6.0, 10.0
 - **Attenuation:** Attenuator (6dB)
 - **Signal Input:** 800 mVpp
- **Measuring Instruments:**
 - **Tektronix TDS 8000 Sampling Oscilloscope**
 - **Tektronix 80E04 Sampling Head**
- **Cable:** 24 AWG Spectra Strip
- **Test Board:** 75577 Rev A



Molex iPASS™

■ Cable Assembly Eye Pattern (Gen 2, 6 Gbps)

(3 meters)

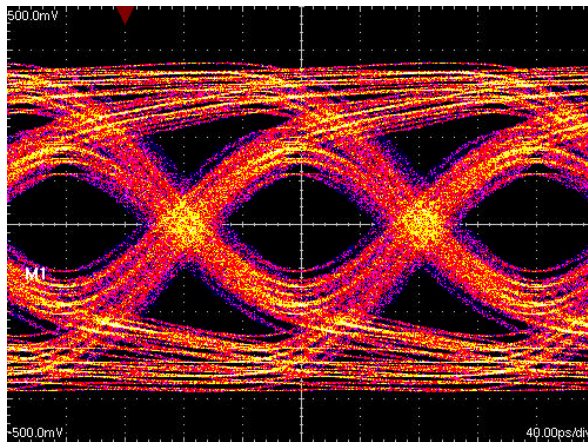

(1 meter)

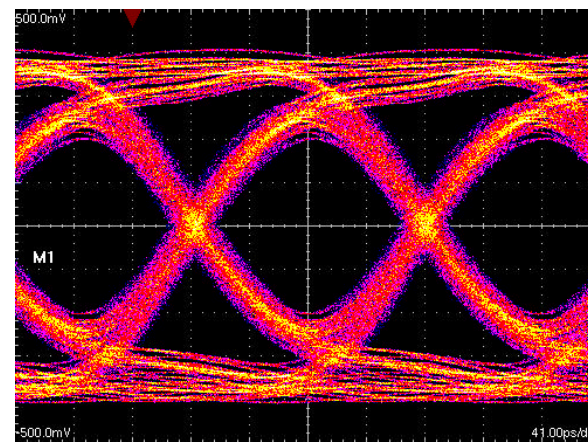

Parameters	Results (3 meters)	Results (1 meter)	Reference	Units
Voltage rail-to-rail	755.0	791.0	860.0	mVpp (diff)
Eye Height	213.5	391.9	794.6	mVpp (diff)
Jitter (pp)	62.4	37.27	10.0	ps



Molex iPASS™

■ Cable Assembly Insertion Loss

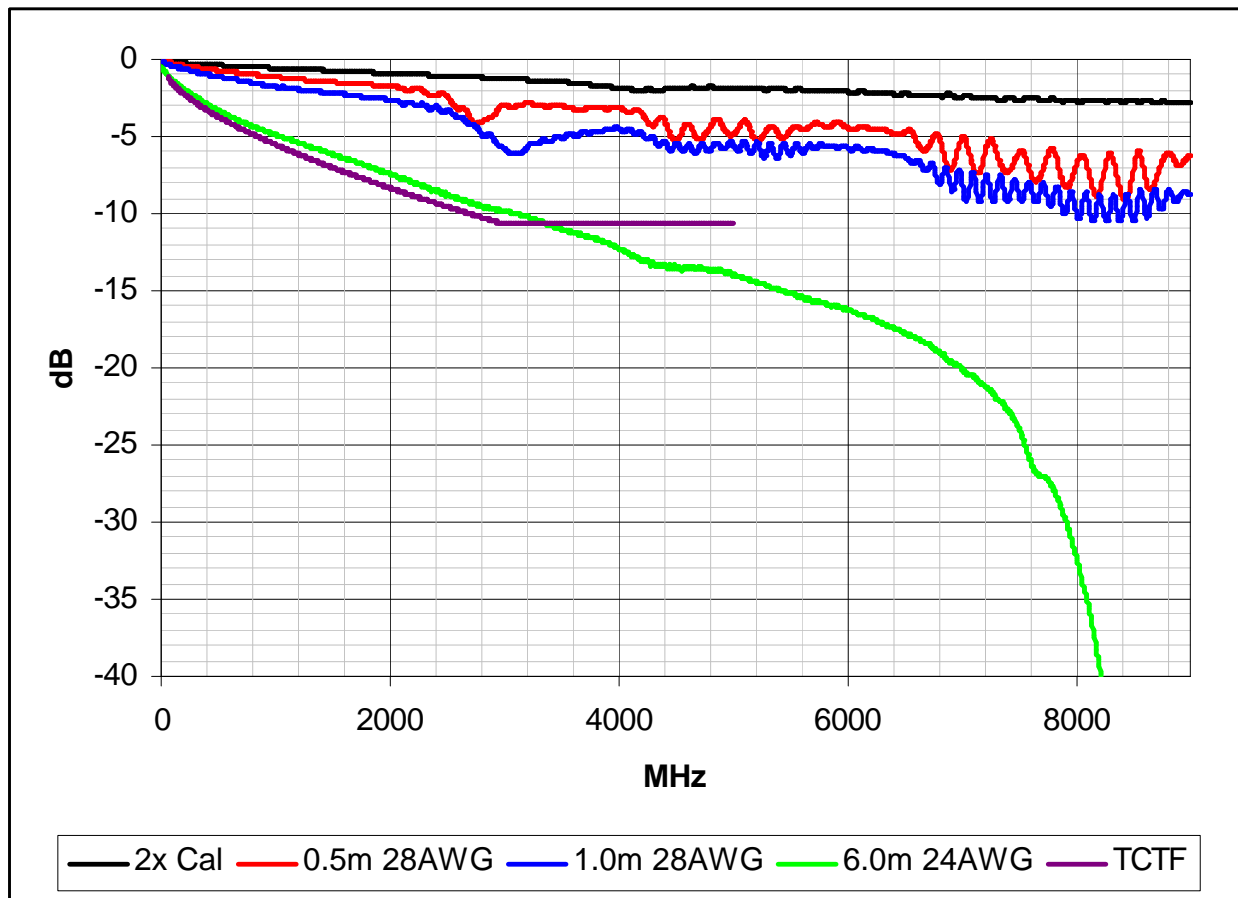

Connector Products Division: Signal Integrity Group



Molex iPASS™

■ Cable Assembly Crosstalk — 1 meter 28AWG NEXT

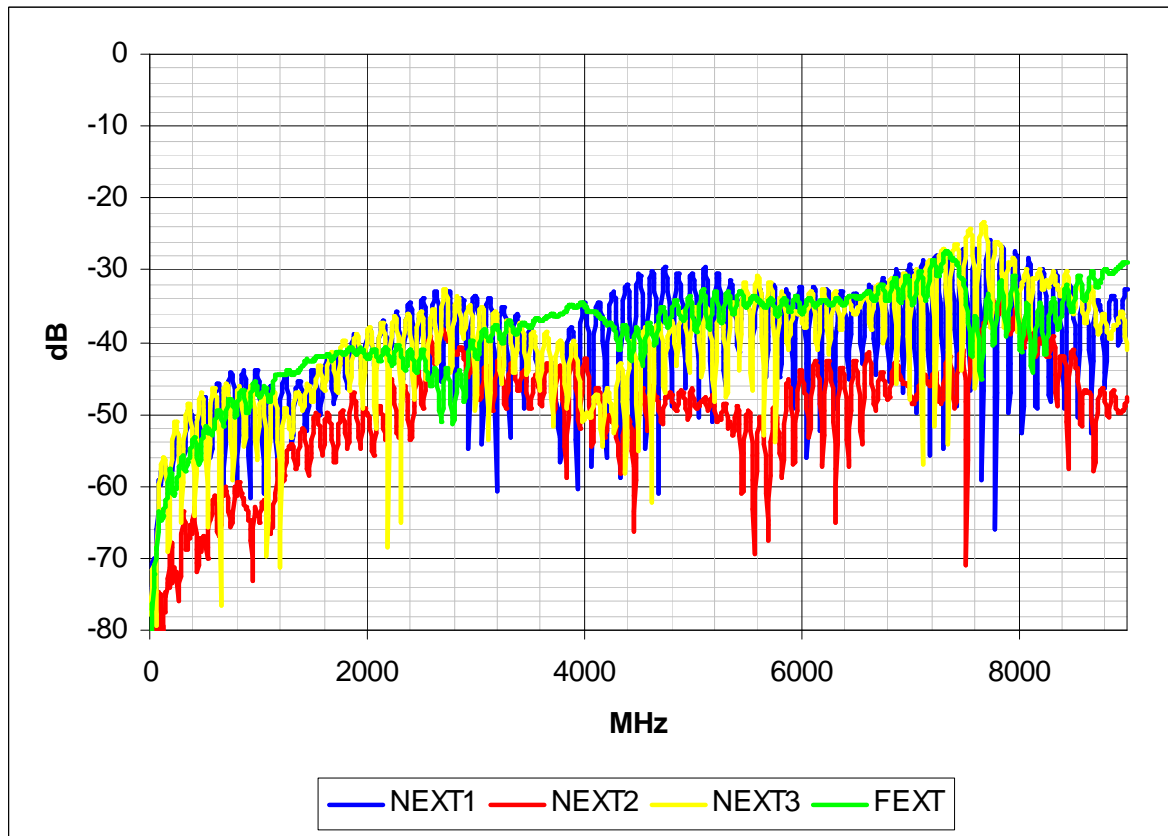

Molex iPASS™

■ Cable Assembly Crosstalk

– 1 meter 28AWG Power-Sum NEXT

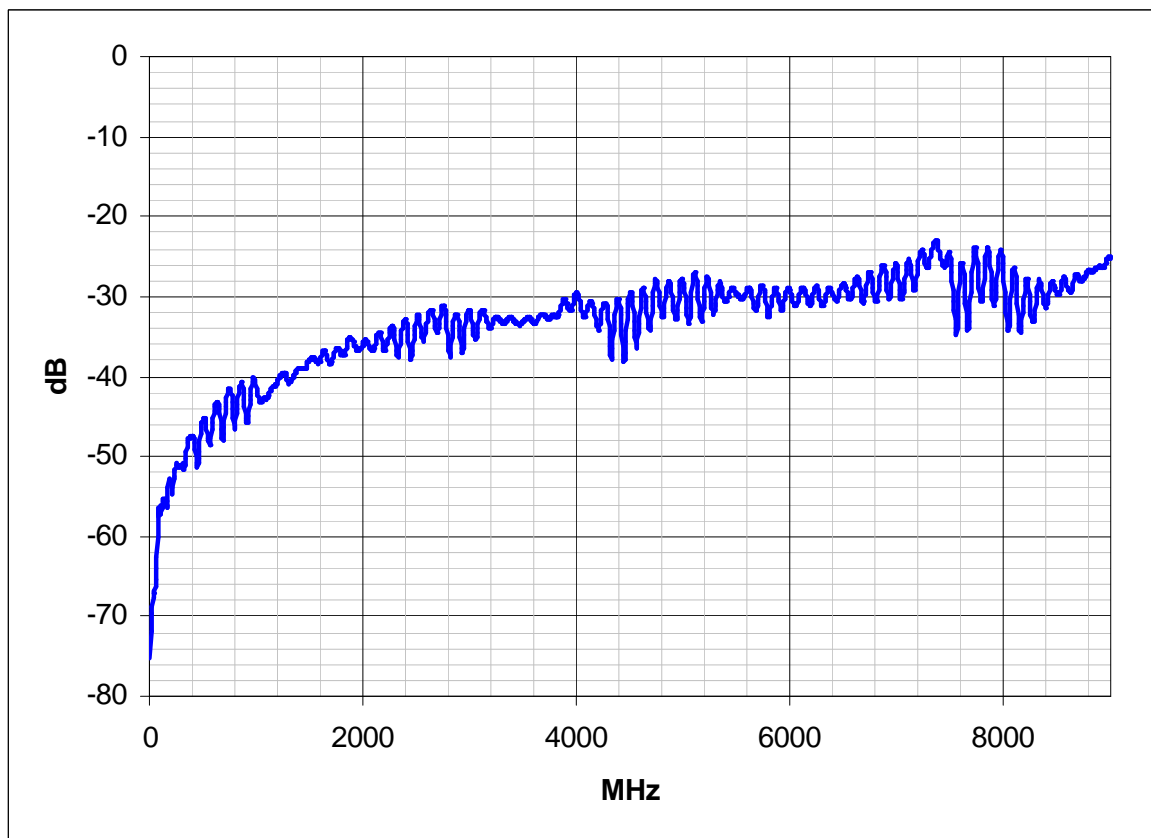

Molex iPASS™

- Cable Termination Impedance
 - Test Fixture w/ Assembly (Near End)

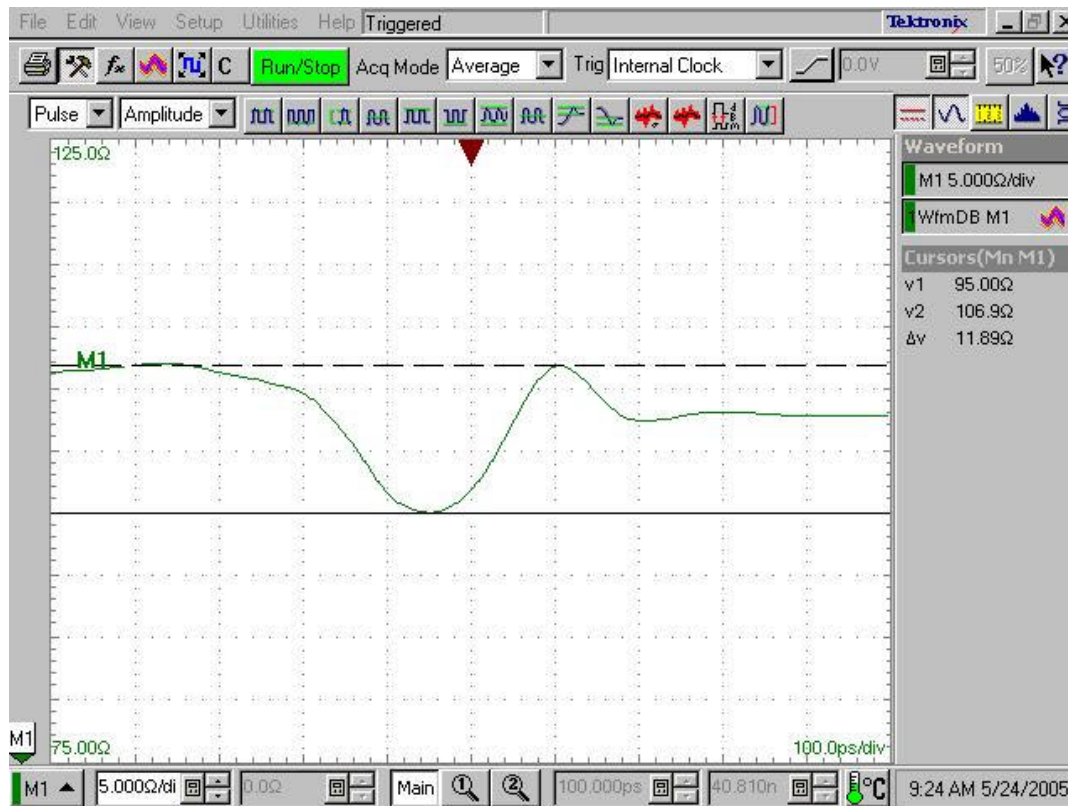

The 4x,8x Solution

For More Information Contact:

- Debbie Kiley
Host Connector/Hoods
-Email: debbie.kiley@molex.com
-Telephone: (630)527-4643
- Chad Jameson
External Cables / Guide frame
-Email: chad.jameson@molex.com
-Telephone: (501)851-4850 ext.403
- Galen Fromm
Signal Integrity
-Email: galen.fromm@molex.com
-Telephone: (630) 718-5270
- Jairo Guerrero
Internal Cables
-Email: jairo.guerrero@molex.com
-Telephone: 011-52-3336681408
- Jay Neer
Standards Related Activity / General Product
Email: jay.neer@molex.com
Telephone: (561)251-8016