

## 5 Physical layer

### 5.1 Physical layer overview

The physical layer defines:

- a) passive interconnect (e.g., connectors and cable assemblies); and
- b) transmitter and receiver device electrical characteristics.

Within this standard, references to connector gender use the terms plug and receptacle as equivalent to the terms free and fixed, respectively, that may be used in the references that define the connectors. Fixed and free terminology has no relationship to the application of the connector.

### 5.2 Passive interconnect

#### 5.2.1 SATA connectors and cable assemblies

Figure 49 shows a schematic representation of the connectors and cables defined by SATA (see ATA/ATAPI-7 V3). A SATA host is analogous to a SAS initiator device and a SATA device is analogous to a SAS target device.

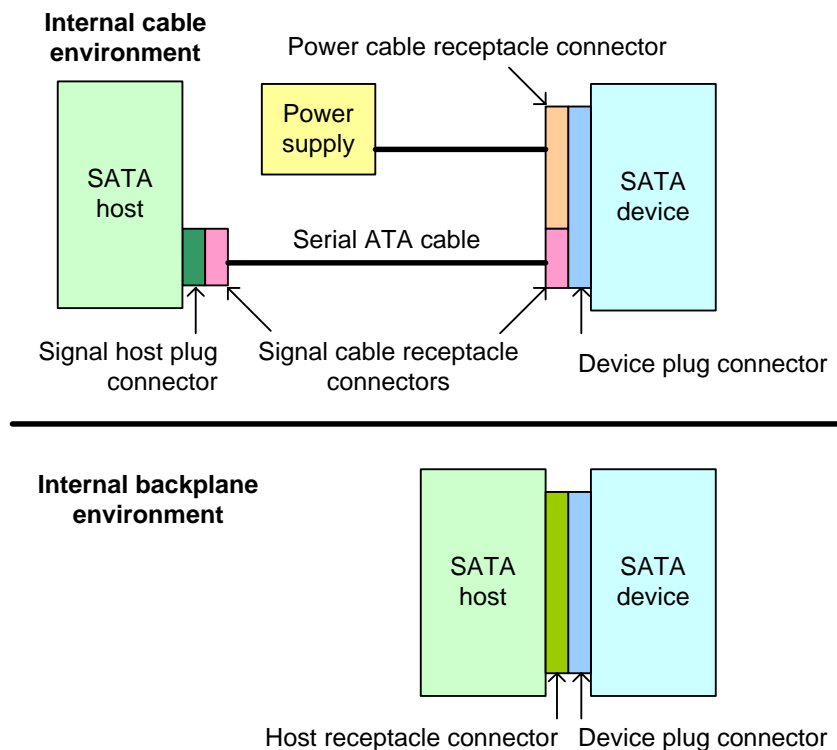
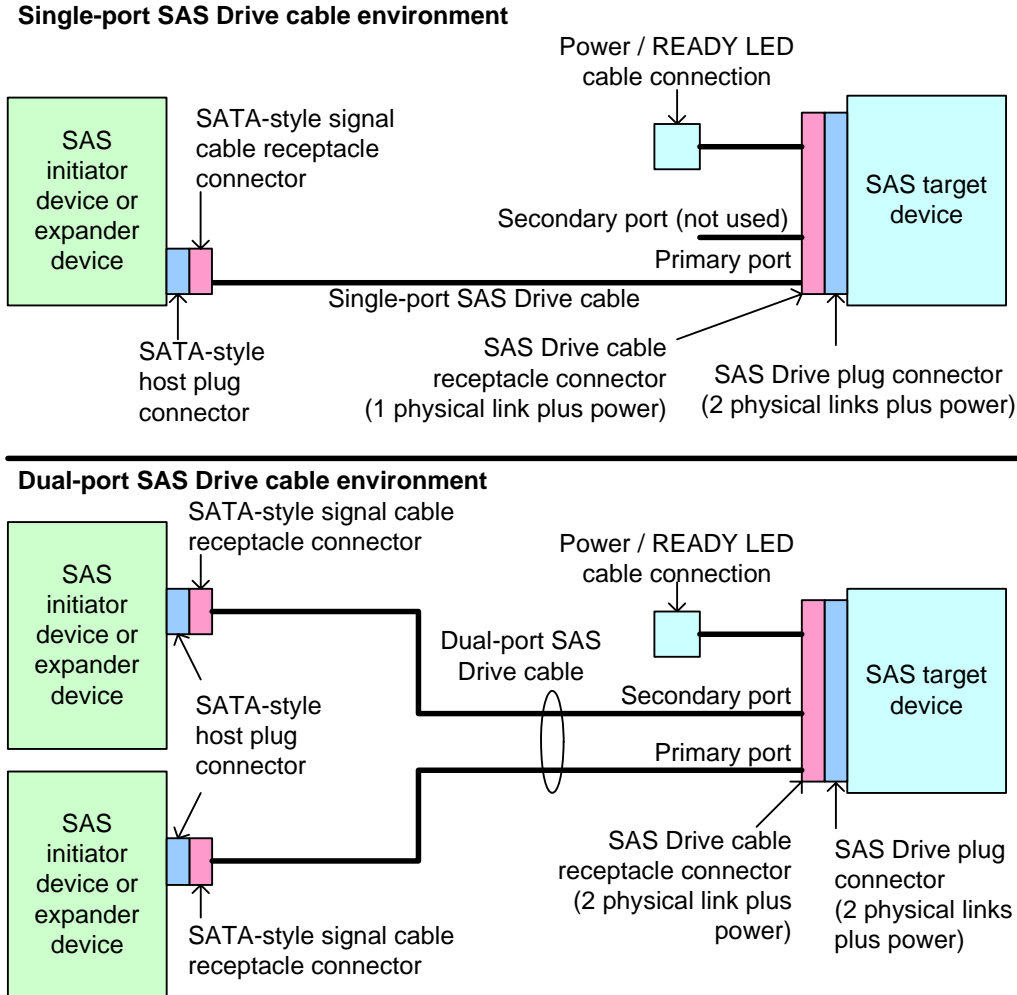

Figure 49 — SATA connectors and cables

#### 5.2.2 SAS connectors and cables

This standard defines SAS Drive cable, SAS Drive backplane, SAS internal cable, and SAS external cable environments.

Figure 50 shows a schematic representation of the SAS Drive cable environments.



**Figure 50 — SAS Drive cable environments**

Figure 51 shows a schematic representation of the SAS Drive backplane environment.

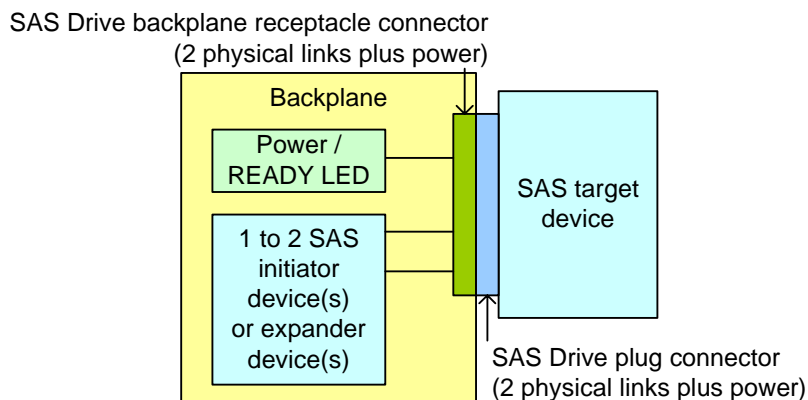

**Figure 51 — SAS Drive backplane environment**

Figure 52 shows a schematic representation of the SAS external cable environment.

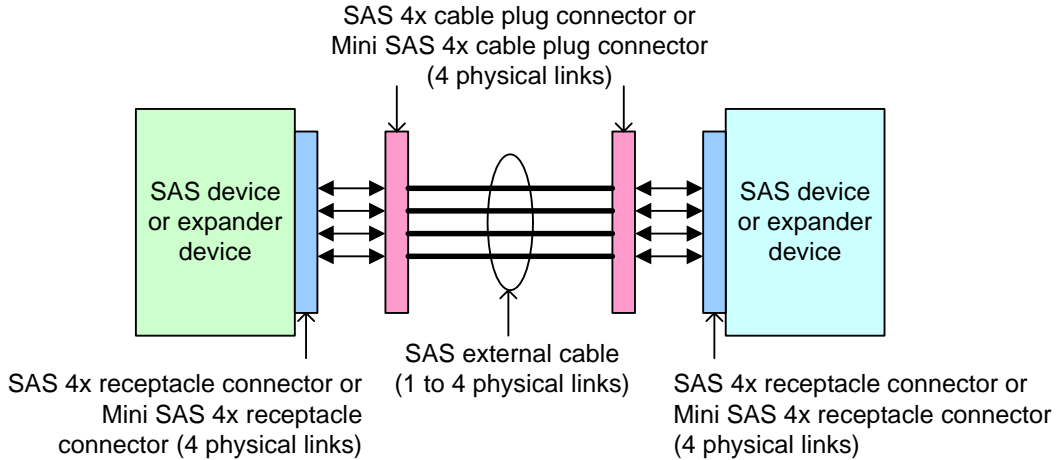

**Figure 52 — SAS external cable environment**

Figure 53 shows a schematic representation of the SAS internal cable environment attaching a controller to a backplane using a SAS internal symmetric cable.

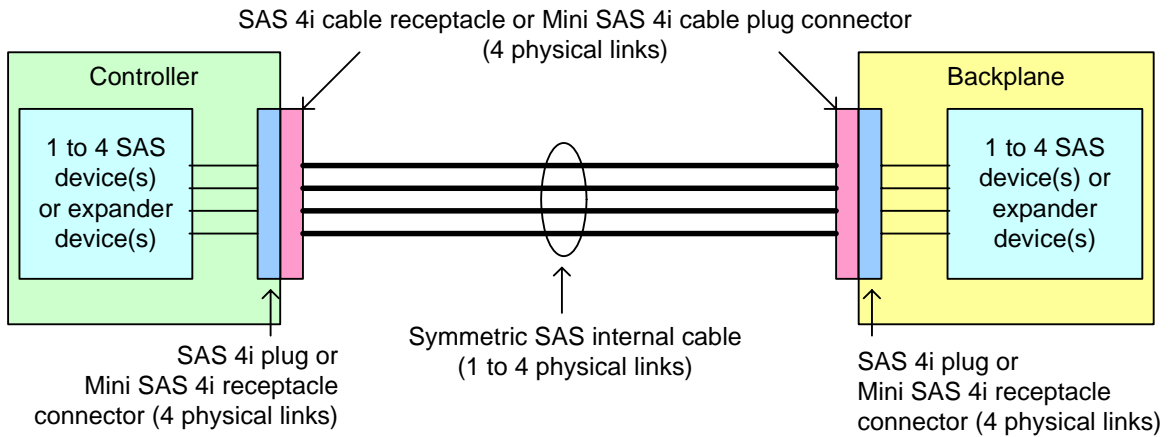

**Figure 53 — SAS internal symmetric cable environment - controller to backplane**

A SAS internal symmetric cable provides one to four physical links, and may be used as any combination of wide links and narrow links (see 4.1.3) using those physical links.

Figure 54 shows a schematic representation of the SAS internal cable environment attaching a controller to a controller using a SAS internal symmetric cable. Two controllers may also be attached together with a SAS internal symmetric cable. If SAS 4i connectors are used, all four physical links are used (see 5.2.4.1.2).

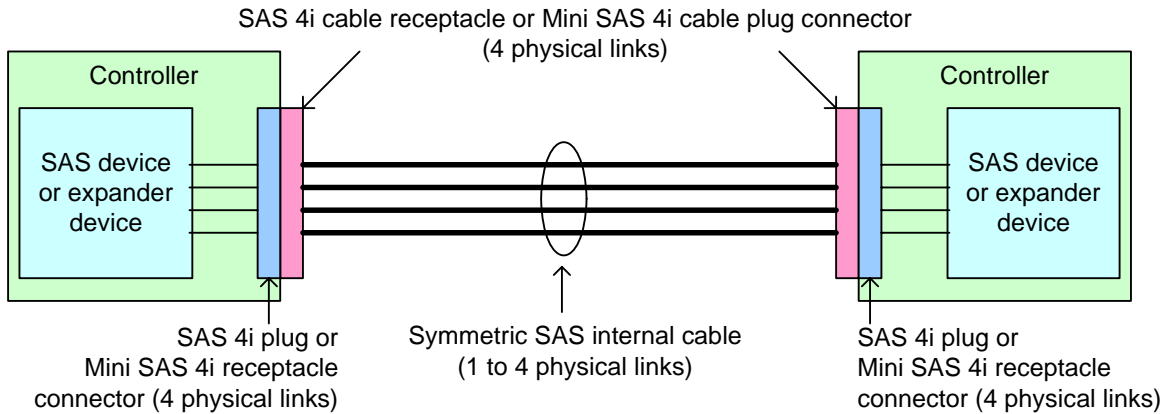

**Figure 54 — SAS internal symmetric cable environment - controller to controller**

Figure 55 shows a schematic representation of the SAS internal cable environment using a SAS controller-based fanout cable.

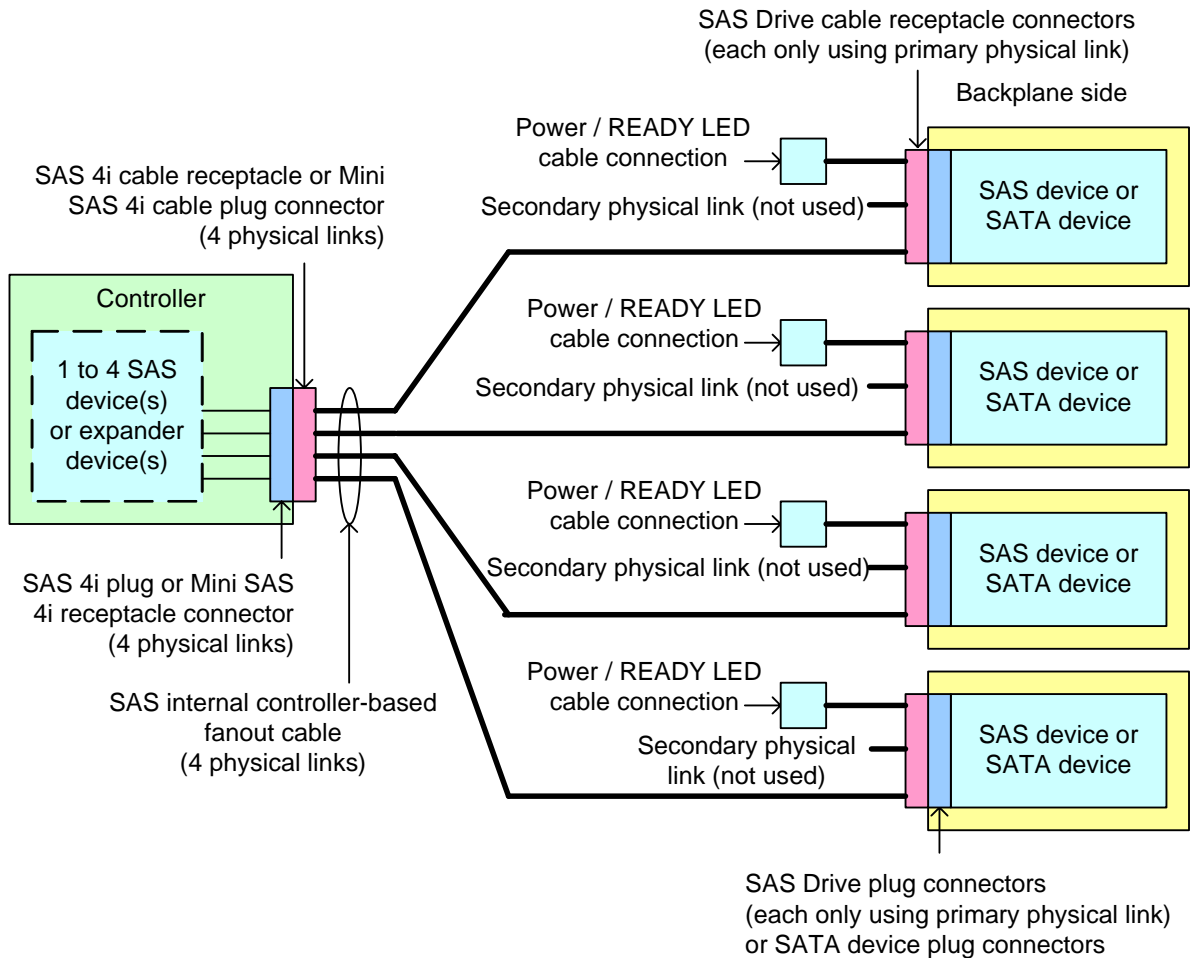

**Figure 55 — SAS internal controller-based fanout cable environment**

Figure 56 shows a schematic representation of the SAS internal cable environment using a SAS backplane-based fanout cable.

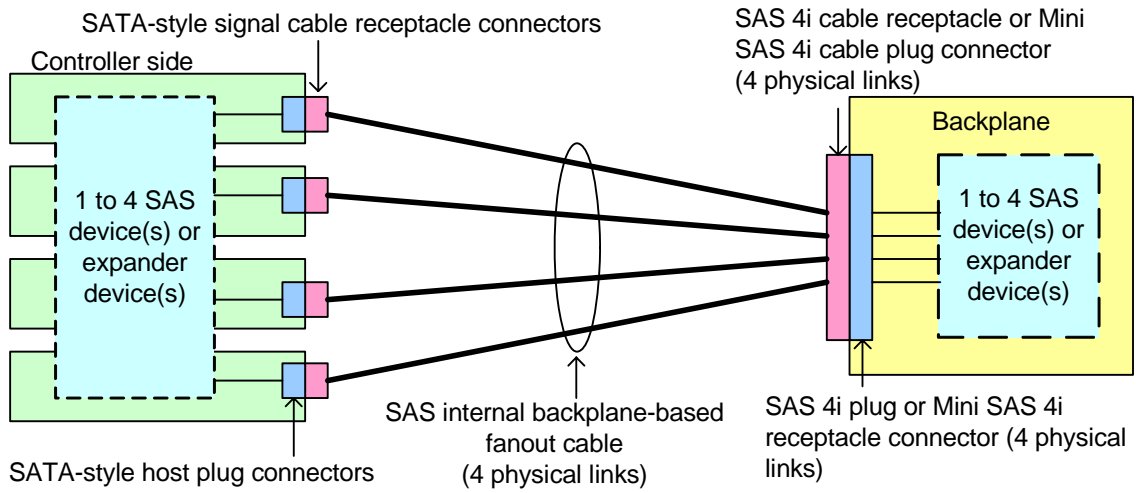

**Figure 56 — SAS internal backplane-based fanout cable environment**

## 5.2.3 Connectors

### 5.2.3.1 Connectors overview

Table 22 summarizes the connectors defined in this standard.

**Table 22 — Connectors**

Type of connector	Physical links	Reference	Attaches to		
			Type of connector	Physical links	Reference
<b>SAS Drive connectors</b>					
SAS Drive plug	2	5.2.3.2.1.1	SAS Drive cable receptacle	1 or 2	5.2.3.2.1.2
			SAS Drive backplane receptacle	2	5.2.3.2.1.3
SAS Drive cable SATA-style signal cable receptacle	1	ATA/ATAPI-7 V3	SATA-style host plug	1	ATA/ATAPI-7 V3
SAS Drive cable receptacle	1 or 2	5.2.3.2.1.2	SAS Drive plug	2	5.2.3.2.1.1
			SATA device plug	1	ATA/ATAPI-7 V3
SAS Drive backplane receptacle	2	5.2.3.2.1.3	SAS Drive plug	2	5.2.3.2.1.1
			SATA device plug	1	ATA/ATAPI-7 V3
<b>SAS internal connectors</b>					
SAS 4i cable receptacle	4	5.2.3.2.2.1	SAS 4i plug	4	5.2.3.2.2.2
SAS 4i plug	4	5.2.3.2.2.2	SAS 4i cable receptacle	4	5.2.3.2.2.1
Mini SAS 4i cable plug	4	5.2.3.2.3.1	Mini SAS 4i receptacle	4	5.2.3.2.3.2
Mini SAS 4i receptacle	4	5.2.3.2.3.2	Mini SAS 4i cable plug	4	5.2.3.2.3.1
<b>SAS external connectors</b>					
SAS 4x cable plug	4	5.2.3.3.1.1	SAS 4x receptacle	4	5.2.3.3.1.2
SAS 4x receptacle	4	5.2.3.3.1.2	SAS 4x cable plug	4	5.2.3.3.1.1
Mini SAS 4x cable plug	4	5.2.3.3.2.1	Mini SAS 4x receptacle	4	5.2.3.3.2.2
Mini SAS 4x receptacle	4	5.2.3.3.2.2	Mini SAS 4x plug	4	5.2.3.3.2.1

The general SAS icon (see M.1) should be placed on or near each SAS connector.

### 5.2.3.2 SAS internal connectors

#### 5.2.3.2.1 SAS Drive connectors

##### 5.2.3.2.1.1 SAS Drive plug connector

The SAS Drive plug connector is the SAS Device Free (Plug) connector defined in SFF-8482.

See SFF-8223, SFF-8323, and SFF-8523 for the SAS Drive plug connector locations on common form factors.

Figure 57 shows the SAS Drive plug connector.

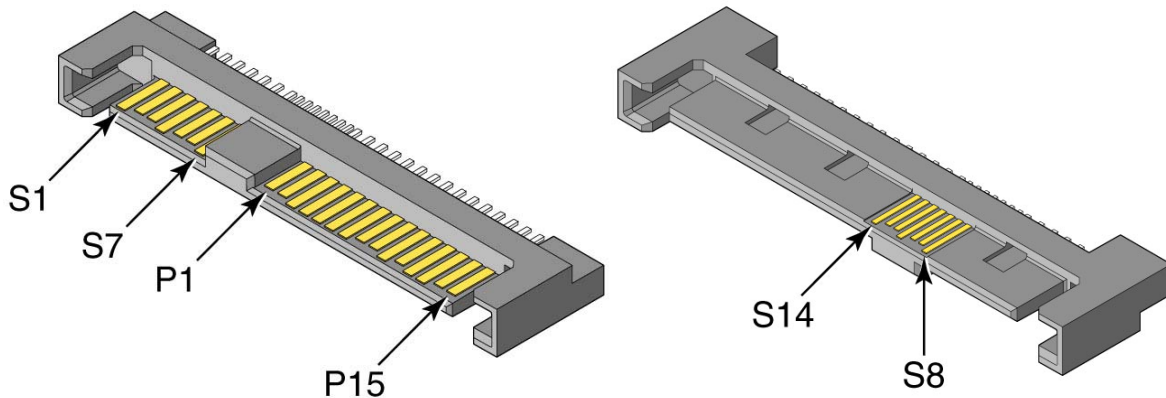

**Figure 57 — SAS Drive plug connector**

Table 23 (see 5.2.3.2.1.4) defines the pin assignments for the SAS Drive plug connector.

#### 5.2.3.2.1.2 SAS Drive cable receptacle connector

The SAS Drive cable receptacle connector is the SAS Internal Cable Fixed (Receptacle) connector defined in SFF-8482.

The single-port version attaches to:

- a SAS Drive plug connector, providing contact for the power pins and only the primary physical link; or
- a SATA device plug connector, providing contact for the power pins and the primary physical link.

Figure 58 shows the single-port version of the SAS Drive cable receptacle connector.

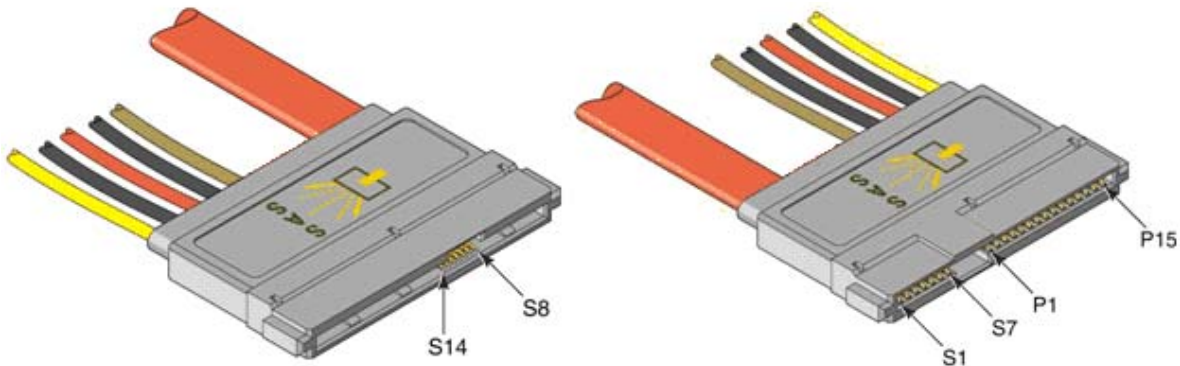
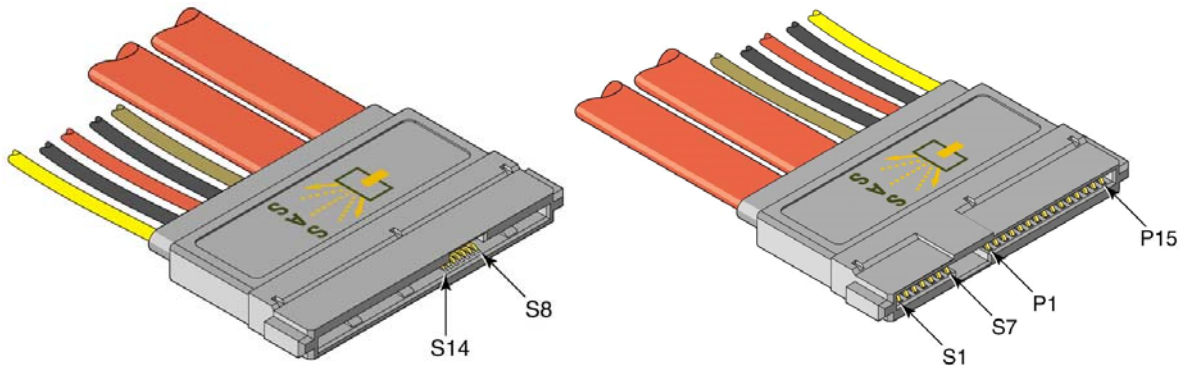

**Figure 58 — Single-port SAS Drive cable receptacle connector**

The dual-port version attaches to:

- a SAS Drive plug connector, providing contact for the power pins and only the primary physical link;
- a SAS Drive plug connector, providing contact for the power pins and both the primary and secondary physical links; or
- a SATA device plug connector, providing contact for the power pins and the primary physical link.

Figure 59 shows the dual-port version of the SAS Drive cable receptacle connector.



**Figure 59 — Dual-port SAS Drive cable receptacle connector**

Table 23 (see 5.2.3.2.1.4) defines the pin assignments for the SAS Drive cable receptacle connector. The secondary physical link (i.e., pins S8 through S14) is not supported by the single-port internal cable receptacle.

#### 5.2.3.2.1.3 SAS Drive backplane receptacle connector

The SAS Drive backplane receptacle connector is the SAS Backplane Fixed (Receptacle) connector defined in SFF-8482.

The SAS Drive backplane receptacle connector attaches to:

- a SAS Drive plug connector, providing contact for the power pins and only the primary physical link;
- a SAS Drive plug connector, providing contact for the power pins and both primary and secondary physical links; or
- a SATA device plug connector, providing contact for the power pins and the primary physical link.

Figure 60 shows the SAS Drive backplane receptacle connector.

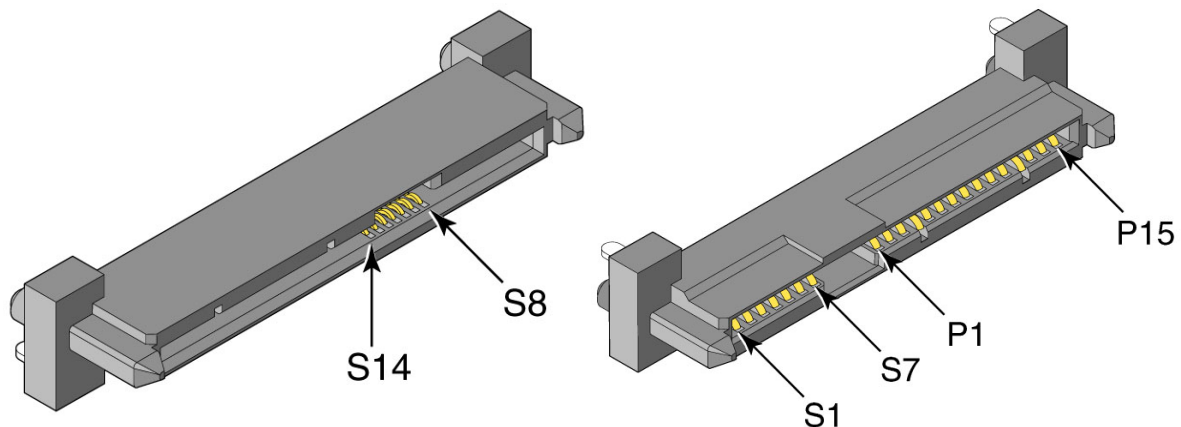

**Figure 60 — SAS Drive backplane receptacle connector**

Table 23 (see 5.2.3.2.1.4) defines the pin assignments for the SAS Drive backplane receptacle connector.

#### 5.2.3.2.1.4 SAS Drive connector pin assignments

Table 23 defines the SAS target device pin assignments for the SAS Drive plug connector (see 5.2.3.2.1.1), the SAS Drive cable receptacle connector (see 5.2.3.2.1.2), and the SAS Drive backplane receptacle connector (see 5.2.3.2.1.3). The TP+, TP-, RP+, and RP- signals are used by the primary physical link. The TS+, TS-, RS+, and RS- signals are used by the secondary physical link, if any.



Table 23 — SAS Drive connector pin assignments

Segment	Pin	Name
Primary signal	S1	GROUND
	S2	RP+
	S3	RP-
	S4	GROUND
	S5	TP-
	S6	TP+
	S7	GROUND
Secondary signal <sup>a</sup>	S8	GROUND
	S9	RS+
	S10	RS-
	S11	GROUND
	S12	TS-
	S13	TS+
	S14	GROUND
Power	P1	V <sub>33</sub> <sup>b</sup>
	P2	V <sub>33</sub> <sup>b</sup>
	P3	V <sub>33</sub> , precharge <sup>b</sup>
	P4	GROUND
	P5	GROUND
	P6	GROUND
	P7	V <sub>5</sub> , precharge <sup>b</sup>
	P8	V <sub>5</sub> <sup>b</sup>
	P9	V <sub>5</sub> <sup>b</sup>
	P10	GROUND
	P11	READY LED <sup>c</sup>
	P12	GROUND
	P13	V <sub>12</sub> , precharge <sup>b</sup>
	P14	V <sub>12</sub> <sup>b</sup>
	P15	V <sub>12</sub> <sup>b</sup>

<sup>a</sup> S8 through S14 are no-connects on single-port implementations.

<sup>b</sup> Behind a SAS Drive plug connector, the precharge pin and each corresponding voltage pin shall be connected together on the SAS target device (e.g., the V<sub>5</sub>, precharge pin P7 is connected to the two V<sub>5</sub> pins P8 and P9).

<sup>c</sup> Electrical characteristics for READY LED are defined in 5.4 and signal behavior is defined in 10.4.1. SATA devices use P11 for activity indication and staggered spin-up disable and have different electrical characteristics (see SATAII-EXT).

SAS Drive plug connector signal assignments, except for the addition of the secondary physical link when present, are in the same locations as they are in a SATA device plug connector (see ATA/ATAPI-7 V3).

On cable assemblies, backplanes, or any other connection media, the Tx signal from one internal connector pair shall be connected to the corresponding Rx signal of the other internal connector pair (i.e., the TP+ signal pin of connector 1 shall connect to the RP+ signal pin of connector 2) if there is an internal connector at both ends of the transmission media.

### 5.2.3.2.2 SAS 4i connectors

#### 5.2.3.2.2.1 SAS 4i cable receptacle connector

The SAS 4i cable receptacle connector is the 4 Lane Cable Receptacle (fixed) with Backshell connector defined in SFF-8484.

Figure 61 shows the SAS 4i cable receptacle connector.

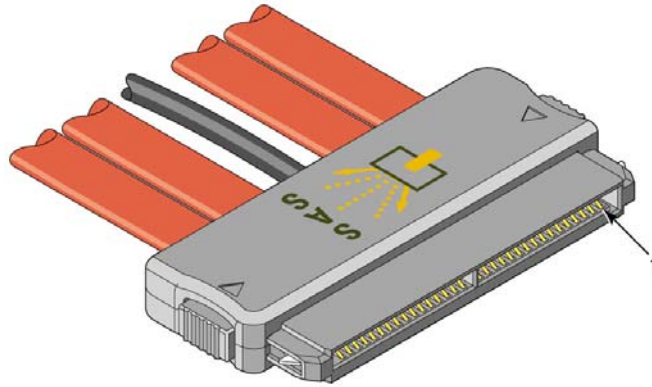

**Figure 61 — SAS 4i cable receptacle connector**

Table 24 and table 25 (see 5.2.3.2.2.3) define the pin assignments for the SAS 4i cable receptacle connector.

#### 5.2.3.2.2.2 SAS 4i plug connector

The SAS 4i plug connector is the 4 Lane Vertical Plug (free) or 4 Lane R/A Plug (free) connector defined in SFF-8484.

Figure 62 shows the SAS 4i plug connector.

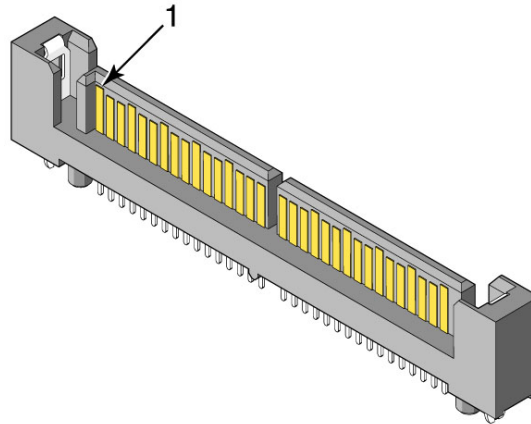

**Figure 62 — SAS 4i plug connector**

Table 24 and table 25 (see 5.2.3.2.2.3) define the pin assignments for the SAS 4i plug connector.

### 5.2.3.2.2.3 SAS 4i connector pin assignments

Table 24 defines the pin assignments for SAS 4i cable receptacle connectors (see 5.2.3.2.2.1) and SAS 4i plug connectors (see 5.2.3.2.2.2) for controller applications using one, two, three, or four of the physical links.

**Table 24 — Controller SAS 4i connector pin assignments and physical link usage**

Signal	Pin usage based on number of physical links supported by the cable assembly <sup>a</sup>			
	One	Two	Three	Four
Rx 0+	2	2	2	2
Rx 0-	3	3	3	3
Tx 0-	5	5	5	5
Tx 0+	6	6	6	6
Rx 1+	N/C	8	8	8
Rx 1-	N/C	9	9	9
Tx 1-	N/C	11	11	11
Tx 1+	N/C	12	12	12
Sideband 0	14	14	14	14
Sideband 1	15	15	15	15
Sideband 2	16	16	16	16
Sideband 3	17	17	17	17
Sideband 4	18	18	18	18
Sideband 5	19	19	19	19
Rx 2+	N/C	N/C	21	21
Rx 2-	N/C	N/C	22	22
Tx 2-	N/C	N/C	24	24
Tx 2+	N/C	N/C	25	25
Rx 3+	N/C	N/C	N/C	27
Rx 3-	N/C	N/C	N/C	28
Tx 3-	N/C	N/C	N/C	30
Tx 3+	N/C	N/C	N/C	31
SIGNAL GROUND	1, 4, 7, 10, 13, 20, 23, 26, 29, 32			
<sup>a</sup> N/C = not connected				

The use of the sideband signals by a controller is vendor-specific. One implementation of the sideband signals by a controller is an SGPIO initiator interface (see SFF-8485). Other implementations shall be compatible with the signal levels defined in SFF-8485.

Table 25 defines the pin assignments for SAS 4i plug connectors (see 5.2.3.2.2.1) and SAS 4i cable receptacle connectors (see 5.2.3.2.2.1) for backplane applications using one, two, three, or four of the physical links.

**Table 25 — Backplane SAS 4i connector pin assignments and physical link usage**

Signal	Pin usage based on number of physical links supported by the cable assembly <sup>a</sup>			
	One	Two	Three	Four
Rx 3+	N/C	N/C	N/C	2
Rx 3-	N/C	N/C	N/C	3
Tx 3-	N/C	N/C	N/C	5
Tx 3+	N/C	N/C	N/C	6
Rx 2+	N/C	N/C	8	8
Rx 2-	N/C	N/C	9	9
Tx 2-	N/C	N/C	11	11
Tx 2+	N/C	N/C	12	12
Sideband 5	14	14	14	14
Sideband 4	15	15	15	15
Sideband 3	16	16	16	16
Sideband 2	17	17	17	17
Sideband 1	18	18	18	18
Sideband 0	19	19	19	19
Rx 1+	N/C	21	21	21
Rx 1-	N/C	22	22	22
Tx 1-	N/C	24	24	24
Tx 1+	N/C	25	25	25
Rx 0+	27	27	27	27
Rx 0-	28	28	28	28
Tx 0-	30	30	30	30
Tx 0+	31	31	31	31
SIGNAL GROUND	1, 4, 7, 10, 13, 20, 23, 26, 29, 32			
<sup>a</sup> N/C = not connected				

The use of the sideband signals by a backplane is vendor-specific. One implementation of the sideband signals by a backplane is an SGPIO target interface (see SFF-8485). Other implementations shall be compatible with the signal levels defined in SFF-8485.

### 5.2.3.2.3 Mini SAS 4i connectors

#### 5.2.3.2.3.1 Mini SAS 4i cable plug connector

The Mini SAS 4i cable plug connector is the free (plug) cable connector defined in SFF-8087 with the 36 circuit size defined in SFF-8086.

Figure 63 shows the Mini SAS 4i cable plug connector.

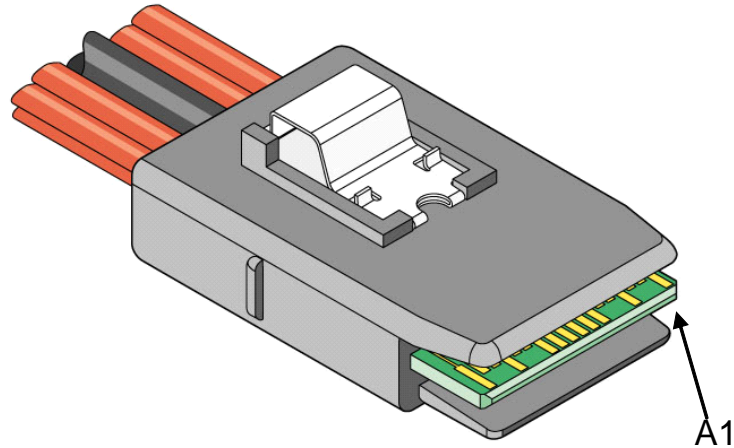

**Figure 63 — Mini SAS 4i cable plug connector**

Table 26 and table 27 (see 5.2.3.2.3.3) define the pin assignments for the Mini SAS 4i cable plug connector.

#### 5.2.3.2.3.2 Mini SAS 4i receptacle connector

The Mini SAS 4i receptacle connector is the fixed (receptacle) right angle connector defined in SFF-8087 with the 36 circuit size defined in SFF-8086.

Figure 64 shows the Mini SAS 4i receptacle connector.

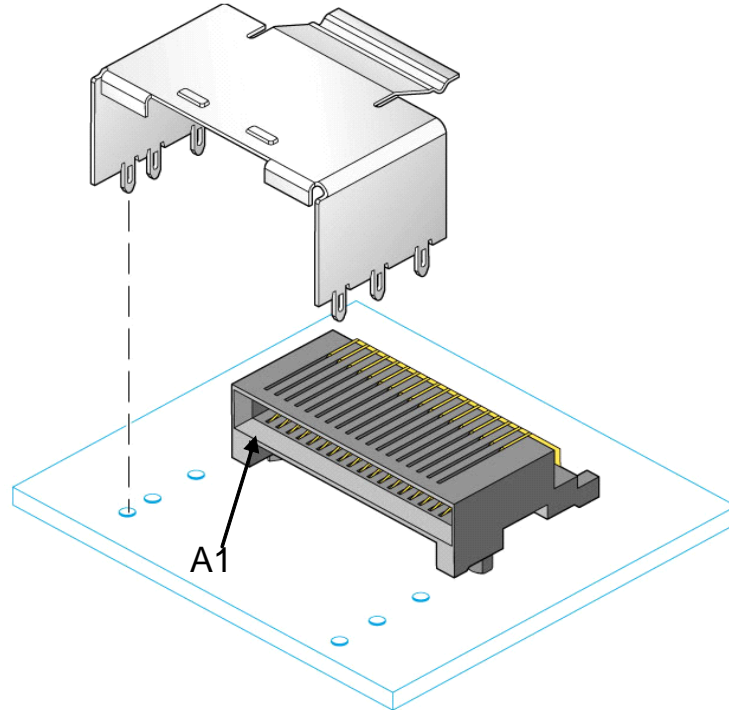

**Figure 64 — Mini SAS 4i receptacle connector**

Table 26 and table 27 (see 5.2.3.2.3.3) define the pin assignments for the Mini SAS 4i receptacle connector.

### 5.2.3.2.3.3 Mini SAS 4i connector pin assignments

Table 26 defines the pin assignments for Mini SAS 4i plug connectors (see 5.2.3.2.3.1) and Mini SAS 4i cable receptacle connectors (see 5.2.3.2.3.2) for controller applications using one, two, three, or four of the physical links.

**Table 26 — Controller Mini SAS 4i connector pin assignments and physical link usage**

Signal	Pin usage based on number of physical links supported by the cable assembly <sup>a</sup>			
	One	Two	Three	Four
Rx 0+	A2	A2	A2	A2
Rx 0-	A3	A3	A3	A3
Rx 1+	N/C	A5	A5	A5
Rx 1-	N/C	A6	A6	A6
Sideband 6	A8	A8	A8	A8
Sideband 3	A9	A9	A9	A9
Sideband 4	A10	A10	A10	A10
Sideband 5	A11	A11	A11	A11
Rx 2+	N/C	N/C	A13	A13
Rx 2-	N/C	N/C	A14	A14
Rx 3+	N/C	N/C	N/C	A16
Rx 3-	N/C	N/C	N/C	A17
Tx 0+	B2	B2	B2	B2
Tx 0-	B3	B3	B3	B3
Tx 1+	N/C	B5	B5	B5
Tx 1-	N/C	B6	B6	B6
Sideband 0	B8	B8	B8	B8
Sideband 1	B9	B9	B9	B9
Sideband 2	B10	B10	B10	B10
Sideband 7	B11	B11	B11	B11
Tx 2+	N/C	N/C	B13	B13
Tx 2-	N/C	N/C	B14	B14
Tx 3+	N/C	N/C	N/C	B16
Tx 3-	N/C	N/C	N/C	B17
SIGNAL GROUND	A1, A4, A7, A12, A15, A18, B1, B4, B7, B12, B15, B18			
<sup>a</sup> N/C = not connected				

The use of the sideband signals by a controller is vendor-specific. One implementation of the sideband signals by a controller is an SGPIO initiator interface (see SFF-8485). Other implementations shall be compatible with the signal levels defined in SFF-8485.

Table 27 defines the pin assignments for Mini SAS 4i plug connectors (see 5.2.3.2.3.1) and Mini SAS 4i cable receptacle connectors (see 5.2.3.2.3.2) for backplane applications using one, two, three, or four of the physical links.

**Table 27 — Backplane Mini SAS 4i connector pin assignments and physical link usage**

Signal	Pin usage based on number of physical links supported by the cable assembly <sup>a</sup>			
	One	Two	Three	Four
Rx 0+	A2	A2	A2	A2
Rx 0-	A3	A3	A3	A3
Rx 1+	N/C	A5	A5	A5
Rx 1-	N/C	A6	A6	A6
Sideband 0	A8	A8	A8	A8
Sideband 1	A9	A9	A9	A9
Sideband 2	A10	A10	A10	A10
Sideband 7	A11	A11	A11	A11
Rx 2+	N/C	N/C	A13	A13
Rx 2-	N/C	N/C	A14	A14
Rx 3+	N/C	N/C	N/C	A16
Rx 3-	N/C	N/C	N/C	A17
Tx 0+	B2	B2	B2	B2
Tx 0-	B3	B3	B3	B3
Tx 1+	N/C	B5	B5	B5
Tx 1-	N/C	B6	B6	B6
Sideband 6	B8	B8	B8	B8
Sideband 3	B9	B9	B9	B9
Sideband 4	B10	B10	B10	B10
Sideband 5	B11	B11	B11	B11
Tx 2+	N/C	N/C	B13	B13
Tx 2-	N/C	N/C	B14	B14
Tx 3+	N/C	N/C	N/C	B16
Tx 3-	N/C	N/C	N/C	B17
SIGNAL GROUND	A1, A4, A7, A12, A15, A18, B1, B4, B7, B12, B15, B18			
<sup>a</sup> N/C = not connected				

The use of the sideband signals by a backplane is vendor-specific. One implementation of the sideband signals by a backplane is an SGPIO target interface (see SFF-8485). Other implementations shall be compatible with the signal levels defined in SFF-8485.



### 5.2.3.3 SAS external connectors

#### 5.2.3.3.1 SAS 4x connectors

##### 5.2.3.3.1.1 SAS 4x cable plug connector

The SAS 4x cable plug connector is the 4X free (plug) connector with jack screws defined in SFF-8470. The SAS 4x cable plug connector shall not include keys and may include key slots. Key slots for the SAS 4x cable plug connector are not defined by this standard.

Figure 65 shows the SAS 4x cable plug connector.

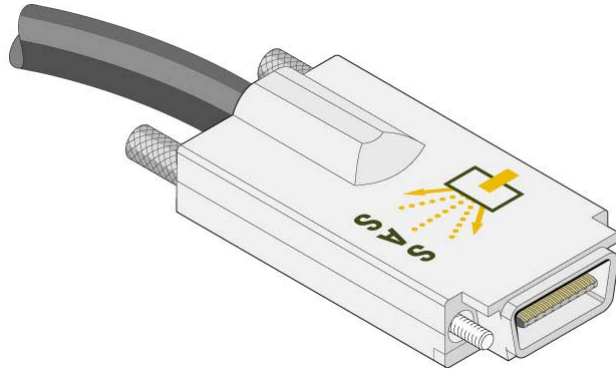

**Figure 65 — SAS 4x cable plug connector**

Table 28 (see 5.2.3.3.1.3) defines the pin assignments for the SAS 4x cable plug connector.

See 5.2.4.2.1 for icon recommendations for the SAS 4x cable plug connector.

##### 5.2.3.3.1.2 SAS 4x receptacle connector

The SAS 4x receptacle connector is the 4X fixed (receptacle) connector with jack screws defined in SFF-8470. The SAS 4x receptacle connector shall not include keys and may include key slots. Key slots for the SAS 4x receptacle connector are not defined by this standard.

A SAS 4x receptacle connector may be used by one or more SAS devices (e.g., one SAS device using physical links 0 and 3, another using physical link 1, and a third using physical link 2).

A SAS 4x receptacle connector shall be used by no more than one expander device at a time, and all physical links shall be used by the same expander port (i.e., all the expander phys shall have the same routing attribute (e.g., subtractive or table) (see 4.6.2)).

Figure 66 shows the SAS 4x receptacle connector.

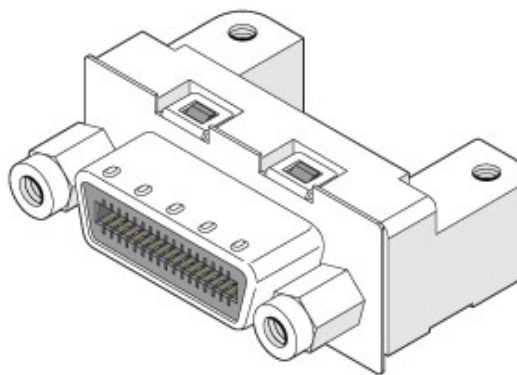

**Figure 66 — SAS 4x receptacle connector**

Table 28 (see 5.2.3.3.1.3) defines the pin assignments for the SAS 4x receptacle connector.

Based on what device is using the connector, the end device SAS icon (see figure M.2), enclosure out port SAS icon (see figure M.3), or enclosure in port SAS icon (see figure M.4) should be placed on or near the SAS 4x receptacle connector.

### 5.2.3.3.1.3 SAS 4x connector pin assignments

Table 28 defines the pin assignments for SAS 4x cable plug connectors (see 5.2.3.3.1.1) and SAS 4x receptacle connectors (see 5.2.3.3.1.2) for applications using one, two, three, or four of the physical links.

**Table 28 — SAS 4x connector pin assignments and physical link usage**

Signal	Pin usage based on number of physical links supported by the cable assembly <sup>a</sup>			
	One	Two	Three	Four
Rx 0+	S1	S1	S1	S1
Rx 0-	S2	S2	S2	S2
Rx 1+	N/C	S3	S3	S3
Rx 1-	N/C	S4	S4	S4
Rx 2+	N/C	N/C	S5	S5
Rx 2-	N/C	N/C	S6	S6
Rx 3+	N/C	N/C	N/C	S7
Rx 3-	N/C	N/C	N/C	S8
Tx 3-	N/C	N/C	N/C	S9
Tx 3+	N/C	N/C	N/C	S10
Tx 2-	N/C	N/C	S11	S11
Tx 2+	N/C	N/C	S12	S12
Tx 1-	N/C	S13	S13	S13
Tx 1+	N/C	S14	S14	S14
Tx 0-	S15	S15	S15	S15
Tx 0+	S16	S16	S16	S16
SIGNAL GROUND	G1 - G9			
CHASSIS GROUND	Housing			
<sup>a</sup> N/C = not connected				

SIGNAL GROUND shall not be connected to CHASSIS GROUND in the connector when used in a cable assembly.

### 5.2.3.3.2 Mini SAS 4x connectors

#### 5.2.3.3.2.1 Mini SAS 4x cable plug connector

The Mini SAS 4x cable plug connector is the free (plug) cable connector defined in SFF-8088 with the 26 circuit size defined in SFF-8086.

Figure 67 shows the Mini SAS 4x cable plug connector.

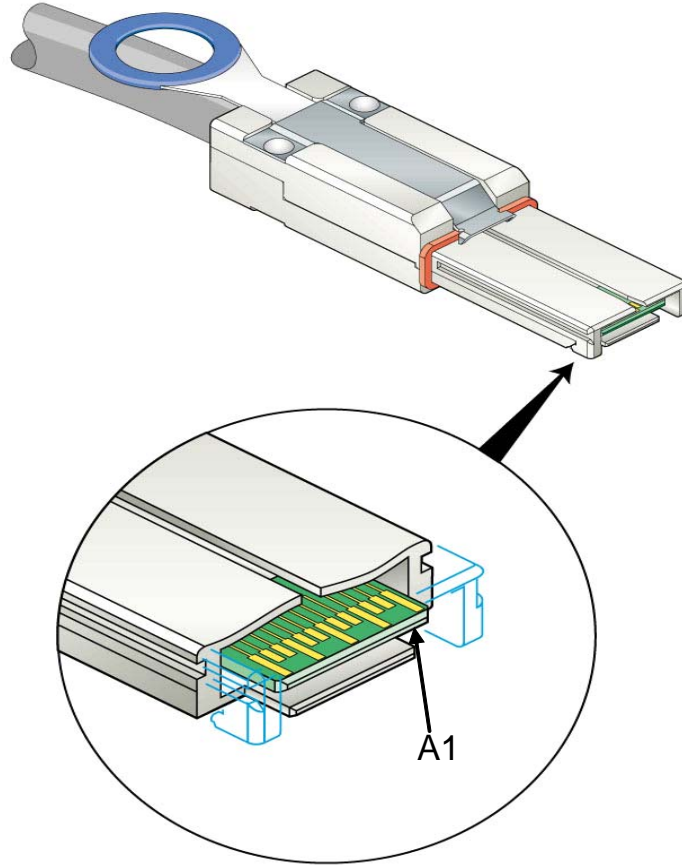

**Figure 67 — Mini SAS 4x cable plug connector**

Table 29 (see 5.2.3.3.2.3) defines the pin assignments for the Mini SAS 4x cable plug connector.

See 5.2.4.2.1 for icon requirements for the Mini SAS 4x cable plug connector.

See 5.2.3.3.2.4 for keying requirements for the Mini SAS 4x cable plug connector.

#### **5.2.3.3.2.2 Mini SAS 4x receptacle connector**

The Mini SAS 4x receptacle connector is the fixed (receptacle) right angle connector defined in SFF-8088 with the 26 circuit size defined in SFF-8086.

A SAS 4x receptacle connector may be used by one or more SAS devices (e.g., one SAS device using physical links 0 and 3, another using physical link 1, and a third using physical link 2).

A SAS 4x receptacle connector shall be used by no more than one expander device at a time, and all physical links shall be used by the same expander port (i.e., all the expander phys shall have the same routing attribute (e.g., subtractive or table) (see 4.6.2)).

Figure 68 shows the Mini SAS 4x receptacle connector.

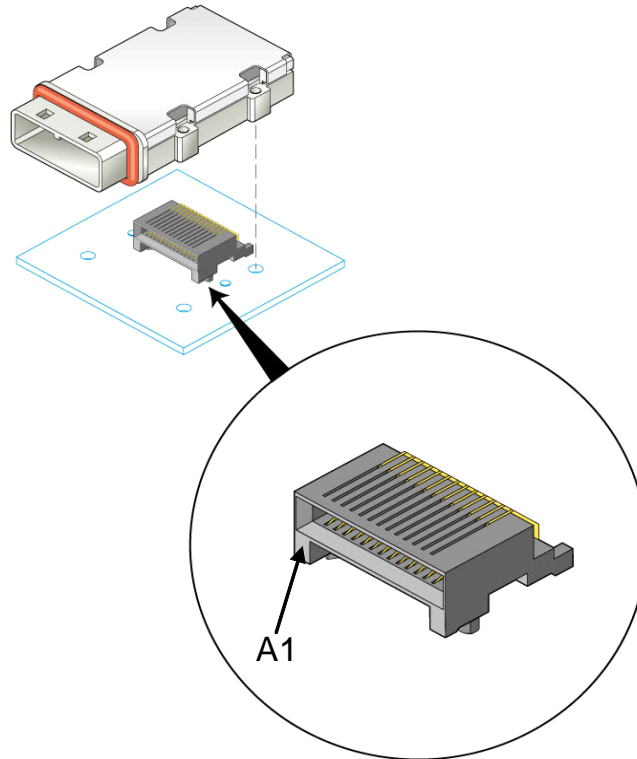

**Figure 68 — Mini SAS 4x receptacle connector**

Table 29 (see 5.2.3.3.2.3) defines the pin assignments for the Mini SAS 4x receptacle connector.

Based on what device is using the connector, the end device SAS icon (see figure M.2), enclosure out port SAS icon (see figure M.3), or enclosure in port SAS icon (see figure M.4) shall be placed on or near the Mini SAS 4x receptacle connector.

See 5.2.3.3.2.4 for keying requirements for the Mini SAS 4x receptacle connector.

### 5.2.3.3.2.3 Mini SAS 4x connector pin assignments

Table 29 defines the pin assignments for Mini SAS 4x cable plug connectors (see 5.2.3.3.2.1) and Mini SAS 4x receptacle connectors (see 5.2.3.3.2.2) for applications using one, two, three, or four of the physical links.

**Table 29 — Mini SAS 4x connector pin assignments and physical link usage**

Signal	Pin usage based on number of physical links supported by the cable assembly <sup>a</sup>			
	One	Two	Three	Four
Rx 0+	A2	A2	A2	A2
Rx 0-	A3	A3	A3	A3
Rx 1+	N/C	A5	A5	A5
Rx 1-	N/C	A6	A6	A6
Rx 2+	N/C	N/C	A8	A8
Rx 2-	N/C	N/C	A9	A9
Rx 3+	N/C	N/C	N/C	A11
Rx 3-	N/C	N/C	N/C	A12
Tx 0+	B2	B2	B2	B2
Tx 0-	B3	B3	B3	B3
Tx 1+	N/C	B5	B5	B5
Tx 1-	N/C	B6	B6	B6
Tx 2+	N/C	N/C	B8	B8
Tx 2-	N/C	N/C	B9	B9
Tx 3+	N/C	N/C	N/C	B11
Tx 3-	N/C	N/C	N/C	B12
SIGNAL GROUND	A1, A4, A7, A10, A13 B1, B4, B7, B10, B13			
CHASSIS GROUND	Housing			
<sup>a</sup> N/C = not connected				

SIGNAL GROUND shall not be connected to CHASSIS GROUND in the connector when used in a cable assembly.

### 5.2.3.3.2.4 Mini SAS 4x connector keying

The Mini SAS 4x receptacle connector (see 5.2.3.3.2.2) shall include keys to prevent attachment to a Mini SAS 4x cable plug connector (see 5.2.3.3.2.1) without matching key slots.

The Mini SAS 4x cable plug connector (see 5.2.3.3.2.1) shall include key slots to allow attachment to a Mini SAS 4x receptacle connector (see 5.2.3.3.2.2) with matching keys.

Table 30 defines the key slot positions used by Mini SAS 4x cable plug connectors.

**Table 30 — Mini SAS 4x cable plug connector key slot positions**

Use	Key slot positions
End that attaches to an end device or an enclosure out port	1, 3
End that attaches to an end device or an enclosure in port	3, 5

Table 31 defines the key positions used by Mini SAS 4x receptacle connectors.

**Table 31 — Mini SAS 4x receptacle connector key positions**

Use	Key position
Enclosure out port (see 4.6.2)	1
End device	3
Enclosure in port (see 4.6.2)	5

Figure 69 shows the keys on a Mini SAS 4x receptacle connector used by end devices.

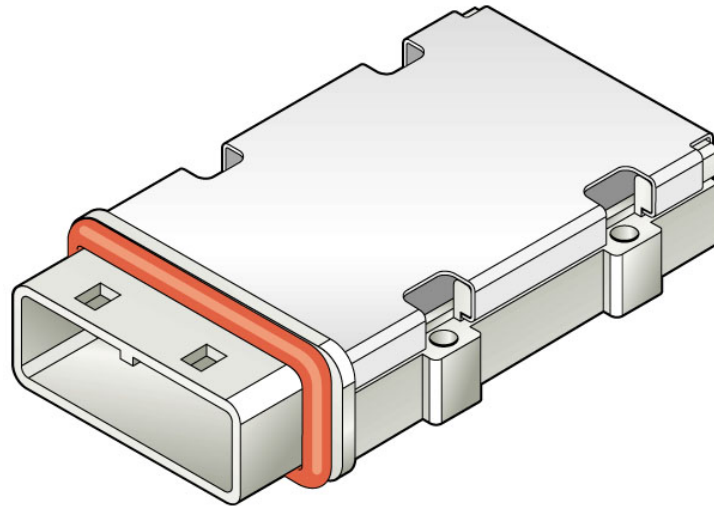

**Figure 69 — Mini SAS 4x receptacle connector - end device**

Figure 70 shows the keys on a Mini SAS 4x receptacle connector used by an enclosure out port.

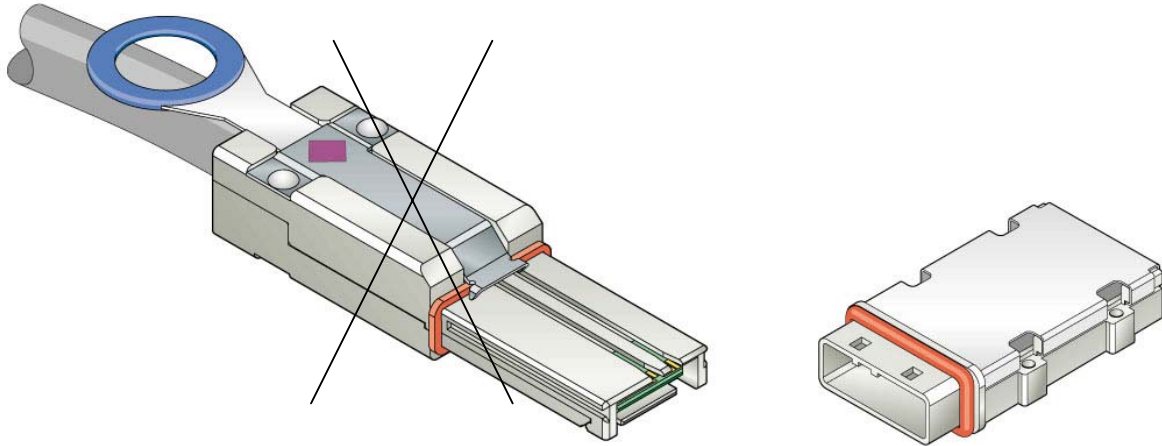

**Figure 70 — Mini SAS 4x receptacle connector - enclosure out port**

---

---

Editor's Note 1: awaiting updated figure without the cable plug

---

---

Figure 71 shows the keys on a Mini SAS 4x receptacle connector used by an enclosure in port.

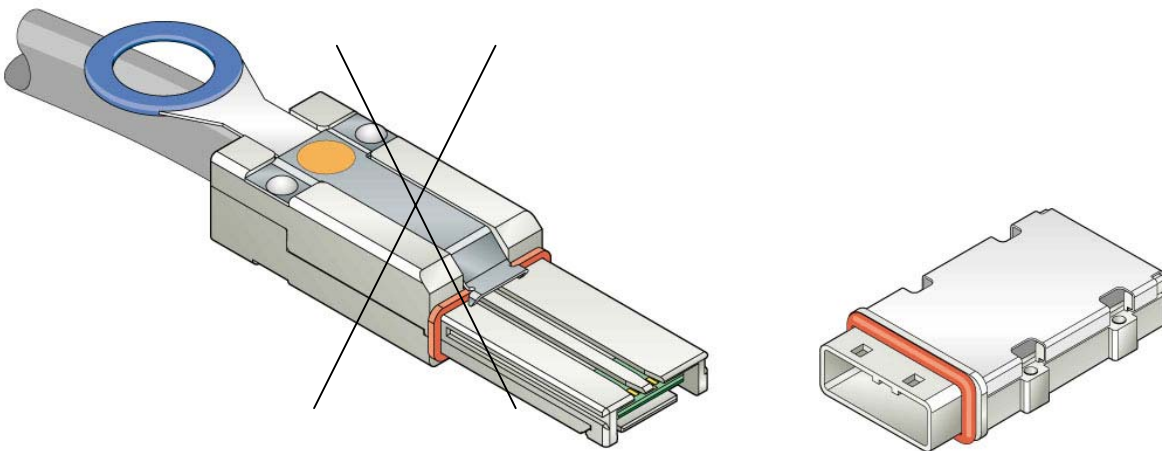

**Figure 71 — Mini SAS 4x receptacle connector - enclosure in port**

---

---

Editor's Note 2: awaiting updated figure without the cable plug

---

---

Figure 72 shows the keys on a Mini SAS 4x cable plug connector used to attach to an end device or an enclosure out port.

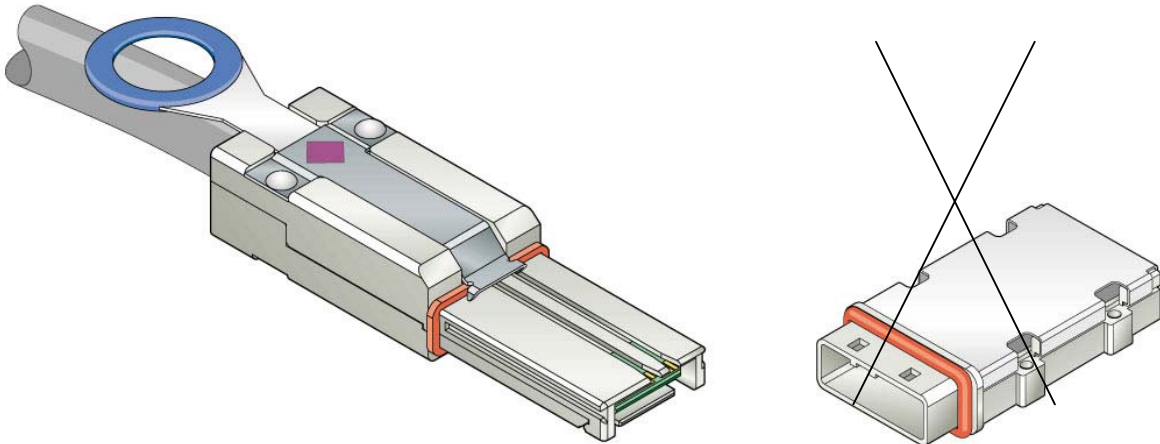

**Figure 72 — Mini SAS 4x cable plug connector - enclosure out port end**

---

Editor's Note 3: awaiting updated figure without the receptacle, and with the new correct circle (for out port) icon

---

Figure 73 shows the keys on a Mini SAS 4x cable plug connector used to attach to an end device or an enclosure in port.

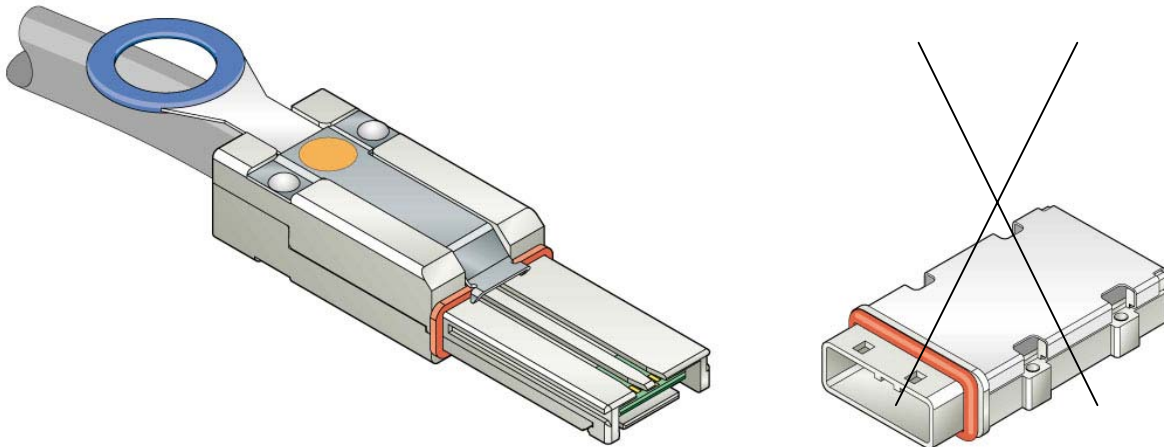

**Figure 73 — Mini SAS 4x cable plug connector - enclosure in port end**

---

Editor's Note 4: awaiting updated figure without the receptacle, and with the new correct diamond (for in port) icon

---



5.2.4 Cable assemblies

5.2.4.1 SAS internal cable assemblies

5.2.4.1.1 SAS Drive cable assemblies

There are two types of SAS Drive cable assemblies:

- a) Single-port SAS Drive cable assembly; and
- b) Dual-port SAS Drive cable assembly.

Both SAS Drive cable assemblies shall use:

- a) a SAS Drive cable receptacle connector (see 5.2.3.2.1.2) on the SAS target device end; and
- b) a SATA-style signal cable receptacle connector (see ATA/ATAPI-7 V3) on the SAS initiator device or expander device end.

The power and READY LED signal connection is vendor specific.

A SAS initiator device shall use a SATA-style host plug connector (see ATA/ATAPI-7 V3) for connection to a SAS Drive cable assembly. The signal assignment for the SAS initiator device or expander device with this connector shall be the same as that defined for a SATA host (see ATA/ATAPI-7 V3).

Figure 74 shows the Single-port SAS Drive cable assembly.

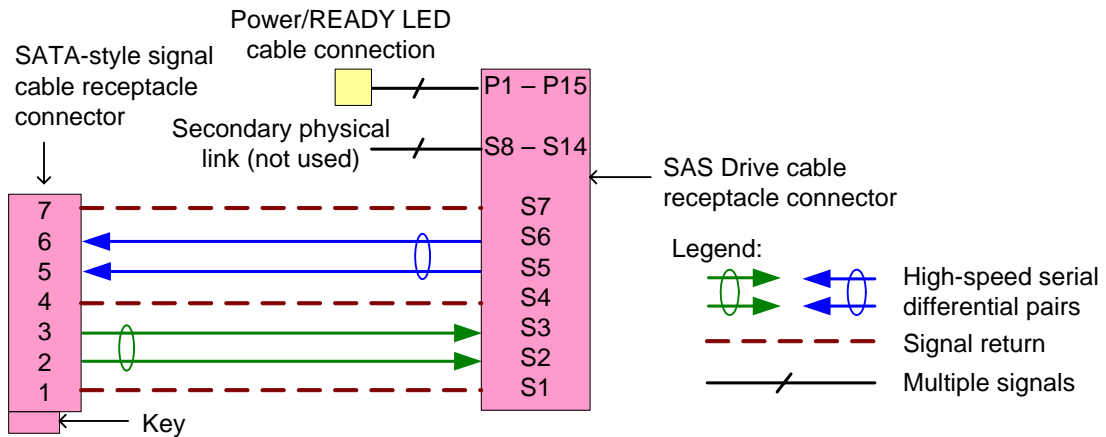
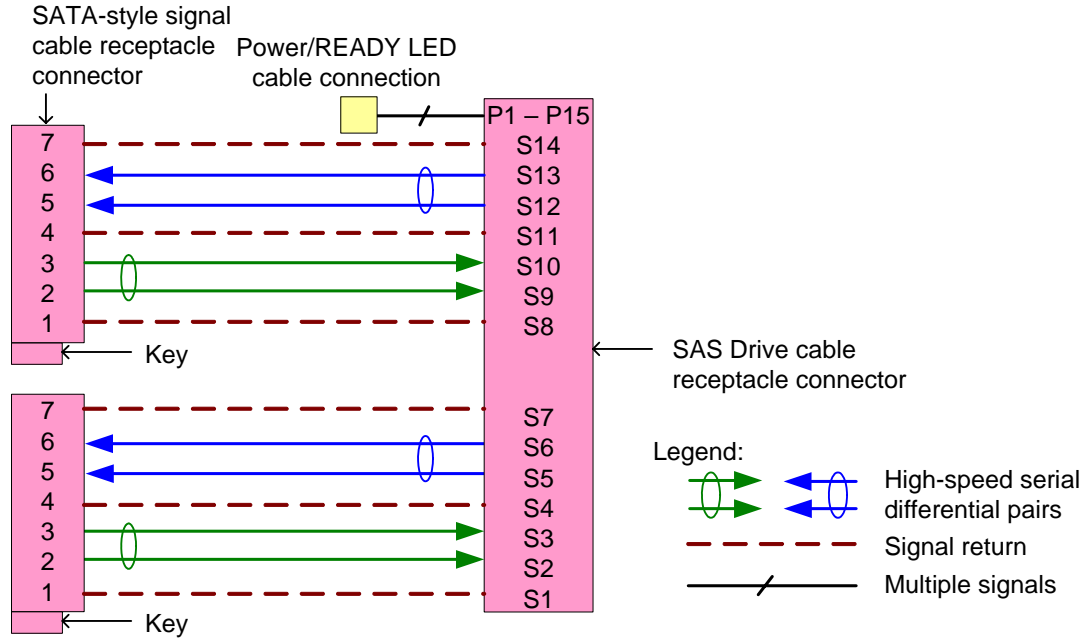

Figure 74 — Single-port SAS Drive cable assembly

Figure 75 shows the Dual-port SAS Drive cable assembly.



**Figure 75 — Dual-port SAS Drive cable assembly**

#### 5.2.4.1.2 SAS internal symmetric cable assemblies

##### 5.2.4.1.2.1 SAS internal symmetric cable assemblies overview

There are several types of SAS internal symmetric cable assemblies:

- SAS 4i cable receptacle connectors (see 5.2.3.2.2.1) on each end (see 5.2.4.1.2.2);
- Mini SAS 4i cable plug connectors (see 5.2.3.2.3.2) on each end (see 5.2.4.1.2.3); and
- a SAS 4i cable receptacle connector on one end and a Mini SAS 4i cable plug connector on the other end (see 5.2.4.1.2.4).

In a SAS internal symmetric cable assembly, the Tx signals on one end shall be connected to Rx signals on the other end (e.g., a Tx + of one connector shall connect to an Rx + of the other connector). SAS internal symmetric cable assemblies should be labeled to indicate how many physical links are included (e.g., 1X, 2X, 3X, and 4X on each connector's housing)

With the SAS 4i cable plug connector, the physical link number of the signal depends on the application (e.g., controller-to-controller applications and controller-to-backplane applications differ).

Although the SAS 4i cable receptacle connector and Mini SAS 4i cable plug connector always support four physical links:

- a SAS internal symmetric cable assembly using SAS 4i cable receptacle connectors may support one, two, three, or four physical links when used for controller-to-backplane applications;
- a SAS internal symmetric cable assembly using SAS 4i cable receptacle connectors shall support four physical links when used for controller-to-controller applications; and
- a SAS internal symmetric cable assembly using Mini SAS 4i cable plug connectors may support one, two, three, or four physical links for either controller-to-backplane or controller-to-controller applications.

5.2.4.1.2.2 SAS internal symmetric cable assembly - SAS 4i

Figure 76 shows the SAS internal symmetric cable assembly with SAS 4i cable receptacle connectors at each end.

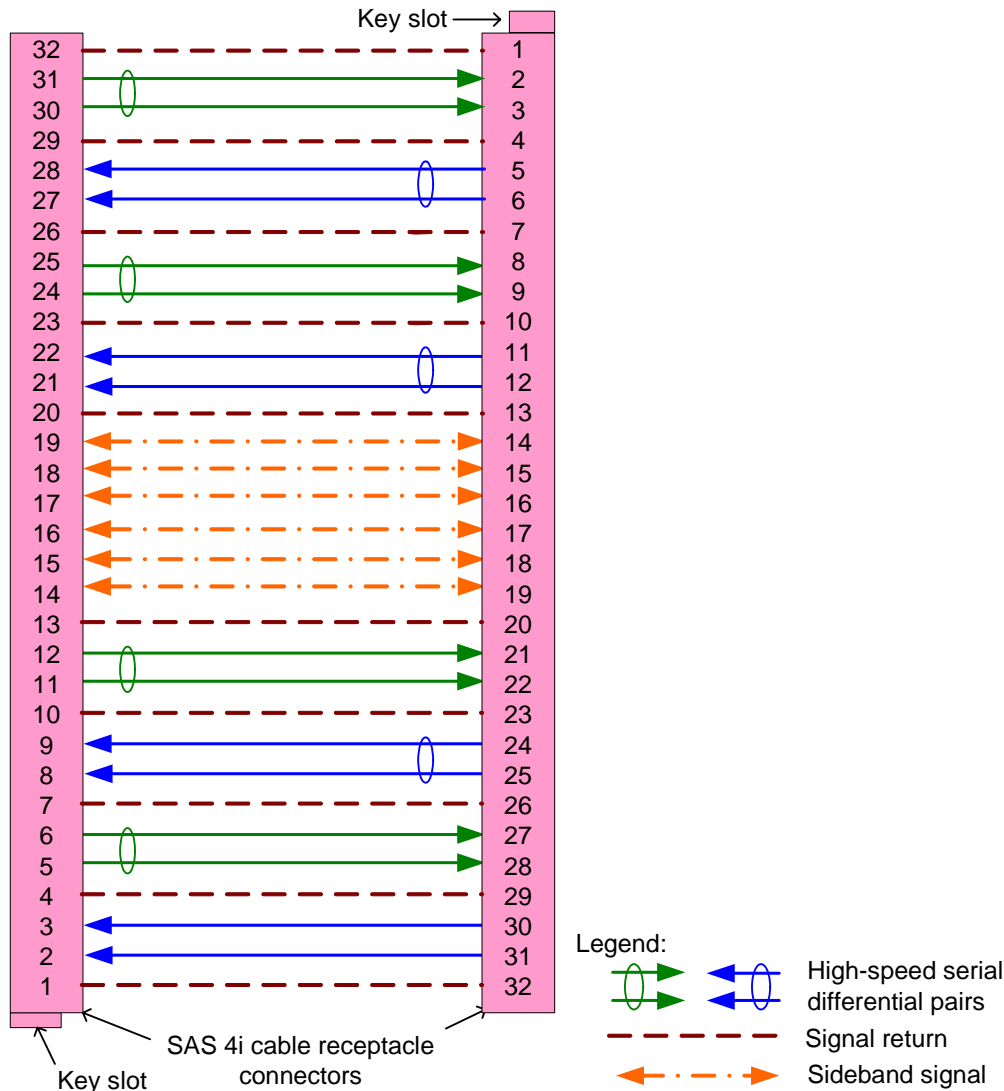

Figure 76 — SAS internal symmetric cable assembly - SAS 4i

In addition to the signal return connections shown in figure 76, the cable assembly may connect one or more of the signal returns together.

For controller-to-backplane applications, the cable assembly may support one to four physical links. SIDEBAND signals on the controller are attached to the corresponding SIDEBAND signals on the backplane (e.g., SIDEBAND0 of the controller is attached to SIDEBAND0 of the backplane).

For controller-to-controller applications, the cable assembly shall support all four physical links and the controllers should use all four physical links, because one controller's physical links 0 and 1 are attached the other controller's physical links 3 and 2, respectively. If both controllers use one or two physical links starting with physical links 0, communication is not possible. If both controllers use physical links 0, 1, and 2, then only communication over physical links 1 and 2 is possible. SIDEBAND signals on one controller are not attached to their corresponding SIDEBAND signals on the other controller (e.g., SIDEBAND0 of one controller is attached to SIDEBAND5 of the other controller).

5.2.4.1.2.3 SAS internal symmetric cable assembly - Mini SAS 4i

Figure 77 shows the SAS internal cable assembly with Mini SAS 4i cable plug connectors at each end.

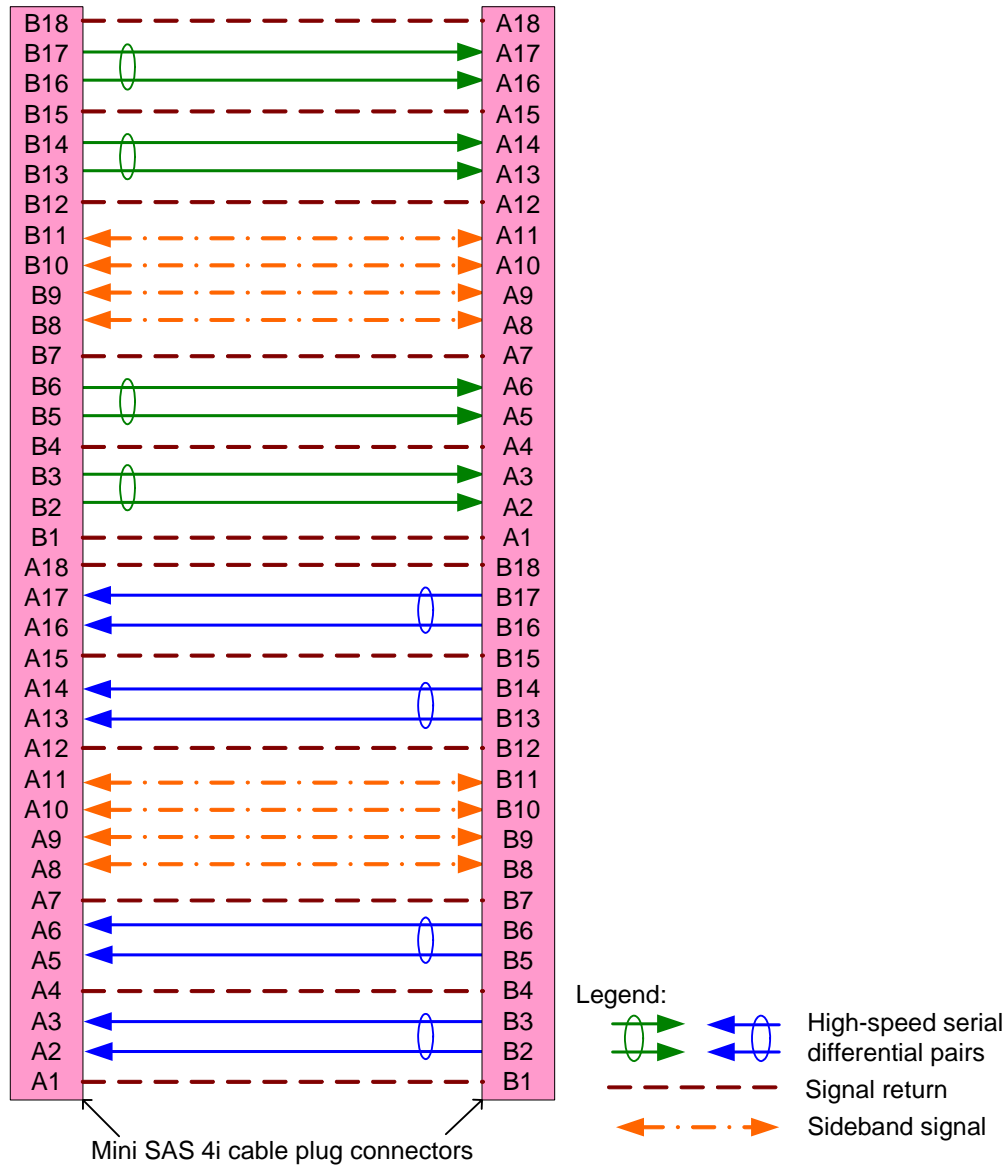

Figure 77 — SAS internal symmetric cable assembly - Mini SAS 4i

In addition to the signal return connections shown in figure 77, the cable assembly may connect one or more of the signal returns together.

The cable assembly may support one to four physical links.

For controller-to-backplane applications, SIDEBAND signals on the controller are attached to the corresponding SIDEBAND signals on the backplane (e.g., SIDEBAND0 of the controller is attached to SIDEBAND0 of the backplane).

For controller-to-controller applications, SIDEBAND signals on one controller are not attached to their corresponding SIDEBAND signals on the other controller (e.g., SIDEBAND0 of one controller is attached to SIDEBAND6 of the other controller).

5.2.4.1.2.4 SAS internal symmetric cable assembly - SAS 4i to Mini SAS 4i

Figure 78 shows the SAS internal symmetric cable assembly with a SAS 4i cable receptacle connector at one end and a Mini SAS 4i cable plug connector at the other end.

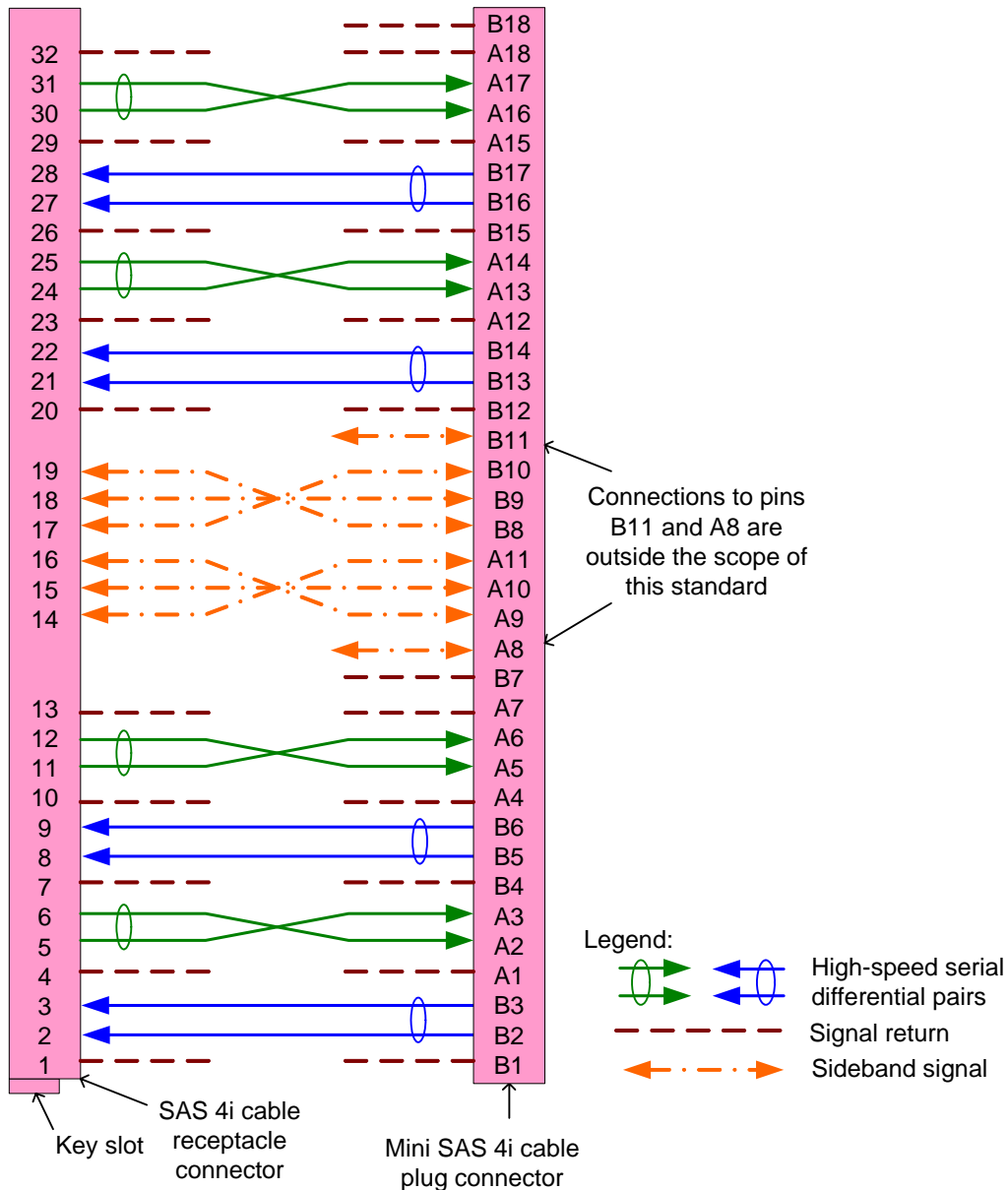

Figure 78 — SAS internal symmetric cable assembly - SAS 4i to Mini SAS 4i

The cable assembly shall connect each signal return on one end to at least one signal return on the other end. The cable assembly may connect one or more of the signal returns together.

SIDEBAND6 and SIDEBAND7 on the Mini SAS 4i cable plug connector are not attached to anything on the SAS 4i cable plug connector.

For controller-to-backplane applications with the SAS 4i cable receptacle connector on the controller end, the cable assembly may support one to four physical links. SIDEBAND signals on the controller are attached to the corresponding SIDEBAND signals on the backplane (e.g., SIDEBAND0 of the controller is attached to SIDEBAND0 of the backplane).

For controller-to-controller applications, the cable assembly may support one to four physical links. SIDEBAND signals on one controller are not attached to their corresponding SIDEBAND signals on the other controller (e.g., SIDEBAND0 of one controller is attached to SIDEBAND6 of the other controller).

For controller-to-backplane applications with the Mini SAS 4i cable receptacle connector on the controller end, the cable assembly shall support all four physical links and the controller should use all four physical links, because the controller's physical links 0, 1, 2, and 3 are attached to the backplane's physical links 3, 2, 1, and 0, respectively. If both controllers use one or two physical links starting with physical links 0, communication is not possible. If both controllers use physical links 0, 1, and 2, then only communication over physical links 1 and 2 is possible. SIDEBAND signals on the controller are attached to the corresponding SIDEBAND signals on the backplane (e.g., SIDEBAND0 of the controller is attached to SIDEBAND0 of the backplane).

#### **5.2.4.1.3 SAS internal fanout cable assemblies**

##### **5.2.4.1.3.1 SAS internal fanout cable assemblies overview**

There are several types of SAS internal fanout cable assemblies:

- a) SAS internal controller-based fanout cable assemblies (see 5.2.4.1.3.2) with:
  - A) a SAS 4i cable receptacle connector on one end (i.e., the controller end) and four SAS Drive cable receptacle connectors on the other end (i.e., the backplane end); and
  - B) a Mini SAS 4i cable plug connector on one end (i.e., the controller end) and four SAS Drive cable receptacle connectors on the other end (i.e., the backplane end);and
- b) SAS internal backplane-based fanout cable assemblies (see 5.2.4.1.3.3):
  - A) four SATA-style signal cable receptacle connectors on one end (i.e., the controller end) and a SAS 4i cable receptacle connector on the other end (i.e., the backplane end); and
  - B) four SATA-style signal cable receptacle connectors on one end (i.e., the controller end) and a Mini SAS 4i cable plug connector on the other end (i.e., the backplane end).

In a SAS internal fanout symmetric cable assembly, the Tx signals on one end shall be connected to Rx signals on the other end (e.g., a Tx + of one connector shall connect to an Rx + of the other connector).

5.2.4.1.3.2 SAS internal controller-based fanout cable assemblies

Figure 79 shows the SAS internal controller-based fanout cable assembly with a SAS 4i cable receptacle connector at the controller end.

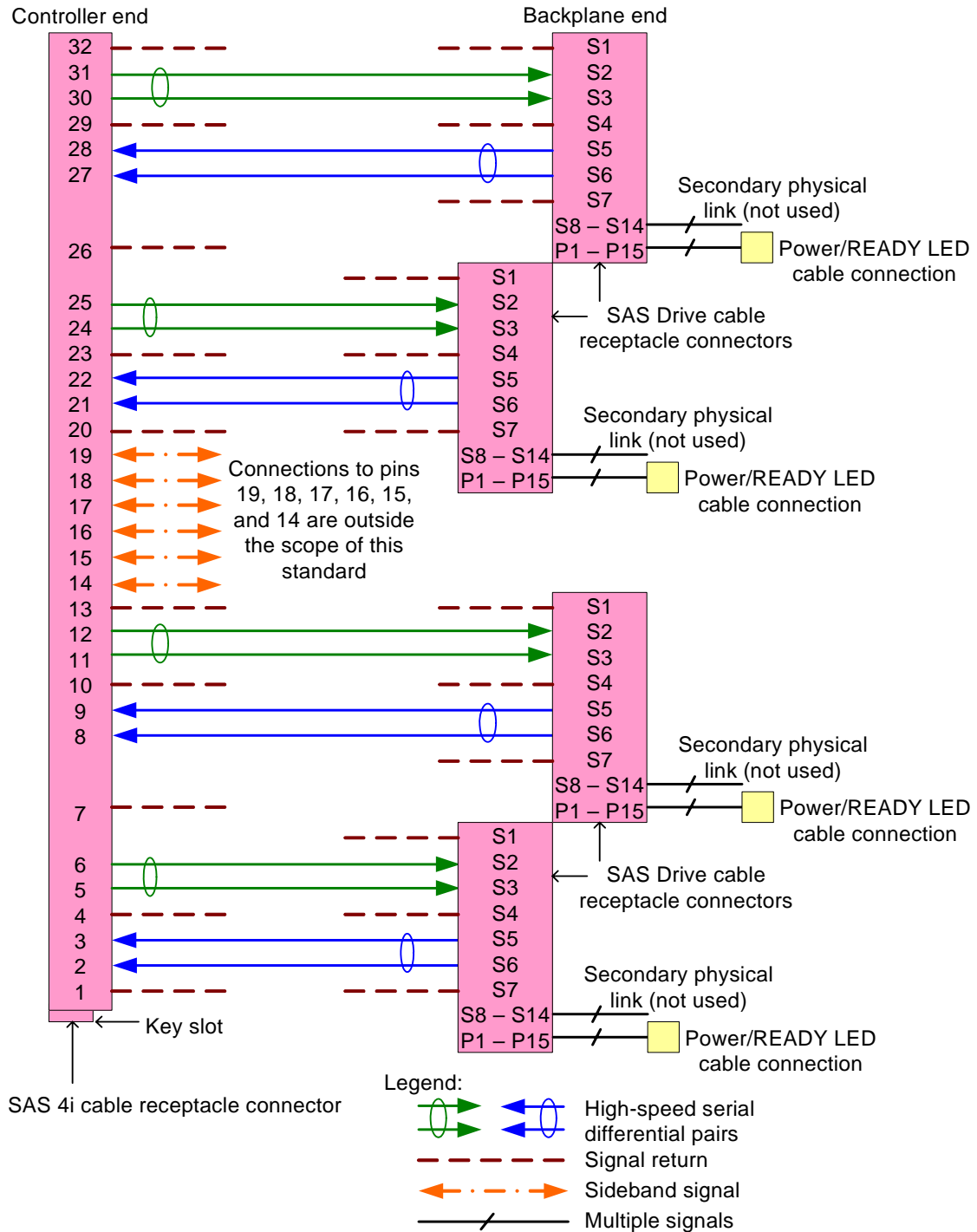

Figure 79 — SAS internal controller-based fanout cable assembly - SAS 4i

The cable assembly shown in figure 79 shall connect each signal return on one end to at least one signal return on the other end. The cable assembly may connect one or more of the signal returns together.

Figure 80 shows the SAS internal controller-based fanout cable assembly with a Mini SAS 4i cable plug connector at the controller end.

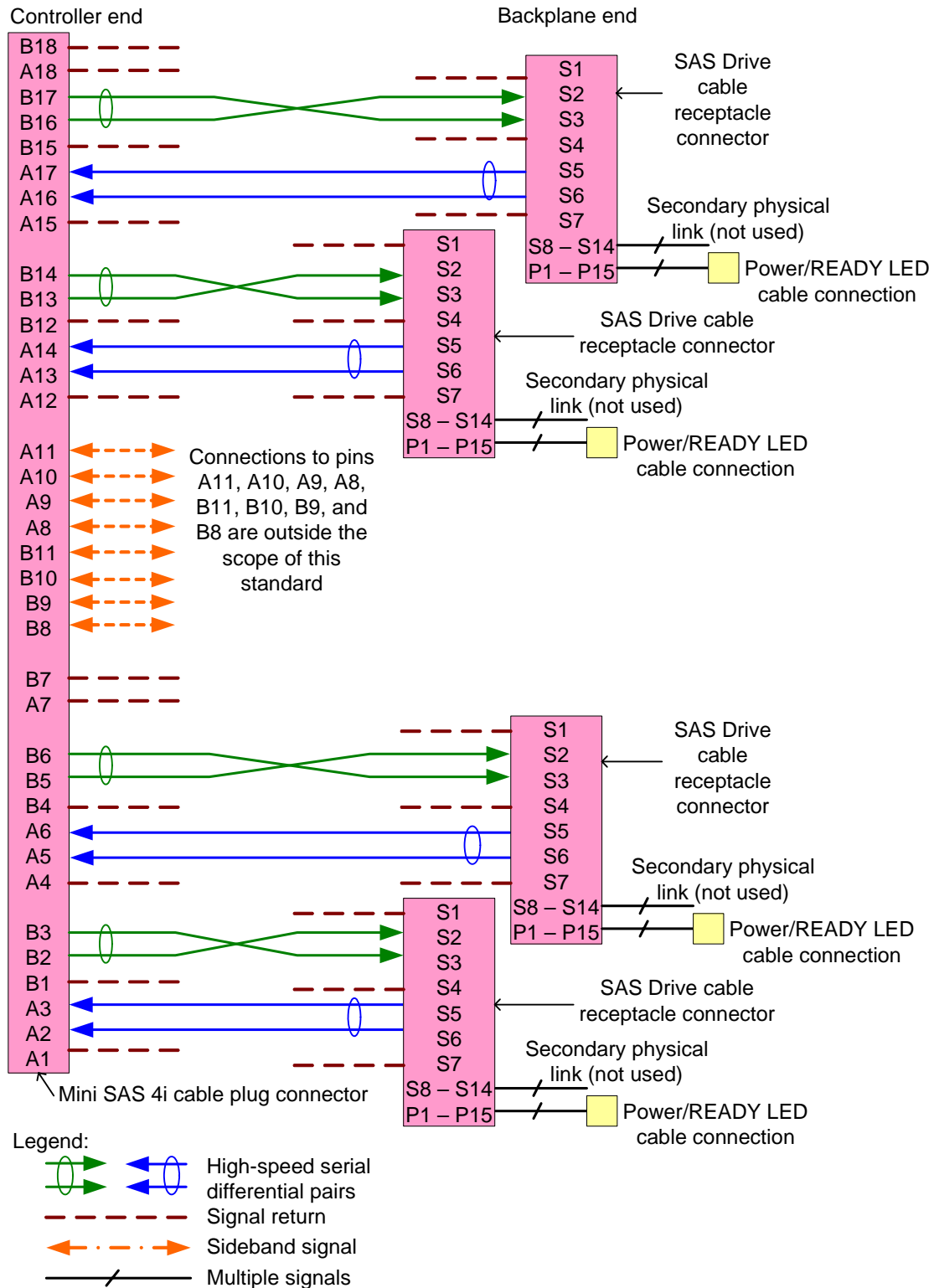

Figure 80 — SAS internal controller-based fanout cable assembly - Mini SAS 4i

The cable assembly shown in figure 80 shall connect each signal return on one end to at least one signal return on the other end. The cable assembly may connect one or more of the signal returns together.



5.2.4.1.3.3 SAS internal backplane-based fanout cable assemblies

Figure 81 shows the SAS internal backplane-based fanout cable assembly with the SAS 4i cable receptacle connector.

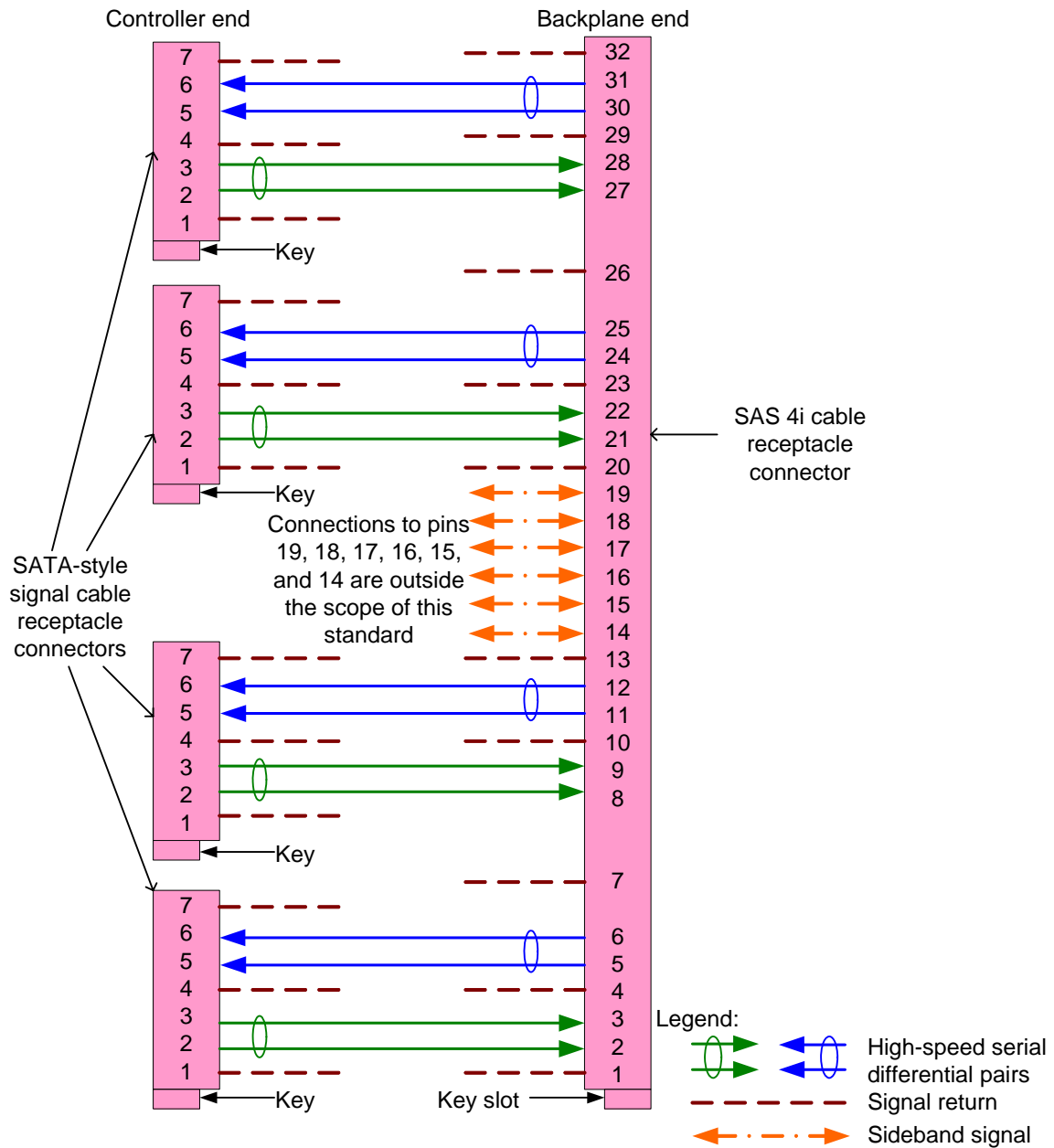
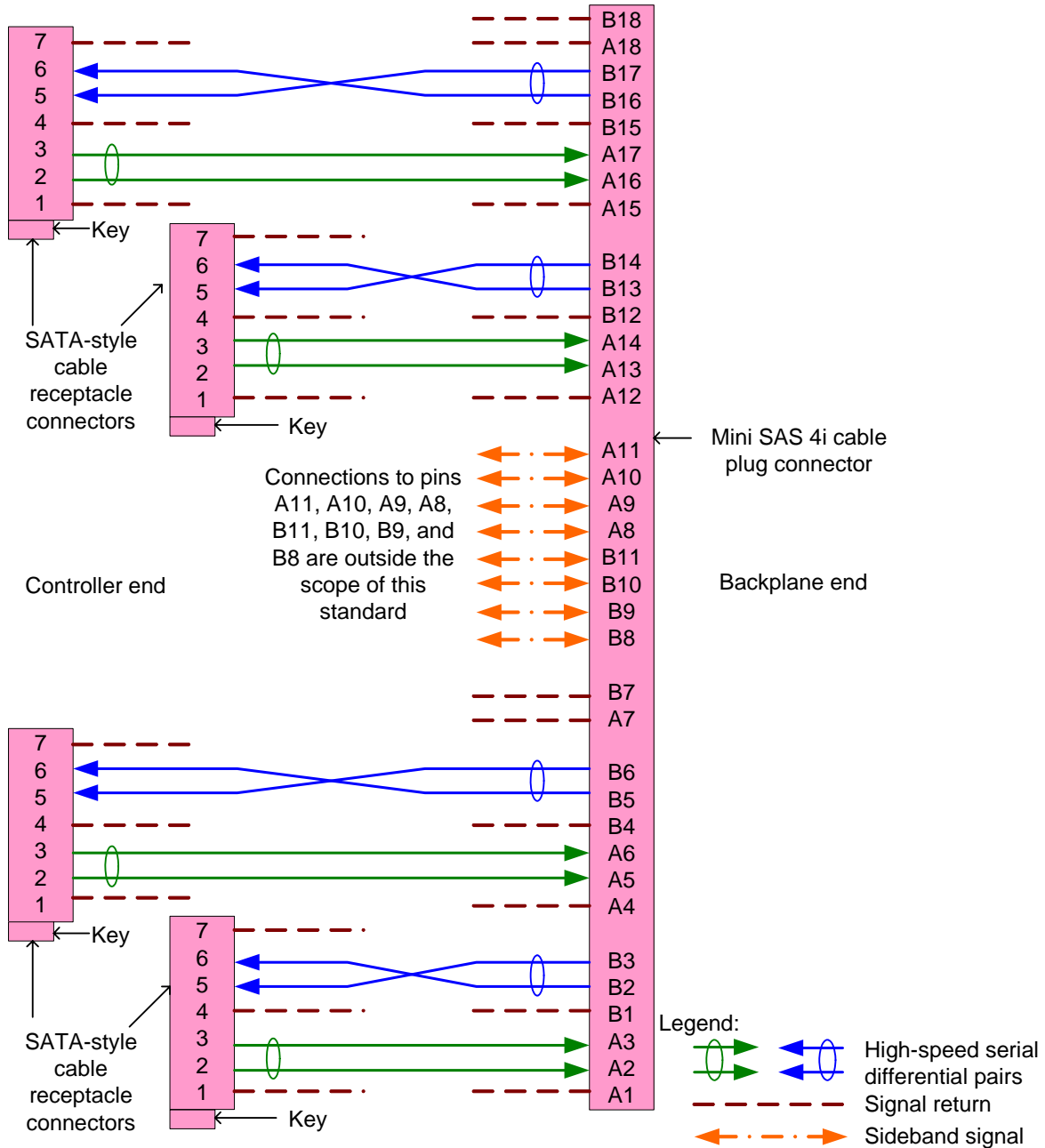

Figure 81 — SAS internal backplane-based fanout cable assembly - SAS 4i

The cable assembly shown in figure 81 shall connect each signal return on one end to at least one signal return on the other end. The cable assembly may connect one or more of the signal returns together.

Figure 82 shows the SAS internal backplane-based fanout cable assembly with the Mini SAS 4i cable receptacle connector.



**Figure 82 — SAS internal backplane-based fanout cable assembly - Mini SAS 4i**

The cable assembly shown in figure 82 shall connect each signal return on one end to at least one signal return on the other end. The cable assembly may connect one or more of the signal returns together.

**5.2.4.2 SAS external cable assemblies**

**5.2.4.2.1 SAS external cable assemblies overview**

There are several types of SAS external cable assemblies:

- a) SAS 4x cable plug connector (see 5.2.3.3.1.1) at each end (see 5.2.4.2.2);
- b) Mini SAS 4x cable plug connector (see 5.2.3.3.2.1) at each end (see 5.2.4.2.3); and

- c) SAS 4x cable plug connector at one end and Mini SAS 4x cable plug connector at the other end (see 5.2.4.2.4).

SAS external cable assemblies do not include power or the READY LED signal.

Although the connector always supports four physical links, a SAS external cable assembly may support one, two, three, or four physical links. SAS external cable assemblies should be labeled to indicate how many physical links are included (e.g., 1X, 2X, 3X, and 4X on each connector's housing)

The Tx signals on one end shall be connected to the corresponding Rx signals of the other end (e.g., Tx 0+ of one connector shall be connected to Rx 0+ of the other connector).

Signal returns shall not be connected to CHASSIS GROUND in the cable assembly.

The icon for the end of a cable assembly that attaches to end devices or an enclosure out port (see figure M.5) should be placed on or near one end of the cable assembly if using a SAS 4x connector and shall be placed on the connector if using a Mini SAS 4x connector. The icon for the end of a cable assembly that attaches to end devices or an enclosure in port (see figure M.6) should be placed on or near the other end of the cable assembly if using a SAS 4x connector and shall be placed on the connector if using a Mini SAS 4x connector.

---

Editor's Note 5: Since the icons are required, they need to move to a normative annex or move into the main body

---

### 5.2.4.2.2 SAS external cable assembly - SAS 4x

Figure 83 shows the SAS external cable assembly with SAS 4x cable plug connectors at each end.

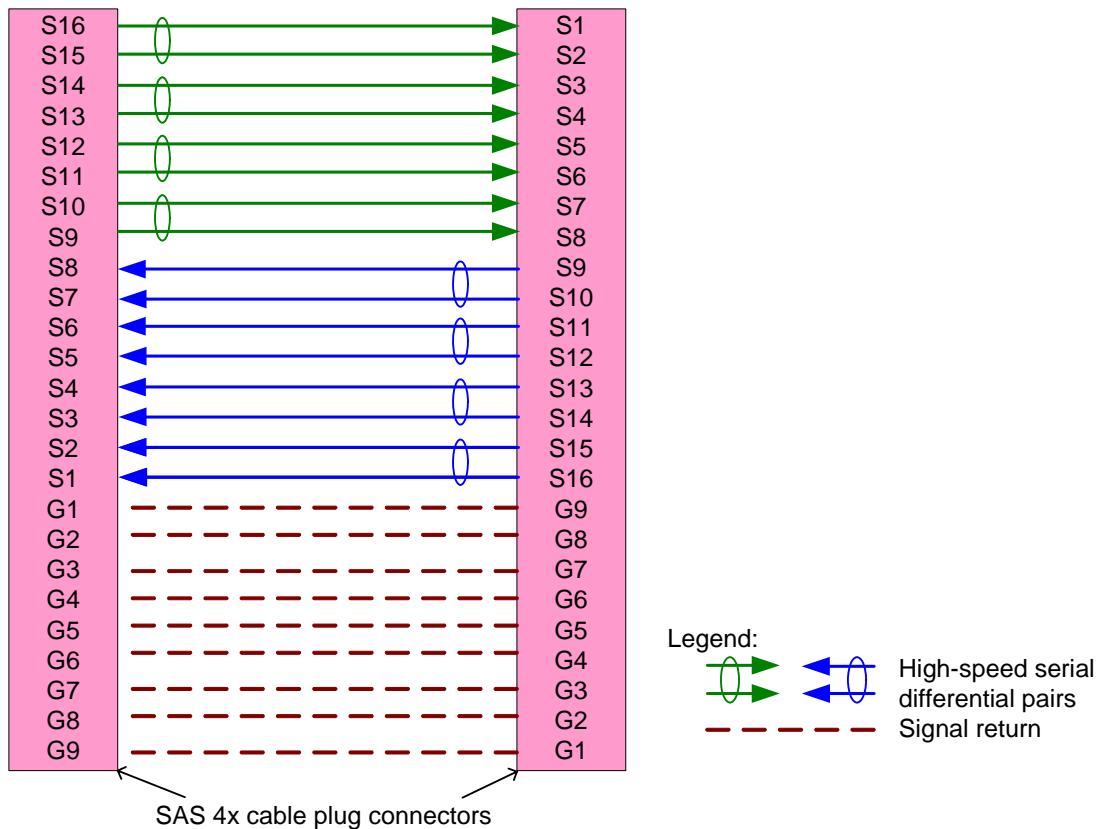

Figure 83 — SAS external cable assembly - SAS 4x

In addition to the signal return connections shown in figure 83, the cable assembly may connect one or more of the signal returns together.

5.2.4.2.3 SAS external cable assembly - Mini SAS 4x

Figure 84 shows the SAS external cable assembly with Mini SAS 4x cable plug connectors at each end.

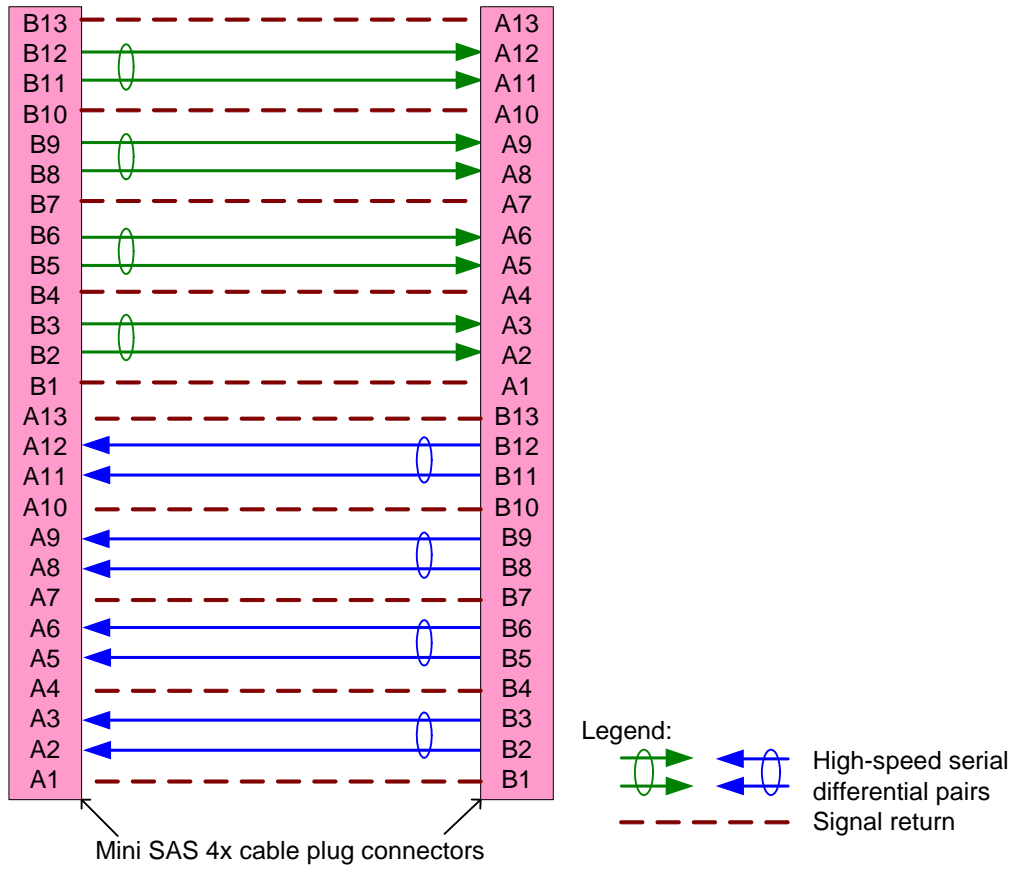

Figure 84 — SAS external cable assembly - Mini SAS 4x

In addition to the signal return connections shown in figure 84, the cable assembly may connect one or more of the signal returns together.

5.2.4.2.4 SAS external cable assembly - SAS 4x to Mini SAS 4x

Figure 85 shows the SAS external cable assembly with a SAS 4x cable plug connector at one end and a Mini SAS 4x cable plug connector at the other end.

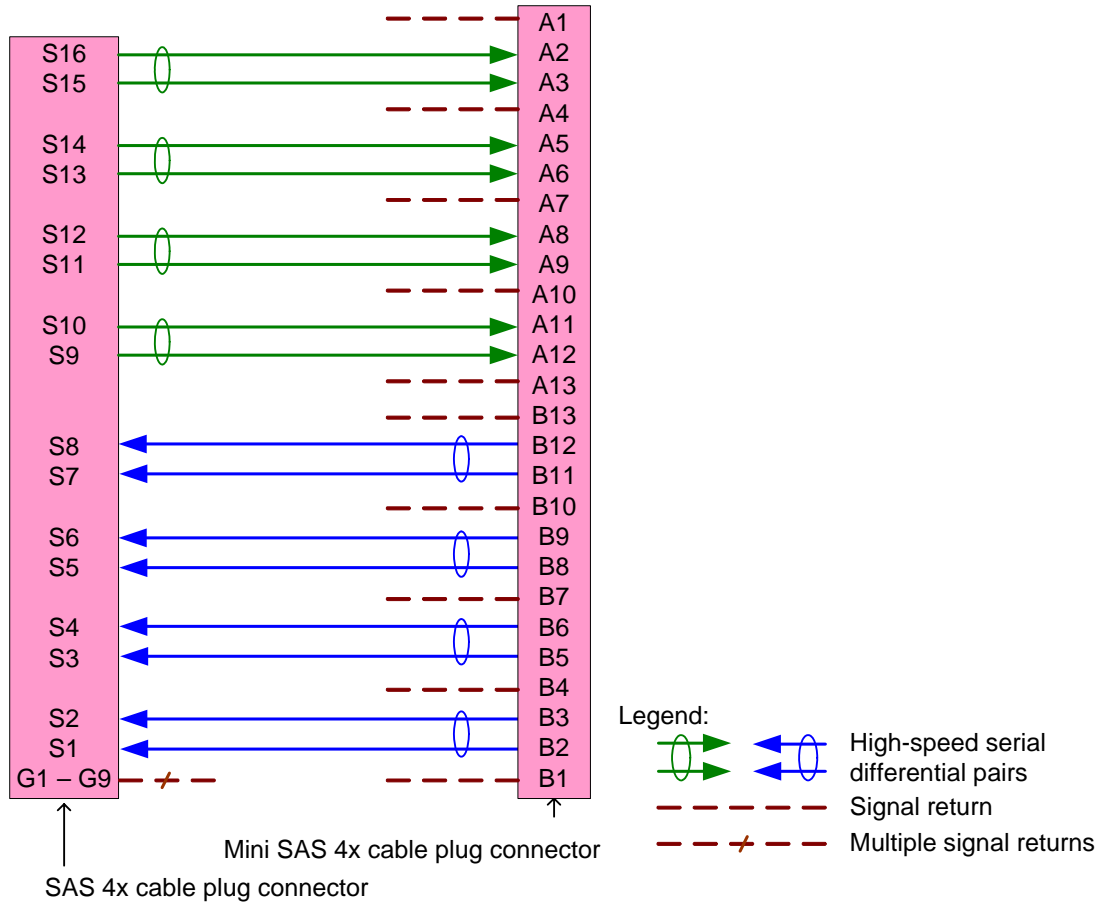

Figure 85 — SAS external cable assembly - SAS 4x to Mini SAS 4x

The cable assembly shown in figure 85 shall connect each signal return on one end to at least one signal return on the other end. The cable assembly may connect one or more of the signal returns together.

5.2.4.2.5 SAS external cable assembly with Mini SAS 4x connectors - standard key slots

Figure 86 shows a SAS external cable assembly with:

- a) a Mini SAS 4x cable plug connector at one end with key slots permitting attachment to end devices or an enclosure out port. The SAS external cable assembly shall include the SAS icon described in figure M.5 at this end (see M.2.3); and
- b) a Mini SAS 4x cable plug connector at the other end with key slots permitting attachment to end devices or an enclosure in port. The SAS external cable assembly shall include the SAS icon described in figure M.6 at this end (see M.2.3).

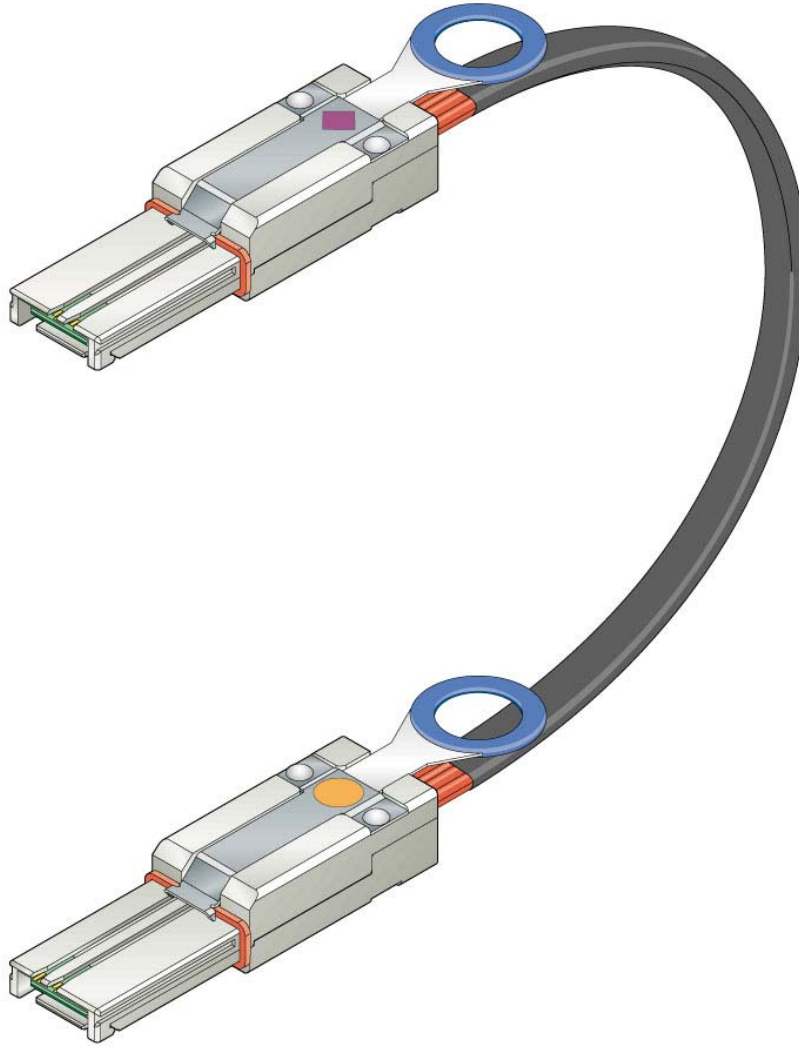

**Figure 86 — SAS external cable assembly with Mini SAS 4x cable plug connectors**

---

---

[Editor's Note 6: update with connectors with correct new icons](#)

---

---

### 5.2.5 Backplanes

SAS backplane designs should follow the recommendations in SFF-8460.