

To: T10 Technical Committee  
From: Barry Olawsky, HP ([barry.olawsky@hp.com](mailto:barry.olawsky@hp.com)) and  
Rob Elliott, HP ([elliott@hp.com](mailto:elliott@hp.com))  
Date: 26 January 2004  
Subject: T10/04-337r3 SAS-1.1 TCTF Editorial Changes

### **Revision History**

Revision 0 (13 October 2004) first revision  
Revision 1 (8 November 2004)  
Revision 2 (2 December 2004)  
Revision 3 (26 January 2004) Minor Text Edits

### **Related Documents**

sas1r06 - Serial Attached SCSI 1.1 revision 6  
04-370 SAS-1.1 Merge IT and IR with XT and XR  
t11/04-604 Compliance Interconnect Specification Methodology

### **Overview**

The descriptions of the TCTF are confusing.

The normative requirement about minimum ISI loss contained only in figures labeled “examples” is moved into the main set of S21 equations.

It is explicitly stated that S11, S22, and S12 are not specified, and that phases for all the scattering parameters are not specified. This is a placeholder for possibly adding those in the future (e.g. SAS-2).

Expanded the definition of scattering parameters and made S21 always S21(f).

The term “TCTF test load” is used throughout, replacing a hodgepodge of that term and “compliance interconnect”.

The S21 equations and introductory text is rephrased so  $\leq$  can be used. They are now phrased as describing the S21 of a (valid) TCTF test load. There are many possible TCTF test loads - any that fit in the  $\leq$  region. The graphs are shaded reflecting this.

Text added to zero-length test load description mentioning that the transmitter compliance point signal characteristics must be met there. That rule is already stated in 5.3.4. Added text next to the probe points in the test load figures showing which signal characteristics are tested there.

Change confusing “expander transmitter” wording in AC coupling text with reference to XT compliance point. It’s not just expanders; an initiator supporting attachment to SATA drives (which might not have AC coupled receivers) are supposed to follow the same rule. Changed other two sentences to CT (inter-enclosure) and IT (intra-enclosure).

To eliminate inappropriate compliance channel designs, added reference to electrical parameters table (for example, nominal impedance).

Additional comments recommended removal of definition of all four s-parameter to minimize possible confusion by the reader. Applicable portions were retained.

Added note to target ideal (nominal impedance) media characteristics.

Replaced AC coupling caps with DC blocks if coupling required.

Added note to clarify “Probe point” references in test load schematic diagrams.

Since 04-370 addresses compliance point definitions, changes in that proposal shall take priority where appropriate.

Changed “NOTE” reference to where. Deleted quotes around “probe points” phrase. Added specific callout to figures 51 and 52.

### **Suggested Changes**

### 5.3.11 Transmitter characteristics

~~For all inter-enclosure TxRx connections At CT, the transmitter shall be A.C. coupled to the interconnect through a transmission network.~~

~~For intra-enclosure TxRx connections the expander transmitter At XT, shall be A.C. coupled to the interconnect through a transmission network.~~

~~Other transmitters At IT, the transmitter may be A.C. or D.C. coupled.~~

~~A combination of a zero-length test load and the transmitter compliance transfer function (TCTF) test load methodology is used for the specification of the inter-enclosure and intra-enclosure transmitter characteristics. This methodology specifies the transmitter signal at the as measured at specified test points on ~~the required specified~~ test loads. Transmitters may or may not incorporate pre-emphasis or other forms of compensation. The transmitter shall use the same settings (e.g., pre-emphasis, and voltage swing) with both the zero-length test load and the TCTF test load. The ~~signal specifications at signal characteristic requirements for the corresponding receiver compliance point (i.e., IR, CR, and or XR)~~ shall be met ~~under each of these loading conditions~~ with each of these test loads. The TCTF test load shall meet the media requirements outlined in table 30. The nominal impedance shall be the target impedance.~~

~~The TCTF is the mathematical statement of the limiting transfer function through which the transmitter shall be capable of producing acceptable signals as defined by a receive mask. The transmission magnitude response of the TCTF for IT and XT is given by the following equation for 3,0 Gbps:~~

~~The TCTF test load is characterized by scattering parameters (i.e., s parameters) describing the reflection (i.e., scattering) and transmission coefficients between incident and reflected waves:~~

- ~~a)  $S_{11}(f)$ : input reflection coefficient;~~
- ~~b)  $S_{12}(f)$ : reverse transmission coefficient (i.e., reverse transmission gain);~~
- ~~c)  $S_{21}(f)$ : forward transmission coefficient (i.e., forward transmission gain); and~~
- ~~d)  $S_{22}(f)$ : output reflection coefficient.~~

~~The  $S_{21}(f)$  Each s-parameter is a complex number and is characterized with magnitude (expressed in dB) and phase components:~~

~~NOTE:, where dB is the logarithmic ratio of two signal amplitudes:~~

$$\text{db} = 20 \log (V_1 / V_2)$$

~~$S_{11}(f)$ ,  $S_{12}(f)$  and  $S_{22}(f)$  of the TCTF test load are not specified by this standard. The phase of  $S_{21}(f)$  of the TCTF test load is not specified by this standard.~~

~~The TCTF test load used for testing a 3,0 Gbps transmitter at IT and XT shall comply with the following equations for the magnitude of  $S_{21}(f)$  (denoted as  $|S_{21}(f)|$ ):~~

~~For 50 MHz < f < 3,0 GHz:~~

$$\text{ ~~} |S_{21}(f)| \text{ of TCTF test load } \leq -20 \times \log_{10}(e) \times ((6,5 \times 10^{-6} \times f^{0,5}) + (2,0 \times 10^{-10} \times f) + (3,3 \times 10^{-20} \times f^2)) \text{ dB}~~$$

~~and for 3,0 GHz < f < 5,0 GHz:~~

$$\text{ ~~} |S_{21}(f)| \text{ of TCTF test load } \leq -10,884 \text{ dB}~~$$

~~and, specifying a minimum ISI loss:~~

$$\text{ ~~} (|S_{21}(f = 300 \text{ MHz})| - |S_{21}(f = 1\,500 \text{ MHz})|) \text{ of TCTF test load } > 3,9 \text{ dB}~~$$

~~where:~~

~~f is the frequency of the measurement in hertz.~~

~~The transmission magnitude response of the TCTF for CT is given by the following equation for 3,0 Gbps:~~

The TCTF test load used for testing a 3,0 Gbps transmitter at CT shall comply with the following equations for the magnitude of  $S_{21}(f)$  (denoted as  $|S_{21}(f)|$ ):

For 50 MHz < f < 3,0 GHz:

$$|S_{21}(f)| \text{ of TCTF test load } \leq -20 \times \log_{10}(e) \times ((1,7 \times 10^{-5} \times f^{0,5}) + (1,0 \times 10^{-10} \times f)) \text{ dB}$$

and for 3,0 GHz < f < 5,0 GHz:

$$|S_{21}(f)| \text{ of TCTF test load } \leq -10,694 \text{ dB}$$

and, specifying a minimum ISI loss:

$$\underline{|S_{21}(f = 300 \text{ MHz})| - |S_{21}(f = 1\,500 \text{ MHz})|} \text{ of TCTF test load } > 3,9 \text{ dB}$$

where:

f is the signal frequency in hertz.

~~The transmission magnitude response of the TCTF for IT and XT is given by the following equation for 1,5 Gbps:~~

The TCTF test load used for testing a 1,5 Gbps transmitter at IT and XT shall comply with the following equations for the magnitude of  $S_{21}(f)$  (denoted as  $|S_{21}(f)|$ ):

For 50 MHz < f < 1,5 GHz:

$$|S_{21}(f)| \text{ of TCTF test load } \leq -20 \times \log_{10}(e) \times ((6,5 \times 10^{-6} \times f^{0,5}) + (2,0 \times 10^{-10} \times f) + (3,3 \times 10^{-20} \times f^2)) \text{ dB}$$

and for 1,5 GHz < f < 5,0 GHz:

$$|S_{21}(f)| \text{ of TCTF test load } \leq -5,437 \text{ dB}$$

and, specifying a minimum ISI loss:

$$\underline{|S_{21}(f = 300 \text{ MHz})| - |S_{21}(f = 1\,500 \text{ MHz})|} \text{ of TCTF test load } > 2,0 \text{ dB}$$

where:

f is the signal frequency in hertz.

~~The transmission magnitude response of the TCTF for CT is given by the following equations for 1,5 Gbps:~~

The TCTF test load used for testing a 1,5 Gbps transmitter at CT shall comply with the following equations for the magnitude of  $S_{21}(f)$  (denoted as  $|S_{21}(f)|$ ):

For 50 MHz < f < 1,5 GHz:

$$|S_{21}(f)| \text{ of TCTF test load } \leq -20 \times \log_{10}(e) \times ((1,7 \times 10^{-5} \times f^{0,5}) + (1,0 \times 10^{-10} \times f)) \text{ dB}$$

and for 1,5 GHz < f < 5,0 GHz:

$$|S_{21}(f)| \text{ of TCTF test load } \leq -7,022 \text{ dB}$$

and, specifying a minimum ISI loss:

$$\underline{(|S_{21}(f = 300 \text{ MHz})| - |S_{21}(f = 1\,500 \text{ MHz})|) \text{ of TCTF test load} > 2.0 \text{ dB}}$$

where:

f is the signal frequency in hertz.

~~The TCTF is used to specify the requirements on transmitters that may or may not incorporate pre-emphasis or other forms of compensation. A compliance interconnect is any physical interconnect with loss equal to or greater than that of the TCTF at the above frequencies that also meets the ISI loss requirements shown in figure 53 and figure 54.~~

Compliance with the TCTF test load requirement shall be determined by measuring the signal produced by the transmitter through a physical ~~compliance interconnect~~ TCTF test load attached to the transmitter compliance point (i.e., IT, CT, or XT) as shown in figure 51.

Compliance with the zero-length test load requirement shall be determined by ~~measurement made across measuring the signal produced by the transmitter through~~ a load equivalent to the zero-length load attached to the transmitter compliance point (i.e., IT, CT, or XT) as shown in figure 52.

~~For the zero-length test load, the transmitter shall deliver a signal compliant with the signal characteristics specified for the transmitter compliance point (see table 29) being tested.~~

~~For both the zero-length test load and the TCTF test load cases, the transmitter shall deliver the output voltages and timing listed in a signal compliant with the signal characteristics specified for the receiver compliance point (see table 30) corresponding to the transmitter compliance point being tested (i.e., IR for testing IT, CR for testing CT, and XR for testing XT), at the designated compliance points. The default mask shall be CR for inter-cabinet TxRx connections and IR for intra-cabinet TxRx connections. The eye masks are shown described in 5.3.3.~~

Figure 51 shows the ~~compliance interconnect~~ TCTF test load. Physical positions are denoted as 'probe points' in several of the figures 51 and 52 in this clause. Probe points identify the position in the testing procedures where the signal properties are measured but do not imply that physical probing is used for the measurement. Physical probing may be disruptive to the signals and should not be used unless verified to be non-disruptive.

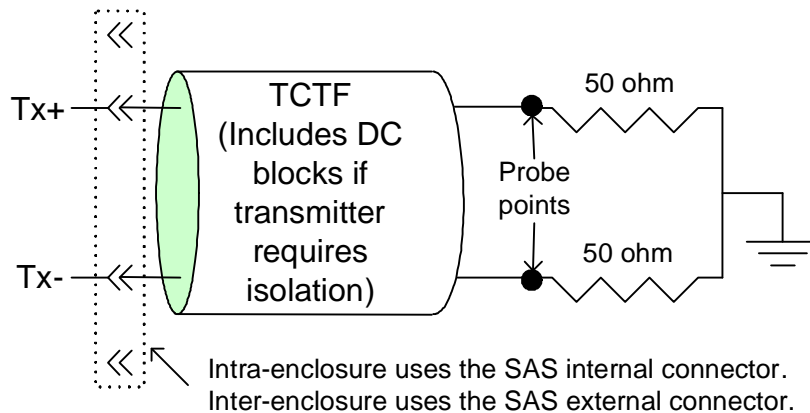

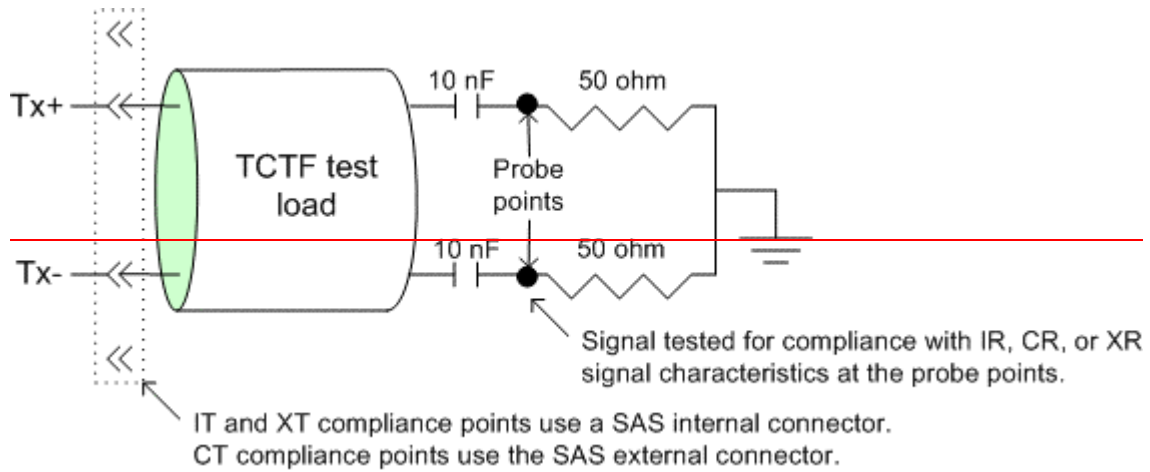

**Figure 51 — Compliance interconnect-TCTF test load**

Figure 52 shows the zero-length test load.

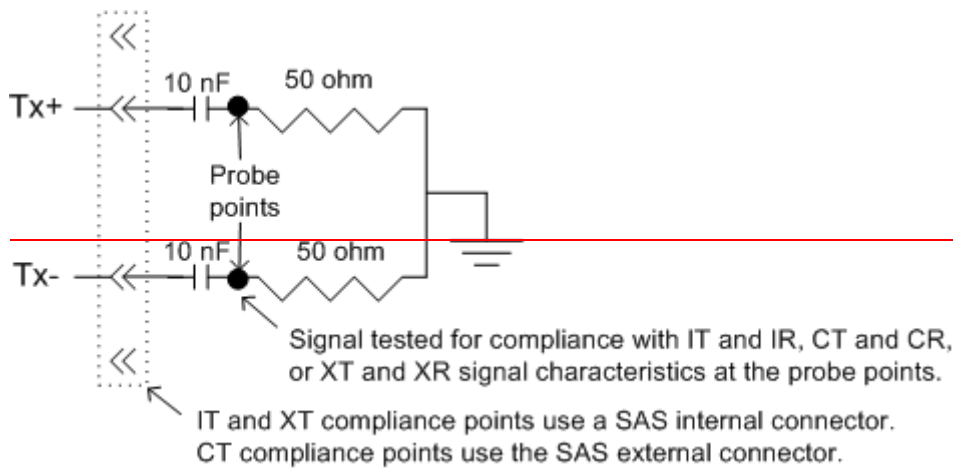
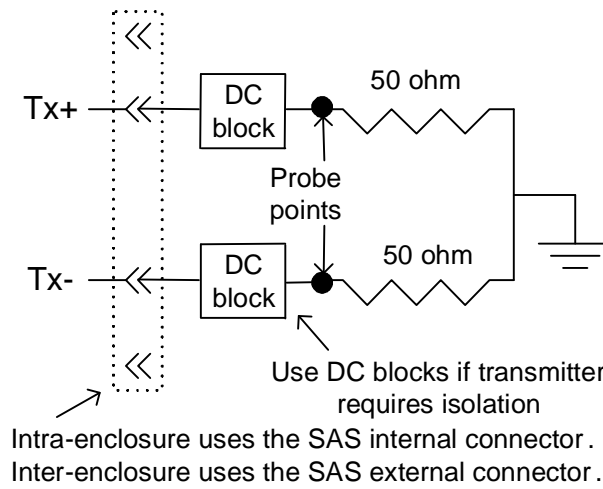

**Figure 52 — Zero-length test load**

Figure 53 shows an ISI loss example the allowable  $|S_{21}(f)|$  and minimum ISI loss of a TCTF test load and the  $|S_{21}(f)|$  of a sample TCTF test load at 3,0 Gbps.

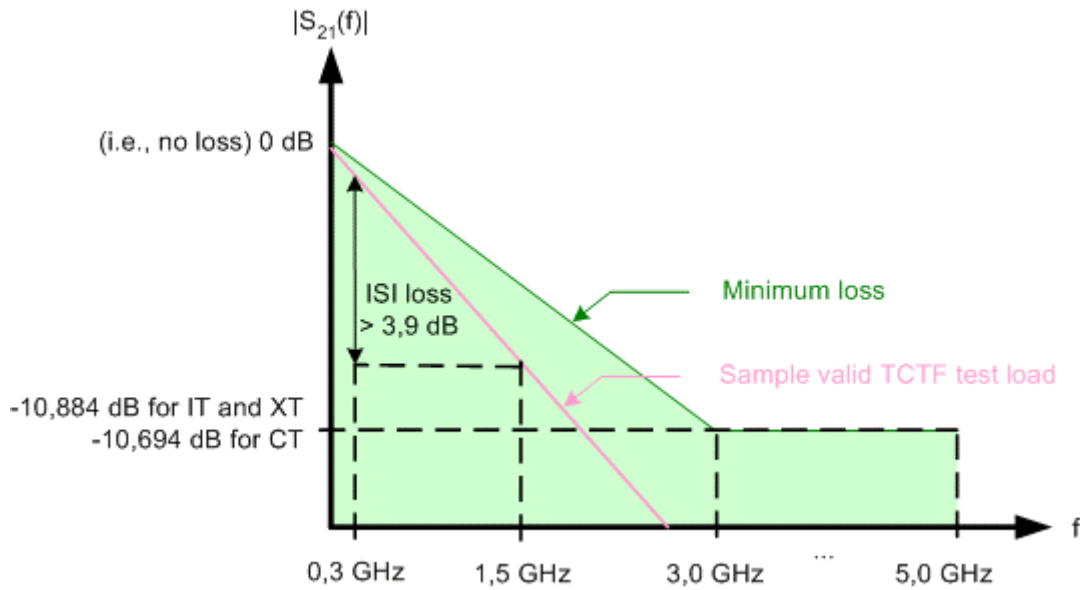

Figure 53 — ISI loss example TCTF  $S_{21}$  and ISI loss requirements at 3,0 Gbps

[Note to editor – Generate separate graphs for IT/XT and CT since the CT line is not straight.]

Figure 54 shows an ISI loss example the allowable  $|S_{21}(f)|$  and minimum ISI loss of a TCTF test load and the  $|S_{21}(f)|$  of a sample TCTF test load at 1,5 Gbps.

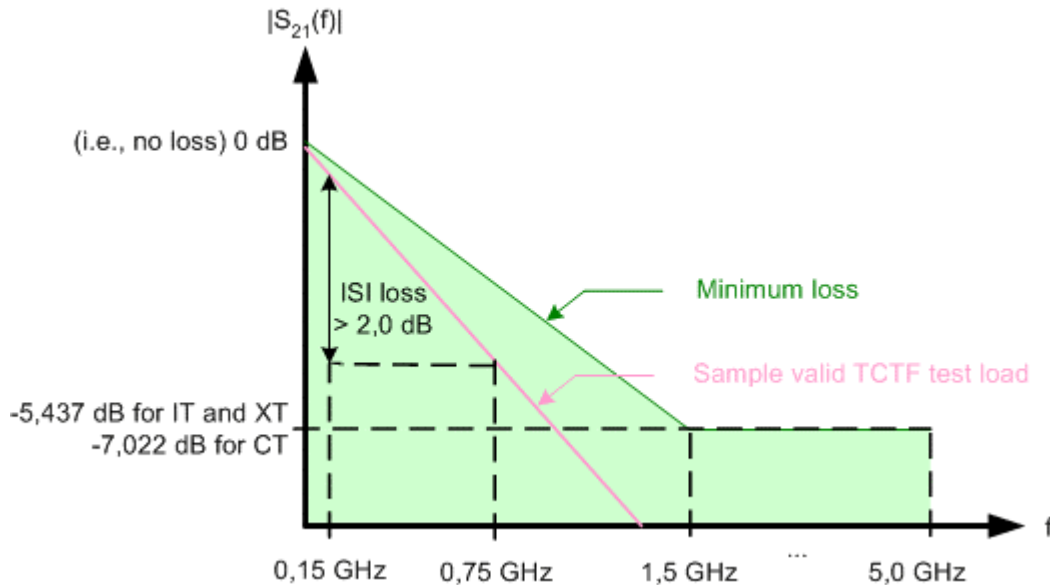

Figure 54 — ISI loss example TCTF  $S_{21}$  and ISI loss requirements at 1,5 Gbps