

## T10/04-030r4, SAS-1.1: Fix SP Hang States

To: T10 Technical Committee  
From: Robert Sheffield (Robert.L.Sheffield@intel.com), Intel Corporation  
Date: June 16, 2004  
Subject: T10/04-030r4, SAS-1.1: Fix SP Hang States

### **Revision History**

Revision 0 (January 7, 2004) first revision  
Revision 1 (May 5, 2004) SP0 transition on COMINIT from DWS Lost states, and add separate SATA\_SpinupHold state.  
Revision 2 (May 12, 2004) Add a description of state machine variables (and counters and timers) to the state machine conventions, clean up text on SP transitions, clear MgmtReset on all transitions out of SP7, and add COMINIT Detected trigger on transition from SP26 to SP0.  
Revision 3 (May 25, 2004) Remove COMINIT triggered transition from SP7 to SP0 because SATA drives may respond to COMSAS with COMINIT, causing a recurring loop-back to SP0. It's not a hang state because COMSAS timeout triggers transitions out.  
Revision 4 (June 16, 2004) In section 6.7.4, reword transitions from SP speed negotiation states to SP0 so as to list trigger conditions as an "or" list rather than separate sentences per request from editor at June-12 SAS WG teleconference. Fix spelling error (Chanage -> Change) in figure 61, and add COMINIT Detected triggers to transitions from SP19, SP20, and SP21 to SP0.

### **Related Documents**

SAS1.1-r04 – Serial Attached SCSI-1.1 revision 04

T10/04-029r3, SAS-1.1: Close Port Selector Detection Gap

- changes already reflected in this proposal assuming 029 is accepted first

### **Overview**

The SP state machine does not account very well for the possibility that attached target devices (SSP, STP, or SATA) may under certain conditions revert to the initial reset state transmitting COMINIT. There are several states in the SP state machine that do not monitor COMINIT Detected and will never advance to another state if the attached device reverts to transmitting COMINIT. SAS revision 5 does provide that when a phy receives COMINIT while in an SP state that is not monitoring COMINIT Detected, it should send a RESET request to the management application (which presumably would then issue a RESET causing the SP to revert to the SP0:OOB\_COMINIT state). However this does not provide the level of concise control that should be provided at the phy-layer of SAS.

Also, the current SP state machine discusses the SATA spinup-hold state, but defines no such state to reflect the condition. It is loosely identified as a condition in SP7:OOB\_AwaitCOMSAS when no explicit reset has been issued.

This proposal suggests adding state transitions in the SP state machine, triggered by COMINIT Detected, to each state that currently does not monitor COMINIT Detected and does not have an outbound transition defined based on an event initiated by the immediate phy (e.g. COMINIT Transmitted) to define the specific behavior of the SP state machine when the attached device reverts to transmitting COMINIT. The proposal also adds a formal SATA\_SpinupHold state along with clearly defined conditions for entry and exit reflecting explicit control through the application client.

### **Suggested Changes**

*Add subclause 3.1.159 to define state machine variables:*

**3.1.159 state machine variable:** A variable that may exist within the context of a state machine that may log status determined in one state that is used in another state of the same state machine affecting subsequent state transitions or state machine outputs.

*Add subclause 3.6.4 to describe the general conventions for the use of state machine variables, counters, and timers in state machines:*

#### **3.6.4 State machine counters, timers, and variables**

State machines may contain state machine counters, state machine timers, and state machine variables that affect the operation of the state machine. The scope of state machine counters, timers, and variables is the scope of the state machine itself. They are created and deleted with the state machines with which they are associated. State machine transitions specify the initialization and modification of state machine timers, counters, and variables. Transitions out of a state may be conditioned upon specific criteria regarding the current value of a state machine timer, counter, or variable. State machine timers may continue to run while a state machine is in a given state, and a timer may cause a state transition upon reaching a defined threshold value (e.g. 0 for a timer that counts down).

*In subclause 6.7.1 SP state machine overview, modify the second set of bullets on page 121 as follows:*

The SP state machine shall start in the SP0:OOB\_COMINIT state after:

- a) a power on;
- b) a hard reset; or
- c) receiving a Management Reset request from the management layer (e.g., from the SMP PHY CONTROL function in an expander device). ~~Receipt of a COMINIT in any state that does not have an exit transition triggered by receipt of COMINIT should cause a Management Reset request.~~

The SP state machine shall maintain a state machine variable, MgmtReset, to indicate whether SP0:OOB\_COMINIT was last entered due to a Management Reset, or a defined transition from another state (see subclause 6.7.3.2.1). If SP0:OOB\_COMINIT was last entered due to a Management Reset, it shall set MgmtReset to one. If SP0:OOB\_COMINIT was last entered by a defined transition from another state, it shall set MgmtReset to zero. MgmtReset shall be set to zero by any transition out of SP7:OOB\_AwaitCOMSAS.



*Modify subclause 6.7.3.2.1 State description (SP0:OOB\_COMINIT) as follows:*

**6.7.3.2.1 State description**

This state is the initial state for this state machine.

Upon entry into this state, this state shall:

- a) send a Transmit COMINIT message to the SP transmitter;
- b) send a Stop DWS message to the SP\_DWS state machine; and
- c) send a Phy Layer Not Ready confirmation to the link layer.

This state machine waits for receipt of a COMINIT Transmitted message and/or a COMINIT Detected message.

Entry to this state due to a power on shall set the ATTACHED SATA PORT SELECTOR bit in the DISCOVER response to zero. If this state receives a COMWAKE Detected message and the phy supports attachment to a SATA device (i.e. the phy is attached to an STP/SATA bridge) and also supports attachment to a SATA port selector, and the value of the ATTACHED SATA PORT SELECTOR bit in the DISCOVER response is zero, it shall set the ATTACHED SATA PORT SELECTOR bit in the DISCOVER response to one and send a SATA Port Selector Change confirmation to the link layer.

State machine variable MgmtReset shall be set to one if this state is entered due to a Management Reset request or SMP Reset request. MgmtReset shall be set to zero if this state is entered due to a power on, a hard reset, DWS Lost timeout, or COMINIT received.

*Add a new subclause in subclause 6.7.3.8 to define the transition from SP6 to SP0:*

**6.7.3.8.3 Transition SP6:OOB\_AwaitNoCOMSAS to SP0:OOB\_COMINIT**

This transition shall occur after receiving a COMINIT Detected message.

*Modify subclause 6.7.3.9 as shown to replace the transition to SP0, with a transition to SP26 for spinup-hold, and to specify use of the MgmtReset bit:*

**6.7.3.9.2 Transition SP7:OOB\_AwaitCOMSAS to SP0:OOB\_COMINIT**

~~This state shall send a SATA Spinup Hold confirmation to the link layer and perform this transition if:~~

- ~~a) this phy is in an expander device;~~
- ~~b) this phy supports attachment to a SATA device;~~
- ~~c) the COMSAS Detect Timeout timer expires;~~
- ~~d) this expander device implements SATA spinup hold; and~~
- ~~e) the SP0:OOB\_COMINIT state was not originally entered because of an SMP Reset request (i.e., SMP PHY CONTROL-based requests to reset the phy bypass spinup hold).~~

**6.7.3.9.2 Transition SP7:OOB\_AwaitCOMSAS to SP26:SATA\_SpinupHold**

This state shall send a SATA Spinup Hold confirmation to the link layer and this transition shall occur if,

- a) this phy is in an expander device;
- b) this phy supports attachment to a SATA device;
- c) the COMSAS Detect Timeout timer expires;
- d) this expander device implements SATA spinup hold; and
- e) the value of the MgmtReset machine state variable is zero.

This transition shall set MgmtReset to zero.

**6.7.3.9.3 Transition SP7:OOB\_AwaitCOMSAS to SP6:OOB\_AwaitNoCOMSAS**

This transition shall occur after receiving a COMSAS Detected message.

This transition shall set MgmtReset to zero.

**6.7.3.9.4 Transition SP7:OOB\_AwaitCOMSAS to SP16:SATA\_COMWAKE**

This transition shall occur if:

- a) the phy supports attachment to SATA devices; and
- b) the COMSAS Detect Timeout timer expires; and
- c) the value of the MgmtReset state machine variable is one.

This transition shall set MgmtReset to zero.

**6.7.3.9.5 Transition SP7:OOB\_AwaitCOMSAS to SP2:OOB\_NoCOMSASTimeout**

This transition shall occur if the phy does not support SATA and the COMSAS Detect Timeout timer expires.

This transition shall set MgmtReset to zero.

Replace figure 69 – SP (phy layer) state machine – speed negotiation states with the following figure:

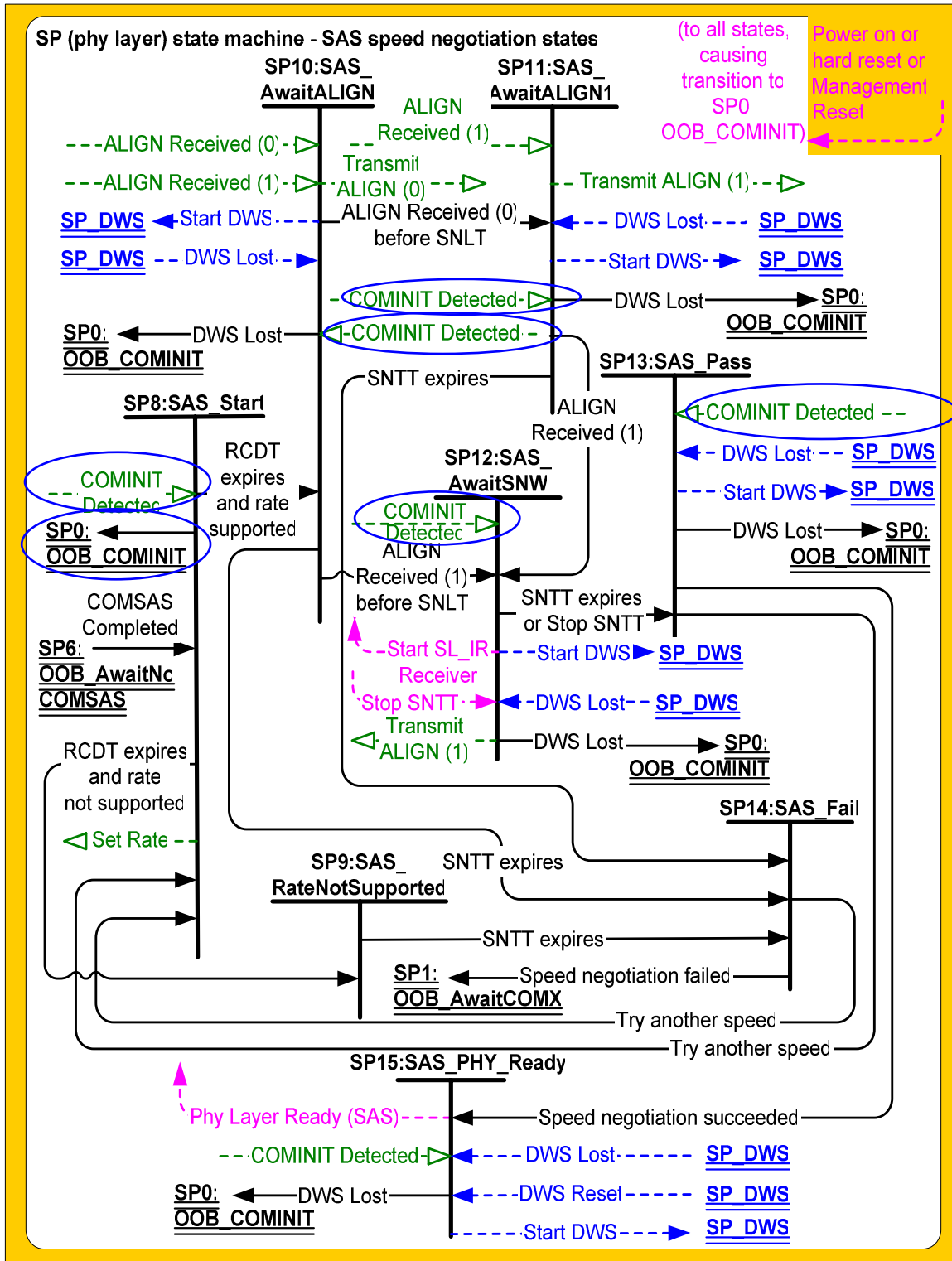

*Add subclause 6.7.4.2.4 describing the new transition to SP0 as follows:*

**6.7.4.2.4 Transition SP8:SAS\_Start to SP0:OOB\_COMINIT**

This transition shall occur after receiving a COMINIT Detected message.

*Modify subclause 6.7.4.4.2 to add COMINIT Detected as a transition trigger:*

**6.7.4.4.2 Transition SP10:SAS\_AwaitALIGN to SP0:OOB\_COMINIT**

This transition shall occur after receiving a DWS Lost message if this state does not send a Start DWS message, or after receiving a COMINIT Detected message.

*Modify subclause 6.7.4.5.2 to add COMINIT Detected as a transition trigger:*

**6.7.4.5.2 Transition SP11:SAS\_AwaitALIGN1 to SP0:OOB\_COMINIT**

This transition shall occur after receiving a DWS Lost message if this state does not send a Start DWS message, or after receiving a COMINIT Detected message.

*Modify subclause 6.7.4.6.2 to add COMINIT Detected as a transition trigger:*

**6.7.4.6.2 Transition SP12:SAS\_AwaitSNW to SP0:OOB\_COMINIT**

This transition shall occur after receiving a DWS Lost message if this state does not send a Start DWS message, or after receiving a COMINIT Detected message.

*Modify subclause 6.7.4.7.2 to add COMINIT Detected as a transition trigger:*

**6.7.4.7.2 Transition SP13:SAS\_Pass to SP0:OOB\_COMINIT**

This transition shall occur after receiving a DWS Lost message if this state does not send a Start DWS message, or after receiving a COMINIT Detected message.





*Add subclause 6.7.5.3.3 describing the new transition to SP0 as follows:*

**6.7.5.3.3 Transition SP17:SATA\_AwaitCOMWAKE to SP0:OOB\_COMINIT**

This transition shall occur after receiving a COMINIT Detected message.

*Add subclause 6.7.5.4.3 describing the new transition to SP0 as follows:*

**6.7.5.4.3 Transition SP18:SATA\_AwaitNoCOMWAKE to SP0:OOB\_COMINIT**

This transition shall occur after receiving a COMINIT Detected message.

*Modify subclause 6.7.5.5.3 describing the transition from SP19 to SP0 as follows:*

**6.7.5.5.3 Transition SP19:SATA\_AwaitALIGN to SP0:OOB\_COMINIT**

This transition shall occur if the Await ALIGN Timeout timer expires or after receiving a DWS Lost message or after receiving a COMINIT Detected message.

*Modify subclause 6.7.5.6.2 describing the transition from SP20 to SP0 as follows:*

**6.7.5.6.2 Transition SP20:SATA\_AdjustSpeed to SP0:OOB\_COMINIT**

This transition shall occur after receiving a DWS Lost message, or after receiving a COMINIT Detected message.

*Modify subclause 6.7.5.7.2 describing the transition from SP21 to SP0 as follows:*

**6.7.5.7.2 Transition SP21:SATA\_TransmitALIGN to SP0:OOB\_COMINIT**

This transition shall occur after receiving a DWS Lost message, or after receiving a COMINIT Detected message.

*Add subclause 6.7.5.9.4 describing the new transition to SP0 as follows:*

**6.7.5.9.4 Transition SP23:SATA\_PM\_Partial to SP0:OOB\_COMINIT**

This transition shall occur after receiving a COMINIT Detected message.

*Add subclause 6.7.5.10.4 describing the new transition to SP0 as follows:*

**6.7.5.10.4 Transition SP24:SATA\_PM\_Slumber to SP0:OOB\_COMINIT**

This transition shall occur after receiving a COMINIT Detected message.

*Add subclause 6.7.7 describing the new SATA Spinup Hold state as follows:*

**6.7.7 SATA Spinup Hold state**

**6.7.7.1 State description**

Figure 72 shows the SP26:SATA\_SpinupHold state. This state shall be entered from the SP7:OOB\_AwaitComsas state upon detection of a COMSAS detect timeout if the phy supports SATA, the phy supports Spinup Hold, and the MgmtReset state machine variable has a value of zero.

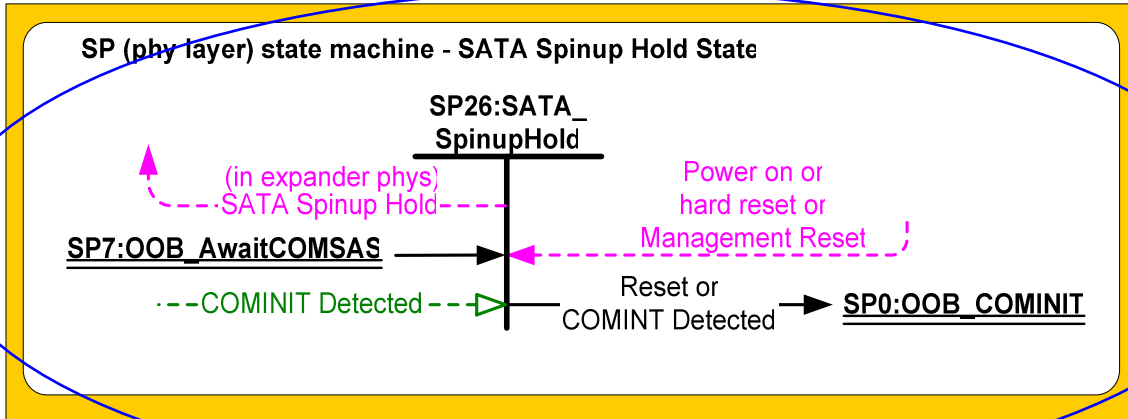

Figure 72 — SP (phy layer) state machine – SATA Spinup Hold State

**6.7.7.2 Transition SP26:SATA\_SpinupHold to SP0:OOB\_COMINIT**

This transition shall occur if this state receives a COMINIT Detected message, a Management Reset request from the management layer, a hard reset, or a power on. If this transition is caused by a Management Reset Request from the management layer, it shall cause MgmtReset to be set to one upon entry to SP0:OOB\_COMINIT. Otherwise, MgmtReset shall be set to zero upon entry to SP0:OOB\_COMINIT.