

Passive interconnect performance working group (PIP) 02-082r0
February 21, 2002
Scotts Valley, CA

Subject: Draft minutes for the SCSI passive interconnect performance working group, PIP, in Scotts Valley, CA on February 21, 2002

Zane Daggett, chair, led the meeting. Bill Ham, secy, took these minutes. Umesh Chandra of Seagate hosted the meeting.

Previous approved minutes: 02-019r1

1.	Introduction.....	1
2.	Attendance.....	2
3.	Agenda development.....	2
4.	Approval of previous minutes.....	2
5.	Review of action items.....	3
6.	Administrative structure:.....	3
7.	Review of industry activities.....	3
8.	Presentations on new topics.....	3
8.1	Differential capacitance testing for PIP, Greg Vaupotic Spectra Strip.....	3
8.2	Specifications that fall outside of the present SCSI specifications, Greg Vaupotic, Spectra strip.....	4
9.	Presentations on old topics.....	4
9.1	Survey of current (last 10 years) literature on PIP - type measurements and design, Larry Barnes, FOREL Enterprises.....	4
10.	Effects of non-uniformities and/or periodic structures.....	4
11.	Round robins.....	4
11.1	Bulk cable round robin 1.....	5
11.2	Bulk cable round robin 2 (Expanded parameter set), Greg Vaupotic, Amphenol Spectra Strip.....	5
11.2.1	Status of bulk cable round robin 2.....	10
11.3	Backplane round robin 1, Umesh Chandra, Seagate.....	11
11.4	Cable Assembly round robin 1, Martin O., Molex.....	12
11.4.1	Update / con call minutes review, Martin O., Bob G.....	13
11.5	Frequency dependence of dielectric constant test methodology round robin - Barnes, LSI Logic; Vaupotic, Spectra strip.....	23
12.	Proposed new round robins.....	23
13.	PIP documentation - Daggett.....	23
13.1	Actions required to produce a ballotable PIP document, group.....	24
13.2	Definitions for the document - Barnes.....	24
13.3	Conversion of the document into Frame from Word.....	24
13.4	Report from last editors meeting.....	24
13.5	Document review, Zane.....	24
14.	Old business.....	24
14.1	Skew measurement and specification methodology, Ham.....	24
15.	New business.....	24
15.1	SSDB position for PIP.....	25
16.	Next meetings.....	25
17.	Action Items:.....	25
17.1	Old action items from previous meetings.....	26
17.2	New actions from this meeting.....	27
18.	Adjourn.....	27

1. Introduction

Zane Daggett, chair, opened the meeting, thanked the host, conducted the introductions, and reviewed the meeting purpose.

2. Attendance

The following were present:

Name	Organization	e-mail	Phone
Lee Hearn	Adaptec	Lee_hearn@adaptec.com	408-957-6853
Richard McMillan	Adaptec	Richard_mcmillan@adaptec.com	408-957-6025
Greg Vaupotic	Amphenol Spectra-Strip	gvaupotic@spectra-strip.com	203-287-7425
Bill Ham	Compaq	Bill_ham@ix.netcom.com	978-828-9102
Bob Gannon	Electronica Pantera	bgannon@snet.net	860-537-6800
Larry Barnes	Forel	forel@pcisys.net	719-265-9679
Zane Daggett	Hitachi Cable	zdaggett@hcm.hitachi.com	603-669-4347 x.236
Thom Kreusel	HP	thom_kreusel@hp.com	
Jie Fan	Madison	jie.fan@madisoncable.com	508-752-2884 x 306
Richard Uber	Maxtor	richard_uber@maxtor.com	508-770-2568
Martin Ogbuokiri	Molex	mogbuokiri@molex.com	630-527-4370
Umesh Chandra	Seagate	umesh_chandra@seagate.com	831-439-7264
Himanshu Desai	Seagate	himanshu.r.desai@seagate.com	831-439-5282
Paul Aloisi	Texas Instruments	paul_aloisi@ti.com	603-222-8687
Don Getty	Texas Instruments	donald_getty@ti.com	408-246-3100 Ext. 41

3. Agenda development

The agenda shown was that used.

4. Approval of previous minutes

Motion (Ham / Barnes) that the draft minutes from the previous meeting be approved as modified. Motion passed unanimously.

The methodology for minutes uses the draft/approved minutes scheme with posting to the t10 web site of the minutes as the vehicle for publication. Postings are announced to the SCSI reflector after the posting is verified to be on the web site.

Minutes will be in .pdf format.

5. Review of action items

Action items were reviewed and the status is listed below in the action items section.

6. Administrative structure:

The present administrative structure is:

Chair: Zane Daggett, Hitachi
Vice Chair: Greg Vaupotic, Amphenol Spectra Strip
Secretary: Bill Ham, Compaq

7. Review of industry activities

Bill Ham briefly reviewed the T10, T11, and SFF activities relating to testing and modeling. He noted that the T11 modeling activity has had its eighth meeting and is in the process of producing its first draft document which has been posted on the T11 web site. The next FCSM meeting is scheduled for T11 week in April 2001.

Bill noted the present activities relating to 3 gig and 4 gig speeds as the next stop for Fibre Channel disk drive interface.

The SFF SSWG on high speed serial performance has adopted a duality policy where either time or frequency domain is acceptable. This requires use of special conversion tools provided by atSpeed. Test fixture effects are taken into account right at the interconnect boundary. Agreement of better than 2% was demonstrated for 1 Gigabaud signals created by transforming TDT measurements into frequency domain and back again (convolving with the data pattern used) and direct measurement of eye diagrams.

8. Presentations on new topics

8.1 Differential capacitance testing for PIP, Greg Vaupotic Spectra Strip

Greg presented the case that the differential capacitance measurement as documented in SPI-3 and SPI-4 is not practiced. He recommended that we remove this measurement methodology from the suite and substitute an extraction method. Differential capacitance will be extracted from a calculation from differential impedance (square root of L/C) and differential propagation time (square root of LxC). Sample lengths are to be determined and may vary with construction.

Greg is actioned to prepare a detailed proposal for the revised measurement process.

8.2 Specifications that fall outside of the present SCSI specifications, Greg Vaupotic, Spectra strip

The subject of whether closed systems (i.e. systems that are used with a specific set of components in a specific configuration) are part of PIP. It was pointed out that the measurement processes supported in PIP are all aimed at open applications but that the measurement methodologies could be applied with different pass/fail criteria to allow level 1 testing for closed systems. Of specific concern is lower impedance bulk cable when used with loaded sections. This lower impedance is only valid if certain loading distributions are in place in the same segment.

PIP took a formal position in August 2001 that the open concept would be the one supported.

A discussion of this issue will be placed in the overview section of the PIP document.

9. Presentations on old topics

9.1 Survey of current (last 10 years) literature on PIP - type measurements and design, Larry Barnes, FOREL Enterprises

Larry presented approximately 20 sources of material that relate to PIP measurements. Larry is actioned to combine these files into a single file and post on the T10 site. Folks are encouraged to look at these references and determine if any content is relevant to the PIP project.

10. Effects of non-uniformities and/or periodic structures

no new discussion

11. Round robins

A new document has been created to document the details of the round robin testing activities for PIP that have been substantially completed. All details for completed round robins will be contained in this new document and will be removed from the active minutes. At the moment the only round robin in this category is cable media round robin 1. Please see the new document "PIP round robin testing" for information about cable media round robin 1.

The following motion made in a previous meeting is retained due to its important content for round robin testing.

Motion Daggett/Martin O that samples used for round robins will be identified by the manufacturer of the samples in the active minutes unless the manufacturer specifically requests that his sample be identified in a way that does not indicate the manufacturer. It is understood that the final published results and details in the "PIP round robin testing" document will not contain any manufacturer identifications.

Motion passes 11/0/1

11.1 Bulk cable round robin 1

This round robin is no longer active

[Data from this round robin has been transferred to 01-076.

11.2 Bulk cable round robin 2 (Expanded parameter set), Greg Vaupotic, Amphenol Spectra Strip

[Material in this section is retained in the minutes until such time as the report for this round robin is complete enough to transfer to 01-076. Progress was made - see section on status]

Round robin 2 is based on a significantly more precise specification of the measurement details than round robin 1.

OBJECTIVE

For several characteristics, determine simplest measurement method which compares favorably to the best method. This is accomplished by measuring several samples using several methods, with results being compared later. Most Round-Robin participants will not be able to use all methods; each will do what they can.

DATA PRESENTATION

- Data presented in MS Excel spreadsheets, for later by compilation by coordinator. Participants not able to present electronically are, of course, permitted to present data as recorded.
- Graphs/plots presented prior to final compilation shall be 1 to 1000 MHz, log frequency, even though impedance data is only collected down to 10 MHz. This facilitates comparing data sets for resonance effects.
- Report impedance as differential Ohms. "Attenuation" shows gain as dB / meter.
- Report Propagation time Skew as measured (e.g.: 127 ps / 25 meter length) as table (Excel).

SAMPLES

All samples are 25 meter length. Unshielded samples (twisted pair ribbons) are to be suspended from ceiling, with minimum of crossovers and keeping sample as spread out as possible (to minimize crosstalk effects).

Sample 1 Round twisted pair cable having overall shield, 28 AWG 7-36 TC (Hitachi)

Measure pairs 1 (Heat shrink 1), 7 (Heat shrink 2), and 34 (Heat shrink 3) (each pair to be secured with heat shrink tubing)

Sample 2 Round twisted pair cable having overall shield, 30 AWG solid TC (Madison)

Measure pairs 1 (Heat shrink 1), 7 (Heat shrink 2), and 34 (Heat shrink 3) (each pair to be secured with heat shrink tubing)

Sample 3 Twisted pair ribbon having no flats. (Spectra-Strip)

Measure pairs 1, 3, and 5 (wires 1-2, 5-6, and 9-10)
Sample 4 Twisted pair ribbon having flats at TDB inch intervals
(Hitachi)
Measure pairs 1, 3, and 5 (wires 1-2, 5-6, and 9-10)

ATTENUATION

Record S21 using log scale (really is gain). Use 30 Hz IF BW. Where possible, use 401 points. Record from 1 to 1000 MHz, log sweep. In addition to recording sweep, record actual values (using "markers") at 80, 160, and 200 MHz.

Balun Methods, using fixture described in 00-339r0 (balun with matching resistors). For consistency, use matching network comprised of one 68 Ω shunt and two 47 Ω series resistors (1/8 W 5% carbon).

Method A Calibrate by storing fixture response. Then measure sample. Then remove fixture response. ("normalized")

Method B Full 2-port calibration. Use 121 $\Omega \pm 1\%$ chip resistor (Panasonic EJR series) for "load", for "short" solder test points of fixture together, for "open" position matching resistors as will be when measurement is made. For "thru", attach both fixtures together.

4-port Network Analyzer Methods:

Method C Full 4-port calibration. Calibrate for 100 Ω environment.

Method D Full 4-port calibration. Calibrate for 122 Ω environment (software "corrects" for Z).

DIFFERENTIAL IMPEDANCE

Use 30 Hz IF BW. Where possible, use 401 points. Record from 10 to 1000 MHz, log sweep.

Hybrid Junction Method

Method E See Appendix 1 for outline regarding fixture and calibration.

4-port Network Analyzer Method

Method F Full calibration of one differential port. Calibrate for 100 Ω environment.

SKEW PAIR to PAIR

Per SPI-3 TDR method. Please record propagation time of each leg of each pair. Pair propagation time is the average of these two readings. Doing this allows us to examine within pair skew.

Pair #	Propagation time + signal	Propagation time - signal	Pair propagation time Average (+,-Sig)
1 (or shrink 1)			
3 (or shrink 2)			
5 (or shrink 3)			

LOGISTICS

Companies providing a sample will send to first name on below list. Round cable sample shall be on spools. Flat cable sample shall be on pads.

The first person on the list will send samples to second person. The second to the third, and so forth.

Company	Person	Address	
Amphenol Spectra-Strip	Greg Vaupotic (203) 287-8725	720 Sherman Ave Hamden CT 06410	greg.vaupotic@snet.net
Hitachi Cable	Zane Daggett (603) 669-4347	900 Holt Avenue Manchester NH 03109	zdaggett@hcm.hitachi.com
Madison Cable	Jie Fan (508) 752-2884	125 Goddard Memorial Dr. Worcester MA 01603	jie.fan@madisoncable.com
Seagate	Umesh Chandra (831) 439-7264	4585 Scotts Valley Drive Scotts Valley CA 95066	Umesh_chandra@seagate.com
Madison Cable (retest)	Jie Fan (508) 752-2884	125 Goddard Memorial Dr. Worcester MA 01603	jie.fan@madisoncable.com
Hitachi Cable (retest)	Zane Daggett (603) 669-4347	900 Holt Avenue Manchester NH 03109	zdaggett@hcm.hitachi.com
END	Greg	720 Sherman Ave	greg.vaupotic@snet.net

Amphenol Spectra-Strip	Vaupotic (203) 287-8725	Hamden CT 06410	et
------------------------	-------------------------	-----------------	----

TEST METHOD CAPABILITIES

Table below shows anticipated test capabilities of participants.

Company	Balun A	Balun B	4-port C	4-port D	Hybrid E	"4-port" F
Amphenol	yes	yes	maybe	maybe	yes	maybe
Hitachi Cable	yes	yes	no	no	yes	no
Madison Cable	no	no	yes	yes	no	yes
Seagate	yes	yes	no	no	yes	no
Adaptec	tbd	tbd	yes	yes	tbd	tbd

APPENDIX 1

Hybrid Junction Test Fixture

The hybrid junction converts an unbalanced 50 Ω input into two balanced 50 Ω outputs (two signals having 180° phase, 100 Ω differential). The selected hybrid junction is the M/A-COM

H-183-4. This is specified from 30 MHz to 3 GHz. However, it may be used from 10 MHz to 3 GHz when used with a careful calibration.

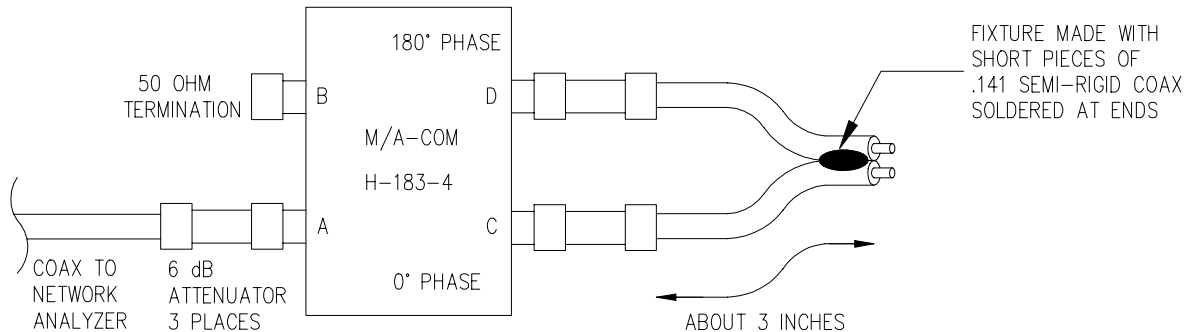

OUTLINE for Calibration Procedure

Attach fixture to analyzer port 1. Semi-rigid coax strongly recommended.

Preset Network Analyzer to default condition. Then set analyzer to:
Power = 10 dBm Points = 401 Linear Sweep (??) Start = 10 MHz
Stop = 1 GHz
30 Hz IF BW

With attenuators attached, BUT with semi-rigid fixture removed, calibrate port 1. This is accomplished using precision standards attached to the two attenuators on the right. Two sets of standards are required.

When finished calibrating port 1, attach semi-rigid coax fixture (which, having no sample attached, is an "open" circuit)

- Set analyzer to look at S11 Phase. Set phase scale to 10° per division.
- Enable port extensions
- Adjust port-1 extension for 0° across the frequency range (expected for an open circuit). This compensates for the fixture's propagation propagation time. Above 800 MHz, it will not be possible to achieve exactly 0°. This is because the fixture is not a perfect open circuit. The attachment stubs cause small undesired parasitics. (Port extension for above fixture is about 380 ps.)
- Set the analyzer to look at S11 Set Z Reflected = On Set scale = Linear

Important - The analyzer has been calibrated to 50 Ω . The actual impedance at the calibration plane was, in fact, 100 Ω differential. Multiply measurements by two for differential impedance.

Measurement using Open/Short Method

Two measurements are required for each pair that is examined. First, record the impedance of the pair with the far-end "open". Then record again with the far end "shorted". The impedance is then calculated with the following equation:

$$Z = \sqrt{(Z_{\text{OPEN}})(Z_{\text{SHORT}})}$$
 This is the value to report.

11.2.1 Status of bulk cable round robin 2

[Greg V. presentation in February 2002:]

Greg presented data from three different companies at the February meeting. There was general agreement between Spectra Strip and Seagate on the S21 data for round cable while the Madison data diverged significantly from the other two for twist and flat bulk cable.

One major difference was that Madison used a 4 port network analyzer (no baluns) while Spectra strip and Seagate used a 2 port with a balun. There was no agreement on whether the 4 port or the 2 port was more accurate.

Seagate's first data showed significant structure above approx 500 MHz which may be due to the details of how the balun fixture was built.

The possibility of additional resonant conditions caused by the details of the measurement was raised.

For twist and flat samples there was serious disagreement between the 2 port with baluns and the 4 port with no baluns. The 4 port measurements made the samples appear much better. Other details of the measurement process were also identified. Some additional experimentation is expected to be done by Amphenol Spectra Strip before the next meeting.

In any case there are critical details that must be tied down before we have any confidence in high frequency measurements or on non-uniform constructions.

[End of status update for February]

Madison (retest) now has the samples and will forward to Hitachi (retest) in the sequence shown in the chart.

All samples are 25 meter length.

Hitachi Cable Manchester: Sample 1

Round twisted pair cable having overall shield, 28 AWG 7-36 TC (Hitachi)

Prep both ends:

pair 1 (Heat shrink 1),
pair 7 (Heat shrink 2),
and pair 34 (Heat shrink 3) (each pair to be secured with heat shrink tubing)

Madison: Sample 2

Round twisted pair cable having overall shield, 30 AWG solid TC (Madison)

Prep both ends:

pairs

1 (Heat shrink 1),
7 (Heat shrink 2),
and 34 (Heat shrink 3) (each pair to be secured with heat shrink tubing)

Spectra-Strip: Sample 3

Twisted pair ribbon having no flats, 30 AWG Solid TC

Zane: Sample 4

Twisted pair ribbon having flats at 250mm intervals (Hitachi)

Seagate has an update in August meeting in the form of 01-256r0.

Differences in the data presentation between the Seagate and the Amphenol of approximately 20 dB were noted. It was determined that this difference is probably due to the attenuation of the test fixture being included in the data presented by Seagate.

This is yet another example of the critical importance of following the details of the instructions for executing both the measurement process and the data presentation process if one desires to have agreement.

Greg foresees a follow-on round robin with a more complete suite of tests and draft procedures including both those used in round robin 2 and other tests not included in round robin 2 but viewed as useful.

Status: Seagate has corrected the measurement process and has forwarded to Greg V. Greg is preparing a summary of results. Agreement is vastly improved with this correction (to within less than 1dB).

The cables are now on their way to Hitachi.

11.3 Backplane round robin 1, Umesh Chandra, Seagate

[New info in February]

Present status: LSI, Seagate, and Maxtor has completed the first round and the boards will be passed to JPM. Seagate has significantly progressed on the results report.

[Below this point material is retained until round robin is completed.]

This effort is needed to add backplane testing methodology to the test suite. The basic idea is to acquire some small selection of SCSI backplanes and send these around for testing at different companies.

Umesh is actioned to select 2 boards for use in the round robin.

Umesh has documented the procedure in 01-132r0.

Participants include: Seagate, LSI Logic, Maxtor, JPM

Umesh has certain hardware that could be useful in exciting the interconnect under test. This round robin will focus on the "Data spewing" card (disk drive card) (renamed in this meeting to SSDB) with a data interface through the SCA connector that allows programming of the data pattern through an HBA using the SCSI transport.

Motion Ham / Umesh that PIP will document a cost effective eye diagram based test methodology for passive interconnect that will be part of a test suite for performance requirements.

Motion passes 10/0.

It was agreed in the August 2001 meeting that a SCSI signal driver board (SSDB) will be used for eye diagram based testing. This board should be able to control the signal rise time, signal amplitude, fall back level, and possibly other parameters. A methodology of adjusting the requirements at the receive mask to account for the fact that the SSDB does not deliver the worst case allowed signal will be used.

11.4 Cable Assembly round robin 1, Martin O., Molex

[No new update in February 2002]

The present (20011211) status:

Foxconn (Jason Chou) complete, JPM has completed, Molex complete, next to C&M which is the end. Some inconsistencies are being found with the attenuation data due to test fixture differences. Significant inconsistencies have been found. Large contributions to cross talk are coming from the connectors and transition regions in the cable assemblies.

Consensus is that the test fixture design used by Molex should be the documented in PIP for the parametric measurements. No signal degradation data is available due to lack of SSDB's. Assumption is that the test fixture for cable assemblies is an SSDB which includes an adapter assembly if required to accommodate the interconnect assembly under test.

[material after this point is retained in the minutes until transferred to the round robin results document.]

Martin O. presented his view of the content and timing of this round robin. As there was not enough time to explore all the details in this meeting needed to structure a "good" round robin a reduced, two company round robin will be completed before February 2001. Martin agreed to structure a preliminary round robin intended to refine the parameters of the real cable assembly round robin 1. The companies that will deliver results to the February meeting are Molex and JPM.

As this is the first attempt to do a round robin on cable assemblies and since the details of the tests for cable assemblies are still not defined this round robin must be considered as a preliminary investigation of test methods.

11.4.1 Update / con call minutes review, Martin O., Bob G.

Document contains minutes from two separate teleconference.

Notes by Martin O. from 2/15/01 Teleconference for PIP round robin cable assembly testing .

1. Update on the PIP round robin cable assembly:

a) The following cable assemblies have been received by Molex:

Sample A-[30 (7/38) AWG non shielded flat multidrop Micro Quick Twist] Hitachi Cable Manchester

2m total length built from a 2m section of the 10m supplied.
500mm center to center drops with a total of 5 HD68 connectors

Sample B-[30 (7/38) AWG non shielded round multidrop] Madison Cable Corporation

2m total length built from a 2m section of the 10m supplied. 500mm center to center drops total 5 connectors HD68 Connectors

Sample C-[30 AWG solid non shielded twisted flat point to point]

Spectra-Strip (Amphenol) (without flats on the ends)

6m total length built from a 6m section of the 20m supplied. VHDCI connectors on the ends (last resort HD connectors)

Sample D-[30 AWG solid shielded round point to point] Madison Cable Corporation

6m total length made from 6m of a total of 20m supplied.
VHDCI connectors on the ends.

Sample E-[34 AWG solid shielded round point to point] Temp-flex

6m total length made from 6m of a total of 20m supplied.
VHDCI connectors on the ends.

2. There were concerns that the idt termination will be damaged after several repeated plug in and plug out in the course of testing. A couple of remedies were suggested: 1) To make several samples with identical characterizations. 2) To use adapters to protect the damage to the connector/cable termination. 3) To eliminate damaged lines in the course of the round robin and collect data only where the lines are in good condition.

3. Impedance Measurement:

Network analyzer impedance measurement was ruled out as an option because of measurement difficulties for the sample lengths.

Everyone in the meeting agreed to use TDR measurement instrument. Also everyone confirmed he or she has TEK 11801 available.

There was a measurement resolution concern measuring with launch signals at 1 ns. It was suggested to add impedance measurement at launch signals of 500 ps risetime.

4. Attenuation measurement:

It was pointed out that the SPI-4 spec recommended attenuation measurement with raw cable lengths that can yield 6 dB loss.

Since the cable assemblies are fixed in length, the group plan to come up with measurement method to be reviewed in the next week meeting. This was an action item for Molex.

5. Group member update:

Notes by Zane D. from 12/19/00 conference call as amended in this meeting.

1. Discussions on cables to use for the test.
 - a. Cable assemblies?
 - b. Point to Point!
 - c. Multi-drops!

2. Availability of connectors and tooling.

3. Cable shipping packaging and total lengths.
 - a. See above

4. Time frame for cable delivery and shipping address.
 - a. Send to Bob Gannon
 - b. By the 29th of December all samples should be in Bob Gannon's hands. Attn: Mario Sahagun
JPM Pantera
Montemorelos No. 121
Fracc. Loma Bonita
Zapopan, Jalisco 45060 Mexico

5. Run down of tests to be conducted by Molex and JPM.
 - a. Attenuation [1Mhz to 1Ghz]
 - b. Crosstalk [NEXT & FEXT - TDR]
 - c. Impedance [Diff- first company to test needs to organize a conf. call to discuss test parameters TDR]
 - d. Propagation time [Time Domain TDT] for entire length
 - e. Number of pairs to test is 6 pairs. 2 pairs from the center 4 pairs against the shield. In the case of flat cable, test 2 from each edge and ACK and REQ in the inner pairs of the cable.
 - f. Basically data pairs 10, 11, 12 & 13 then ACK and REQ pairs. However, Bob Gannon can change these parameters if he feels it is necessary. It is requested, though, that we leave ACK and REQ in the pairs identified.

6. Time frame for phase 1 cable round robin test.
 - a. February 6th is the final deadline for testing
 - b. It is requested that JPM and Molex complete the testing by the February meeting.
 - c. All samples will be sent to Bob Gannon at JPM then built and tested by JPM.
 - d. Bob Gannon of JPM will forward samples to Martin O. at Molex.
 - e. Martin O. of Molex will make fixtures and send them onto Bob Gannon by January 5th.
 - f. Bob Gannon will need to test and send samples to Martin at Molex by the 16th of January (Bob to coordinate other time arrangements with Martin). Both JPM and Molex will present results at the next meeting in February, schedule in S. California.
 - g. Ken Plourde Temp-flex to submit sample E to Bob Gannon by Friday Feb 23. Bob will make the assembly and send to Martin at Molex by March 02.

The following is detail of Martin O's proposed test procedures for cable assembly round robin 1.

Objective:

This note describes a set of test to characterize the electrical performance of cable assemblies for the cable assembly round robin test. Test will be conducted at different locations and data and methods compared for measurement data consistencies. This will be accomplished by measuring several samples, and results compared later. Most Round-Robin participant will not be able to conduct all tests, each will do what they can.

Samples:

Sample A-[30 (7/38) AWG non shielded flat] Hitachi Cable
Manchester Micro Quick Twist with 2m build sampling 10m
500mm center to center drops total 5 cables HD Cables

Sample B-[30 (7/38) AWG non shielded round] Madison Cable
Corporation Round non-shielded with 2m build sampling 10m
500mm center to center drops total 5 cables HD Cables

Sample C-[30 AWG solid non shielded round] Spectra-Strip
(Amphenol) Flat Twisted cable (with or without flats on the ends)
with 6m build sampling 20m
Point to point at 6m, VHDCI cables

Sample D-[30 AWG solid shielded round] Madison Cable Corporation
Round shielded cable with 6m build sampling 20m, Point to point at
6m,
VHDCI cables

Test Parameter:

- a. Attenuation [1Mhz to 1Ghz]
- b. Crosstalk [NEXT & FEXT - TDR]
- c. Impedance [Diff- TDR]
- d. Propagation time [Time Domain TDT] for entire length
- e. Number of pairs to test is 6 pairs. 2 pairs from the center, 4 pairs against the shield. In the case of flat cable, test 2 from each edge and ACK and REQ in the inner pairs of the cable.
- f. Basically data pair 10, 11, 12 & 13 then ACK and REQ pairs

Test Equipment:

1. Network Analyzer
2. TDR
2. Molex Proprietary Test Fixtures
4. Coax Test Leads
5. Differential Baluns

Attenuation:

Frequency domain Measurement conducted in differential mode.
Record S_{21} using log scale. Use 30 Hz IF bandwidth. For better resolution, use 1601 points. Record from 1Mhz to 1GHz. Use Log frequency sweep. Also record values at 80, 160, 200, and 320 MHz.

Test Setup:

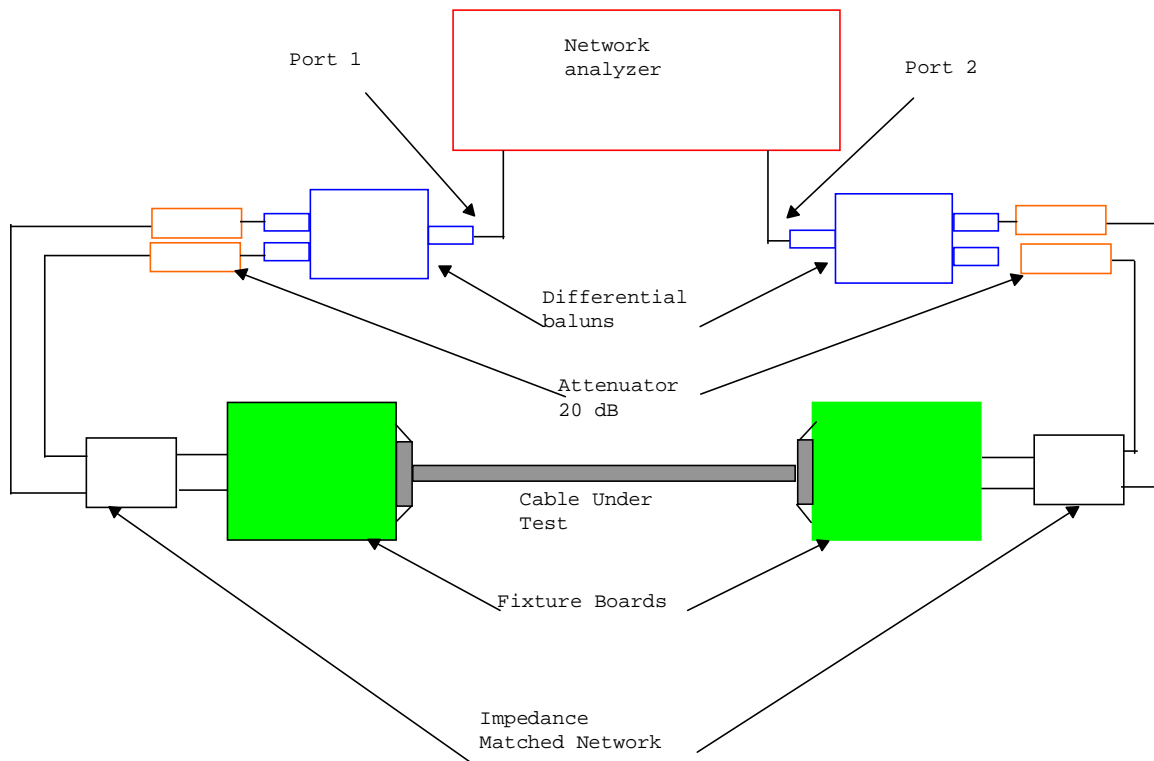

Figure 1 - Test setup

Test conditions

A network analyzer is used both as the source of the test signal and as a means of measuring the cable attenuation.

The cal kit contains the precision coax cables and the connector system whose models are stored in the analyzer memory for error correction purposes.

Test Fixture Board Validation

Measure the impedance of the test fixture board with a 35 ps launch signal. The impedance of the SMA or launch pad on the board shall remain in the range of 50 to 65 ohms for a 61 ohm controlled impedance board. See fig. 2 for a comparison profile between traditional and acceptable test fixture board impedance for measurements up to 10 GHz signals. For the case of the traditional impedance profile, use matching

impedance network to reduce the effect of the SMA or pad. The blue curve is acceptable. The red curve is not acceptable.

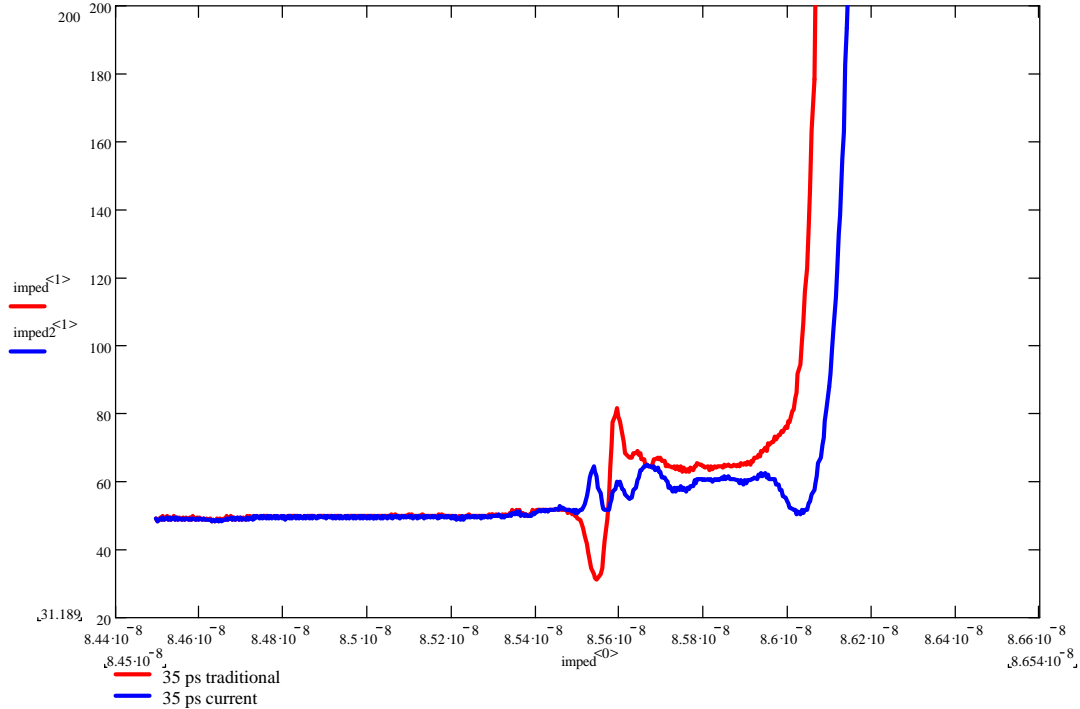

Figure 2 - Test board validation

Measurement Issues:

For a long electrical delay device such as a cable, the network analyzer presents some unusual measurement problems when operating in swept frequency mode. Often the measured response depends on the analyzer's swept time, and incorrect data may be obtained. The magnitude of the response can drop at faster sweep rate and look distorted. At slower sweep rate correct magnitude can be measured. The result may indicate that a cable has more loss than it truly does or it may indicate presence of ripples which is truly not there.

The cause of the measurement problem arise when using a network analyzer to measure a devise that has long electrical delay, dt , the device's time delay causes a frequency shift between it's input and output signals. The frequency shift, df equals the product of the sweep rate and the time delay.

Since frequency is changing with time as the analyzer sweeps, the time delay of the DUT causes a frequency offset between its input and output. In the analyzer receiver, the test and reference input signals will differ in frequency by df . Because the test signal frequency is slightly different than the receiver frequency, the analyzer will err in measuring its magnitude or phase. The faster the analyzer's sweep rate the larger df becomes, and the larger the error in the test channel.

To improve the measurement accuracy, decrease the sweep rate or decrease the time delay. We will choose to decrease the time delay. Since the time delay is the property of the test device, the better thing to do is decrease the delay difference between the R channel and the B channel. This can be achieved by adding a length of cable with equal electrical length as the test device. This length of cable can be inserted between the R channel in and out connectors on the front panel of the analyzer. The delay of this cable must be less than 5 usec.

Differential Impedance:

The impedance will be measured using a Time Domain Reflectometer (TDR) system. TDR employs a step generator and an oscilloscope to capture signal reflections due to device discontinuities. This test will use a 500 psec risetime step signal for the launch signal. As the step propagates through the test fixture and the cable under test, any discontinuities will cause voltage reflections back into the scope. These reflected voltages are used to calculate the reflection impedance of the cable under test.

Test conditions

A Time Domain Reflectometry system (TDR) is used both as the source of the test signal and as a means of measuring the reflected signals of the test device.

Two precision coax cables whose characteristic impedance matches the impedance of the TDR system, are used to connect the test fixture to the TDR system.

The launched signal is adjusted for 500 psec. risetime.

The schedule and sequence is still under development: the first three are Molex, JPM (has it now may go back to Molex for new test fixture, and Madison, Hitachi, Foxconn, TDA, C&M, Tempflex, Amphenol (AIPC)?,

Propagation Time:

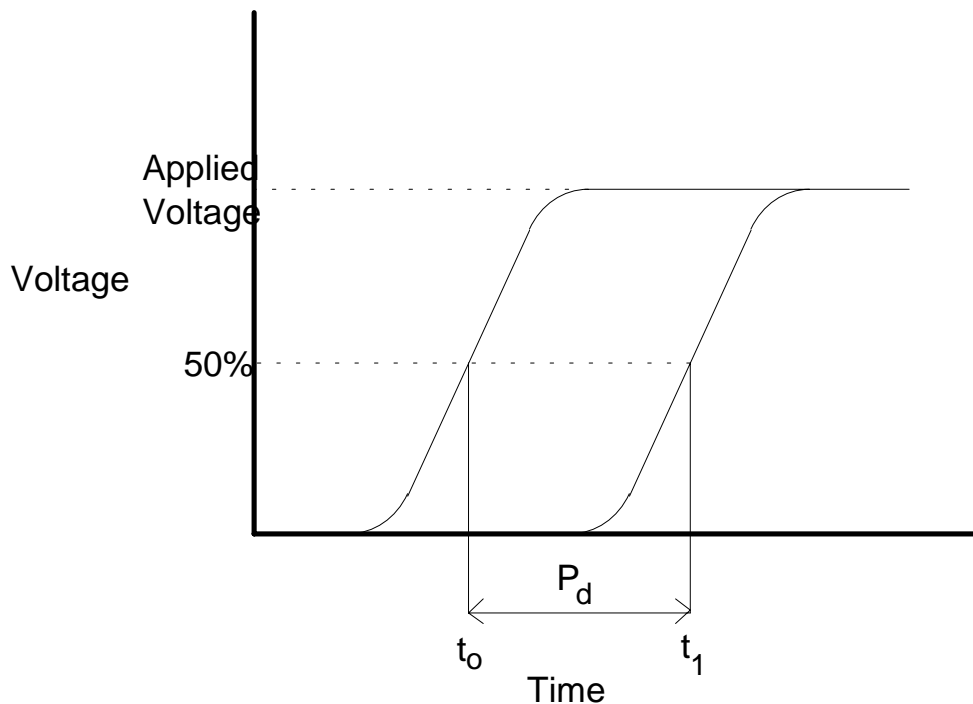

Figure 3 - Propagation time measurements

Use the TDR to measure the propagation time. Capture the input signal at the receiver and store in the instrument memory. Connect the cable assembly and capture the output signal.

The cable propagation delay will be determined by establishing the difference between t_0 and t_1 (See fig. 3). This will yield the cable delay performance.

Test conditions

A Time Domain Transmission system (TDT) is used both as the source of the test signal and as a means of measuring the propagation delay of the system.

Two precision coax cables whose characteristic impedance matches the impedance of the TDT system, are used to connect the test fixture to the TDT system.

The combined test system/fixture step response time should be equal to or less than the cable step response time.

Crosstalk:

This test will evaluate the cross talk performance for differential pairs of SCSI cable assemblies.

Test Conditions:

Source Signal: 504 mV p-p differential
 Source Resistance: 100 ohms differential matched to 122 ohm board trace split differential.
 Termination Resistance: 122 ohms split differential
 Signal risetime: 500 psec. (20 - 80%)
 S:G Ratio based on SPI-4 pin-out
 Tek 11801C Scope
 Proprietary designed test fixture boards, impedance controlled 61 ohm
 Single ended.
 Impedance matched risetime filters

Test Data Presentation:

Impedance Ohms (risetime: 500 ps)				
Data Lines	Round Cable	Twist/Flat	Twist Only	Comments
DB12				
DB13				
ACK				
REQ				
DB10				
DB11				

Attenuation Round Cable DB/m					
Data Lines	3 dB BW (MHz)	80 MHz	160 MHz	200 MHz	320 MHz
DB12					
DB13					
ACK					
REQ					
DB10					
DB11					

Attenuation Twist/Flat DB/m					
Data Lines	3 dB BW (MHz)	80 MHz	160 MHz	200 MHz	320 MHz
DB12					
DB13					
ACK					
REQ					
DB10					
DB11					

Attenuation Twist Only DB/m					
Data Lines	3 dB BW (MHz)	80 MHz	160 MHz	200 MHz	320 MHz
DB12					
DB13					
ACK					
REQ					
DB10					
DB11					

Propagation Time Round Cable (ns)				
Differential Pair	Conductor 1	Conductor 2	Propagation Time	Propagation Time/Meter
DB(12)	1	35		
DB(13)	2	36		
ACK	24	58		
REQ	29	63		
DB(10)	33	67		
DB(11)	34	68		

Propagation Time Twist/Flat (ns)				
Data Line	Conductor 1	Conductor 2	Propagation Time	Propagation Time/Meter
DB(12)	1	35		
DB(13)	2	36		
ACK	24	58		
REQ	29	63		
DB(10)	33	67		
DB(11)	34	68		

Propagation Time Twist Only (ns)				
Data Line	Conductor 1	Conductor 2	Propagation Time	Propagation Time/Meter
DB(12)	1	35		
DB(13)	2	36		
ACK	24	58		
REQ	29	63		
DB(10)	33	67		
DB(11)	34	68		

Cross Talk (Differential) Rise time (20-80%): 500 ps							
Differential Pair		Round Cable		Twist/Flat		Twist Only	
Driven	Victim	NEXT %	FEXT %	NEXT %	FEXT %	NEXT %	FEXT %
24, 58	29, 63						
1, 35	2, 36						

Bob Gannon agreed to attempt to define a signal degradation test based on eye diagrams and with independent aggressor signals operating during the acquisition of the primary pair under test eye.

11.5 Frequency dependence of dielectric constant test methodology round robin - Barnes, LSI Logic; Vaupotic, Spectra strip

Deferred (again) to some indeterminate future time due to the departure of Larry Barnes from LSI Logic.

This work is intended to use the HP polished probe method according to the following table. A round robin is planned when the method is stabilized.

Greg Vaupotic provided swept frequency data from the slab method for several samples. The samples in both pellet and extruded form along with data were provided to Larry B.

This discussion produced collaboration containing the following:

Pure polyethylene samples to be provided by Spectra Strip (unlikely to be affected by processing)	slab method data from Spectra Strip's supplier measurements	coax probe method from LSI Logic measurements
raw material processed into a slab	Spectra strip	NA due to slab samples no longer existing
raw material extruded over single conductor 30 AWG with approximately 10 mils dielectric thickness	NA	LSI logic -- strip material off conductor and measure by inserting the probe through slit in the conductor to the opposite side

The range of frequency will be at least 1 MHz to 1 GHz linear sweep.

The samples and slab data have been delivered to Larry.

Greg Vaupotic and Larry Barnes are actioned to complete the work outlined in the above table.

12. Proposed new round robins

No new round robins were proposed this meeting. See however, the next item.

13. PIP documentation - Daggett

13.1 Actions required to produce a ballotable PIP document, group

Discussion about how to produce a ballotable PIP document was again undertaken. A serious push is being mounted to get the document completed within the next couple of months. Larry Barnes has been doing some editing in his spare time - Thanks Larry.

Enough material has been gathered to enable creation of a credible document but some paring needs to happen. Editing sessions were scheduled at two week intervals for the next six weeks. See section on meeting schedule for details.

At the next meeting specific section of the document will be assigned to individual editors. A number of people have indicated willingness to help so there now a better chance of getting the document finished.

13.2 Definitions for the document - Barnes

Not addressed at this meeting.

13.3 Conversion of the document into Frame from Word.

Thanks to Larry Barnes and Bill Ham the existing revision of PIP and the new material from the minutes was completely converted into Frame 6.0 at the December meeting. Since then significant work has been completed on the conversion. The remaining conversions needed are a few figures that Bill Ham will complete before the next editing session.

13.4 Report from last editors meeting

Not done due to lack of time.

13.5 Document review, Zane

Not done due to lack of time.

14. Old business

14.1 Skew measurement and specification methodology, Ham

This topic was not discussed in February and may be deleted from future agendas in the interest of getting the document finished.

15. New business

15.1 SSDB position for PIP

The PIP methodology for interconnect assemblies depends critically on having an SSDB for producing the signals. With the departure of Larry Barnes from LSI Logic it is not clear whether LSI Logic will actually supply an SSDB to the industry. Seagate indicated that they are willing to supply an SSDB if needed. Therefore, since PIP needs to have a working framework the following motion was formally made:

Motion, Ham/Daggett, that PIP will be developed with the assumption that an SSDB will be available to use with the measurements that require it.

Motion passes unanimously.

16. Next meetings

PIP is always scheduled in conjunction with SSM-x. An editing session is always included for one or the other project. PIP and SSM alternate in terms of which is first and which is second. The editing day is either before or after the contiguous PIP/SSM days and is identified in the schedule. To get this started SSM precedes PIP in February 2002, PIP precedes SSM in April 2002, etc.

Approved schedule:

March 8, 2002 (Fri) 7AM to noon, Hitachi plant, Manchester, NH (editing)

March 18, 2002 (Mon) 9AM to 5PM, Compaq plant, Shrewsbury, MA (editing)

April 2, 3, 2002 (Tues) 9AM to 5PM, New Hampshire, (Hitachi) - (04/03 is editing for PIP, 04/04 is SSM)

[Additional editing meetings are expected in April and May]

Requested schedule:

June 20, 2002 Lisle, IL (Molex) - (06/18 is editing for SSM, 06/19 is SSM)

Aug 13 Southern CA (Actuone - parent to Foxconn) 13 PIP editing, 14 pip
15 SSM

October 15, 2002 Worcester MA (Madison) 15 SSM editing, 16 SSM, 17 SSM
editing

December 03, 2002 Guadalajara, Jalisco, MX (Electronica Pantera) 03 PIP
editing, 04 PIP, 05 SSM

17. Action Items:

17.1 Old action items from previous meetings

Larry Barnes to acquire data from the polished coax probe method for dielectric constant frequency variations.

Status: action cannot be completed by Larry due to his departure from LSI Logic. The equipment still resides at LSI Logic and this action depends on the availability of the equipment. Contact VP of storage components division, Bill Weurtz LSI Logic Colorado Springs for information on how this action can be completed.

Zane to provide a methodology specification for the HP slab method for dielectric constant vs. frequency

Status: no change -- still approx 50% complete

Bill Ham to post the draft minutes to the T10 web site

Status: done 02-019r0

Umesh to propose a set of tests to be used including things like test fixtures and specific slots to be measured for backplane round robin 1.

Status: done - except for S21 tests - Bruce M to expedite (a new action item was assigned to address the S21 issues - this item is completed and will be removed from future minutes)

Ham to deliver a single 10 slot Compaq backplane (one that is presently shipping) for backplane round robin 1.

Status: overcome by events

Greg Vaupotic and Larry Barnes to complete the work outlined in the table relating to the frequency dependence of dielectric constant.

Status: slab method data and samples sent to Larry - still need the probe method measurements - Greg's part is done - goes into the Larry Barnes bucket

Larry Barnes to place his spreadsheet relating to effects of periodic structures on the T10 web site.

Status: file has been recovered from an older rev - posting expected soon

Greg V to create 01-130r1 containing the essence of the Seagate results relating to effects of sample length on impedance.

Status: carried over

Ham to create a draft of the overview section for the PIP document

Status: significantly progressed - needs review

Larry Barnes to contact Bob Christopher again to determine probable future involvement of Bill Troop

Status: Bill is able to continue involvement as long as travel is not required - use of electronic meeting tools, e.g. Placeware, will enable Bill's participation - Seagate and LSI Logic to attempt to provide this capability for the February 2002 meeting. Since this capability depends on the internal LSI Logic infrastructure this item is effectively overcome by events.

Zane to draft a letter to LSI Logic containing the material developed by PIP relating to SSDB's

Status: done - has been forwarded within LSI Logic - favorable response so far - availability expected Q2/Q3 can go to U640 speed.

Larry Barnes to ask for a written response to Zane's letter relating to the SSDB.

Status: done - no response yet received -- Zane to follow up

Larry presented approximately 20 sources of material that relate to PIP measurements. Larry is actioned to combine these files into a single file and post on the T10 site. Folks are encouraged to look at these references and determine if any content is relevant to the PIP project.

Status: non-copyrighted material was posted -- Larry will provide his original list (in whatever form it exists).

Status: carried over

17.2 New actions from this meeting

Bill Ham to post the minutes to the T10 web site

Status: new

Action to chair to contact Bill Weurtz of LSI Logic to determine future activity on action items previously assigned to Larry Barnes

Status: new

Umesh to propose a set of tests to be for backplane S21 measurements.

Status: new

18. Adjourn

The meeting adjourned at 12:30PM on December 12, 2001