

## Comment Resolution Status

Document: T10/01-328r8

Date: 2 July 2002

To: T10 Committee Membership  
From: Cris Simpson, Intel Corporation  
Subject: Response to T10 Letter Ballot comments on SRP

This document does not contain **T10/1415-D revision 16**, the SRP Working Draft. It should be available at <ftp://ftp.t10.org/t10/drafts/srp/srp-r16.pdf>

### Comments with possible implementation effects (list may be incomplete):

HP09: Security Protocol	Rejected
HP27: Identifier construction rules	Closed
IBTA: IOControllerProfile I/O Class field	Closed
OD 3: Cross-channel reporting	Rejected/Defer
OD 4: Swap GUID and Extension fields in Port Identifiers	Closed
OD6: Solicited Events	Closed
OD 8: Buffer formats & codes	Rejected
Disconnect/error handling	Closed
Troika: Correct Type Code in SRP_LOGIN_REJ	Closed

## Table of Comments

**Brocade comments:**

Bro101	Rejected	07 Jan 2002	12
Bro102 page 70 line 13	Closed		12
Bro103 page xii line 3	Closed		12
Bro104 page xii line 8	Closed		12
Bro105 page xiii line 7	Closed		12
Bro106 page 1 line 6	Closed		12
Bro107 page 3 lines 32-35	Closed		13
Bro001	Closed		13
Bro002 page 62 lines 22-23	Rejected	28 Nov 2001	13
Bro003 page 62 lines 39-40	Closed		14
Bro004 page 65 line 50	Closed		14
Bro005 page 65 lines 16-17	Closed		14
Bro006 page 66 lines 23-48	Closed		15
Bro007 page 67 line 16	Closed		16
Bro008 page 67	Closed		17
Bro009 page 67 lines 48-49h	Closed		17
Bro010 page 67 lines 48-49	Closed		17
Bro011 page 67 lines 13-14	Closed		17
Bro012 page 72 line 1	Closed		18
Bro013 page 72 lines 4-5	Closed		18

**Compaq comments:**

CPQ001a page i	Closed		19
CPQ001b page i	Rejected	28 Nov 2001	19
CPQ002	Rejected	28 Nov 2001	19
CPQ003 page iii line 1	Rejected	28 Nov 2001	19
CPQ004 page 1 lines 21-24, page 2 line 25, page 3 lines 19-21	Closed		19
CPQ005 page 1 line 3	Closed		19
CPQ006a page 4 line 9	Rejected	07 Jan 2002	19
CPQ006b page 5 line 4	Closed		19
CPQ007 page 16 lines 28-31	Closed		20
CPQ008 page 19	Closed		20
CPQ009 page 19 line 32	Closed		20
CPQ010 page 19 line 36	Closed		21
CPQ011 page 20 line 43 to page 21 line 3	Rejected	07 Jan 2002	21
CPQ012 page 21 line 30	Closed		21
CPQ013 page 21 line 26	Rejected	07 Jan 2002	21
CPQ014 page 28 line 41	Closed		22
CPQ015 page 28 lines 13-16	Rejected		22
CPQ016 page 28 line 24	Closed		22
CPQ017 page 29 line 10	Closed		22
CPQ018 page 30 line 40 and page 30 line 44	Closed		22
CPQ019 page 33 line 46	Closed		22
CPQ020 page 32 line 24	Closed		23
CPQ021 page 36 lines 24-42	Rejected	07 Jan 2002	23
CPQ022 page 37 and page 38	Closed		23
CPQ023 page 38 lines 8-17	Rejected	07 Jan 2002	23
CPQ024 page 38	Closed		23

CPQ025 page 38 line 5	Closed	23
CPQ026 page 39 lines 38-44	Rejected .. 07 Jan 2002	23
CPQ027 page 39 line 45 and page 39 line 48	Closed	24
CPQ028 page 40 lines 20-36	Closed	24
CPQ029 page 40 line 33	Closed	24
CPQ030 page 40 line 20	Closed	24
CPQ031 page 44 line 7	Rejected .. 07 Jan 2002	24
CPQ032 page 45 line 32	Rejected .. 07 Jan 2002	24
CPQ033 page 45 lines 30-34	Rejected .. 07 Jan 2002	24
CPQ034 page 48 line 3	Rejected .. 07 Jan 2002	25
CPQ035 page 48 line 3	Closed	25
CPQ036 page 49 lines 3-8	Rejected .. 07 Jan 2002	25
CPQ037 page 52 line 15 and page 53 line 23	Rejected .. 07 Jan 2002	25
CPQ038 Annex B	Closed	25
CPQ039	Closed	25
CPQ040 Annex C	Closed	26

**HP comments:**

HP01 page 56	Closed	27
HP02	Rejected .. Not reviewed	27
HP03 page 1	Closed	27
HP04 page 1	Closed	28
HP05 Page 2 Line 28	Rejected/Defer	28
HP06 page 8	Closed	28
HP07 page 8	Closed	28
HP08 Page 8 Line 20	Rejected	29
HP09 Page 10 Line 12	Rejected	29
HP10 page 11	Closed	29
HP11 Page 12 Line 40	Rejected	29
HP12	Closed	29
HP13 Page 15 Line 24	Rejected	29
HP14 Page 16 Line 28	Rejected	30
HP15 Page 20 Line 4	Rejected	30
HP16 page 28	Rejected/Defer	30
HP17 Page 25 Line 1	Rejected	30
HP18 Page 25 Line 32	Rejected	31
HP19 Page 25 Line 32	Rejected	31
HP20 Page 54 Line 1	Rejected	31
HP21 Page 54 Line 23	Rejected	31
HP22 Page 54 Line 28	Rejected	31
HP23 Page 54 Line 28	Rejected	31
HP24 Page 54 Line 28	Rejected	32
HP25 Page 55 Line 9	Closed	32
HP26 page 66	Closed	32
HP27 page 66, page 16	Closed	32

**IBM / Tivoli comments:**

IBM001 page i to page iv	Rejected .. Not reviewed	34
IBM002 page iii	Rejected .. Not reviewed	34
IBM003 page iii	Rejected .. Not reviewed	34
IBM004 page iii	Rejected .. Not reviewed	34

IBM005 page xii line 3	Closed	34
IBM006 page xiii line 7	Closed	34
IBM007	Rejected	Not reviewed
IBM008a page 1 line 47, page 1 line 2	Rejected	Not reviewed
IBM008b page 2 line 4	Rejected	Not reviewed
IBM008c page 2 line 10, page 2 line 20, page 2 line 31	Rejected	Not reviewed
IBM008d page 3 line 8	Closed	35
IBM009 page 4 lines 4-6	Rejected	Not reviewed
IBM010	Rejected	Not reviewed
IBM011 page 4 line 19	Closed	35
IBM012 page 4	Closed	36
IBM013 PDF Page 16	Rejected	36
IBM014 PDF Page 16	Closed	36
IBM015 PDF Page 16	Closed	36
IBM016 PDF Page 17	Closed	36
IBM017 PDF Page 17	Closed	37
IBM018 page 8	Closed	37
IBM019 page 8	Closed	37
IBM020 page 8	Closed	37
IBM021 page 10	Closed	37
IBM022 page 9	Closed	37
IBM023 page 9	Closed	37
IBM024 page 9	Closed	37
IBM025 page 10	Closed	38
IBM026 page 10	Closed	38
IBM027 page 10	Closed	38
IBM028 page 10	Closed	38
IBM029 page 10	Closed	38
IBM030 page 10	Closed	38
IBM031 page 11	Closed	39
IBM032 page 10	Closed	39
IBM033 page 11	Closed	39
IBM034 page 11	Closed	39
IBM035 page 11	Closed	39
IBM036 page 12	Closed	39
IBM037 page 12	Closed	39
IBM038 page 12	Closed	39
IBM039 page 12	Closed	40
IBM040 page 13	Rejected	40
IBM041 page 13	Closed	40
IBM042 page 13	Closed	40
IBM043 page 12	Rejected	40
IBM044 page 13	Closed	40
IBM045 page 14	Closed	40
IBM046 page 14	Closed	40
IBM047 page 14	Closed	41
IBM048 page 15	Closed	41
IBM049 page 13, page 15	Closed	41
IBM050 PDF page 16	Closed	41
IBM051 page 14	Closed	41
IBM052 page 15	Closed	41
IBM053 page 15	Closed	42
IBM054 page 16	Closed	42
IBM055 page 16	Closed	42

IBM056 PDF Page 28	Closed	42
IBM057 PDF page 16	Closed	42
IBM058 PDF page 16	Closed	42
IBM059 page 16	Closed	42
IBM060 page 16	Rejected	42
IBM061 page 16	Closed	42
IBM062 page 17	Closed	42
IBM063 PDF Page 28	Closed	43
IBM064 page 17	Closed	43
IBM065 page 16	Closed	43
IBM066 page 18	Closed	43
IBM067 page 18	Closed	43
IBM068	Closed	43
IBM069	Closed	44
IBM070	Rejected	44
IBM071 page 19	Closed	44
IBM072 PDF Page 30	Rejected	44
IBM073 PDF page 19	Closed	44
IBM074 PDF Page 30	Closed	44
IBM075 PDF Page 30	Closed	44
IBM076 page 19	Closed	44
IBM077 page 19	Closed	45
IBM078 page 20	Closed	45
IBM079 page 20	Closed	45
IBM080 page 19	Closed	45
IBM081 page 20	Closed	45
IBM082 page 20	Closed	45
IBM083 page 20	Closed	45
IBM084 page 20, page 20	Closed	45
IBM085 page 20	Closed	46
IBM086 PDF page 20	Closed	46
IBM087 page 21 , page 36	Closed	46
IBM088 page 20	Closed	46
IBM089 PDF Page 32	Closed	46
IBM090 page 21	Closed	46
IBM091	Closed	47
IBM092 page 21	Closed	47
IBM093 page 22	Closed	47
IBM094 page 22	Closed	47
IBM095 page 22	Closed	47
IBM096 page 22	Closed	47
IBM097 page 19	Closed	47
IBM098 page 17, page 23	Closed	48
IBM099 page 27	Closed	48
IBM0100	Rejected	48
IBM0101 page 28	Closed	48
IBM0102 page 28	Closed	48
IBM0103 PDF Page 38	Closed	48
IBM0104 page 29	Closed	48
IBM0105 PDF Page 39	Rejected	49
IBM0106 page 31	Closed	49
IBM0107 page 31	Closed	49
IBM0108 PDF Page 42	Closed	49
IBM0109 PDF Page 43	Closed	49

IBM0110 PDF Page 44	Closed	49
IBM0111 PDF Page 46	Rejected	49
IBM0112 page 40	Closed	49
IBM0113 PDF Page 46	Closed	50
IBM0114 PDF Page 48	Rejected	50
IBM0115 page 42	Closed	50
IBM0116 page 43, et al.	Closed	50
IBM0117 page 44	Closed	50
IBM0118 page 44	Closed	50
IBM0119 page 44	Closed	50
IBM0120 page 44	Closed	50
IBM0121 page 44	Closed	51
IBM0122 page 45	Closed	51
IBM0123 page 45	Closed	51
IBM0124 page 45	Closed	51
IBM0125 page 48	Closed	51
IBM0126 page 49	Closed	51
IBM0127	Closed	52
IBM0128 page 53	Closed	52
IBM0129	Closed	52
IBM0130 page 55	Closed	52
IBM0131 page 62	Closed	52
IBM0132 page 62	Closed	52
IBM0133 PDF Page 65	Closed	52
IBM0134 PDF page 63	Closed	52
IBM0135 PDF Page 67	Closed	52
IBM0136 page 66	Closed	53
IBM0137 page 67	Closed	53
IBM0138 page 67	Closed	53
IBM0139 PDF Page 68	Closed	53
IBM0140 page 67	Closed	53
IBM0141 page 67	Closed	53
IBM0142 page 67	Closed	53
IBM0143 PDF Page 68	Closed	53
IBM0144	Closed	53
IBM0145 page 68	Closed	54
IBM0146 page 68	Closed	54
IBM0147 page 72	Closed	54
IBM0148	Rejected	54
IBM0149 page 59	Closed	54
IBM0150	Closed	54
IBM0151	Closed	54
IBM0152	Closed	54

**InfiniBand™ Trade Association comment:**

IBTA page 71	Closed	55
--------------	--------	----

**Ophidian Designs comments:**

OD1 page 13	Closed	56
OD2 page 13	Closed	56
OD3	Rejected/Defer	56

OD4 page 66 tables B.2 and page 67 B.3	Closed	57
OD 5 Pages 4 and 5,	Rejected/Defer	58
OD6 Page 11 lines 20-22	Closed	58
OD 7	Rejected	28 Nov 2001 59
OD 8 page 19,	Rejected	60

**Intel comments:**

intel0001 Sect:1 page 1	Closed	61
intel0002 Sect:1 page 1	Closed	61
intel0003 page 4	Closed	61
intel0004 page 4	Rejected	61
intel0005 page 4	Closed	61
intel0006 page 4	Rejected	61
intel0007 page 4	Closed	61
intel0008 page 4 (C)	Closed	61
intel0009 page 5	Closed	62
intel0010 page 5 (C)	Closed	62
intel0011 page 5	Closed	62
intel0012 Sect:3.3.9 page 6	Closed	62
intel0013 page 8 , page 10, (C)	Closed	62
intel0014 page 9	Closed	62
intel0015 page 9 (C)	Closed	62
intel0016 page 9	Closed	62
intel0017 page 9	Rejected	63
intel0018 page 10 (C)	Rejected	63
intel0019 page 10	Closed	63
intel0020 page 10	Rejected	63
intel0021 page 10	Closed	63
intel0022 page 10, page 11	Closed	63
intel0023 page 11	Closed	63
intel0024 page 10	Rejected	63
intel0025 page 11	Rejected	64
intel0026 page 4 , page 11	Closed	64
intel0027 page 11	Closed	64
intel0028 page 11	Closed	64
intel0029 page 11	Closed	64
intel0030 page 11, page 10, page 12, page 15	Closed	64
intel0031 page 11	Closed	64
intel0032 page 11	Closed	64
intel0033 page 11	Closed	64
intel0034 page 11	Closed	64
intel0035 page 11	Rejected	65
intel0036 page 12 (C)	Closed	65
intel0037 page 13	Closed	65
intel0038 page 13	Closed	65
intel0039 page 14	Closed	65
intel0040 page 14	Closed	65
intel0041 Sect:5.1.1 page 15	Closed	65
intel0042 Sect:5.1.1 page 15	Rejected	65
intel0043 page 14	Closed	66
intel0044 Sect:5.1.3 page 14, page 33	Closed	66
intel0045 Sect:5.1.3 page 15	Closed	66

intel0046 page 15	Closed	66
intel0047 page 16	Closed	66
intel0048 page 16	Closed	66
intel0049 page 17 (C)	Closed	66
intel0050 page 17 (C)	Rejected	66
intel0051 page 17 (C)	Closed	67
intel0052 page 17 (C)	Closed	67
intel0053 page 17 (C)	Closed	67
intel0054 page 17	Closed	67
intel0055 page 17 (c)	Closed	67
intel0056 page 18	Rejected	68
intel0057 Sect:5.4.1 page 18	Rejected	68
intel0058 page 68	Closed	68
intel0059 page 18	Closed	68
intel0060 page 19	Closed	68
intel0061 page 19	Closed	68
intel0062 page 19	Closed	68
intel0063 page 19	Closed	68
intel0064 page 19 , page 20, page 21 (C)	Closed	69
intel0065 page 19	Closed	69
intel0066 page 19	Closed	69
intel0067 page 19	Closed	69
intel0067a page 19	Rejected	69
intel0068 page 20	Closed	69
intel0069 page 20	Closed	69
intel0070 page 20	Closed	69
intel0071 page 20	Closed	70
intel0072 Sect:5.4.2.2 Pg:19 Ln:18	Rejected	70
intel0073 page 20	Closed	70
intel0074 page 21	Closed	70
intel0075 page 21	Closed	70
intel0076 page 21	Rejected	70
intel0077 page 21	Closed	70
intel0078 page 21	Rejected	70
intel0079 page 21	Closed	70
intel0080 page 21	Closed	71
intel0081 page 21	Closed	71
intel0082 page 21	Closed	71
intel0083	Rejected	71
intel0084 page 22	Rejected	71
intel0085	Closed	71
intel0086	Closed	71
intel0087 page 21	Rejected	71
intel0088	Closed	71
intel0089 page 22	Closed	72
intel0090 page 22	Closed	72
intel0091 page 22	Closed	72
intel0092 page 23	Closed	72
intel0093	Closed	72
intel0094 Sect:6.1 page 26, page 46, page 48, page 50	Closed	72
intel0095 Sect:6.1 Pg:23 Ln:24	Closed	72
intel0096 Sect:6.1 page 27, page 36	Closed	72
intel0097 page 27	Closed	72
intel0098 page 27 (C)	Closed	73



intel0099 page 28 . . . . .	Closed . . . . .	73
intel0100 Sect:6.2 Pg:24 Ln:41 . . . . .	Closed . . . . .	73
intel0101 Sect:6.3 Pg:27 Ln:4 . . . . .	Closed . . . . .	73
intel0102 Sect:6.3 Pg:27 Ln:40 . . . . .	Closed . . . . .	73
intel0103 page 26, page 30 (C) . . . . .	Closed . . . . .	73
intel0104 Sect:6.4 Pg:29 Ln:3 . . . . .	Closed . . . . .	73
intel0105 page 33 . . . . .	Closed . . . . .	73
intel0106 page 34 . . . . .	Closed . . . . .	74
intel0107 page 35 (C) . . . . .	Rejected . . . . .	74
intel0108 page 36 . . . . .	Rejected . . . . .	74
intel0109 page 36 . . . . .	Closed . . . . .	74
intel0110 Sect:6.8 Pg:34 Ln:14 . . . . .	Rejected . . . . .	74
intel0111 page 39 . . . . .	Closed . . . . .	74
intel0112 Sect:6.9 Pg:36 Ln:36 . . . . .	Rejected . . . . .	74
intel0113 page 44, page 45 . . . . .	Closed . . . . .	74
intel0114 page 43 . . . . .	Closed . . . . .	74
intel0115 Sect:6.9 Pg:37 Ln:26 . . . . .	Rejected . . . . .	75
intel0116 Sect:6.9 Pg:37 Ln:26 (C) . . . . .	Rejected . . . . .	75
intel0117 page 44 . . . . .	Closed . . . . .	75
intel0118 Sect:6.9 Pg:38 Ln:17 . . . . .	Closed . . . . .	75
intel0119 page 44 . . . . .	Closed . . . . .	75
intel0120 page 44 . . . . .	Closed . . . . .	75
intel0121 page 45 . . . . .	Closed . . . . .	75
intel0122 Sect:6.9 Pg:39 Ln:1 . . . . .	Rejected . . . . .	75
intel0123 Sect:6.9 Pg:39 Ln:18 . . . . .	Closed . . . . .	75
intel0124 Sect:6.9 Pg:39 Ln:31 . . . . .	Rejected . . . . .	75
intel0125 Sect:6.9 Pg:39 Ln:33 . . . . .	Rejected . . . . .	76
intel0126 Sect:6.9 Pg:39 Ln:30 . . . . .	Rejected . . . . .	76
intel0127 Sect:6.11 Pg:40 Ln:43 (c) . . . . .	Closed . . . . .	76
intel0128 Sect:6.12 Pg:41 Ln:31 . . . . .	Rejected . . . . .	76
intel0129 Sect:6.12 Pg:41 Ln:43 . . . . .	Rejected . . . . .	76
intel0130 page 49 (C) . . . . .	Closed . . . . .	76
intel0131 Sect:6.12 Pg:42 Ln:1 . . . . .	Rejected . . . . .	76
intel0132 Sect:6.12 Pg:42 Ln:7 . . . . .	Rejected . . . . .	76
intel0133 page 52 . . . . .	Closed . . . . .	76
intel0134 Sect:7.2 page 52 . . . . .	Closed . . . . .	76
intel0135 Sect:7.2 Pg:44 Ln:1 . . . . .	Closed . . . . .	77
intel0136 . . . . .	Rejected . . . . .	77
intel0137 . . . . .	Closed . . . . .	77
intel0138 page 53 . . . . .	Closed . . . . .	77
intel0139 page 53 . . . . .	Closed . . . . .	77
intel0140 Sect:7.2 Pg:44 Ln:24 . . . . .	Rejected . . . . .	77
intel0141 Sect:7.2 Pg:44 Ln:24 . . . . .	Rejected . . . . .	77
intel0142 page 53 . . . . .	Closed . . . . .	77
intel0143 Sect:A.1 Pg:45 Ln:11 . . . . .	Closed . . . . .	77
intel0144 page 54 . . . . .	Closed . . . . .	78
intel0145 page 55 . . . . .	Closed . . . . .	78
intel0146 Fig A.3 . . . . .	Closed . . . . .	78
intel0147 page 56 . . . . .	Closed . . . . .	78
intel0148 Sect:A.4.1 Pg:48 Ln:44 . . . . .	Closed . . . . .	78
intel0149 page 62 . . . . .	Closed . . . . .	78
intel0150 page 62 . . . . .	Closed . . . . .	78
intel0151 page 62 . . . . .	Closed . . . . .	78
intel0152 page 63 . . . . .	Closed . . . . .	78

intel0153 page 63	Closed	78
intel0154 Sect:B.4 Pg:54 Ln:50 (C)	Closed	78
intel0155 Sect:B.4 Pg:55 Ln:17	Closed	79
intel0156 page 66	Closed	79
intel0157	Closed	79
intel0158 page 66	Rejected	79
intel0159	Closed	79
intel0160 page 66	Closed	79
intel0161 page 67	Closed	79
intel0162	Closed	79
intel0163 page 67	Closed	80
intel0164 page 68	Closed	80
intel0165 page 68	Closed	80
intel0166	Closed	80
intel0167 page 68	Closed	80
intel0168 page 68	Closed	80
intel0169	Closed	80
intel0170 page 69	Closed	80
intel0171 Sect:B.7 Pg:58 Ln:37	Closed	80
intel0172	Closed	80
intel0173 Sect:B.7 Pg:60 Ln:23 (c)	Rejected	81
intel0174 Sect:B.7 page 71 Ln:24 (c)	Closed	81
intel0175 Sect:B.7 page 71 Ln:26 (c)	Closed	81
intel0176 Sect:B.7 page 71 Ln:46 (c)	Closed	81
intel0177 page 72	Closed	81
intel0178 page 72	Rejected	81
intel0179 page 72	Closed	81

**Texas Instruments comment:**

**Troika Networks comment:**

Troika Networks, Inc.: page 32	Closed	83
--------------------------------	--------	----

**Woven Electronics comment:**

Woven Electronics:	Rejected	84
--------------------	----------	----

**New editor comments:**

edit001 page 62	Closed	85
edit002 page 70, page 71	Closed	85
edit003 page 65	Closed	85
edit004 page 66	Closed	85
edit005 page 16	Closed	85
edit006 page 45	Closed	85
edit007 page 43 , page 43, page 49, page 49	Closed	86
edit008 page 15	Rejected	86
edit009	Rejected	86
edit010 page 19	Closed	86
edit011 page 20 C	Closed	86
edit012 page 13	Closed	86

edit013 page 13	Closed	86
edit014 page 5	Closed	87
edit015 page 55	Closed	87
edit016 page 35, page 43, page 43, page 46, page 48	Closed	87
edit017 page 71	Closed	87
edit018 , page 26, page 34	Closed	87
edit019 page 36	Closed	87
edit020 page 4,	Closed	88
edit021 page 53	Closed	88
edit022 page 54	Closed	88
edit023 page 16	Closed	88
edit024 page 62, page 62	Closed	88
edit025 page 68	Closed	88
edit026 page 63	Closed	88
edit027 page 67	Closed	88
edit028 page 72	Closed	88
edit029 page 62	Closed	89
edit030 page 13	Closed	89
edit031 page 11	Closed	89
edit032 page 27	Closed	89
edit033 page 20	Closed	89
edit034 page 59	Closed	89
edit035 page 12	Closed	90
edit036 page 13	Closed	90
edit037 page 14	Closed	90
edit038 page 15	Closed	90
edit039 page 52	Closed	90
edit040 page 14, page 15	Closed	90

**Brocade comments:****Bro101****Rejected 07 Jan 2002**

The word 'which' is used inappropriately in many places. Suggested Solution: Do a global search for the word which and replace it with one of the following corrections: A) the word 'that'. B) a new sentence construction that does not require the word. C) nothing. (Which can simply be removed in many cases.)

All occurrences of "which" are correct both grammatically and according to the Chicago Manual of Style.

**Bro102 page 70 line 13****Closed**

The word 'must' is used inappropriately. Suggested Solution: The line 'At least one IB I/O controller must be present' should be replaced. I am not sure if this is a requirement that at one or more controllers shall be present. If so, wording like 'At least one IB I/O controller shall be present' is appropriate.

Proposed text:

At least one IB I/O controller acting as an SRP target port shall ~~must~~ be present.

**Bro103 page xii line 3****Closed**

X3.269 is not the proper name Suggested Solution: This value is not correct and should be marked as TBD or XXX or something like that. In any case, it is an NCITS document, not an X3 document.

IBM005 See IBM005. Proposed text:

This foreword is not part of American National Standard NCITS.\*\*\*:200x ~~X3.269-199x~~.

**Bro104 page xii line 8****Closed**

"by National' s/b 'by the National'" Suggested Solution: Correct as requested.

Insert "the" as requested.

**Bro105 page xiii line 7****Closed**

*CRS: Agree w/ comment. Added 'Working Draft' note to Master Page - s/b sufficiently clear, allow correcting text.*

"The working draft SCSI' s/b 'The SCSI'" Suggested Solution: This correction should be made now, even though the document is still a working draft, because it is clearly labeled in lots of places that it is a draft, but the text in it is intended to be the content of the standard.

IBM006 The document is a working draft until it is published by ANSI or NCITS. NCITS requires that we prominently label it a "working draft" until then. See IBM006.

**Bro106 page 1 line 6****Closed**

*Accepted.*

"The working draft SCSI' s/b 'The SCSI'" Suggested Solution: This correction should be made now, even though the document is still a working draft, because it is clearly labeled in lots of places that it is a draft, but the text in it is intended to be the content of the standard.

The document is a working draft until it is published by ANSI or NCITS. NCITS requires that we prominently label it a "working draft" until then.

**Bro107 page 3 lines 32-35**

**Closed**

*Accepted, corrected formats, added URL.*

Global Engineering should be included here as well, since the drafts are not available from ANSI or NCITS. Suggested Solution: Include Global Engineering as a document source. Include www.t10.org as a document source for standards in development.

The following note will be added to the end of sub-clause 2.3 (copied from sam4r07):

NOTE 1 - For more information on the current status of ~~a the~~ document, contact the NCITS Secretariat at 202-737-8888 (phone), 202-638-4922 (fax) or via Email at ncits@itic.org. To obtain copies of ~~these this~~ documents, contact Global Engineering at 15 Inverness Way, East Englewood, CO 80112-5704 at 303-792-2181 (phone), 800-854-7179 (phone), or 303-792-2192 (fax).

**Bro001**

**Closed**

The draft now seems to equate 'SRP target port' and 'IB service', so an SRP target port is designated by a ServiceID. This implies there can be many ports per IOC. This is a significant change from prior drafts where the target port was equated with an IOC, and there was just a single ServiceID per port. It requires a different model for software (OSs or whatever) to manage which hosts have access to which devices in a multi-host environment. Previously, access control was needed only to the level of IOCs, the draft now implies a need to manage not only who can use which IOCs, but which devices within an IOC. Suggested Solution: No solution required if interpretation is correct and implications are understood

*Accepted, no change requested.*

It is true that annex B equates an SRP target port to an IB service, with the caveat that "IB service" is not clearly defined by the IB specification. It is better to say that annex B equates an SRP target port to an IB service entry. Note that multiple SRP target ports (multiple IB service entries) could all use the identical ServiceID, with the particular SRP target port determined by the SRP target port identifier supplied during login.

The intent to allow many SRP target ports per IB I/O controller has been around for quite some time. The only new item in this draft was the specific mechanism for determining the extension field of the SRP target port identifier from the service name. That mechanism was agreed to at a teleconference in late September.

Note that access control is needed not just to IB I/O controllers and SRP target ports, but also to individual logical units. SCSI provides such access controls.

**Bro002 page 62 lines 22-23**

**Rejected 28 Nov 2001**

The definition of 'IB channel adapter GUID' implies it is the Node GUID but doesn't say so; might as well be explicit Suggested Solution: 'An IB Node GUID that uniquely identifies an IB channel adapter'

*EAG: The IB specification treats "channel adapter" and "node" as synonyms. However, use of "node" appears to have been denigrated, it only appears as the names of some attributes and components. For example, the definition of the NodeGUID component of the NodeInfo attribute is that it contains the GUID of a channel adapter, that is, a channel adapter GUID. The IB specification glossary defines channel adapter but does not define node.*

**Bro003 page 62 lines 39-40****Closed**

*Added: This value is present as the GUID attribute of the IOControllerProfile. (See Table B.7)*

The definition of 'IB I/O controller GUID' implies it is the IOControllerProfile GUID but doesn't say so; might as well be explicit Suggested Solution: 'An IB IOControllerProfile GUID that uniquely identifies an IB channel adapter'

The definition of IB I/O controller GUID is correct, the GUID value does identify the I/O controller. Replacing "I/O controller" with "IOControllerProfile" replaces a somewhat obscure term (I/O controller) with a confusing acronym (IOControllerProfile). For example, one natural interpretation of "IOControllerProfile GUID" is that it is an identifier of the IOControllerProfile attribute for use in protocol operations (e.g. MADs), not an identifier of the I/O controller. Also, the GUID value (whatever it is called) does not identify an IB channel adapter as stated in your suggested solution.

However, annex B does not state that the IB I/O controller GUID is the value reported in IOControllerProfile. Adding that would be a useful clarification. Proposed changes to [page 67](#) lines 36-37.

Proposed text:

The IO CONTROLLER GUID field ~~is shall be~~ the IB I/O controller GUID value that identifies ~~of~~ the IB I/O controller containing the SRP target port. This shall be the value reported in the GUID component of the IB I/O controller's IOControllerProfile attribute.

**Bro004 page 65 line 50****Closed**

IBM0135

IB GIDs can have link-local scope and thus may not be 'globally' unique Suggested Solution: Change to 'unique within a subnet', or 'either unique within a subnet or globally unique'

Current text:

Each IB port is assigned one or more 16-bit IB LIDs by the IB subnet manager. Each IB port has one or more 128-bit IB GIDs. Each IB GUID is globally unique, and may be formed in part from the IB port GUID. An IB GUID conforms to the format of an IPv6 address. The IB subnet manager provides a service to determine one or more IB LIDs and IB GIDs corresponding to an IB port GUID or IB channel adapter GUID.

*CRS: This text seems overly informative. How GIDs are formatted, formed, or resolved is not relevant to SRP - it just uses them.*

Proposed text:

*The IB subnet manager assigns one or more IB LIDs and one or more IB GIDs to each IB port.*

**Bro005 page 65 lines 16-17****Closed**

*(In Table B.1, GID row) replace 'worldwide' with 'varies' and a reference to the IB spec's Addressing chapter.*

IB GIDs can have link-local scope and thus may not be unique 'worldwide' Suggested Solution: Change 'worldwide' to 'IB subnet or worldwide'

**Bro006 page 66 lines 23-48****Closed**

Figure B.3's equating of 'SRP Target Ports' with 'IB consumers' is problematic. A 'target port' is a sort of service access point---somewhere where interested parties initially go to obtain service, but without any implication that that's where the service is actually provided. (In IB, it's the Connection Manager that receives the initial connection request, interprets the ServiceID contained therein, and performs some magic that results in the instantiation of a QP bound to some entity that actually provides the target services). This target-services-providing entity fits the definition of 'IB consumer'. But the mapping of ServiceIDs-cum-SRP target ports onto such entities is clearly a matter of implementation, and could be one-to-many, many-to-one, or many-to-many Suggested Solution: One possibility: to the left of the IB Consumers show a table/list of service IDs within each IB I/O unit and label these entries as SRP Target Ports; use arrows to show a mapping from the entries to the IB Consumers, with e.g. one Consumer mapped to two IDs and another mapped to one ID to show that the mappings are not always 1 to 1. A further refinement might be to use another set of arrow between the Consumers and the QPs to show that the this mapping is also not 1 to 1

This comment is correct, but it's not immediately obvious how to incorporate it into a legible diagram. Note the further complication introduced by connection redirection. The IB consumer (IB QP and the software, etc. behind it) may be in an unrelated device / node / whatever, it need not be the same channel adapter or even an I/O unit. The sole purpose of the I/O unit and I/O controller is to obtain a service ID, connecting to that service ID may lead somewhere else altogether.

Notes from 28 Nov 2001 teleconference: show service entries in figures B.2 and B.3, in accompanying text explain that each service entry identifies an SRP target port.

The following is an attempt at a modified figure B.2 and the text describing service entries that identify SRP target ports

An IB I/O unit is an InfiniBand™ Architecture device that contains an IB channel adapter with one or more IB ports, IB QPs, and one or more IB I/O controllers. Figure 0.1 shows an example IB I/O unit.

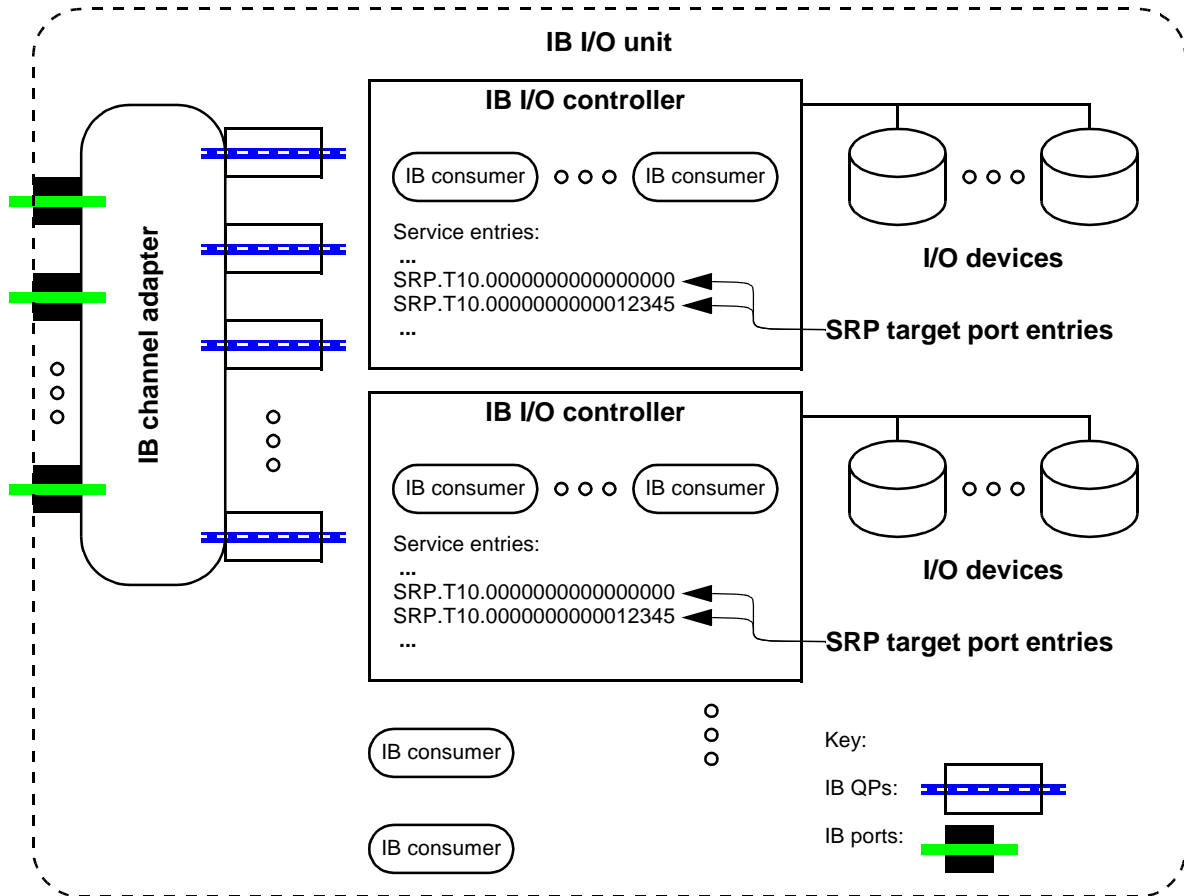

Figure 0.1 - IB I/O unit example

One or more service entries are associated with each IB I/O controller. A service entry contains a name and other information identifying an individual service provided by the IB I/O controller. A service entry may identify an SRP target port or a non-SRP service (e.g. a network interface service). Requirements for service entries that identify SRP target ports are described in table B.8.

Each IB port has a 64-bit globally unique identifier called an IB port GUID. Each IB channel adapter has a IB channel adapter GUID (which is shared by all IB ports on the IB channel adapter). Each IB I/O controller has an IB I/O controller GUID.

Bro007 page 67 line 16

Closed

Missing word Suggested Solution: 'used by the SRP initiator port'?

Proposed text:

The GUID field should an IB GUID available to the SRP initiator port, e.g. the IB channel adapter GUID for an IB channel adapter used by the SRP initiator port.



**Bro008 page 67****Closed**

Names of IB attributes are incomplete Suggested Solution: 'IOUnitInfo, IOControllerProfile, and ServiceEntries'

Proposed text:

SRP target ports shall be implemented \*\*\* in IB I/O units. The IB I/O unit shall include a device management agent to provide IOUnitInfo, IOControllerProfile, and ServiceEntries attributes ~~and make available an IB I/O controller GUID.~~

Note the IOControllerProfile attribute contains the I/O controller GUID, there is no need to call it out separately. Indeed, calling it out separately risks confusion that it is somehow different from the GUID component of the IOControllerProfile attribute.

\*\*\*Added "by IO Controllers".

**Bro009 page 67 lines 48-49h****Closed**

*Done across document.*

'I/O' is broken across lines (and pages) Suggested Solution: Make sure the slash in 'I/O' is non-breaking

**Bro010 page 67 lines 48-49****Closed**

The phrase 'processor unit or IB I/O controller' makes an incorrect distinction; target ports can only be found on IB I/O controllers by definition, whether or not the I/O controller embodies a processor unit Suggested Solution: Omit 'processor unit or'

Proposed text:

IB communications managers on each InfiniBand™ Architecture device manage InfiniBand™ Architecture connections using IB MADs transported over the IB general service interface. SRP initiator ports and SRP target ports shall use the active/passive (client/server) connection establishment protocol. The ~~processor unit or~~ IB I/O controller containing the SRP target port shall act as the server and the processor unit or IB I/O controller containing the SRP initiator port shall act as the client.

edit027

*Contain or provide?*

**Bro011 page 67 lines 13-14****Closed**

'IB I/O controllers acting as SRP target ports' could be construed as a 1-to-1 correspondence between controllers and target ports Suggested Solution: 'IB I/O controllers making SRP target ports available' or 'IB I/O controllers hosting SRP target ports'?

Proposed text:

edit027

The IB service ID associated with each matching service name may be used in the communication management process to open InfiniBand™ Architecture connections to ~~IB I/O controllers acting as an~~ SRP target ports. The SRP target port identifier for each SRP target port is constructed as described in table B.3.

to IB I/O controllers ~~providing~~ SRP target ports. The SRP target port identifier for

**Bro012 page 72 line 1****Closed**

'An IB I/O controller acting as an SRP target ports' could be construed as a 1-to-1 correspondence between controllers and target ports Suggested Solution: 'And IB I/O controller making SRP target ports available' or 'An IB I/O controller hosting SRP target ports'?

While the comment is correct, the 28 Nov 2001 teleconference agreed that it was better to **delete the entire paragraph** (page 72 lines 1-3).

**Bro013 page 72 lines 4-5****Closed**

*edit027, edit028 make this OK as modified:*

*IB I/O controllers providing SRP target ports shall include at least one ServiceName/ServiceID pair in the device management ServiceEntries attribute pair (see IBAS) as described in table B.8.*

'IB I/O controllers acting as SRP target ports' could be construed as a 1-to- 1 correspondence between controllers and target ports Suggested Solution: 'IB I/O controllers making SRP target ports available' or 'IB I/O controllers hosting SRP target ports'?

Proposed text:

~~IB I/O controllers acting as SRP target ports shall include at least one ServiceName/ServiceID pair in the device management ServiceEntries attribute pair defined in InfinibandTM Architecture Specification Volume 1 Release 1.0.a as described in table B.8.~~

An IB I/O controller's ServiceEntries attribute contains one or more ServiceName/ServiceID pairs. ServiceName/ServiceID pairs that meet the requirements listed in table B.8 shall identify an SRP target port.

edit027

'providing'

**Compaq comments:****CPQ001a [page i](#)****Closed**

Remove: American National Standard for Information Systems.  
See spc2r18 or spi4r07 (or other pre-public review versions) for style examples.

**CPQ001b [page i](#)****Rejected 28 Nov 2001**

Change "working draft SCSI RDMA Protocol" to "SCSI RDMA Protocol".  
The document is a working draft until it is published by ANSI or NCITS. NCITS requires that we prominently label it a "working draft" until then.

**CPQ002****Rejected 28 Nov 2001**

Update the PDF properties title and author  
These do not form part of the printed standard. Maintaining the properties is additional manual effort with no benefit.

**CPQ003 [page iii line 1](#)****Rejected 28 Nov 2001**

Remove revision history, line numbers, change bars, etc. from final version  
This is not a final version. See IBM002, IBM003.

IBM002

IBM003

**CPQ004 [page 1 lines 21-24](#), [page 2 line 25](#), [page 3 lines 19-21](#)****Closed**

Delete CAM from figure 1 Delete these SCSI-2 standards from the example standards list:  
Serial Storage Architecture SCSI-2 Protocol SSA-S2P [ANSI X3.294:1996] Common Access Method: SCSI Common Access Method CAM [ISO/IEC 9316-421] [ANSI X3.232:1996]  
The 28 Nov 2001 teleconference voted that this be accepted.

**CPQ005 [page 1 line 3](#)****Closed**

Change Fiber to Fibre

**CPQ006a [page 4 line 9](#)****Rejected 07 Jan 2002**

Add:

3.1.8 autosense data: Sense data (see 3.1.49) that is returned in the SRP\_RSP IU payload.  
See SAM-2.

CPQ033

"Autosense" is a mechanism for delivering sense data, the data delivered by autosense is just ordinary "sense data". SAM-2 does not define "autosense data". See CPQ033

**CPQ006b [page 5 line 4](#)****Closed**

*Used 'Proposed Text'.*

Add:

3.1.49 sense data: Data returned to an application client as a result of an autosense operation, asynchronous event report, or REQUEST SENSE command. See SPC-2.

Proposed text:

3.1.22a sense data: Data returned to an application client in the SENSE DATA field of an SRP\_RSP response or an SRP\_AER\_REQ request. See SAM-2.

**CPQ007 page 16 lines 28-31**

**Closed**

This section should mention the SRP\_CRED\_REQ and SRP\_CRED\_RSP IUs, which are dedicated to flow control service.

Replace the paragraph on lines 28-31 of [page 16](#) with the following:

SRP uses a credit based flow control algorithm to limit the number of SRP requests that an SRP initiator port may send to an SRP target port. The algorithm uses a field, REQUEST LIMIT DELTA, that is present in most information units sent by an SRP target port to an SRP initiator port, ~~and. The REQUEST LIMIT DELTA field is used to manipulate~~ a state variable, REQUEST LIMIT, ~~associated with each SRP initiator port. The value of the REQUEST LIMIT state variable determines whether or not the SRP initiator port may send new SRP requests.~~

Most information units containing a REQUEST LIMIT DELTA field do not generate a confirmation that the SRP initiator port has received the information unit and processed the contents of the REQUEST LIMIT DELTA field. The SRP\_CRED\_REQ request does generate a confirmation through the SRP\_CRED\_RSP response (see 6.10 and 6.11).

An SRP initiator port shall process the REQUEST LIMIT DELTA fields of information units received on the same RDMA channel in the order that they are received. An SRP initiator port shall process the REQUEST LIMIT DELTA field of a request before sending that request's response. E.g. an SRP initiator port shall process the REQUEST LIMIT DELTA field of an SRP\_CRED\_REQ request before sending the SRP\_CRED\_RSP (see 6.10 and 6.11).

The following rules specify the flow control algorithm for SRP requests sent by SRP initiator ports:

The second paragraph above directly addresses this comment. The third paragraph was added as a result of discussion during the 07 Jan 2002 teleconference.

**CPQ008 page 19**

**Closed**

intel0065 Table 2 Remove period from "NO DATA BUFFER DESCRIPTOR PRESENT."

**CPQ009 page 19 line 32**

**Closed**

intel0066 Table 2 There is no reference to note b. It probably needs to be in the 2h row buffer descriptor length cell, where "count" is used

Note that a reference is not always necessary, however in this case one is useful.

**CPQ010 page 19 line 36**

**Closed**

Table 2 Add a period at the end of note c.

**CPQ011 page 20 line 43 to page 21 line 3**

**Rejected 07 Jan 2002**

Add a fairly content-free table showing a direct data buffer containing a memory descriptor so this section has a visual reference like the indirect section.

Replace the text of this sub-clause (page 20 line 43 to page 21 line 3) with the following:

The DIRECT DATA BUFFER DESCRIPTOR format code value specifies that the corresponding data buffer descriptor field is sixteen bytes in length and contains a direct data buffer descriptor. The contents of the count field are reserved. SRP target ports are not required to check the contents of the count field. [Table 3a shows the format of a direct data buffer descriptor.](#)

**Table 3a - Direct data buffer descriptor**

Bit Byte	7	6	5	4	3	2	1	0
0	MEMORY DESCRIPTOR (see table 1)							
...								
15								

[The MEMORY DESCRIPTOR field of](#) a direct data buffer descriptor contains a single memory descriptor (see table 1). The memory descriptor identifies the data buffer, which is a single memory segment within a memory region's virtual address space. If a direct data buffer descriptor defines a data-out buffer, the SRP target port shall only issue RDMA Read operations using the memory descriptor contained in the direct data buffer descriptor. If a direct data buffer descriptor defines a data-in buffer, the SRP target port shall only issue RDMA Write operations using the memory descriptor contained in the direct data buffer descriptor. The SRP target port shall use the contents of the DATA LENGTH field of the memory descriptor as the length of the data-out buffer or data-in buffer.

**CPQ012 page 21 line 30**

**Closed**

IBM091

Table 4: note a count should be defined with a note b similar to that in table 2

The comment is intended to refer to table 4, not table 5. The 07 Jan 2002 teleconference directed that this comment be accepted.

**CPQ013 page 21 line 26**

**Rejected 07 Jan 2002**

Table 4 If n is zero in 16\*n+19, then the table shows byte 20 followed by byte 19. Remove the 20 and that numbering problem is eluded.

This is the common way of depicting variable length optional fields in many SCSI standards, including SPC-n, FCP-n and elsewhere in SRP.

**CPQ014 page 28 line 41****Closed**

Change: "maximum length" to "maximum length in bytes"

**CPQ015 page 28 lines 13-16****Rejected**

I thought we decided that TAG fields don't have bits labeled (MSB)/(LSB).

*EAG: Rejected : SAM-2 requires an arithmetic comparison of tag values (5.8.2 Overlapped Commands, pdf page 96 in sam2r21). Implementing an arithmetic comparison requires identifying the least and most significant bits. I believe that is the only requirement for this in all of SCSI, I would welcome its removal.*

*CRS: (Move from Rejected to Discussion) I find no such requirement for 'arithmetic comparison' to detect duplicates. A bit-by-bit compare will do fine. However, SAM-2 5.8.2 requires arithmetic evaluation for **reporting** overlapped tags:*

*If the overlapped command condition was caused by an untagged task or a tagged task with a **tag value exceeding FFh**, then the sense key shall be set to ABORTED COMMAND and the additional sense code shall be set to OVERLAPPED COMMANDS ATTEMPTED. Otherwise, an additional sense code of TAGGED OVERLAPPED TASKS shall be returned with the ADDITIONAL SENSE CODE QUALIFIER field set to the value of the duplicate tag.*

*I'd like to suggest a change in SAM-2 from "if tag value > FFh" to "if tag field size > one byte". With SRP's eight-byte tags, there doesn't appear to be any value to having one reporting scheme for tags 0-ffh, and another for 0100h-ffffffffffffh.*

*Latter tag reporting method obsoleted. Specifying MSB/LSB may have value for analyzers interpreting tags.*

**CPQ016 page 28 line 24****Closed**

Table 9 The REQUIRED BUFFER FORMATS cell is missing the horizontal lines present in other multibyte cells

**CPQ017 page 29 line 10****Closed**

Table 10 Remove period from first Reserved. row

**CPQ018 page 30 line 40 and page 30 line 44****Closed**

Change (two places): maximum length to "maximum length in bytes"

**CPQ019 page 33 line 46****Closed**

Table 14 Capitalize Reserved

**CPQ020 page 32 line 24****Closed**

Table 13 The SUPPORTED BUFFER FORMATS cell is missing the horizontal lines present in other multibyte cells

**CPQ021 page 36 lines 24-42****Rejected 07 Jan 2002**

Table 17 Add period after Reserved or remove from other rows

The rule is that a period should appear after descriptions that are sentences or major fragments of sentences, but not after simple words (e.g. no period after "Reserved").

**CPQ022 page 37 and page 38****Closed**

CRS: Also changed table 19 to TASK MANAGEMENT FUNCTION CODES

Rename TASK MANAGEMENT FLAGS to TASK MANAGEMENT FUNCTION. It doesn't really contain flags.

Rob Elliott will request the same change in other standards as they come up for review.

**CPQ023 page 38 lines 8-17****Rejected 07 Jan 2002**

Table 19 end each row with a period (or don't)

Each row that is a sentence ends with a period, which is correct. The row that is the isolated word "Reserved" does not end with a period, which is also correct. The period will be removed following "Restricted" in line 14.

**CPQ024 page 38****Closed**

Table 19 Change Codes to Code.

**CPQ025 page 38 line 5****Closed**

Table 19 Remove small caps from TABLE.

**CPQ026 page 39 lines 38-44****Rejected 07 Jan 2002**

Table 20 Per Patrick Fitzgerald at JNI, please require that DATA-OUT BUFFER DESCRIPTOR and DATA-IN BUFFER DESCRIPTOR start on 8-byte aligned boundaries. The ADDITIONAL CDB field is only 4 byte aligned.

This was discussed in several SRP working groups. It was raised as one of the potential issues with adding a total length field to indirect data buffer descriptors, since that field causes those descriptors to be a multiple of 4 bytes but not 8 bytes. Therefore it is impossible to align both descriptors in commands that contain both. We also discussed (in less length) the impact of wierd CDB sizes on buffer descriptor alignment. The unanimous concensus in all of these discussions was that there was no need to require 8 byte alignment of any buffer descriptor, 4 byte alignment was sufficient. Note that the first descriptor will in fact be 8 byte aligned for all common CDB lengths.

**CPQ027** [page 39 line 45](#) and [page 39 line 48](#) **Closed**

Table 20 footnotes Change: length to: length in bytes

**CPQ028** [page 40 lines 20-36](#) **Closed**

See SAM2r23.

Table 21 SAM-2 rev 20 still requires that untagged tasks be supported by all protocols. 01-318 will remove this requirement and make SRP legal.

Note that SPI-n also does not define a task attribute for untagged tasks when using information units, and now requires use of information units.

**CPQ029** [page 40 line 33](#) **Closed**

Table 21 Change a to an in the ACA row

**CPQ030** [page 40 line 20](#) **Closed**

Table 21 Remove small caps from TABLE

**CPQ031** [page 44 line 7](#) **Rejected 07 Jan 2002**

After: The STATUS field contains the status of a task that completes. See the SAM-2 standard for a list of status codes. Add this sentence and a table: Some of the status codes defined in SAM-2 are listed in table xx. Table xx - Some STATUS codes 00h GOOD 02h CHECK CONDITION 08h BUSY 18h RESERVATION CONFLICT 28h TASK SET FULL 30h ACA ACTIVE 40h TASK ABORTED This helps save the reader a reference to SAM-2 for the most popular fields.

The notion that anyone can understand or implement any SCSI protocol without referring to SAM-2 is fallacious. Encouraging anyone to avoid referring to SAM-2 will contribute to interoperability problems. Adding such a table will lead readers to infer that that table lists the only status codes they need to deal with. Redundantly defining status codes in multiple documents is a bad idea.

**CPQ032** [page 45 line 32](#) **Rejected 07 Jan 2002**

Remove from 2nd sentence of SENSE DATA paragraph: as specified by the SCSI Primary Commands-2 standard.

While the referenced text is redundant, a redundant reference is harmless. That sentence is copied verbatim from spi4r08.

**CPQ033** [page 45 lines 30-34](#) **Rejected 07 Jan 2002**

Reword the SENSE DATA paragraph to focus on the term autosense which is defined in SAM-2 rather than the REQUEST SENSE command in SPC-2. Change: The SENSE DATA field contains the information specified by the SCSI Primary Commands-2 standard for presentation by the REQUEST SENSE command. The proper sense data shall be presented when a SCSI status byte of CHECK CONDITION is presented by the SCSI Primary Commands -2 standard. to: The SENSE DATA field contains the autosense data (see SCSI Architecture Model - 2) when a SCSI STATUS byte of CHECK CONDITION is presented.



The present text is essentially identical to what every other autosense protocol specifies. While it might be desirable to formally define autosense data in SAM-2, then reference that from the protocol documents, that would need to start with the SAM-2 changes, not here. See CPQ006a.

**CPQ034 page 48 line 3****Rejected 07 Jan 2002**

Change report an asynchronous event. to: report an asynchronous event (see SAM-2).

Rather than add a cross-reference here, add a glossary entry for "aynchronous event" that will cross-reference SAM-2.

**CPQ035 page 48 line 3****Closed**

Add sentence to first paragraph: Parameters managing the use of asynchronous event reporting are contained in the Control mode page (see SPC-2). This sentence is in SAM-2, but a direct reference from SRP seems helpful.

**CPQ036 page 49 lines 3-8****Rejected 07 Jan 2002**

Reword the SENSE DATA paragraph like in 6.9, but don't call it autosense here, call it "sense data for the event".

See CPQ033

**CPQ037 page 52 line 15 and page 53 line 23****Rejected 07 Jan 2002**

Table 29 Section 7.3 LUN should be LU (this is broken in SPC too) - the logical unit number is irrelevant here.

SRP references SPC-2 and SPC-3, it uses the names used in those documents.

**CPQ038 Annex B****Closed**

Change (many places): Infiniband to: InfiniBand

The variable defining the reference to "InfiniBand™ Architecture Specification Volume 1 Release 1.0.a" will be corrected.

**CPQ039****Closed**

There are too many TMs. There only needs to be one per page or one per the whole section.

There is no way to accomplish one per page without unreasonable manual effort. While there may be more TMs than necessary, including them is at worst harmless, at best legally necessary. Many other documents include a TM with every reference. I will not change this without either a legal opinion or direction from the ANSI editor.

*7 Jan 2002 teleconference: Ed Gardner will obtain contact information for the ANSI editor (Harvey) from Ralph Weber, then confirm the proper style. This is the first T10 document that contains frequent references to a trademarked term.*

*26 April 2002: Cris sent email to Harvey. Harvey says we may add one(or more) TM notice, then use w/o in the spec.*

**CPQ040 Annex C**

**Closed**

Ralph Weber agreed to put alias formats for each protocol in SPC-3, so this annex can be removed.



**HP comments:**

*CRS: Added numbers to all HP comments for easier cross-referencing.*

**HP01 page 56****Closed**

*Feb1: Add table in Annex A for port name, identifier, etc. SAM mappings. Expectation was for persistence already, text will make explicit.*

Need a mandatory requirement to persistently report service names (DevMgtGetResp(ServiceEntries)) across IOU/IOC power cycles in order to persistently identify an SRP target port.

Description: Table B.8 describes the format of service name as SRP.T10:xxxxxxxxxxxxxxxx. Since the string xxxxxxxxxxxxxxxx in the service name identifies the 64 bit extension identifier value used to construct the SRP target port identifier, it is required that the service name reported by an IOU for a given SRP target port to be persistent across IOU/IOC power cycles. IB boot records contain SRP initiator port identifier, SRP target port identifier and logical unit name to locate an SRP boot LUN and the assumption is that the target port ID is persistent.

State that SRP port identifiers have the properties of names (see SAM-2: persistence, world-wide unique in context of SRP). Then the above falls out. \*\*\*\*\*

**HP02****Rejected Not reviewed**

These informal comments are the result of a newcomer's first in-depth reading of the SRP specification. I hope they will suggest avenues for further improvement, but they are not formulated at this time as specific requests for changes.

These comments derive from my work on iSCSI, and are in anticipation of development of iWARP, which will be an RDMA protocol for IP networks. IWARP is intended to provide a standard protocol-independent means of doing direct data placement into host memory, without the need for anonymous reassembly buffers. We anticipate that iSCSI and other Internet storage protocols such as CIFS and NFS will be adapted to iWARP. Inclusion of a formalized RDMA transport layer in the IP storage protocol stack places iSCSI on a path to converge with SRP.

Each protocol can learn from the other. Today, SRP, while meant to be generally applicable, is demonstrably applicable only to InfiniBand. iSCSI's applicability is similarly limited to IP networks. In the future, we may be able to engineer a single SCSI transport that works both with InfiniBand's RDMA service and with iWARP.

These are my personal comments, and are not meant to reflect an HP consensus. We at HP have not yet taken the time to form an internal consensus on SRP.

**HP03 page 1****Closed**

*CAP voted to reinstate 'transport', so have done so here. Also removed 'Physical;' from 'interconnect'*

Will clarify that this is a "SCSI protocol standard", as we are not able to call it a transport protocol.

It is not clear at the outset just what kind of standard SRP is. The text says that "the SCSI family of standards provides for many different transport protocols?" Is SRP a transport protocol? The text continues, "This standard defines the rules for exchanging information between SCSI

devices using an RDMA communication service." So SRP is a mapping from SCSI to an abstract RDMA communication service? What then is the SCSI transport? Is it the combination of SRP and the underlying real RDMA communication service? The standard continues, "Other SCSI transport protocol standards?" So, perhaps SRP is a SCSI transport. A statement along these lines would help a lot: "SRP, in combination with a compatible underlying RDMA communication service, is a SCSI transport. This document defines SRP and the requirements that SRP has for the underlying RDMA communication service."

**HP04 page 1****Closed**

*Figure 1 shows the relationship of SCSI protocol standards, such as this one, to the other standards.*

"Figure 1 shows the relationship of this standard to the other standards?" But it doesn't. The SRP standard is not identified in the figure. Despite the disclaimer, layering of the blocks does suggest a hierarchy, protocol stack and system architecture. But the figure does not indicate the applicability of SRP to the implementation of a SCSI transport, as far as I can tell.

**HP05 Page 2 Line 28****Rejected/Defer**

*WG directed that significant changes in the architectural model be deferred until SRP-2.*

SRP is included in a list of transport protocols. So it is a transport protocol. But certainly it is not a complete transport protocol. A discussion of how SRP is used in combination with an underlying RDMA service and its transport protocol to form a SCSI transport protocol would be very instructive to the reader. This would involve a layering diagram-why not?

**HP06 page 8****Closed**

*Abstract - yes,  
requirements - not formally.*

HP05

It would be useful to say at the beginning of clause 4 that the purpose of clause 4 is to describe an abstract RDMA service that is suitable for supporting SRP. That is, to define SRP's requirements of an underlying RDMA service.

**HP07 page 8****Closed**

*Removed last sentence in para above ("Components..").*

*Removed three sentences: "This clause...", "A specific...", and "Any of these...". Moved last sentence: "Annex B..." to end of first para of 4.1.*

"This clause describes various functions that may be provided?" Don't you mean to say that this clause describes various functions that must be provided by an RDMA service, in support of SRP? How the function is provided is immaterial, and of course it can be provided through further functional decomposition. Why mention it? Generally, this whole clause 4 seems to be descriptive of RDMA services in general, but not prescriptive in terms of SRP's requirements. It is difficult to separate descriptive information from requirements.

**HP08 Page 8 Line 20****Rejected**

*We don't talk about future versions of a standard.*

"Annex B describes the mapping of these functions?" Is it the intention of SRP to work with other RDMA services besides InfiniBand? If so, it might be useful to mention that future revisions of the standard may include other Annexes that define the mapping of SRP to other RDMA services.

**HP09 Page 10 Line 12****Rejected**

*CRS: Propose that this comment be rejected. WG agreed Feb 15.*

SRP is deficient in not providing a security protocol for client (initiator) authentication. Is the notion of "other parameters required by the RDMA communication service" to be interpreted as suggesting that the RDMA service itself should provide authentication? Given that SCSI port names are conveyed by SRP, this doesn't seem possible. (The RDMA service will have its own names for its end nodes, but they're not related to SCSI/SRP port names.)

**HP10 page 11****Closed**

*First sentence will be removed.*

"An RDMA communication service may require?" This sounds to vague and inclusive. What does SRP require of the RDMA service? That's all that should be defined in clause 4. It seems like SRP either will depend on the RDMA service's providing flow control for messages, or it will provide its own flow control. If SRP provides its own flow control, and doesn't depend on flow control from the RDMA service, then there is no reason to discuss flow control except maybe to mention that it is not required.

**HP11 Page 12 Line 40****Rejected**

4.5 Ordering and Reliability. Very glad to see this here. Wish it were in SAM-2.

**HP12****Closed**

IBM047

"Server address" probably should be "server identifier".

**HP13 Page 15 Line 24****Rejected**

Establishing multiple connections between an I,T port pair is an interesting concept, but may not be very useful, ultimately. The paragraph states that all such RDMA channels are associated with the single I\_T nexus. While there is no ordering assumed between different RDMA channels (15-41), this channel independence cannot be maintained once the tasks are forwarded to the SCSI layer, where the RDMA channel allegiance of the task is forgotten, and only the I\_T information is retained. Effectively, the tasks will merge from multiple transmission channels into a single queue as they transition from SRP to SCSI, and the original partial order will be replaced by a total order. Correct operation will result, but performance will suffer. Perhaps the only practical use of this construct is for the asynchronous transmission of task management requests, as in the given example.

**HP14 Page 16 Line 28****Rejected** |

A request windowing scheme would be easier to describe than this request limit mechanism. Race conditions would not be an issue.

**HP15 Page 20 Line 4****Rejected** |

Indirect data buffer descriptor. I don't see a good use for this facility in an IO application such as SRP, and I question its inclusion here. The channel adapter local to the memory that is to be read or written (typically the channel adapter of the Initiator) can use a scatter/gather list (SGL) to define an arbitrary virtual memory segment for an I/O buffer, and assign it a unique memory handle. This segment can then be read or written, starting at any offset, and in any order, by the target's RDMA mechanism's simply generating a series of RDMA reads or writes, always referring to the same memory handle, but using different offsets and lengths for each operation. (For example, a series of RDMA writes to increasing offsets, eventually filling the memory segment.) The direct data buffer descriptor format is sufficient for this operation, because the SGL provides for scatter/gather to bufflets that start and end at arbitrary addresses in physical memory (not just page-aligned addresses), just as a traditional DMA controller does.

The only motivation I can find for the indirect model is to reduce the number of SGLs (or mapped memory regions) that the initiator's channel adapter must deal with. Unfortunately, the use of the indirect mechanism means that we must trust the target devices that share a memory region not to step on each other through misoperation or by deliberately generating invalid memory descriptors. While this is the truest form of remote DMA, because it leave the matter of address generation to the target device, it also leave the initiator exposed to target device misoperation, or worse.

I am not sufficiently familiar with IB HCA architecture to know whether such HCAs are limited to mapping only regions of contiguous pages, which would necessitate including the indirect data buffer descriptor method to support non-page-oriented IO.

**HP16 page 28****Rejected/Defer** |

*We should consider separation for SRP-2.*

Login request. The statement that the login request "shall only be sent during RDMA channel establishment" seems to me overly restrictive on the RDMA model. Furthermore, I'm not sure I discern in clause 4 that the RMDA service must transport SRP login information during its own connection establishment, although this requirement is made clear in clause 5, line 14-13. It would seem quite natural to establish an RDMA connection first, and then log in SRP using the RDMA connection. (As an example, iSCSI establishes a TCP connection, and then logs it into a new or existing iSCSI session.)

HP09

**HP17 Page 25 Line 1****Rejected** |

Login request. Need to resolve how security protocols are handled in the SRP world. The login request does not contain any provision for initiator port authentication to the target.

**HP18 Page 25 Line 32****Rejected**

*SAM-2 r21 has no limits on port identifier size.*

So port identifiers are 16 bytes. But SAM-2 rev. 17 allows 8 bytes only, and iSCSI allows 260 bytes or more (still in discussion). These differences need to be rationalized. It would be best if SCSI itself would adopt a naming convention for its ports, rather than delegating this crucial task to its many transports. If SCSI were to name its ports, then SRP would only have to convey the SCSI port identifier passed down the stack by SCSI, and not make provision for conveying an identifier defined by a lower-level transport.

**HP19 Page 25 Line 32****Rejected**

*Feb1: WG agrees but sees no need to change.*

The port identifier fields, at 16B, are too small to carry identifiers as used by iSCSI. This may prove problematical as we attempt to merge iSCSI and SRP for use with iWARP.

**HP20 Page 54 Line 1****Rejected**

*A consumer may have many associated QPs.*

SRP annex. Are Queue Pairs (QP) in one-to-one correspondence with IB consumers?

**HP21 Page 54 Line 23****Rejected**

*That an IO Unit has a single CA is an IB decision - not within SRP's scope to define.*

"An IB I/O unit?contains an IB channel adapter." Why restrict it to a single channel adapter? In Figure B.3 the analogous (but nameless) initiator unit-defined by the dashed lines-is shown with multiple channel adapters. An iSCSI device is conceived as having multiple channel adapters (known informally as channel groups and in the specification as portal groups). OTOH, since an IB I/O unit is not named (it has no GUID associated with it), is there any purpose to the architecture's defining it?

**HP22 Page 54 Line 28****Rejected**

Yes.

Figure B.2. Can I/O controllers be virtual objects?

**HP23 Page 54 Line 28****Rejected**

*There's no reason to prohibit multiple consumers, and the term consumer is deliberately vague within the IB spec - it's the thing (e.g., a process) that reads/writes a QP. Multiple connections are independent of multiple consumers.*

Figure B.2. What is the purpose of allowing multiple IB consumers per IB I/O controller? Is it so that multiple IB connections can be terminated within an IB I/O controller? (This relates to the question above about correspondence between QPs and IB consumers.)

**HP24 Page 54 Line 28****Rejected**

*SCSI target ports contain the task router (SAM-2 4.7.2). There are no SRP restrictions on LU sharing.*

Figure B.2. How are shared LUs modeled? Do SRP target ports contain the "task router" function described recently by Penokie? Can two IB I/O controllers have an underlying LU in common, or is this functionality restricted to two IB consumers within the same IB I/O controller?

**HP25 Page 55 Line 9****Closed**

*Agreed. Should be removed.*

Table B.1. IB port GUID is described as "Identifies an IB port within an IB channel adapter". This can be taken to mean that the naming scope for IB port is within a single channel adapter. I doubt that is the intention, since IB port GUIDs are globally unique. Similar comment for IB I/O controller GUID?with the further observation that IB I/O units themselves are not named, and so cannot form a naming scope. It seems to me that the first three lines of this table should read, "Identifies a \_\_\_\_\_", without qualification. It is incidental, isn't it, that an IB port is contained in an IB channel adapter (and an IB I/O controller is contained in an IB I/O unit)? The fact that the discovery process finds IB channel adapters, and then IB I/O controllers, and then IB consumers, utilizing the containment properties, seems irrelevant to describing the naming architecture, when globally unique names are used.

**HP26 page 66****Closed**

*CRS: Propose that we remove the dashed line. It does not define a SCSI object, and the possible terms 'platform', 'node', or 'thingy' have no definition in the IB architecture. Approved at May 2 WG meeting.*

Figure B.3. What is the object indicated by the dashed lines in the initiator model, analogous to the IB I/O unit in the target model?

**HP27 page 66, page 16****Closed**

*CRS: Considering that targets can't derive any information (other than uniqueness) from an Init ID, the current text "should be constructed...", "should an IB GUID available to the SRP initiator port...", sounds like implementation suggestions.*

*We implicitly define the size of the IID and TID in SRP\_LOGIN\_REQ, but it seems that we should do so explicitly - Annex A? We may want to say "this part is a GUID, this is an extension", and then in Annex B say what GUID it is.*

*Feb15: Add a SRP-general description to Clause 5. In Anx B, Shall be a GUID (EUI?), should be a CA GUID + extension.*

Figure B.3. and 56-1. Table B.2. The rules for constructing initiator ports seem entirely too lax. The text says, "Initiator port identifier should be constructed?" And then the Table indicates that GUID, for example, is the channel adapter GUID. Is there no meaning associated with the initiator port ID? Is the only design goal that the 16B port ID be globally unique? Will any GUID do at all? If so, let's be explicit about this, and **let's not make any suggestions about the origin (and possible meaning) of the port name.**

OD4

But it would be a better model, I think, for the "GUID" used in the initiator port ID to be associated not with the IB channel adapter, but instead with the (unnamed) SRP initiator device. It is the SRP initiator device that is associated with a naming domain such as an operating system



image. IB channel adapters will be shared among operating system images, and using them as a naming domain would require that the operating system images cooperate, or that the selection of port identifier extension be delegated to the virtual machine layer, both of which are undesirable.

While we're at it, let's decouple the naming of SRP ports entirely from IB. Although SCSI really should be the layer that names its ports, let's for the moment assume that SCSI continues to delegate port naming to its transport. But let's assume further that SRP accepts the responsibility to name its ports, and doesn't delegate it further to IB. SRP can then generate its own name for SRP initiator device, with an identifier extension to make a unique port name. Analogously, SRP can name the entities identified in the figure as SRP target devices. SRP could adopt a naming scheme that uses 16B "GUIDs" analogously to IB's, and it could draw from the same naming assignment authority that IB uses. But this is not the same as saying that IB defines SRP's port names, and in fact, the description of SRP port naming would be moved from the IB annex to the main SRP text.

This change would require that during the discovery process, the IB I/O unit return the full name of the SRP port from its Service Entries table, in step 3.

This approach to naming ports brings SRP much closer to iSCSI. What is unresolved is iSCSI's use of long text strings to name iSCSI devices vs. the use of more compact GUID numbers. The two mechanisms could be combined with the introduction of a name service that dereferences string IDs to GUIDs.

**IBM / Tivoli comments:****IBM001 page i to page iv****Rejected Not reviewed**

Page c - The page numbering in first part of the front matter is a,b,c, and d instead of roman numerals. This needs to be corrected.

As described by George Penokie, the T10 cover page and related front matter (e.g. revision history) will be torn off and discarded, leaving the remainder of the document as the ANSI standard. That is, page a through page d will be discarded, leaving page i as the first page of the ANSI standard. This is the required result. Any page numbering other than the current document would result in ambiguous page numbers (e.g. two page i's) or the first page of the resulting standard being something other than page i.

**IBM002 page iii****Rejected Not reviewed**

Page c - d - The Revision list needs to be removed before public review.

CPQ003 This draft is and was not intended for public review. See CPQ003.

**IBM003 page iii****Rejected Not reviewed**

All - All the line numbers need to be removed throughout the document.

CPQ003 This draft is and was not intended for public review. See CPQ003.

**IBM004 page iii****Rejected Not reviewed**

All - The printing date information at the bottom of every page needs to be removed.

This is a draft for T10 review, not the final standard.

**IBM005 page xii line 3****Closed**

Page vii - Forward - the BSR number x3.269-199x is not correct for this standard. It should be 'NCITS.xxx-200x' until the actual number is assigned.

Bro103 See Bro103.

**IBM006 page xiii line 7****Closed**

Page viii - LIne 7 - The statement ' The working draft SCSI RDMA Protocol (SRP) standard is divided into the following clauses:' should be 'The SCSI RDMA Protocol standard is divided into the following clauses:

Bro105 The document is a working draft until it is published by ANSI or NCITS. NCITS requires that we prominently label it a "working draft" until then. See Bro105.

**IBM007****Rejected Not reviewed**

All - The acronym SRP should be replaced with 'SCSI RDMA Protocol' in all cases in this document.

IBM010

George Penokie has stated that T10 standards may either use an acronym or spell out the name of a standard, provided they are consistent. This standard consistently uses the acronym. See IBM010.

**IBM008a page 1 line 47, page 1 line 2****Rejected Not reviewed**

Page 1-2 - The following standards should be removed from the list: FC-AL and FC-PH. Both are approved standards that have not been withdrawn.

**IBM008b page 2 line 4****Rejected Not reviewed**

Page 2 - The following standard should be removed from the list: FC-PH-2. That standard is not present in the list.

**IBM008c page 2 line 10, page 2 line 20, page 2 line 31****Rejected Not reviewed**

Page 2 - The following standards should be removed from the list: SPI-3, FCP and SPC. All three are approved standards that have not been withdrawn. The follow-on projects for each of these have not been published or approved by INCITS (as of January 11, 2002).

**IBM008d page 3 line 8****Closed**

Page 3 - The following standard should be removed from the list: RMC.

**IBM009 page 4 lines 4-6****Rejected Not reviewed**

Page 4 - section 3.1.1 - The last sentence implies that SRP\_LOGIN\_RSP is the only use for accept data. I believe this is not correct. This should be stated to be an example of accept data.

Transporting an SRP\_LOGIN\_RSP is SRP's only use for accept data.

*CRS: I don't read the def as being exclusive in any case.*

**IBM010****Rejected Not reviewed**

All - The full name of a standard should always be used instead of the acronym. This should be change throughout the document.

IBM007

Duplicate comment. See IBM007.

**IBM011 page 4 line 19****Closed**

*CRS: There's a distinction between SRP the protocol and SRP the spec. SRP will always be the protocol, but SRP-2 will be the spec. Will use 'this protocol' in some places.*

Page 4 - line 19 and others - when SRP is used and it is referring to this document then it should be changed to 'this standard'. Line 19 is one case where this appears to be true.

Change "SRP" to "this standard" in: [page xiii](#) line 14, [page xiii](#) line 15, [page 4](#) line 5, [page 4](#) line 19, [page 4](#) line 37, [page 5](#) line 2, [page 5](#) line 8, [page 5](#) line 11, [page 8](#) line 4, [page 10](#) line 11, [page 10](#) line 28, [page 10](#) line 35, [page 11](#) line 44, [page 11](#) line 2, [page 11](#) line 5, [page 13](#) line 41, [page 13](#) line 44, [page 11](#) line 44

Other changes:

[page xiii](#) line 7: "The SCSI RDMA Protocol (SRP) standard" to "This standard".

[page xiii](#) line 17: "features for SRP, including the SRP mode pages" to "features for this standard".

[page 4](#) line 27: "the SRP" to "this standard".

[page 13](#) line 42: "Use of SRP" to "Operation".

Self-references not changed:

All IU names, SRP request, SRP response, SRP information unit, SRP device, all occurrences of SRP initiator/target port

[page 14](#) line 3, [page 14](#) line 3, [page 16](#) line 28, [page 26](#) line 1, [page 26](#) line 4

#### IBM012 [page 4](#)

Closed

*Replaced with definition from SAM2r22.*

Page 4 - section 3.1.13 - The statement 'An externally addressable object...' should be 'An.addressable object...'. The term externally implies that the addressing is outside the standard.

#### IBM013 PDF [Page 16](#)

Rejected

*\_LOGIN\_REQ is the only use, but don't believe that the statement as written is exclusive.*

Page 4 - section 3.1.15 - The last sentence implies that SRP\_LOGIN\_REQ is the only use for login data. If this is not correct. Then this should be stated to be an example of login data.

#### IBM014 PDF [Page 16](#)

Closed

Page 4 - section 3.1.15 - The statement '...server agent or consumer...' should be '....server agent or server consumer...'

#### IBM015 PDF [Page 16](#)

Closed

[edit014](#)

*Collecting all definitions in one comment.*

Page 4 - section 3.1 - The terms client consumer, server agent, and server consumer should be definitions in the glossary.

#### IBM016 PDF [Page 17](#)

Closed

Page 5 - section 3.1.22 - The statement '...server agent or consumer...' should be '....server agent or server consumer...'

**IBM017 PDF Page 17****Closed** |

See [IBM011 page 4 line 19](#)

Page 5 - section 3.2 - line 34 - The acronym for SRP implies that in almost all cases SRP should be changed to 'this standard'.

**IBM018 page 8****Closed** |

Page 8 - line 5 - The statement 'by means of' should be change to 'using'.

**IBM019 page 8****Closed** |

*'established and destroyed'*

Page 8 - line 44 - The statement 'established and disconnected' should be either 'established and removed' or 'connected and disconnected'. In this case I think the first option is better. The wording in the remaining document must then be make to match this change.

**IBM020 page 8****Closed** |

*Broke into subclauses. .*

Pages 8 - 11 - section 4.2 - This clause should be broken in subclauses and there should be references added between the steps in the figure and the text descriptions of those steps. This will help the reader relate the figures flow to the text.

**IBM021 page 10****Closed** |

Page 9 - lines 7-9 - The for example text should be change to (e.g., ....).

**intel0016 IBM022 page 9****Closed** |

*I think the intent was 'server box', but it is the AGENT that will recv the request. Added AGENT.*

Page 9 - line 2 - The statement '...directed to a server and, if...' is not clear because there is a server agent and a server consumer. Which is this server supposed to be?

**IBM023 page 9****Closed** |

*Removed those words. Server identifier is then explained in next sentences.*

Page 9 - line5 - The statement '...identify the server with which...' is not clear because t there is a server agent and a server consumer. Which is this server supposed to be?

**IBM024 page 9****Closed** |

*Pointed it upward at "wait for request".*

Page 9 - Figure 3 - line 40 - The arrow exiting to the right seems to dead end. Where does the flow go from there. All the other exit points are clear that one is not.

**IBM025 page 10****Closed**

'Server' is defined in SAM-2 as a SCSI object. Changed to: "the server identifier is an interconnect-specific value that enables the RDMA communication service to locate ~~shall identify~~ one or more SRP target ports,"

say "server identifier" identifies a server containing one or more target ports.

(t) Page 10 - line 12 - This states '...the server identifier shall identify one or more SRP target ports, and the login data...'. How is it possible for a single server identifier to identify more than one SRP port.? SCSI requires all target port identifiers be unique within a domain.

**IBM026 page 10****Closed**

*Removed entire sentence: "The actions required...", as this is an abstract description, and such statements are a given.*

Page 10 - at least lines 2-15 - The term 'server' is used by itself several times. There needs to be a qualifier on server so the reader does not assume that server equates to server agent and server consumer.

**IBM027 page 10****Closed**

*Removed some text to simplify, describe generic case, SRP case.*

Page 10 - lines 28 - 29 - The statement 'With SRP the reject data includes an SRP\_LOGIN\_REJ response (see 6.4).' Is confusing in that it implies the SRP (which is this standard) has additional requirements than what was just specific in the sentence before. That does not compute and needs to be fixed.

**IBM028 page 10****Closed**

*Agreed - removed..*

Page 10 - lines 31 -32 - Is it possible for an RDMA channel to be successfully established and not operational? If not then the statement 'and is operational' should be deleted. If so then it needs to be explained how it is possible.

**IBM029 page 10****Closed**

Page10 - line 34 - The statement '...server agent or consumer...' should be '....server agent or server consumer...'. This needs to be looked for throughout the document and corrected.

**IBM030 page 10****Closed**

*Removed some generic info to be less confusing.*

Page 10 - line 35 - The statement 'With SRP the accept data includes an SRP\_LOGIN\_RSP response (see 6.3).' Is confusing in that it implies the SRP (which is this standard) has additional requirements than what was just specific in the sentence before. That does not compute and needs to be fixed.

**IBM031** [page 11](#)**Closed** |

Page 10 - lines 44-45 - The statement 'With SRP the login data includes an SRP\_LOGIN\_REQ request (see 6.2)...' Is confusing in that it implies the SRP (which is this standard) has additional requirements than what was just specific in the sentence before. That does not compute and needs to be fixed.

**IBM032** [page 10](#)**Closed** |

Page 10 - lines 43 - 44 - The sentence 'The server agent is provided the login data from the client consumer's request in addition to RDMA communication service specific data.' is awkward. It would be better stated as 'The server agent receives the login data and RDMA communication service specific data from the client consumer's request.'

**IBM033** [page 11](#)**Closed** |

Page 11 - line 2 - The statement 'With SRP the reject data shall contain an SRP\_LOGIN\_REJ response (see 6.4).' Is confusing in that it implies the SRP (which is this standard) has additional requirements than what was just specific in the sentence before. That does not compute and needs to be fixed.

**IBM034** [page 11](#)**Closed** |

Page 11 - lines 5 - 6 - The statement 'With SRP the accept data shall contain an SRP\_LOGIN\_RSP response (see 6.3)...' Is confusing in that it implies the SRP.(which is this standard) has additional requirements than what was just specific in the sentence before. That does not compute and needs to be fixed.

**IBM035** [page 11](#)**Closed** |

Page 11 - line 11 - The term 'such' should be deleted.

**IBM036** [page 12](#)**Closed** |

Page 11 - lines 30-31 - The statement '...to deliver the message to the other consumer associated with the specified RDMA channel (the receiving consumer).' should be changed to '...to deliver the message to the receiving consumer.' There is no need to redefine what a receiving consumer is as that is done in the first paragraph of this section.

**IBM037** [page 12](#)**Closed** |

Pages 11 - 12 - section 4.4 - This clause should be broken in subclauses. For example at least an overview, one for read RDMA, and one for write RDMA. PDF Page 24

**IBM038** [page 12](#)**Closed** |

Page 12 - line 5 - The statement 'as well' should be deleted.

**IBM039** [page 12](#)**Closed** |

Page 12 - line 14 - The following statement 'Such information may be communicated by an application protocol.' Does not seem relevant to this standard and should be deleted.

**IBM040** [page 13](#)**Rejected** |

*CRS: No - I read it to say 'We expect an RDMA CS supporting SRP to behave this way. If it doesn't, not our problem.'*

Page 12 - lines 41-43 - This paragraph contains information that is not useful and should be deleted. It essentially states that RDMA communication has characteristics defined here and those not defined here are out side the scope of this standard. That is true but it is also true for every clause in this standard.

**IBM041** [page 13](#)**Closed** |

Page 12 - line 45 - The statement 'or else' should be just 'or'.

**IBM042** [page 13](#)**Closed** |

*Feb15: As suggested by Bob Nixon: "without duplication"*

Page 12 - line 46 - The term 'exactly' should be deleted. There is no difference between 'exactly once' and 'once'.

**IBM043** [page 12](#)**Rejected** |

*Disagree - they are names of the operations.*

Page many - The terms Write and Read in RDMA Write and RDMA Read should not be capitalized.

**IBM044** [page 13](#)**Closed** |

Page 13 - line 14 - The term 'satisfy' should be changed to 'meet'.

**IBM045** [page 14](#)**Closed** |

*Added (see SAM-2). Added comma after i.e. .*

Page 14 - line 8 - The statement 'I\_T nexus' is correct but there is no reference to where one would find out more about what it is. This needs to be added.

**IBM046** [page 14](#)**Closed** |

*Dropped 'for its lifetime'*

Page 14 - line 7 - The statement 'for its lifetime' is not clear. It should be stated as 'as long as it is established'. This ties it to the previous section. Note this assumes that the term established in 4.2 is not changed.



**IBM047 page 14****Closed***Removed para.*

Page 14 - lines 24-28 - This whole paragraph does not look like it belongs here or anywhere and it should be deleted. It appears to be attempting to defines things that are either already defined in section 4 or don't need to be defined.

**IBM048 page 15****Closed**

*While this does seem redundant, removing it would leave "tasks sent on that RDMA channel", which doesn't quite seem right, as we send IUs, not tasks.*

*At Feb15 mtg. decided to stay with original suggestion.*

Page 14 - line 40 - The statement 'that were contained in SRP\_CMD requests (see 6.8)' should be deleted as it is redundant with the statement 'outstanding SCSI tasks'.

**IBM049 page 13, page 15****Closed***Accept.*

*We need to expand clause 4 discussion of Send (and other operations) to discuss completion, e.g., how long target waits after the Send before doing the disconnect. - DONE.*

*New text: An SRP target port should send an SRP\_T\_LOGOUT request (see 6.6) and wait for the RDMA communication service status indication (see 4.5.2) before requesting that an RDMA channel be disconnected. George wants SHALL send, unless TP does not have a credit (as in case of IP not responding to a SRP\_CRED\_REQ).*

intel0042

(t) Page 14 - line 43 - The statement '...an SRP target port should send an...' gives inadequate guidance to a target implementor. This should be required to send the SRP\_T\_LOGOUT or not send it. Or it should be specified when it is required to be sent and when it is not required to be sent.

**IBM050 PDF page 16****Closed**

*Accepted - Requested wording from George that isn't too broad here.*

edit040

*Need to include clearing effects table, maybe? SEE EDIT040 for I\_T Nexus Loss.*

(t) Page 15 - line 4 - I recommend adding into this list a statement that other SCSI related parameters (e.g., mode pages, logs) not be effected by the disconnect. This should avoid the hole the FC has dug for itself in this area.

**IBM051 page 14****Closed**

Page 15 - line 18 - The statement '...operation, if accepted, may allow...' should be '...operation may allow...'. The if accepted is redundant with may.

**IBM052 page 15****Closed**

Page 15 - line 36 - The term 'may' should be deleted.

**IBM053** [page 15](#) **Closed** |

Page 15 - lines 36-40 - the format of the e.g is incorrect. It should be...'standards (e.g., ...)'.|

**IBM054** [page 16](#) **Closed** |

Page 15 - line 49 - The statement 'as well as' should be 'or'.|

**IBM055** [page 16](#) **Closed** |

*Going with 'start', although I think we'd do better to say that some event (sending/reception of request) communicates the start.*

Page 16 - line 3 - The term 'initiation' should be 'start' or 'beginning'.|

**IBM056** [PDF Page 28](#) **Closed** |

*Fixed when cleaning up IBM057.*

Page 16 - line 5 - The term 'all' should be 'the'.|

**IBM057** [PDF page 16](#) **Closed** |

*To A, add SRP\_CMD. Cover all SRP\_reqs.*

Page 16 - lines 7-8 - I am not aware of a SCSI command that specifies that status not be returned. If there is such a thing then an e.g., would be helpful. If there is no such thing then this item should be deleted. |

**IBM058** [PDF page 16](#) **Closed** |

Page 16 - line 18 - What is the 'it' referring to? The 'it' needs to be replaced with whatever 'it' is. |

**IBM059** [page 16](#) **Closed** |

Page 16 - line 23 - The term 'might' should be 'may'.|

**IBM060** [page 16](#) **Rejected** |

*Unable to see what could be confused. Willing to consider suggestions on text that wouldn't be extremely awkward.*

Page 16 - line 23 - What is the 'it' referring to? The 'it' needs to be replaced with whatever 'it' is. |

**IBM061** [page 16](#) **Closed** |

Page 16 - line 24 - The statement '...to at most one...' seems redundant. It should be '...to one...'.|

**IBM062** [page 17](#) **Closed** |

*Not in: LOGIN\_REJ, T\_LOGOUT,*

Page 16 - lines 28-29 - The statement '...present in most information units...' is troublesome. There either needs to be a list of the IUs that have the field or a reference to a place that would tell my which IUs have or do not have the field.

**IBM063 PDF Page 28****Closed**

*Have changed here to "Request Limit Delta", etc, and suffixed with 'variable' or 'field' where possible.*

Page 16 and others? - The when to use small caps rule is not being followed here. The rule is that small caps are only used when the field is being named (e.g., xxx field would have the xxx in small caps). When contents of the field is being called out it is not in small caps (e.g. request limit and request limit delta are both signed...').

**IBM064 page 17****Closed**

Page 16 - line 49 - The sentence starting with 'An SRP port shall not specify a negative...' should be a separate item in the list.

**IBM065 page 16****Closed**

*Feb1: Change flow control to "target port buffer management". No change to non-commands.*

(t) Page 16 - section 5.3 - This section on flow control seems overly complex for what appears to be actually needed. The only SRP request that even needs to have multiple outstanding requests in the command. All others should not be streamed but should be interlocked and some should be allowed to occur at any time. This all needs to be looked at to make sure the design point is what we really want.

**IBM066 page 18****Closed**

Page 17 - Figure 4 - The way the arrows are pointing for the virtual address implies that it is not the address of the first byte of the memory segment. It currently implies that it is the space from the memory handle to the beginning of the memory segment which is the memory region. It is also not clear as to what the boundaries are of the memory region. The current drawing implies it is only the area above the memory segment. I do not believe that is correct so it needs to be fixed.

**IBM067 page 18****Closed**

Page 17 - line 26 - There is no indication as to what kind of value the memory handle is. This would normally not be a problem except that the other two fields to explicitly indicate that they are unsigned integer values. I generally consider all fields to be unsigned integers but in this case there is doubt cast about that assumption.

**IBM068****Closed**

Page 18 - line 1 - The statement 'A SRP...' should be 'An SRP...' This needs to be checked for throughout the document and corrected.

**IBM069****Closed** |

Page 18 - line 3 - The statement '...within its memory segment.' should be '...within the memory segment.'

**IBM070****Rejected** |

*The previous sentence says it can do only a single operation, but this says it must do the correct operation.*

intel0060

Page 18 - line 2 - The statement 'SRP target ports shall only issue the appropriate type of RDMA operation for a memory descriptor' appears to be restating what was stated in the previous sentence and therefore should be deleted. The sentence would then read 'SRP target ports shall ensure that each RDMA operation...'

**IBM071 page 19****Closed** |

Page 18 - line 3 - There needs to be a connection between the text above the a.b.c list and the list. Something like 'segment by using the following rules:'.

**IBM072 PDF Page 30****Rejected** |

*It is redundant, but not harmful.*

Page 18 - lines 15-17 - The sentences

'The format of each data buffer descriptor is specified by a format code value. Some data buffer descriptor format code values use the contents of a count field to further specify the data buffer descriptor format.'

should be deleted as the information is a duplicate of what is in table 2.

**IBM073 PDF page 19****Closed** |

Page 18 - table 2 - line 35 - footnote c - There statement 'and and' should be just 'and' and there is not period at the end of the sentence.

**IBM074 PDF Page 30****Closed** |

Correct character is not x, but:  $\times$  &#215; Multiplication Sign (Frame ctrl+q 0)

Page 18 - table 2 - line 27 - The equation  $20+16*\text{count}$  should be change to  $20 + 16 \times \text{count}$ . This change from \* to  $\times$  should be make throughout the document.

**IBM075 PDF Page 30****Closed** |

CPQ009

Page 18 - table 2 - footnote b - This should have a reference from the cell with 'count' in it.

**IBM076 page 19****Closed** |

*Added "shall not issue an SRP\_CMD request (see 6.8) indicating a data buffer"*

Page 18 - lines 43-45 - The sentence 'An SRP initiator port shall not specify a data buffer descriptor format that was not indicated in the REQUIRED BUFFER FORMATS field value for that RDMA channel.' does not make sense. How can the initiator port be indicating the buffer

formats in the REQUIRED BUFFER FORMATS field and at the same time not specifying the buffer formats in the REQUIRED BUFFER FORMATS field that were not indicated in the in the REQUIRED BUFFER FORMATS field. This is circular and needs to be fixed.

**IBM077** [page 19](#) **Closed** |

Page 18 - line 41 - There should be a reference to table 2 as follows 'data buffer descriptor formats (see table 2)'.

**IBM078** [page 20](#) **Closed** |

*channel establishment request*

Page 18 - line 47 - The statement '...RDMA channel and...' should be '...RDMA channel request and...'.

**IBM079** [page 20](#) **Closed** |

*channel establishment request*

Page 18 - line 49 - The statement '...RDMA channel and...' should be '...RDMA channel request and...'.

**IBM080** [page 19](#) **Closed** |

Page 18 - line 40 - There should be a reference to table 3 as follows 'The REQUIRED BUFFER FORMATS field (see table 3)...'.

**IBM081** [page 20](#) **Closed** |

Page 19 - line 4 - I believe the 'and' should be an 'or'. I don't believe a target port would do both IU at the same time.

**IBM082** [page 20](#) **Closed** |

Page 19 - lines 3-4 - There should be a reference to table 3 as follows 'The SUPPORTED BUFFER FORMATS field (see table 3)...'.

**IBM083** [page 20](#) **Closed** |

Page 19 - line 8 - The statement '...contents of the REQUIRED BUFFER...' should be '...contents of both the REQUIRED BUFFER....'.

**IBM084** [page 20](#), [page 20](#) **Closed** |

*Two parts:*

*Init tells targ whether Init 'may use' IDBDs. Text implies that setting IBDB to zero in LOGIN\_REQ is a promise that init will not send a CMD w/ an IDBD, but does not so state.*

*In request, reword to say initiator sets to specify whether it uses indirect format. Do not use should or shall.*

edit010

*Added reference to what T\_LOGOUT codes to report if detected..*

(t) Page 19 - line 18 and line 28 - Why is that when the IDBD bit and the DDBD bit is set to zero it is a should instead of a shall? This should be changed to a shall unless there is some good reason.

**IBM085 page 20****Closed**

Page 19 - note 2 - This note should not be a note. It should be part of the main text. It should also be restated as: 'The length of requests sent by an SRP initiator port, as determined by the data buffer descriptor formats, shall be limited to the MAXIMUM INITIATOR TO TARGET IU LENGTH field (see xxx) returned in the SRP\_LOGIN\_RSP response.'

**IBM086 PDF page 20****Closed**

Accept.

(t) Page 19 - lines 39 - 40 - The sentence 'SRP target ports are not required to check the contents of the count field.' should be changed to 'SRP target ports shall ignore the contents of the count field.'

**IBM087 page 21 , page 36****Closed**

*EAG: Accept. Remove invalid count logout reason codes. Add incorrect IU length reason code.*

intel0096

*CRS: Corrected text. Handling reason code under intel0096.*

(t) Page 19 - lines 44 - 45 - The sentence 'SRP target ports are not required to check the contents of the count field.' should be changed to 'SRP target ports shall ignore the contents of the count field.'

**IBM088 page 20****Closed**

*Added SRP\_CMD, leaving as singular since we examine each in isolation.*

Page 19 and others - line 39 and others - The term 'count field' is used in many places. First there are two of them so it should be 'count fields'. Second is not clear that these are the count fields in the SRP\_CMD request. I recommend changing 'count field' to 'count fields in the SRP\_CMD request' in all places in the main body text.

**IBM089 PDF Page 32****Closed**

intel0064

Page 20 - line 8 - The statement 'count field' should be 'DATA-OUT BUFFER DESCRIPTOR COUNT field (or DATA-IN BUFFER DESCRIPTOR COUNT field)'.

**IBM090 page 21****Closed**

*GOP: Says ref should be to FIGURE 5, not table 5.*

Page 20 - line 12 - A reference to table 5 should be added to the end of the paragraph.

**IBM091****Closed**

CPQ012

Page 20 - table 4 - line 29 - Footnote a - It's not clear which count field is being referred to. Is it the one in table 2 or the ones in the SRP\_CMD\_ request. This needs be fixed with the proper terminology and a reference to the correct place.

**IBM092 page 21****Closed**

*Comment is wrong, but paragraph was very awkward. Reworded. George pointed out that a descriptor IS NOT a field.*

Page 20 - line 34 - The statement 'The DATA LENGTH field of the INDIRECT TABLE MEMORY DESCRIPTOR field value contains...' is not correct. It should be 'The DATA LENGTH field of the memory descriptors in the indirect table contains...'

**IBM093 page 22****Closed**

*said "IS vendor-specific"*

Page 20 - line 39 - The sentence 'SRP target port behavior when the TOTAL LENGTH field contains any other value is vendor specific.' should be moved to the end of the paragraph and restated as 'If the TOTAL LENGTH field value is not equal to the to sum of the DATA LENGTH field values the SRP target port's behavior shall be vendor specific.'

**IBM094 page 22****Closed**

intel0064

Page 20 - line 42 - It's not clear which count field is being referred to. Is it the one in table 2 or the ones in the SRP\_CMD\_ request. This needs be fixed with the proper terminology and a reference to the correct place.

**IBM095 page 22****Closed**

Page 20 - line 47 - This should be the start of a new subclause. Something like 'SRP target port indirect data restrictions'. PDF Page 33

**IBM096 page 22****Closed**

Page 21 - line 7 - This paragraph should be the start of a new subclause titled something like 'Examples of Indirect data buffers'.

**IBM097 page 19****Closed**

*Although intended and supported, we don't show any examples or discuss it. Add a picture, some text, including that DBDs are not trequired to be same type. May need new heading.*

*Added text, no picture, didn't seem worth 1000 words. April 5: GOP agrees.*

(t) Page 20 and 21 - The possibility of having both a data-in and a data-out buffer is not described here. Why not? This needs to be fixed.

**IBM098** [page 17](#), [page 23](#)**Closed**

*Made change in items f and g in list on [page 17](#).*

Page 21 - lines 12 and 13 - The term 'might' should be changed to 'may'. This should be done throughout this document.

**IBM099** [page 27](#)**Closed**

Page 23 - line 48 - The statement 'A requestor shall provide a TAG value in each SRP request that is unique among all of the requestor's outstanding SRP requests with a particular responder. A responder shall copy the TAG value from each SRP request to the SRP request's SRP response. Responders are not required to check whether the TAG values of outstanding SRP requests are unique.'

should be

'Each SRP request shall contain a TAG value that is unique among all of the outstanding SRP requests from a particular SRP initiator port. Each SRP response shall contain a copy of the TAG value from the corresponding SRP request. Responders are not required to check whether the TAG values are unique.'

**IBM0100****Rejected**

*'Communicate' is one of the meanings for 'convey', which is the sense here. An IU is SENT, anyway.*

Page 25 - line 2 - The term 'conveys' should be changed to 'sends'.

**IBM0101** [page 28](#)**Closed**

Page 25 - line 42 - The statement '...wishes to send...' should be changed to '...sends...'.

**IBM0102** [page 28](#)**Closed**

Page 25 - line 42 - The statement '....be 64 or larger.' should be '....be greater than or equal to 64.' or '...be greater than 63.'.

**IBM0103** PDF [Page 38](#)**Closed**

Page 26 - lines 1-2 - The statement 'The MULTI-CHANNEL ACTION field identifies how an SRP target port treats any existing RDMA channel associated with the same I\_T nexus. The MULTI-CHANNEL ACTION field is defined in table 10.' should be changed to 'The MULTI-CHANNEL ACTION field (see table 10) indicates how an SRP target port handles existing RDMA channels.associated with the same I\_T nexus.'.

**IBM0104** [page 29](#)**Closed**

*Field is two bits, not a byte. Changed to 00b notation.*

Page 26 - table 10 - All the codes except for the 2 that are defined need to be listed as reserved. The row should have '02h - FFh' in the action column and 'reserved' in the description column.



	<b>IBM0105 PDF Page 39</b>	<b>Rejected</b>
IBM0100	Page 27 - line 2 - The term 'conveys' should be changed to 'sends'.	
	<b>IBM0106 page 31</b>	<b>Closed</b>
	<i>'handled', not 'handles'. Reporting the results of a particular request, not general behavior.</i>	
	Page 28 - lines 1-2 - The statement 'MULTI-CHANNEL RESULT identifies how the SRP target port treated existing RDMA channels associated with the same I_T nexus. Table 12 defines this field.' should be changed to 'The MULTI-CHANNELRESULT field (see table 12) indicates how an SRP target port handles existing RDMA channels associated with the same I_T nexus.'	
	<b>IBM0107 page 31</b>	<b>Closed</b>
	<i>Field is two bits, not a byte. Changed to 00b notation.</i>	
	Page 28 - table 12 - All the codes except for the 3 that are defined need to be listed as reserved. The row should have '03h - FFh' in the action column and 'reserved' in the description column.	
	<b>IBM0108 PDF Page 42</b>	<b>Closed</b>
	Page 30 - line 4 - The statement '...failed, rendering it non-operational.' should be changed to '...failed.'	
	<b>IBM0109 PDF Page 43</b>	<b>Closed</b>
	Page 31 - line 4 - The statement '...failed, rendering it non-operational.' should be changed to '...failed.'	
IBM0100	Page 32 - line 2 - The term 'conveys' should be changed to 'sends'.	
	<b>IBM0110 PDF Page 44</b>	<b>Closed</b>
	<i>The LOGICAL UNIT NUMBER field identifies the logical unit to which the task management request is directed.</i>	
	Page 32 - lines 37-38 - The statement '...logical unit component of the nexus for the task management request.' should be changed to '...logical unit to which to send task management request.'	
	<b>IBM0111 PDF Page 46</b>	<b>Rejected</b>
IBM0100	Page 34 - line 2 - The term 'conveys' should be changed to 'sends'.	
	<b>IBM0112 page 40</b>	<b>Closed</b>
	<i>Splits a paragon!? Ouch! Started new paragon after first sentence.</i>	
	Page 34 - 35 - Table 20 - This table splits up a paragon and worse a sentence. This needs to be fixed.	

**IBM0113 PDF Page 46****Closed**

Added single quotes around 'do' and 'di'.

Page 34 - table 20 - The notation 'do' and 'di' are confusing when placed into a sentence (as in the footnotes). They should be changed to 'x' and 'y'.

**IBM0114 PDF Page 48****Rejected**

IBM0100 Page 36 - line 2 - The term 'conveys' should be changed to 'sends'.

**IBM0115 page 42****Closed**

Page 36 - line 6 - The statement '...message capable of containing...' should be changed to '...message containing...'.

**IBM0116 page 43, et al.****Closed**

Page 37 - The statement 'set to 1' should be 'set to one' and the statement 'set to 0' should be 'set to zero' in all cases throughout this document.

**IBM0117 page 44****Closed**

Page 37 - line 44 - The statement 'are not reliable and' should be deleted as it contains no useful information.

**IBM0118 page 44****Closed**

Page 38 - line 3 - Add a reference to the RSP\_CODE values table (table 24) at the end of this paragraph.

**IBM0119 page 44****Closed**

(t) Page 38 - lines 15-17 - The statement 'If DOUNDER is set to 1, a transfer that did not use the entire data-out buffer was performed and the value of DATA-OUT RESIDUAL COUNT shall be equal to: data-out buffer length - highest offset of any data-out byte transferred - 1' needs to be changed to 'If DOUNDER is set to one and a transfer that did not fill the entire data-out buffer was performed the value of DATA-OUT RESIDUAL COUNT is defined as follows: DATA-OUT RESIDUAL COUNT = (data-out buffer length) - (highest offset of any data-out byte transmitted + 1)'

**IBM0120 page 44****Closed**

(t) Page 38 - lines 22-23 - The statement 'DATA-OUT RESIDUAL COUNT shall be equal to: data-out transfer length required by command - data-out buffer length' needs to be changed to 'The DATA-OUT RESIDUAL COUNT is defined as follows: DATA-OUT RESIDUAL COUNT = (Transfer length required by command) - (data-out buffer length)'

**IBM0121 page 44****Closed**

(t) Page 38 - lines 34-36 - The statement 'If DIUNDER is set to 1, a transfer that did not fill the entire data-in buffer was performed and the value of DATA-IN RESIDUAL COUNT shall be equal to: data-in buffer length - highest offset of any data-in byte transferred - 1' needs to be changed to

' If DIUNDER is set to one and a transfer that did not fill the entire data-in buffer was performed the value of DATA-IN RESIDUAL COUNT is defined as follows:

DATA-IN RESIDUAL COUNT = (data-in buffer length) - (highest offset of any data-in byte transmitted + 1)

**IBM0122 page 45****Closed**

(t) Page 38 - lines 41-43 - The statement 'DATA-IN RESIDUAL COUNT shall be equal to: data-in transfer length required by command - data-in buffer length' needs to be changed to "The DATA-IN RESIDUAL COUNT is defined as follows: DATA-IN RESIDUAL COUNT = (Transfer length required by command) - (data-in buffer length)'.

**IBM0123 page 45****Closed**

Page 39 - line 1 -The term 'certain' should be deleted.

**IBM0124 page 45****Closed**

*May15: George confirms that RSPVALID is a typo, should be SNSVALID.*

(t) Page 39 - lines 30 - 41 - All this should be deleted and replaced with 'The SENSE DATA field contains the autosense data specified by the SCSI Primary Commands-2 standard. The proper SENSE DATA shall be presented when the SCSI status byte of CHECK CONDITION is presented as specified by the SCSI Primary Commands-2 standard. If no conditions requiring the presentation of SCSI sense data have occurred, the SENSE DATA field shall not be included in the SRP\_RSP response and the RSPVALID bit shall be zero. SRP devices shall perform autosense.'

**IBM0125 page 48****Closed**

*It's not transport stuff in view here.Changed to : "A target port sends an SRP\_AER\_REQ request (see table 27) to report an asynchronous event. "*

Page 41 - line 2 - The term 'conveys' should be changed to 'sends'.

**IBM0126 page 49****Closed**

*Added 'as': ' data as specified...'*

CPQ036

(t) Page 42 - lines 3-13 - All this should be deleted and replaced with the following "The SENSE DATA field contains sense data specified by the SCSI Primary Commands-2 standard.'. This is AER not a check condition they are different things. The only thing that should be stated here is that sense data is returned.

	<b>IBM0127</b>	<b>Closed</b>	
IBM0116	Page 44 and others - line 16 and others - The term 'set to 0' and 'set to 1' should be 'set to one' and 'set to zero'.		
	<b>IBM0128 page 53</b>	<b>Closed</b>	
	Page 44 - line 19 - The term 'all' should be deleted as it is redundant.		
	<b>IBM0129</b>	<b>Closed</b>	
intel0145	<i>Text was present, but had wrapped out of view.</i> Page 46 - figure A.2 and A.3 - line 15 and 43 - The statement '(SRP initiator' should be '(SRP initiator port)'		
	<b>IBM0130 page 55</b>	<b>Closed</b>	
	Page 46 and others- lines 22-26 and others - The 1,2,3 list should not have line spaces between numbered items. This should be fixed in all cases		
	<b>IBM0131 page 62</b>	<b>Closed</b>	
	<i>'executes' is from IBA glossary.</i> Page 52 - line 20 - The term 'executes' should be changed to 'processes'.		
	<b>IBM0132 page 62</b>	<b>Closed</b>	
	Page 52 - line 32 - The statement '...a device or component...' should be 'an IB device or component...'		
	<b>IBM0133 PDF Page 65</b>	<b>Closed</b>	
	<i>It's 'Communication Manager'. Corrected acronyms.</i> Page 53 - line 20 - There seems to be no definition of what a 'connection manager' is. This should, at least, be added to the glossary.		
	<b>IBM0134 PDF page 63</b>	<b>Closed</b>	
	Page 53 - section B.3.2 - The abbreviation IOC needs to be added to the list.		
	<b>IBM0135 PDF Page 67</b>	<b>Closed</b>	
Bro004	Page 55 - lines 1-2 - The sentence 'The IB more IB LIDs and IB GUIDs corresponding to an IB port GUID or IB channel adapter GUID.' does not seem to be a complete sentence and is not clear as to what it is trying to state. This needs to be fixed.		

**IBM0136 page 66** **Closed** |

*Accept.*

(t) Page 56 - line 2 - Why is the should not a shall. I believe it should be changed to a shall.

**IBM0137 page 67** **Closed** |

*State that shall use IB GUID, but don't mention CA GUID or other specific GUID source.*

Page 56 - line 15 - The statement '...field should an IB GUID...' should be '...field should be an IB GUID...'.

**IBM0138 page 67** **Closed** |

Page 56 - line15 - The statement '...port, e.g. the...SRP initiator port.' should be '...port (e.g., the...SRP initiator port).'.

Bro007

**IBM0139 PDF Page 68** **Closed** |

Page 56 - lines 15-16 - The statement 'the IB channel adapter GUID for an IB channel adapter used the SRP initiator port.' is not very clear as to what it is. This needs to be fixed.

**IBM0140 page 67** **Closed** |

*Added 'IB' to clarify that it is an IBA-defined thing.*

Page 56 - line 20 - There is not clue as what a 'device management agent' is. This could be fixed by replacing 'device management agent' with the more generic term 'entity'.

**IBM0141 page 67** **Closed** |

Page 56 - line 22 - The term 'indicated' is confusing in this sentence. A better term would be 'identified'.

**IBM0142 page 67** **Closed** |

Page 56 - line 39 - The term 'indicated' is confusing in this sentence. A better term would be 'identified'.

edit004

**IBM0143 PDF Page 68** **Closed** |

Page 56 - lines 41-42 - This sentence seems out of place here. I should be moved to right after figure B.3.

**IBM0144** **Closed** |

Page 56 - line 49 and page 57 - line 1 - The term ' IB I/O ' has been split across lines (and in this case across pages) at the /. This needs to be fixed so it will not happen. There is an option in frame that if selected will prevent this. It should be enabled for this document.

**IBM0145** [page 68](#)**Closed** |

Page 57 - line 34 - The 'it' at the beginning of the sentence should be replaced with whatever the 'it' is.

**IBM0146** [page 68](#)**Closed** |

intel0170

Page 57 - line 46 and page 58 - line 1 - Why is the receive data-out mapped to RDMA requests and send data-in mapped to RDMA WRITE packets? One is a 'request' the other a 'packet' this seems strange shouldn't they be the same?

**IBM0147** [page 72](#)**Closed** |

Page 61 - table B.8 - line 31 - The statement '(binary zeros)' should be '(i.e., binary zeros)'.

**IBM0148****Rejected** |

*Since we've killed off classic reservations, we don't need to define this.*

SRP does not define any format for the 3rd party device identifier for third party reservations. This needs to be added to comply with requirements in SPC-3.

**IBM0149** [page 59](#)**Closed** |

"See 4.4.3" 4.4.3 is RDMA Read

p50 line 11. "See 4x1" is a typo. I think this should be "See 4.4".

**IBM0150****Closed** |

p50 line 14. "Sever" should be "server".

**IBM0151****Closed** |

p50 line 35. "Sever" should be "server".

**IBM0152****Closed** |

p57 section B.6.5. The descriptions for data-in and data-out are not symmetrical. One is described in terms of an "RDMA READ Request" and the other in terms of "one or more RDMA WRITE packets". I think the rules are the same for both data-in and data-out (please let me know if I'm incorrect in that assumption). Describing them differently implies that they are somehow different, and generates unnecessary confusion. (This is the same as Tivoli comment number 146).

IBM0146

**InfiniBand™ Trade Association comment:**

**IBTA [page 71](#)**

**Closed**

**by William Futral (Intel)**The IBTA Application Working Group understands that the SRP document is out for review and would like to offer the following comment.

The value assigned to I/O Class field in Table B.7 of the SRP document needs to be changed as a result of a change made to the format of this component in the latest InfiniBand(TM) Identifiers Annex, which is a supplement to InfiniBand(TM) Architecture Specification Volume 1.

Attached is a PDF document that contains the new wording in the IBTA Annex (see T10/01-319).

A Class Category needs to be selected for the SRP protocol and inserted in the I/O class field in place of the 0xFF value currently stated. For example, if the Storage Class was selected, the value for I/O class in your Table b.7 would become 0x0100.

Bill Futral  
Application Working Group Co Chair  
InfiniBand Trade Association

**Ophidian Designs comments:****OD1 page 13****Closed**

*May2: **The order in which multiple RDMA Writes without an intervening message are applied to a particular memory location is specific to the RDMA Communication Service.***

*Do we care about iWARP? I think we've decided in the past that we do not.*

*If we cared, and if special precautions were needed, the burden needs to be on the **initiator** device, not the target port, else we've created a requirement that the TP check for overlap.*

**multiple RDMA writes on the same channel store data in order.** Some RDMA communication services (e.g. iWARP) are unable to ensure strict ordering of overlapping RDMA Write operations during normal operation. While methods are available to ensure strict ordering, invoking them for all RDMA Writes would severely affect performance.

SAM-2 does not specify the result of multiple commands to overlapping buffers in most cases. It is unclear whether it specifies the result in any situation (see T10/01-309). Overlapping transfers, also called data overlay, within a single command is unusual enough that some SCSI protocols routinely prohibit it.

This requirement should be removed from SRP. It should be replaced with a statement that overlapping transfers may yield unpredictable results unless the RDMA client (SRP) takes special precautions. The nature of said special precautions, if any, are RDMA communication service specific. A section should be added to clause 5 discussing data overlay to specify that SRP target ports shall take said special precautions whenever data overlay occurs within a command.

**OD2 page 13****Closed**

*First Q: What, completed where? The text should really say that RDMA Read ops may be PROCESSED in any order (at the responder). Approved at May 2 WG.*

**RDMA read operations may complete in any order.** While this states that RDMA Read operations may complete in any order, it is not clear what data they are required to return. See the first example in T10/01-309r0.

If T10/01-309r0 is accepted, this should be clarified to indicate that the data returned by RDMA Read operations need not reflect concurrent RDMA Writes that precede the RDMA Read.

If T10/01-309r0 is not accepted, this should be changed to require that RDMA Reads and RDMA Writes to overlapping locations are strictly ordered for memory access.

**OD3****Rejected/Defer**

*Feb15: Previously discussed - defer to SRP-2.*

Page 14, RDMA channel disconnection

Page 15, Multiple independent RDMA channel operation

Page 16, lines 9 and 10 (list items b and c)

Page 27, SRP\_LOGIN\_RSP response

Page 30, SRP\_I\_LOGOUT request

Page 31, SRP\_T\_LOGOUT request



One of the characteristics of a network or fabric communication service is that errors affecting a channel can rarely be reported using that channel. In the context of SRP, many errors that disconnect an RDMA channel will be reported to one consumer but not the other. The consumer receiving the report cannot use the same RDMA channel to notify the other consumer, as the channel is no longer operational.

It is nonetheless useful for both consumers to know that an RDMA channel has failed. When using multiple independent RDMA channels, the consumers could use one of the other channels to report a channel failure. SRP should be extended to support this. This should be mandatory behavior whenever multiple channels are used between the same SRP initiator port and the same SRP target port. The following paragraphs summarize the changes to SRP to accomplish this.

The SRP\_LOGIN\_RSP response should return a channel handle. The channel handle shall be non-zero and unique among all channels in use on the same I\_T nexus. Zero is valid if and only if the SRP target port only supports one channel per nexus. The channel handle should be a 16-bit field in bytes 28 and 29.

The SRP\_I\_LOGOUT and SRP\_T\_LOGOUT requests should specify an optional channel handle. The channel handle should be a 16-bit field in bytes 2 and 3. If the channel handle is zero, it specifies that the channel on which the request was sent is being logged out; no response is generated. This is identical to the behavior currently specified by SRP. If the channel handle is non-zero then the specified channel is being logged out. A response is generated to confirm the logout and to indicate that all outstanding requests on that channel have been discarded. Targets shall not use of a non-zero channel handle that specifies the channel on which the SRP\_T\_LOGOUT request is sent. Use of a non-zero channel handle that specifies the channel on which the SRP\_I\_LOGOUT request is sent results in target specific behavior.

Extend the discussion of RDMA channel disconnection (page 14) and multiple independent RDMA channel operation (page 15) to require that targets report disconnection using an alternate channel if one is available.

Amend the list of requests that do not have responses on page 16 to say that SRP\_I\_LOGOUT and SRP\_T\_LOGOUT do not have responses when the channel handle is zero, but do have responses when the channel handle is non-zero.

Note that this change cannot be straightforwardly added in an SRP-2. An initiator or target that ignores the channel handle field (because it was reserved in SRP) would logout the wrong channel.

#### OD4 [page 66 tables B.2 and page 67 B.3](#)

**Closed**

*CRS: Agreed Jan to swap GUID, extension. Agreed Feb1 NOT to change to :: format.*

eag: Write more detailed proposal.

HP27

State that initiator port identifier embeds no information -- totally opaque.

*Closed here, handle under HP27 page 66, page 16.*

Target port identifiers may embed information on how to locate the target.

SRP port identifiers for Infiniband are 128-bit identifiers with an embedded GUID (EUI-64). Infiniband GIDs are 128-bit identifiers with an embedded GUID (EUI-64). Unfortunately they are formatted incompatibly. Annex B specifies that the EUI-64 occupies the most significant bytes of an SRP port identifier while the EUI-64 occupies the least significant bytes of an InfiniBand GID or IPv6 formatted address. The bytes not occupied by the EUI-64 are also different.

Having conflicting formats of otherwise equivalent identifiers is guaranteed to lead to interoperability problems. Various people have stated (in SRP working groups) that they expect to identify SRP targets using IPv6 formatted identifiers. SRP should be changed to satisfy this.

A new informative annex should be added recommending that SRP port identifiers adhere to IPv6 address formatting conventions and use one of the three forms listed below. Annex B should require that InfiniBand SRP port identifiers be one of the three forms listed below.

1. The Link-Local prefix (FE80h:0:0:0::/64) concatenated with an EUI-64.
2. The Site-Local prefix (FEC0h:0:0:0::/48) concatenated with 16-bit locally administered value concatenated with an EUI-64.
3. Any value configured manually or by a system management agent.

**OD 5 Pages 4 and 5,****Rejected/Defer**

*Not worth the effort to redo definitions. Review for SRP-2.*

**Glossary terms, and their use throughout the document, Clause 4:** When SRP was proposed and for much of its development no satisfactory glossary of RDMA terms was available. Available external documents used definitions specific to particular implementations. That has recently changed. See the message titled "iWARP Glossary" posted to the yahoo RDMA reflector on September 27, 2001 by Jim Wendt. It would be beneficial if SRP were changed to use the same terms and definitions.

**OD6 Page 11 lines 20-22****Closed**

*Refer to 02-064r4.*

**Normal and solicited message reception:**

- OD6a SRP\_Login\_Req [page 28](#), [page 28](#),
- OD6h SRP\_Login\_Rsp [page 30](#), [page 30](#), [page 31](#)
- OD6b SRP\_TSK\_MGMT [page 37](#), [page 37](#) , [page 37](#)
- OD6c SRP\_CMD [page 40](#), [page 39](#), [page 40](#)
- OD6d SRP\_RSP [page 42](#), [page 42](#)
- OD6e SRP\_T\_LOGOUT [page 35](#), [page 35](#), [page 35](#)
- OD6f SRP\_CRED\_REQ [page 46](#), [page 46](#)
- OD6g SRP\_AER\_REQ [page 48](#), [page 48](#)
- OD6i SRP\_LOGIN\_REJ
- OD6j SRP\_I\_LOGOUT [page 34](#)
- OD6k SRP\_CRED\_RSP [page 47](#)
- OD6l SRP\_AER\_RSP [page 50](#)

This feature is described in the RDMA communication service model, yet not used by SRP. Interrupt mitigation is important in high end systems. Therefore this should be supported by SRP information units. A description of how to do so follows.

Define a bit to be included in all SRP information units. Recommend this be bit 0 of byte 1 and called noturg (notification urgency or not urgent, take your pick).

In initiator to target requests, noturg specifies the notification urgency for the response. The initiator may set it to any value.

In target to initiator responses, noturg specifies the notification urgency. The target shall copy it from the request.

In target to initiator requests, noturg shall be zero. Specify this individually in each request, not as a general rule, so that it may be changed for future requests.

In initiator to target responses, the target shall ignore noturg.

In Annex B, specify that the target shall send information units with solicited event notification enabled if noturg is zero. The target shall send information units with solicited event notification disabled if noturg is one. The initiator shall ignore noturg and send all information units with solicited event notification enabled.

## OD 7

Rejected 28 Nov 2001

*Rob, Cris: reject. Worry about it in the future if/when it's a problem.*

**RDMA communication service specific opcode.** SRP currently requires RDMA Read support for practical operation. However there are RDMA communication services that do not support an RDMA Read. So-called Unreliable Connections on InfiniBand are an example. Note that these have the same reliability characteristics as most existing SCSI protocols (e.g. FCP). Various people have suggested that they would be the most natural service for storage access, except for the lack of RDMA Read. Some VI Architecture implementations also lack RDMA Read.

It is straightforward to emulate an RDMA Read. The target sends a request to the initiator identifying the data to be read. The initiator responds with an RDMA Write supplying the required data, then a response to indicate completion. All that is missing is SRP opcodes that could be used for the request and response.

This is one example of a need for an RDMA communication service specific operation. Others might be required in the future for as yet unanticipated reasons. The purpose of defining this now is to describe proper behavior for an initiator that does not recognize the request.

The following could be defined using a new pair of opcodes or as an extension to the existing SRP\_CRED\_REQ and SRP\_CRED\_RSP. I don't particularly care which is used.

Define a target to initiator request. It is formatted identically to SRP\_CRED\_REQ with the addition of an action code field and action code specific parameters. I recommend a 16-bit action code field. The action code specific parameters may be any length (including zero) provided the total request length is within the limit agreed to during login.

Define the corresponding initiator to target response. It is formatted identically to SRP\_CRED\_RSP with the addition of an action code, an action response code and action code specific parameters. The action code is an echo of the value in the request (could be omitted). The action response code indicates the outcome of the action. Define value zero to designate the action is not supported, all other values reserved. The action code specific parameters may be any length (including zero) provided the total request length is within the limit agreed to during login. If the response code indicates the action was not supported, the action code specific parameters shall be zero length.

OD 8 page 19,

Rejected

*Feb15: Rejected by WG.*

**Data buffer format code and count values:**The combination of a data buffer format code and a data buffer format count is awkward. Their interpretation is interdependent. We really have a single 12-bit field. It would simplify the description (and probably the implementation) if we had a single encoded data buffer format field. The following is a suggested way to encode an 8-bit data buffer format code:

00h	NO DATA BUFFER DESCRIPTOR PRESENT
01h	DIRECT DATA BUFFER DESCRIPTOR
02h – 0Fh	Reserved
1xh	INDIRECT DATA BUFFER DESCRIPTOR
10h	INDIRECT DATA BUFFER DESCRIPTOR WITH NO PARTIAL MEMORY DESCRIPTOR LIST
11h	INDIRECT DATA BUFFER DESCRIPTOR WITH 1 ENTRY PARTIAL MEMORY DESCRIPTOR LIST
12h	INDIRECT DATA BUFFER DESCRIPTOR WITH 2 ENTRY PARTIAL MEMORY DESCRIPTOR LIST
etc.	
1Fh	INDIRECT DATA BUFFER DESCRIPTOR WITH 15 ENTRY PARTIAL MEMORY DESCRIPTOR LIST
20h to FFh	Reserved

These values would occupy bytes 6 and 7 of SRP\_CMD, byte 5 would be reserved.

**Intel comments:**

**intel0001 Sect:1 page 1** **Closed**

Transport protocol s/b 'SCSI Protocol' Suggest shading box to clarify what we're doing in this spec

**intel0002 Sect:1 page 1** **Closed**

Remove 'Physical'

**IBM011 intel0003 page 4** **Closed**

inconsistent use of 'the' before SRP - suggest no 'the'

**intel0004 page 4** **Rejected**

*SAM-2 does...*

Is it necessary to specify field size in definition?

**intel0005 page 4** **Closed**

*Changed sentence to: Data communicated from a client consumer to a server agent or server consumer during RDMA channel establishment (see 4.2) that is meaningful within the client/server application protocol*

'Application protocol' is not defined, thus what constitutes app proto data is unclear

**intel0006 page 4** **Rejected**

*Not significant value in changing.*

Key feature is that data placement is under control of receiver

**intel0007 page 4** **Closed**

*It is, but it's hard to come up with a sufficiently generic replacement.*

'path' is a poor term, implies routing

**intel0008 page 4 (C)** **Closed**

*The software, protocols, and interconnect that provides message and RDMA operations between pairs of consumers (see clause 4).*

'a transport protocol or service' - which is it? There appears to be an abstraction layering problem Using 'service' to define a service suggests we don't have a clean definition - we don't

**intel0009** [page 5](#)**Closed**

*Information provided to an RDMA communication service by a client consumer that allows the RDMA communication service to locate the desired server consumer. The format and interpretation of a server identifier are specific to the RDMA communication service.*

rewrite as 'specific to an RDMA comm service'

**intel0010** [page 5](#) (C)**Closed**

*within an SRP domain.*

TP ID ' within an RDMA comm service' - another abstraction issue - what is a service?

**intel0011** [page 5](#)**Closed**

*Removed 'One byte of'*

Any reason to spec field size?

**intel0012** **Sect:3.3.9** [page 6](#)**Closed**

reported as AN error

**intel0013** [page 8](#) , [page 10](#), (C)**Closed**

**page 10:** *Removed informative/implementation about HOW, and with what information, decisions are made.*

Clause 4 alternates between being a generic overview of RDMA, including discussion of features not used by SRP (e.g., solicited events in 4.3), and being normative (numerous SHALLs), which seems out of place in a clause entitled '...model'

Suggest separating the architectural model from the normative.

**intel0014** [page 9](#)**Closed**

*It was. Removed sentence.*

Seems redundant to Line 10 above.

**intel0015** [page 9](#) (C)**Closed**

See [intel0008](#). Changed def of RDMA CS.

Model is unclear: "A client consumer requests that the RDMA communication service establish an RDMA channel."

[intel0008](#)

But RDMA\_CS is defined as a protocol. The sense should be that the client requests a SERVICE PROVIDER establish a channel.

**intel0016** [page 9](#)**Closed**[IBM022](#)

Duplicate of IBM 022, handled there.

"The request is directed to a server" - Ambiguous

There are several standard meanings for 'server' - a piece of HW, a process, etc.

**intel0017 page 9**

**Rejected**

*No apparent value.*

Should we add 'and validate' to 'Determine'?

**intel0018 page 10 (C)**

**Rejected**

**intel0028** *Doesn't meet the 'thousand word' test, explained well enough.*

We need a similar diagram for channel teardown.

**intel0019 page 10**

**Closed**

*Cap'd 'Channel Establishment'*

(Many places in this clause) Some formatting is needed to set off model-specific terms such as "channel establishment failure response" - suggest bold or small caps. This would make parsing and understanding much easier.

**intel0020 page 10**

**Rejected**

**intel0008** OK after change in def.

Given the vague definition of RDMA CS, it's hard to tell what 'internal to the RDMA communication service' does or does not mean.

**intel0021 page 10**

**Closed**

"An RDMA channel rejected response returns reject data" s/b "Rejection" data

**intel0022 page 10, page 11**

**Closed**

'With SRP the reject data includes' - near duplicate of page 11, Line 2

**intel0023 page 11**

**Closed**

*Rearranged.*

'service specific data' s/b 'service-specific data' (global replace)

**intel0024 page 10**

**Rejected**

*Couldn't think of a better word than acceptable.*

'requests that are acceptable to the RDMA communication service shall be passed to the server agent.' (SHALL in model clause. ) What does it mean to be acceptable to the service? As there is no mapping of 'Server Agent' to any entity, on what is this requirement placed? Can this requirement be stated in SRP or Annex B -specific terms?

**intel0025** [page 11](#)**Rejected**

*No - it will be quite obvious.*

'reject(ion) data shall contain an SRP\_LOGIN\_REJ...' (SHALL) Do we need a subclause similar to '4.5 Ordering and Reliability' to capture size issues, so we can specify requirements on underlying interconnects? (e.g., Must be able to return \_REJ as part of connection establishment protocol.)

**intel0026** [page 4](#) , [page 11](#)**Closed**

'accept data' s/b 'acceptance data'

**intel0027** [page 11](#)**Closed**

*Rearranged sentence.*

It is unclear how an RDMA comm svc requests that a channel be disconnected.

**intel0028** [page 11](#)**Closed**

Need to discuss the case of a channel being destroyed due to an error.

**intel0029** [page 11](#)**Closed**

'A disconnect request causes an RDMA channel to become non-operational.' Is this a request by a consumer to the local CS provider, or to the remote client, server agent,...?

**intel0030** [page 11](#) , [page 10](#) , [page 12](#) , [page 15](#)**Closed**

'may or may not' Since 'May' and 'May Not' are both defined to be equivalent to 'May or May Not', there appears to be no reason to include both. (global)

**intel0031** [page 11](#)**Closed**

Suggest: 'The completion status of operations... is indeterminate.'

**intel0032** [page 11](#)**Closed**

'disconnect request' s/b 'disconnection request' (global)

**intel0033** [page 11](#)**Closed**

*Removed sentence.*

'An RDMA channel may allow its consumers to exchange messages.' One that did not would be useless for the present case, wouldn't it?

**intel0034** [page 11](#)**Closed**

*Now provided.*



'may provide normal and solicited message reception notification,' Since not used by SRP, why included?

**intel0035** [page 11](#)

**Rejected**

intel0035

Corrected by definition change.

'providing the following to an RDMA communication service' Again, CS model issue - how do you provide this to a protocol?

**intel0036** [page 12](#) (C)

**Closed**

*Added : (e.g., an acknowledgment may only signify error-free reception of the data)*

'An RDMA communication service is not required to provide a way for a requesting consumer to determine whether the data has been written into the specified range of addresses in registered memory.' If the target does not know whether a write has completed, how does it know when to send status, and whether status is good or not?

**intel0037** [page 13](#)

**Closed**

'or else disconnect the RDMA channel.' 'destroy' is a better term to reflect the error case.

**intel0038** [page 13](#)

**Closed**

disconnect s/b destroy

**intel0039** [page 14](#)

**Closed**

*NO, but should change match to "is identical to"*

'An SRP target port shall not accept a new RDMA channel unless its SRP target port identifier matches the value in the SRP\_LOGIN\_REQ request.' As we have not defined 'match', do we need to explicitly allow wildcards?

**intel0040** [page 14](#)

**Closed**

Additional - spelling

**intel0041 Sect:5.1.1** [page 15](#)

**Closed**

*Mar 1: SHOULD*

'Prior to requesting that an RDMA channel be disconnected, an SRP initiator port may send an SRP\_I\_LOGOUT' s/b SHALL send

**intel0042 Sect:5.1.1** [page 15](#)

**Rejected**

IBM049

*Mar 1: Stay w/ should*

'Prior to requesting that an RDMA channel be disconnected, an SRP target port should send an SRP\_T\_LOGOUT request' s/b 'SHALL send'

**intel0043** [page 14](#) **Closed** |

'Following acceptance of a login specifying single RDMA channel operation that single RDMA channel' Add comma after 'operation'

**intel0044** **Sect:5.1.3** [page 14](#), [page 33](#) **Closed** |

*CRS: Either use*

0001 0003h Unable to associate RDMA channel with specified I\_T nexus. *or Propose new code -*

*Mar 1: Add new code: RDMA Channel limit reached for this initiator (see 5.1.3)*

*CRS: Correct ref is 5.1.4.*

'shall not accept such a login' What \_REJ reason code is returned?

**intel0045** **Sect:5.1.3** [page 15](#) **Closed** |

identifoer

**intel0046** [page 15](#) **Closed** |

*Removed second half (reservations) - classic reservations have been obsoleted, PRs are I\_\*\_L.*

Break E.g. sentence into two or more sentences, or write as a note.

**intel0047** [page 16](#) **Closed** |

Suggest creating 5.3.1 Initiator Requests, and 5.3.2 Target Requests, to discuss separately. \_Many\_ reviewers have become confused with 'SRP target ports shall limit...' Add pointer to Table 7 and emphasis that these are target-initiated SRP requests, \_not\_ RDMA requests.

**intel0048** [page 16](#) **Closed** |

'credit based' s/b 'credit-based'

**intel0049** [page 17](#) (C) **Closed** |

*Results are are vendor-specific.*

'An SRP initiator port shall not send an SRP request on any RDMA channel whose REQUEST LIMIT has a value less than or equal to zero.' What is Target Port response to this?

**intel0050** [page 17](#) (C) **Rejected** |

*Should be obvious that this is the case.*

'To ensure that task management requests may be sent, an SRP initiator port may choose to send commands only when REQUEST LIMIT is greater than one'

Since TargPort can remove an arbitrary number of credits at any time, Init Port can be prohibited from performing Task Mgmt or sending SRP\_I\_LOGOUT.

intel0051 page 17 (C)

Closed

CPQ007

*Now covered above.*

'An SRP initiator port shall add...whenever it receives an information unit on that RDMA channel' What does 'receive' mean? Received at what layer? There may be a significant delay between receiving and reading.

intel0052 page 17 (C)

Closed

CPQ007

State that target shall not assume initiator has seen or responded to credit change until response is received. For changes that do not have responses (e.g. srp\_rsp), there may be no way target can determine or assume initiator has responded.

When initiator disconnects channel, it shall send logout if positive credit balance. It shall simply disconnect (without logout) if zero or negative credit balance.

Consider sending logout as private data on disconnect? No, don't do that (Randy).

Target behavior is unpredictable if initiator exceeds credit limit.

Target Port maintains, implicitly or explicitly, a value representing its view of the number of free request contexts (Call this Target Request Limit TRL) When there are no requests outstanding, TRL will be equal to the initiator's REQUEST LIMIT (IRL).

The description in 5.3 only describes IRL, but TRL may differ from IRL, and there is no definition of when IRL is changed. Specifically, when TargPort sends SRP\_CRED\_REQ with a negative value, when does TP update TRL? It only makes sense to update upon receipt of SRP\_CRED\_RSP, but that is not stated.

Rewrite to describe with state variable at IP and at TP, and rules for updating.

intel0053 page 17 (C)

Closed

CPQ007

*When TPort rcvs SRP\_CRED\_RSP.*

When can TPort be sure that IPort has seen the REQ\_LIMIT\_DELTA in an SRP\_RSP? (Receipt of transport ACK is not enough)

intel0054 page 17

Closed

*Cris suggested making limits with a guardband. Rob said make limit  $+2^{30}$ , which with worst case race condition means  $-2^{31}$ . ~~Cris wants diagram with examples.~~*

'An SRP target port shall not specify a negative value of REQUEST LIMIT DELTA that might cause REQUEST LIMIT to drop below  $-2^{31}$ ' Given wrapping, it's impossible to drop below  $-2^{31}$  in 32-bit 2's comp. Would  $-2^{16}$  be negative enough?

intel0055 page 17 (c)

Closed

Accept.

'An SRP target port shall account for all possible race conditions to meet these requirements.' Remove this sentence.

**intel0056** [page 18](#)**Rejected**

*Should be clear enough from context.*

'memory segment' and 'memory region' need to be defined before use.

**intel0057 Sect:5.4.1** [page 18](#)**Rejected**

*Byte addresses and offsets are deeply ingrained in the model.*

'identifies the byte address' Isn't the interpretation of a VA up to the particular interconnect/transport?

**intel0058** [page 68](#)**Closed**

(Memory Handle) 'The SRP initiator port shall use this value to locate the region.' It doesn't appear to be within our scope to define initiator memory controller implementations. Remove this sentence.

**intel0059** [page 18](#)**Closed**

Drawing seems to indicate that memory addresses increase moving downward. Should be explicit.

**intel0060** [page 19](#)**Closed**

'SRP target ports shall only issue the appropriate type of RDMA operation for a memory descriptor,' Add: 'depending on whether the descriptor was a DATA-IN or DATA-OUT descriptor'

**intel0061** [page 19](#)**Closed**

'a) The RDMA operations VIRTUAL ADDRESS shall be greater' Should specify STARTING address.

Although VIRTUAL ADDRESS is a field name in Table 1, the field may have a different name in a particular interconnect's request format. Should not be in CAPS.

**intel0062** [page 19](#)**Closed**

'Some data buffer descriptor format code values' s/b 'descriptor formats'

**intel0063** [page 19](#)**Closed**

'use the contents of a count field to further specify the data buffer descriptor format.' specify -> describe

	<b>intel0064</b> <a href="#">page 19</a> , <a href="#">page 20</a> , <a href="#">page 21</a> (C)	<b>Closed</b>
	Added '(i.e., DATA-OUT BUFFER DESCRIPTOR COUNT or DATA-IN BUFFER DESCRIPTOR COUNT)' in several places to clarify.	
	'use the contents of a count field to further specify the data buffer descriptor format.'	
	'count' is essentially a pointer to another field someplace, but this is far from obvious when reading. Suggest we define a format for 'virtual fields', e.g, '*COUNT', or 'vCOUNT', which the reader could easily recognize. Clause 3 would contain a table allowing *COUNT to be looked up as 'SRP_CMD DATA_OUT BUFFER DESCRIPTOR COUNT or SRP_CMD DATA_IN BUFFER DESCRIPTOR COUNT, as appropriate'	
	<b>intel0065</b> <a href="#">page 19</a>	<b>Closed</b>
CPQ008	Remove period after PRESENT	
	<b>intel0066</b> <a href="#">page 19</a>	<b>Closed</b>
CPQ009	(DUPLICATE OF CPQ 09)	
	Note 'b' is not referenced above, probably s/b on 'count'	
	<b>intel0067</b> <a href="#">page 19</a>	<b>Closed</b>
edit010		
	'initiator port may specify in SRP_CMD requests (see 6.8) sent on that RDMA channel. An SRP initiator port shall not specify a data buffer descriptor format that was not indicated in the REQUIRED BUFFER FORMATS field value for that RDMA channel. ' What is target response if it does?	
	<b>intel0067a</b> <a href="#">page 19</a>	<b>Rejected</b>
	'SRP target ports are not required to check SRP_CMD requests for data buffer descriptor formats that were not indicated in the REQUIRED BUFFER FORMATS field value.' Not clear - are they required to validate that they did a valid format?	
	<b>intel0068</b> <a href="#">page 20</a>	<b>Closed</b>
IBM078	'An SRP target port may accept an RDMA channel and' s/b 'channel establishment request'	
	<b>intel0069</b> <a href="#">page 20</a>	<b>Closed</b>
IBM079	shall reject the RDMA channel and return after channel, add 'establishment request'	
	<b>intel0070</b> <a href="#">page 20</a>	<b>Closed</b>
	<i>Used bit field name consistently, removed explanatory wording except for first appearance. Did same for DDBD.</i>	

indirect data buffer descriptor (IDBD)  
Use caps or formatting to set off these field names

	<b>intel0071</b> <a href="#">page 20</a>	<b>Closed</b>
IBM084	if the SRP initiator port may specify the INDIRECT s/b 'if the TP will accept...'	
	<b>intel0072</b> <b>Sect:5.4.2.2 Pg:19 Ln:18</b>	<b>Rejected</b>
	<i>Issue went away.</i>	
IBM084	does not use (Sense is that IP forebears use of indirect) shall not use?	
	<b>intel0073</b> <a href="#">page 20</a>	<b>Closed</b>
	'sixteen bytes' Previously defined in Table 2 - eschew multiple definitions	
	<b>intel0074</b> <a href="#">page 21</a>	<b>Closed</b>
	target port shall only issue RDMA Read operations using the memory descriptor contained in the direct data buffer descriptor. Statement does not have desired effect - limits what you can read, but does not limit accesses to READs. s/b 'shall issue only RDMA Reads when using'	
	<b>intel0075</b> <a href="#">page 21</a>	<b>Closed</b>
	shall issue only RDMA Writes...	
	<b>intel0076</b> <a href="#">page 21</a>	<b>Rejected</b>
	format code value 'value' appears to be superfluous	
	<b>intel0077</b> <a href="#">page 21</a>	<b>Closed</b>
	Added xref to table 2. 'The length....sixteen bytes.' Drop sentence - redundant to Table 2	
	<b>intel0078</b> <a href="#">page 21</a>	<b>Rejected</b>
	<i>As we proceed to describe it, the context appears sufficient.</i> 'An indirect data buffer is comprised of one or more memory segments' Need a real definition.	
	<b>intel0079</b> <a href="#">page 21</a>	<b>Closed</b>
	segments may or may not be contiguous. s/b 'may be discontinuous'	

	<b>intel0080</b> <a href="#">page 21</a>	<b>Closed</b>
	remove 'may be in a single memory region'	
	<b>intel0081</b> <a href="#">page 21</a>	<b>Closed</b>
	of the memory segments (ADD: listed in an IBDB)	
	<b>intel0082</b> <a href="#">page 21</a>	<b>Closed</b>
	<i>Added: "supported by the RDMA communication service"</i>	
	may have any length As the length field is finite, so is the segment length	
<a href="#">CPQ012</a>	<b>intel0083</b>	<b>Rejected</b>
	<i>Explained in next sentences.</i>	
	value contained in the data buffer descriptor's count field. Implies that the field is contained within the DBD	
	<b>intel0084</b> <a href="#">page 22</a>	<b>Rejected</b>
	<i>Mar 1: PMDL was Ed's original idea. Spec stability may be more important. Revisit after other 'count' changes made.</i>	
	'count' Suggest replacing with 'PMDL Length'	
<a href="#">IBM092</a>	<b>intel0085</b>	<b>Closed</b>
	Fixed by earlier rev.	
	DESCRIPTOR field value is a memory descriptor Suggest: DESCRIPTOR field contains a memory descriptor	
<a href="#">IBM092</a>	<b>intel0086</b>	<b>Closed</b>
	concatenated together 'together' is redundant Stamp Out and Abolish Redundancy!	
	<b>intel0087</b> <a href="#">page 21</a>	<b>Rejected</b>
	contains the number of memory descriptors in the indirect table times sixteen.	
	Suggest: contains the length, in bytes, of the indirect table (16 bytes * number of descriptors in table)	
	<b>intel0088</b>	<b>Closed</b>
	<i>Already fixed.</i>	
	MEMORY DESCRIPTOR field value contains any other drop 'value'	

**intel0089** [page 22](#)

Closed

'n'

list of n memory descriptors Use bold or something to set off n

**intel0090** [page 22](#)

Closed

shall only issue s/b shall issue only

**intel0091** [page 22](#)

Closed

shall only issue s/b shall issue only (also Ln 4)

**intel0092** [page 23](#)

Closed

All four..., each might..., or several might be...

Awkward - generalize to: segments may be in different memory regions

**intel0093**

Closed

IBM092

Fixed earlier.

value contains Drop: value ( i.e., ) Add: in bytes

**intel0094 Sect:6.1** [page 26](#), [page 46](#), [page 48](#), [page 50](#)

Closed

*Only possible Os are SRP\_CRED\_REQ and SRP\_AER\_REQ.**Mar 1: All are mandatory. Make sure spec says so.**Added statement, removed other text on IU pages about mandatory status.*

Add M/O column, or statement that all are mandatory.

**intel0095 Sect:6.1 Pg:23 Ln:24**

Closed

Add space between Tables 6 and 7 to clarify distinction between I&gt;T and T&gt;I requests.

**intel0096 Sect:6.1** [page 27](#), [page 36](#)

Closed

*There is a code for bad type. Do we need one for "bad length for type"?*

IBM087

*Mar1: Yes.*

shall send SRP\_T\_LOGOUT What reason code?

**intel0097** [page 27](#)

Closed

Need to define requestor, responder. Much reviewer confusion wrt Targ as requestor.



**intel0098 page 27 (C)****Closed**

Reject: If an initiator sends duplicate tags, target behavior is unpredictable. It is a non-goal to operate predictably in such conditions. Such behavior means the initiator is broken; it should be fixed. Add statement that target behavior is unpredictable. "If tag values are not unique, responder behavior is unpredictable".

Responders are not required to check whether the TAG values of outstanding SRP requests are unique. Since duplicate tags would likely cause a credit leak (one response for two requests), this could lead to deadlock, as InitReqLimit and TRL would be out of sync. We either need to require verification of uniqueness, or provide a ReqLimit re-sync mechanism.

**intel0099 page 28****Closed**

*as login data*

shall only be sent during RDMA s/b: shall be sent only during RDMA

**intel0100 Sect:6.2 Pg:24 Ln:41****Closed**

CPQ014

maximum length Add: in bytes

**intel0101 Sect:6.3 Pg:27 Ln:4****Closed**

*shall be sent as*

shall only be sent s/b: shall be sent only

**intel0102 Sect:6.3 Pg:27 Ln:40****Closed**

CPQ018

maximum length Add: in bytes

**intel0103 page 26, page 30 (C)****Closed**

*Reduced SRP\_RSP and SRP\_AER\_REQ to 36 bytes, added notes that such was useless.*

edit007

*Accept, double check arithmetic (srp\_aer\_req vs. srp\_rsp). edit007 page 43 , page 43, page 49, page 49 removes four-byte rounding on Sense Data.*

*SPC: Device servers shall be capable of returning eighteen bytes of data in response to a REQUEST SENSE command. \_rsp needs 36+18 = 54, \_aer\_req : 36+18 = 54*

*52 or larger AER\_REQ requires 54 -> 56*

**intel0104 Sect:6.4 Pg:29 Ln:3****Closed**

OD6i

a(n) SRP target

**intel0105 page 33****Closed**

intel0175

too large / Need a way to specify, so that Init does not have to guess

	<b>intel0106</b> <a href="#">page 34</a>	<b>Closed</b>
<a href="#">intel0109</a>	<i>Need new subclause for 'behavior'. To 4.3 or 4.5, add ACK/timrout wording. (This comment initially attached to T_LOGOUT, not I_LOGOUT) (NEW SHALL)</i> "delay a vendor specific time" s/b Wait for transport ACK or timeout error	
	<b>intel0107</b> <a href="#">page 35</a> (C)	<b>Rejected</b>
<a href="#">edit018</a> ,	<i>WG rejected EAG's proposal for cross-channel reporting, so this is moot, sentence will be removed.</i> An SRP_T_LOGOUT request may also be used to notify the SRP initiator port that an RDMA channel has failed, rendering it non-operational. / If the channel has failed, it won't be able to carry this IU. <del>We DO need a way to report failures.</del>	
	<b>intel0108</b> <a href="#">page 36</a>	<b>Rejected</b>
	<i>Probably, but these should be self-explanatory.</i> There are no references in spec to reason codes 2,3, 6-9. Do we need some SHALLs pointing to them?	
	<b>intel0109</b> <a href="#">page 36</a>	<b>Closed</b>
<a href="#">intel0106</a>	<i>See also: <a href="#">page 15</a> (NEW SHALL)</i> delay a vendor... Reference: xport ack or timeout	
	<b>intel0110</b> Sect:6.8 Pg:34 Ln:14	<b>Rejected</b>
	COUNT Change to PMDL Length	
	<b>intel0111</b> <a href="#">page 39</a>	<b>Closed</b>
	Add ref a,b to notes below	
	<b>intel0112</b> Sect:6.9 Pg:36 Ln:36	<b>Rejected</b>
	Since SENSE DATA length is 7 bytes + a one-byte length field, at least the top two bytes / b reserved. We may want to have this field be that one-byte length field, with 7 assumed, as in SPC.	
	<b>intel0113</b> <a href="#">page 44</a> , <a href="#">page 45</a>	<b>Closed</b>
	length of the...buffer Ref 5.4 for length determination	
	<b>intel0114</b> <a href="#">page 43</a>	<b>Closed</b>
	indicates (that) the contents ....shall be ignored and (that) the	

**intel0115 Sect:6.9 Pg:37 Ln:26****Rejected**

The(value of the) SENSE DATA LIST LENGTH field (be a multiple of four).

**intel0116 Sect:6.9 Pg:37 Ln:26 (C)****Rejected**

reject: actual sense data length is in sense header.

SENSE DATA LIST LENGTH shall contain the length of the truncated SENSE DATA field. This is at odds with SPC-2, which returns the total length. How would you know that you had missed some Sense Data?

**intel0117 page 44****Closed**

4 -> four, added reference to Table 23

shall contain a length of 4 Also defined in Table 23 - refer to table instead

**intel0118 Sect:6.9 Pg:38 Ln:17****Closed**

IBM0119

structure eqn as DOBL - (offset + 1) Much easier to understand (global change to all similar eqns) Formatting - more white space above and below, use bold font

**intel0119 page 44****Closed**

may or may not not is the more worrisome case (more so for Ln 25)

**intel0120 page 44****Closed**

Some commands may have a non-zero residual Add: e.g., INQUIRY

**intel0121 page 45****Closed**

may not

**intel0122 Sect:6.9 Pg:39 Ln:1****Rejected**

*Other options also awkward - leave it.*

certian (SRP) protocol errors

**intel0123 Sect:6.9 Pg:39 Ln:18****Closed**

*Drop NO FAILURE. Same as FCP.*

Would there ever be a case where a RSP of NO FAILURE was returned?

**intel0124 Sect:6.9 Pg:39 Ln:31****Rejected**

sense data shall be presented presented s/b returned Also Ln 32,33

**intel0125 Sect:6.9 Pg:39 Ln:33** **Rejected**

*Too awkward.*

whose Use whose wrt people only

**intel0126 Sect:6.9 Pg:39 Ln:30** **Rejected**

*Annex C gone. No change.*

SPC-2 Annex C references SPC-3 - which?

**intel0127 Sect:6.11 Pg:40 Ln:43 (c)** **Closed**

See comments on 5.3 for CRED\_RSP issues

**intel0128 Sect:6.12 Pg:41 Ln:31** **Rejected**

Don't need four bytes for SENSE data length (7 + 1 byte)

**intel0129 Sect:6.12 Pg:41 Ln:43** **Rejected**

The (value of) the SENSE DATALen field (shall be a multiple of four.)

**intel0130 page 49 (C)** **Closed**

*Shall not be allowed - Removed sentence.*

If no sense data is provided, What would the point be - to force Init to issue Req Sense Request? Should this be allowed?

**intel0131 Sect:6.12 Pg:42 Ln:1** **Rejected**

SENSE DATA LIST LENGTH shall contain the length of the truncated SENSE DATA field.  
Appears to violate SPC-2.

**intel0132 Sect:6.12 Pg:42 Ln:7** **Rejected**

presented s/b (returned in response to)

**intel0133 page 52** **Closed**

The following subclause defines the fields in the disconnect-reconnect mode Nope - same subclause

**intel0134 Sect:7.2 page 52** **Closed**

Gray-out or mark as Reserved the fields that are reserved for SRP. There's a lot of noise for the two fields that are used...

**intel0135 Sect:7.2 Pg:44 Ln:1** **Closed**

SRP devices shall only use (the) disconnect-reconnect page parameter fields Use formatting for disconnect-reconnect

**intel0136** **Rejected**

*Not part of the D-R page.*

SRP devices shall only use ...fields defined below. What about the standard mode page header fields?

**intel0137** **Closed**

*Split 7.2 into Valid and invalid field sections, said that I and T shall set to zero.*

"field shall not be implemented by SRP target ports"

Define in terms of behavior, not implementation. Appears to have been covered by para above.

**intel0138 [page 53](#)** **Closed**

If the EMDP bit is set to 0, the SRP target port shall generate (RDMA requests with) continuously increasing () addresses for a single SCSI command.

**intel0139 [page 53](#)** **Closed**

*Removed.*

affect the order of frames within an RDMA. What's a frame? Within an RDMA what?

**intel0140 Sect:7.2 Pg:44 Ln:24** **Rejected**

**intel0141 Sect:7.2 Pg:44 Ln:24** **Rejected**

They are indeed wrong, but are defined by SPC.

*protocol specific s/b protocol-specific (also Ln 27)*

**intel0142 [page 53](#)** **Closed**

LUN -> PORT

**intel0143 Sect:A.1 Pg:45 Ln:11** **Closed**

Top right box s/b Device Server?

	<b>intel0144</b> <a href="#">page 54</a>	<b>Closed</b>	
	four step, two step s/b four-step, two-step (global)		
	<b>intel0145</b> <a href="#">page 55</a>	<b>Closed</b>	
<a href="#">IBM0129</a>	Need close paren after initiator		
	<b>intel0146</b> <b>Fig A.3</b>	<b>Closed</b>	
	Close paren		
	<b>intel0147</b> <a href="#">page 56</a>	<b>Closed</b>	
	<i>Removed redundant text (pasted from somewhere?).</i>		
	"See table A.1 for the definitions of the names used within "		
	Don't see names there - objects?		
	<b>intel0148</b> <b>Sect:A.4.1 Pg:48 Ln:44</b>	<b>Closed</b>	
	Use bold for EXECUTE COMMAND		
	<b>intel0149</b> <a href="#">page 62</a>	<b>Closed</b>	
	IBTA uses caps for G S I		
	<b>intel0150</b> <a href="#">page 62</a>	<b>Closed</b>	
	<i>added 'globally unique' to defn.</i>		
	Do we need to define, spell out GUID?		
	<b>intel0151</b> <a href="#">page 62</a>	<b>Closed</b>	
	Ports also present on switches.		
	<b>intel0152</b> <a href="#">page 63</a>	<b>Closed</b>	
	Speel out QP, use IBTA definition.		
	<b>intel0153</b> <a href="#">page 63</a>	<b>Closed</b>	
	IBTA uses caps for R T U		
	<b>intel0154</b> <b>Sect:B.4 Pg:54 Ln:50 (C)</b>	<b>Closed</b>	
<a href="#">edit001</a>	Each IB GID is globally unique, Not true - see IBA Vol 1 4.1.1		

**intel0155 Sect:B.4 Pg:55 Ln:17** **Closed**

worldwide Varies - see IBA Vol 1, 4.1.1

**intel0156 page 66** **Closed**

An SRP initiator device is one or more IB consumers may consist of

**intel0157** **Closed**

**IBM0137** The GUID field should (be) an IB GUID available to the SRP initiator port, Must it be a GUID, an IB GUID, ....?

**intel0158 page 66** **Rejected**

*Unless otherwise stated, the whole universe. Since init is starting with a GUID, it shouldn't be too hard.*

"The IDENTIFIER EXTENSION field shall be chosen by the SRP initiator port to ensure that all SRP initiator port identifiers are unique."  
Over what domain?

**intel0159** **Closed**

*Handle under edit027.*

**edit027** [containing] the SRP target port. providing?

**intel0160 page 66** **Closed**

*SDS includes the protocol, so this picture can't show the SDS, but it shows the RDMA CS quite well. Widened gray box to include QPs. **Changed Svc Del Subsys to RDMA Comm Svc.** Added 'and software' to list of components below.*

*What is distinction between fabric and components thereof?*

*Given SAM-2 ambiguity on what SvcDelSys is, it's hard to resolve this.*

The service delivery subsystem contains queue pairs, IB channel adapters, IB ports, and the InfiniBand TM Architecture fabric.

Contains exclusively? How does this map to Clause 4 RDMA Comm Service?

**intel0161 page 67** **Closed**

general service interface IBTA uses caps

**intel0162** **Closed**

/(breaks across page) O Remove slash from FRAME list of characters for line breaks.

**intel0163** [page 67](#) **Closed**

"open IBA connections"  
use establish instead

**intel0164** [page 68](#) **Closed**

*Used CODE formatting.*

Port and CM Redirection or Port Redirection. Very hard to parse - use bold or underscores inside the names

**intel0165** [page 68](#) **Closed**

*Must fix.*

SRP\_LOGOUT IU list as T\_LOGOUT, I\_LOGOUT or define as a virtual field

**intel0166** **Closed**

CM disconnect request use caps -it's not generic

**intel0167** [page 68](#) **Closed**

*Created new heading 'Errors', moved ref'd text there, corrected. Added SHOULD.*

The sender may disconnect if its send queue has transitioned to (THE) error state.  
What do you mean by disconnect here - local action?

**intel0168** [page 68](#) **Closed**

*Send DREQ or wait for other side to.*

The receiver of an SRP\_LOGOUT IU shall respond with an InfiniBand TM Architecture transport acknowledgement and disconnect.  
Destroy QP, send DREQ, ...?

**intel0169** **Closed**

[edit025](#)

to an ... RDMA READ Request. One or more requests.

**intel0170** [page 69](#) **Closed**

WRITE packets WRITE requests

**intel0171** **Sect:B.7 Pg:58 Ln:37** **Closed**

outcommands

**intel0172** **Closed**

[edit002](#)

Why list ChangeID and OptionROM to say we don't care about them?  
2 July 2002



**intel0173 Sect:B.7 Pg:60 Ln:23 (c)****Rejected**

*Too hard to do in a dynamic environment.*

Send Message Depth Reserved -> Maximum Initiator Request Limit This allows initiators to efficiently allocate buffers

**intel0174 Sect:B.7 page 71 Ln:24 (c)****Closed**

RDMA Read Depth reserved -> Maximum IOC-issued RDMA depth Allows inits to efficiently allocate RDMA resources

**intel0175 Sect:B.7 page 71 Ln:26 (c)****Closed**

Send Message Size rsvd -> MAXIMUM INITIATOR TO TARGET IU SIZE Eliminates need to guess this value

**intel0176 Sect:B.7 page 71 Ln:46 (c)****Closed**

This field is expected to be marked obsolete in future versions of the Architecture Not for T10/ANSI to say InfiniBand TM

**intel0177 page 72****Closed**

*Added 'literal' to note.*

Is :reserved a literal? If not, express as :zzzz, explain below that it is reserved.

**intel0178 page 72****Rejected**

No references to Table notes.

**intel0179 page 72****Closed**

padded s/b extended

**Texas Instruments comment:**

This has the appearance of a draft copy, not a final review copy. Change bars and line numbers should not be on a letter ballot document.

**Troika Networks comment:**

**Troika Networks, Inc.:** [page 32](#)

**Closed**

*Table 13 changed to C2h.*

The TYPE code value of 80h in tble 13 is incorrect according to table 6 and should be value C2h.

**Woven Electronics comment:**

**Woven Electronics:**

Can not Contribute

**Rejected**

**New editor comments:****edit001** [page 62](#)**Closed**

IB GUID: A port address used for directing packets between IB subnets. An IB GUID is a 128-bit value that conforms to the IPv6 address format. See Infiniband™ Architecture Specification Volume 1 Release 1.0.a

*Some GUIDs are subnet-local, and thus fail the 'directing packets between IB subnets'. Suggest removing first sentence.*

**edit002** [page 70](#), [page 71](#)**Closed**

*Add a footnote to the table saying it means "does not change or override IB reqmts": This protocol does not change or override InfiniBand Architecture requirements on the values of fields not listed, or for those marked as having 'no requirement'.*

Should we remove the '**no requirement**' statements from B.6 and 7, and replace with a statement that if not mentioned, SRP places no requirements? This avoids the appearance of overriding IBA specs, which may place requirements on them.

**edit003** [page 65](#)**Closed**

*Change LID description from "Address assigned by the IB subnet manager to each IB port" to "Local routing address assigned to each IB port by the IB subnet manager"*

**edit004** [page 66](#)**Closed**

[intel0160](#) May2: "includes", move to under figure.

[IBM0143](#) This seems an odd place to hide architecture model mappings. Move to a more appropriate place or remove.

**edit005** [page 16](#)**Closed**

*Added Alias associations action to clause 5: 'There are no events specific to this protocol that clear alias associations (see SPC-2).'*

*Will be considered at Mar13 CAP meeting.*

SPC-3 says "These [alias] associations shall be cleared under any event that resets the logical unit and *events designated by the SCSI protocol.*" It appears that we need to have a list or a statement that there are no such events. Where would it go?

**edit006** [page 45](#)**Closed**

*Added to reserved list*

RSP\_CODE 06h is not covered in table.

**edit007** [page 43](#) , [page 43](#), [page 49](#), [page 49](#)**Closed***Accepted Mar 14.*[intel0103](#) Remove Sense Data Length four-byte rounding.**edit008** [page 15](#)**Rejected**

Although the target port is required to abort requests upon disconnect, logout, etc., there is no specification of the **order** in which tasks are to be aborted. This may result in a race condition. For example, if the target port issues ABORT TASK requests in the order oldest-to-youngest, a newer task could begin execution once an older task was aborted. There could be undesirable side-effects if (e.g.,) the older task had been issued with the Ordered task attribute to ensure that the task completed before the younger task began execution.

Proposed: Tasks shall be aborted from youngest to oldest.

**edit009****Rejected***True. What are you going to do?*

Since a logical unit would not have knowledge that an initiator was accessing it over multiple RDMA channels, it appears that a deferred error could be reported on any channel of the I\_T nexus. This appears to include errors for commands that were issued on channels that have since been disconnected.

**edit010** [page 19](#)**Closed**[intel0067](#)

Although Targ Port is not required to check data buffer format, we need to say how it handles the detection of a bad one (T\_LOGOUT with codes XXX, as appropriate). Change from 'not required to check', to 'should check'?

**edit011** [page 20 C](#)**Closed***Check formatting*

Need to specify what REJECT code Targport shall return.

**edit012** [page 13](#)**Closed***in this subclause*

"If an RDMA communication service is unable to meet these requirements " THESE is ambiguous. Move to 4.5.1, make in "in this subclause"?

**edit013** [page 13](#)**Closed**

*No - "Messages sent on an RDMA channel shall be delivered"*

"Messages sent {by the same consumer} on the same RDMA channel shall be delivered to the receiving consumer in the order they were sent."

is there any reason to say "by the same consumer"?

**edit014** [page 5](#)

**Closed**

Need to define:

~~server~~ (not used alone)

server agent

~~server consumer~~ (clear from consumer)

~~application protocol~~

~~application protocol data~~

~~consumer~~ (already done)

,

**edit015** [page 55](#)

**Closed**

CONSUMER

Server Agent != Target Port

**edit016** [page 35](#), [page 43](#), [page 43](#), [page 46](#), [page 48](#)

**Closed**

*Reworded some, kept some to create subordinate clauses*

Remove instances of 'Otherwise'

**edit017** [page 71](#)

**Closed**

*Accepted at Apr15 concall.*

Change Table B.7 fields "Service Connections", "Initiators supported" to "No requirement". Remove (a) from 'Controller Services Capability Mask', move to No Req.

edit002

Remove "No Requirement" and "Reserved", fields add note that SRP does not specify requirements for fields not listed, and that their usage should follow the IBA spec.

**edit018** , [page 26](#), [page 34](#)

**Closed**

intel0107

Second part of SRP\_T\_LOGOUT description is "RDMA channel failure notification". Since we have no way to say one channel that another channel has died, this should be removed. Same for I\_LOGOUT.

**edit019** [page 36](#)

**Closed**

*Change to: SRP initiator port sent response (see Table 8) with no corresponding SRP target port request(see Table 7) outstanding.*

T\_LOGOUT code 03h: "Valid response type code with no corresponding SRP target port request outstanding" is unclear.

**edit020 page 4,** **Closed**

*Added hyphen or reworded, usually saying 'specific to'*

Hyphenate "xxx specific",

**edit021 page 53** **Closed**

*New text: "A value of zero indicates that the maximum transfer size is limited only to that of the underlying interconnect."*

"0 indicates there is no limit on the amount of data ", but IB is limited to 2<sup>31</sup>bytes.

**edit022 page 54** **Closed**

If talking about application protocol, we need to mention command specs.

**edit023 page 16** **Closed**

*Add xrefs to appropriate 6.1 tables.*

**edit024 page 62, page 62** **Closed**

CPQ039

*Not in T10 style guide. Have sent Q to H Rosenfeld, ANSI.*

*Answer: Define acronym, add tm note.*

" See Infiniband™ Architecture Specification Volume 1 Release 1.0.a" takes up way too many bits. If we can say SAM-2, is there any reason we can't say IBA, or something?

**edit025 page 68** **Closed**

"Shall map... receive data-out...to an RDMA READ"

Should be "one or more", not least because of Control Mode Page MAX BURST SIZE.

**edit026 page 63** **Closed**

*Added to GID, IOC, LID, MAD, QP.*

Add 'IB' to abbreviation definitions for IB-specific terms.

Bro013

**edit027 page 67** **Closed**

Bro010

*May2: Provide.*

Bro011

Do IOCs CONTAIN or PROVIDE SRP target ports?

intel0159

**edit028 page 72** **Closed**

*Approved May2: "A service name that identifies an SRP target port shall meet the rules described in this table."*



*Recognized by whom? How about "only if"? Proposed:  
A service name identifies an SRP target port only if it satisfies all of the rules described in this table.*

**edit029 page 62****Closed**

*Added B.3.1 (ntroduction definitions and abbrevs): "The definitions in B.3.2 and the abbreviations in B.3.3 are incomplete without reference to IBAS." Removed multiple 'See IBAS'.*

Intead of saying "See IBAS" on amost every defn, add a note saying that for a full understanding of the terms, refer to IBAS.

**edit030 page 13****Closed**

*Propose: Use of this protocol over a communication service not meeting the requirements of 4.5 is outside the scope of this standard.*

*Approved May2: If an RDMA communication service is unable(fails?) to meet the ordering requirements of this subclause on an RDMA channel, it shall disconnect the RDMA channel.*

The statement

**"If an RDMA communication service is unable to meet these requirements on an RDMA channel, it shall disconnect the RDMA channel."**

places a burden of intelligence on the interconnect, when it should be on the initiator.

**edit031 page 11****Closed**

*An RDMA communication service may provide a facility known as solicited message reception notification, by which some messages may be marked by the sender to indicate to the recipient that the marked message is more urgent than a message that is not marked. How such a marked message is handled by the recipient is outside the scope of this standard.*

Normal/solicited messaging is vague. It is not clear which is more urgent, normal or solicited, or if such is always the case.

**edit032 page 27****Closed**

"shall contain a TAG value that is unique among all the outstanding SRP requests from a particular initiator port. " With multiple channels, this needs to apply to TargPorts as well.

**edit033 page 20****Closed**

INDIRECT -> DIRECT

An SRP initiator port sets the DDBD (direct data buffer descriptor) bit to one in a SRP\_LOGIN\_REQ request (see 6.2) if it requires that the target port support the ~~INDIRECT~~ DATA BUFFER DESCRIPTOR format.

**edit034 page 59****Closed**

*RDMA transfers are typically performed by hardware without the intervention of the client consumer*

Add note that RDMA happens on behalf of client consumer.

**edit035** [page 12](#)

**Closed**

*(e.g., an acknowledgement may indicate only that a message was received without error)*

Elaborate on point: 'may not provide a way for a sending consumer to determine whether a message has been delivered to the receiving consumer'

**edit036** [page 13](#)

**Closed**

*'Different consumers' is unnecessary. On one channel, all is ordered, none across.*

"Messages sent on different RDMA channels or by different consumers... "

**edit037** [page 14](#)

**Closed**

'parameter' is unnecessary

**edit038** [page 15](#)

**Closed**

'between the same' 'same' is unnecessary in several places.

**edit039** [page 52](#)

**Closed**

*Vas ist zis 'SRP Interface'? By the text, the mode page controls the SRP Target Port (send page to dev server, which magically sends to TP.) Changing to SRP target port.*

'The application client passes the fields used to control the SRP interface'

**edit040** [page 14](#), [page 15](#)

**Closed**

*Moved 5.1.2 RDMA Channel Disconnection below single and multi-channel operation. Now 5.1.4. Text refs SPC-3 .*

IBM050

*Text associated with [IBM050 PDF](#) page 16 must stay to handle multichannel case.*

IBM050

I\_T nexus loss