

Date: April 26, 2001

To: T10 Committee (SCSI)

From: George Penokie (Tivoli)

Subject: Defination of Well Known Logical Units

1 Overview

This proposal defines an extension to logical unit addressing that would allow definition of a logical unit that does specific functions. The commands these special logical units would be primary used for carrying out functions that are not contained within the boundaries of the logical unit. Any device that accepts a well known logical unit number would be required to support every command defined for that specific well known logical unit.

2 Terminology

2.0.1 Well known logical unit: A logical unit that only does specific functions. If a well known logical unit is supported within a SCSI target device then that logical unit shall support all the commands associated with it. Well known logical units allow an application client to issue requests to receive specific information usually relating to a SCSI target.

2.0.2 SCSI protocol device: A device that routes SCSI tasks and task management functions between SCSI initiator devices and SCSI target devices. A SCSI protocol device may connect SCSI devices that have the same protocol (e.g., fibre channel-to-fibre channel) or different protocols (e.g., InfiniBand (TM)-to-fibre channel).

2.0.3 intermediate port server: A well-known logical unit that manages all the ports on a SCSI protocol device.

2.0.4 target server: A well-known logical unit that manages all the ports and logical units within a SCSI target device.

3 Discovery

One of two methods could be used for discovering well known logical units. The preferred method would be to access the well know logical unit that would accept the REPORT LUNs command. Another method would be to return the information on a REPORT LUNs command to LUN zero. In either case the REPORT LUNs command needs to have a new field defined as follows:

Table 1 - REPORT LUNS command

Bit Byte	7	6	5	4	3	2	1	0	
0	OPERATION CODE (0Ah)								
1	RESERVED						SELECT REPORT		
2	RESERVED								
3	RESERVED								
4	RESERVED								
5	RESERVED								
6	(MSB)								
7									
8	ALLOCATION LENGTH								
9							(LSB)		
10	RESERVED								
11	CONTROL								

The SELECT REPORT field contains the information on which logical unit addresses shall be reported. See table 2 for the defined states.

Table 2 - SELECT REPORT

Codes	Description
00b	The list of logical units shall not contain any well known logical units
01b	The list of logical unit shall only contains well known logical units, if any.
10b	The list of logical units shall contain all logical units.
11b	Reserved

4 LUN structure

An application client selects a well known logical unit using LUN extended addressing LUN. See xxx for the LUN format.

Table 3 - Format of addressing fields

Bit Byte	7	6	5	4	3	2	1	0
n-1	ADDRESS METHOD		(MSB)					
n	ADDRESS METHOD SPECIFIC							(LSB)

The ADDRESS METHOD field defines the contents of the ADDRESS METHOD SPECIFIC field. See table 4 for the address methods defined for the ADDRESS METHOD field. The ADDRESS METHOD field only defines address methods for entities that are directly addressable by an application client.

Table 4 - ADDRESS METHOD field values

Code	Description	Clause
10b	Logical unit addressing method	xxx
00b	Peripheral device addressing method	xxx
01b	Device type specific	
11b	Extended addressing	xxx

4.1 Extended addressing

Extended addressing allows for more address methods to be defined for the 8 byte LUN. These may include additional 2 byte formats or formats that use more than 2 bytes. See table 5 for the format of the 2 byte EXTENDED ADDRESS METHOD field and table 6 for the format of the 8 byte EXTENDED ADDRESS METHOD field.

Table 5 - Format of 2 byte extended addressing fields

Bit Byte	7	6	5	4	3	2	1	0
n-1	1	1	LENGTH	EXTENDED ADDRESS METHOD				
n	EXTENDED ADDRESS METHOD SPECIFIC							

Table 6 - Format of 8 byte extended addressing fields

Bit Byte	7	6	5	4	3	2	1	0
0	1	1	LENGTH	EXTENDED ADDRESS METHOD				
1	EXTENDED ADDRESS METHOD SPECIFIC							
7	EXTENDED ADDRESS METHOD SPECIFIC							

A length (LENGTH) bit of zero indicates the EXTENDED ADDRESS METHOD SPECIFIC field is 1 byte in length. A LENGTH bit of one indicates the EXTENDED ADDRESS METHOD SPECIFIC field is 7 bytes in length.

The EXTENDED ADDRESS METHOD field defines the contents of the EXTENDED ADDRESS METHOD SPECIFIC field. See table 4 for the address methods defined for the EXTENDED ADDRESS METHOD field. The EXTENDED ADDRESS METHOD field only defines address methods for entities that are directly addressable by an application client.

Table 7 - EXTENDED ADDRESS METHOD field values

LENGTH	Code	Description	Subclause
0 or 1	00000b	Reserved	
0	00001b	Well known logical unit	4.2
1	00001b	Reserved	
0 or 1	00010b - 11111b	Reserved	

4.2 Well known logical unit addressing

A SCSI target device may support zero or more W-LUNs however a single SCSI target device shall only support one instance of each supported well known logical unit regardless of the number of target ports allow access to the well know logical unit.

See table 8 for the definition of the EXTENDED ADDRESS METHOD SPECIFIC field used when the well know logical unit extended address method is selected.

Table 8 - SCSI target function

Bit Byte	7	6	5	4	3	2	1	0
n-1	1	1	0	WELL KNOWN LOGICAL UNIT(000001b)				
n	W-LUN							

The w-LUN field identifies well known logical unit to be addressed. See table 9 for a list of well know addresses.

Table 9 - w-LUN field values

W-LUN	Name	Subclause
00h	Reserved	
01h	REPORT LUNs	4.3
02h	INTERMEDIATE PORT SERVER	4.4
03h	TARGET SERVER	4.5
04h-FFh	Reserved	

4.3 REPORT LUNs

The REPORT LUNs W-LUN shall only process the REPORT LUNs command (see SPC-3). The LUNs returned as the result of the REPORT LUNs command shall consist of a list of the requested logical units addressable through the SCSI target port that received the REPORT LUNs command.

Supported commands:

Table 10 - REPORT LUNs W-LUN commands

Command Name	Operation code	Type	Subclause
INQUIRY (need a different parameter list e.g., VPD=1 with new VPD page for W-LUNs)	12h	M	new
REPORT LUNs	A0h	M	SPC-3
REQUEST SENSE	03h	M	SPC-2
TEST UNIT READY	00h	M	SPC-2

Key: M = Command implementation is mandatory.

4.4 INTERMEDIATE PORT SERVER

The INTERMEDIATE PORT SERVER W-LUN shall only process commands associated with ports contained within a SCSI protocol device.

Intermediate SCSI initiator ports (see figure 1) are ports that occur in SCSI protocol devices and are transparent to the ULP.

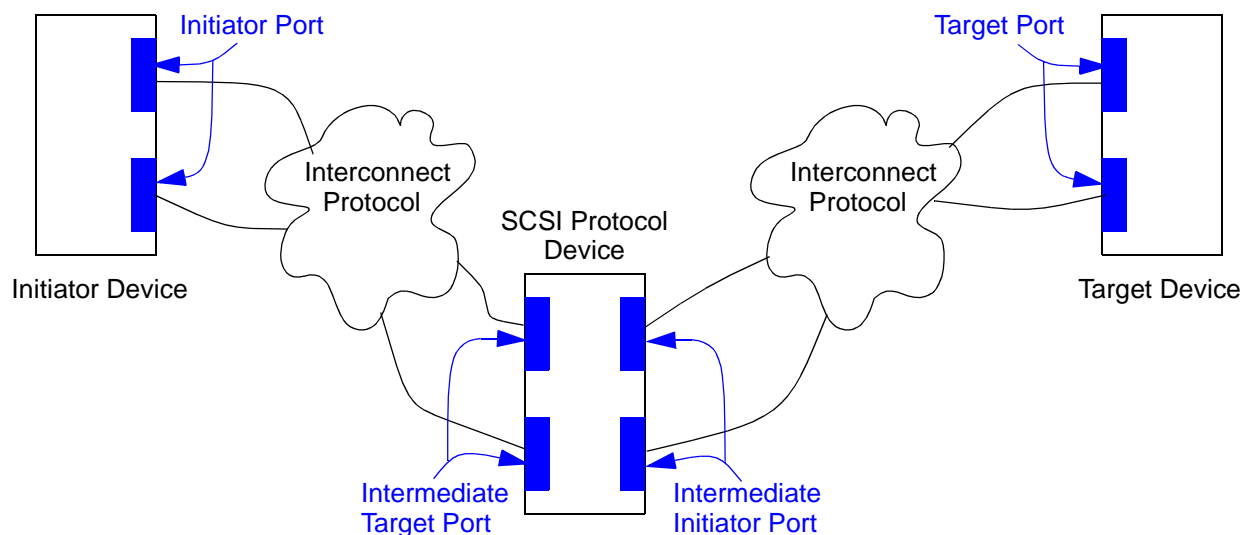

Figure 1 - Intermediate ports

Supported commands:

Table 11 - INTERMEDIATE PORT SERVER W-LUN commands

Command Name	Operation code	Type	Subclause
INQUIRY (need a different parameter list e.g., VPD=1 with new VPD page for W-LUNs)	12h	M	new
REPORT INTERMEDIATE INITIATOR PORT ASSOCIATIONS	TBD	M	4.4.1
REPORT INTERMEDIATE INITIATOR PORT TO LOGICAL UNIT ASSOCIATIONS	TBD	M	4.4.2
REPORT LUNS (only required to support reporting W-LUN option)	A0h	M	SPC-3
REQUEST SENSE	03h	M	SPC-2
TEST UNIT READY	00h	M	SPC-2
Key: M = Command implementation is mandatory.			

4.4.1 REPORT INTERMEDIATE INITIATOR PORT ASSOCIATIONS commands

The REPORT INTERMEDIATE INITIATOR PORT ASSOCIATIONS command shall report a list of intermediate initiator ports. The following information shall be returned for each intermediate initiator port:

- a) The SCSI protocol supported (e.g., Fibre Channel, InfiniBand (TM), iSCSI);
- b) type of port (e.g., FC NL_Port, FC N_Port, IB, Ethernet, Parallel SCSI);
- c) the SCSI initiator port identifier;
- d) the SCSI initiator port name; and
- e) a list of SCSI target ports that may be addressed.

The information returned for each addressed SCSI target port is:

- a) The SCSI target port identifier; and
- b) the SCSI target port name.

4.4.2 REPORT INTERMEDIATE INITIATOR PORT TO LOGICAL UNIT ASSOCIATIONS command

The REPORT INTERMEDIATE INITIATOR PORT TO LOGICAL UNIT ASSOCIATIONS command shall report a list of LUNs that are associated with each intermediate initiator port.

4.5 TARGET SERVER

The TARGET SERVER W-LUN manages all the ports and logical units within a SCSI target device.

Supported commands:

Table 12 - TARGET SERVER W-LUN commands

Command Name	Operation code	Type	Subclause
INQUIRY (need a different parameter list e.g., require VPD=1 with new VPD page for W-LUNs)	12h	M	new
REPORT TARGET PORT INFORMATION	TBD	M	4.5.1
REPORT LUNS	A0h	M	SPC-3
REQUEST SENSE	03h	M	SPC-2
TEST UNIT READY	00h	M	SPC-2
Key: M = Command implementation is mandatory.			

4.5.1 REPORT TARGET PORT INFORMATION command

The REPORT TARGET PORT INFORMATION command shall report a list of target ports contained within the target device that contains the addressed target port. The following information shall be returned for each target port:

- a) The SCSI protocol supported (e.g., Fibre Channel, InfiniBand (TM), iSCSI);
- b) type of port (e.g., FC NL_Port, FC N_Port, IB, Ethernet, Parallel SCSI);
- c) the SCSI target port identifier;
- d) the SCSI target port name; and
- e) a list of logical units that may be accessed through the SCSI target port.

The information returned for each logical unit:

- a) The LUN; and
- b) the logical unit name.

~~Reports the address of all source target ports and the destination target ports that are accessed through each source target port. In addition to the address each source port includes information on the type of network it is attached to (i.e., FC NL_Port, FC N_Port, IB, Ethernet, Parallel SCSI).~~

4.6 Other target function rules

If a SCSI target device receives a W-LUN and that W-LUN is not exist, a task manager shall follow the SCSI rules for selection of invalid logical units as defined in the SCSI Primary Commands-2 standard.

Editors Note 1 - GOP: Where are the SCSI rules of selection of an invalid logical unit?

Protocols should define a method to allow notification of a change to any of the reported information (e.e.g, AER would be one method).