

# Proposal for receiver “bandwidth” specifications

**Specifications are required on the dynamic response of SPI-4 receivers to protect against very “fast” receivers being implemented to meet the very tight timing budgets. SPI-4 receivers need to have a minimum level of protection against detecting small noise spikes.**

**Traditional frequency domain bandwidth specifications are not suitable for use with SCSI receivers because the receivers intrinsically do not operate in a linear region**

**The requirement is that the receiver system shall not detect pulses of certain amplitude and duration.**

**The remainder of this document is aimed at specifying the details of the pulses**

REQUIREMENTS (place in receiver section of Annex A):  
Receiving systems in SCSI devices capable of operation at Fast-160 shall not respond to the positive going or the negative going pulse train shown on the next slide when presented with the pulse train at the device connector for any signal.

The pulse trains shall have the following properties:

Pulse amplitude: any 0 to 60 mV  
Pulse width (@0V): any 0 to 0.2 ns  
Repetition time: any >12.5 ns  
Starting level: 60 mV above or below 0  
Slew rate : 400 to 1000 mV/ns

a.c. common mode = 0

d.c. common mode = 1.25 v

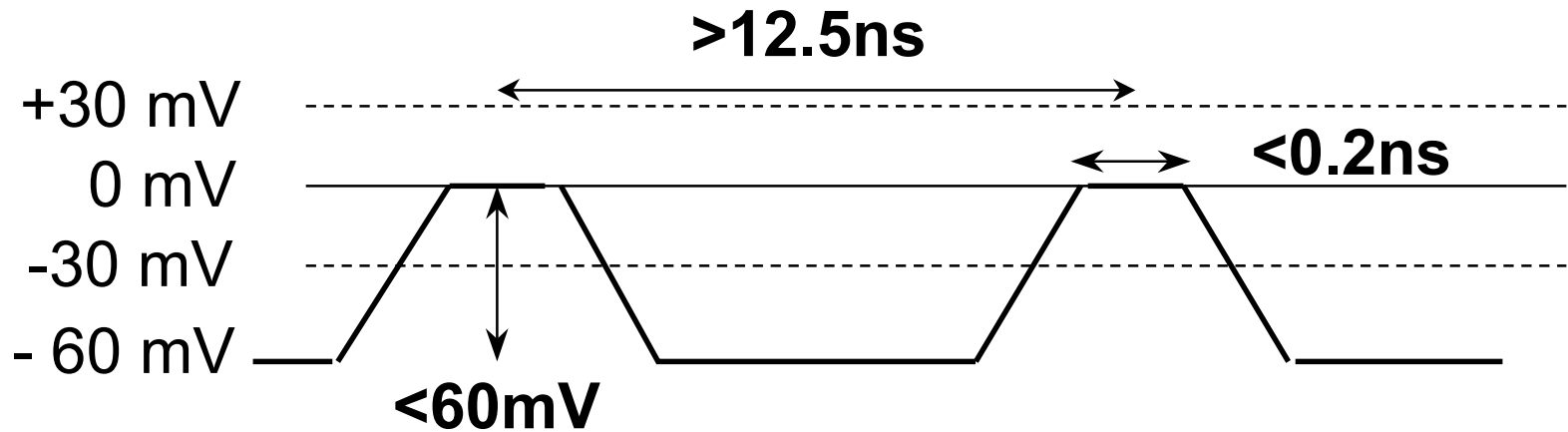

Positive going differential pulse train based at -60 mV

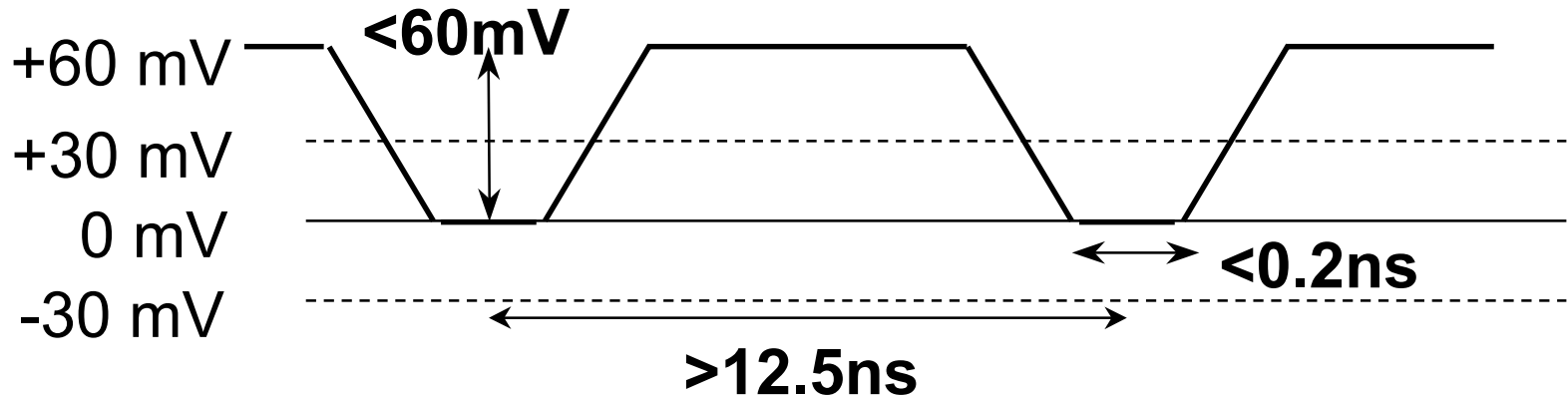

Negative going differential pulse train based at +60 mV