

## RECOMMENDATIONS FOR HARBOR PROJECT VIBRATION TESTING

Quantum Corporation  
Larry Witting, Mike Strzepa, Ken Kan, Charles deJesus  
4/27/99 ( Vib-harbor.doc)



99s008r0.pdf

Reference #1: "Computer Chassis Vibration Test Overview" by Tom Irvine  
Dated 2/28/99

The following are recommendations for improvements on the above referenced vibration test overview. The test set up consists of Ten, 1.6" or Fifteen , 1.0" Drive/Wrapper assemblies mounted into a Dock. See Fig 1 "Chassis with Hard Drive Units" on reference #1.

### RECOMMENDED IMPROVEMENTS:

- ROTATION – Establish a reference PES (Position Error Signal) by running a drive, seeking, outside the Dock on an agreed upon mounting method. Measure PES internally from the drive.

Run test per reference #1. The drive is powered and seeking producing rotational vibration about the Z axis. The vibration of the drive is calculated from data measured by placing accelerometers outside the drive and measuring linear and rotational acceleration. In addition to the 2 accelerometers shown in Ref #1, it is recommended that 2 additional accelerometers be placed on the side of the drive. This allows one to calculate X & Y translation as well as rotation.

Also it is recommended that the internal PES of the drive be measured directly. This direct measurement would be more meaningful because it would take the servo into account. The external vibration and internal PES measurement should be compared and a decision made on how to run the subsequent tests. Each drive manufacturer would have to provide a procedure for doing this.

Compare PES in the Dock to the reference drive and identify the effects of the Dock/Wrapper on the PES.

The location of the Drive/Wrapper assemblies in the Dock and whether the drive is operating or not, will have an effect on the other assemblies in terms of resonance. A simplified test location scheme for Ten 1.6" drives is described below. For 1.0" drives locations would be similar. It is assumed that the vibrational effects are symmetrical i.e. a positional configuration on one end is the same as the other.

"S" indicates the Source operating drive that produces the vibrational excitation.

"R" indicates the Recipient drive that receives the vibrational excitation.

"n" indicates slot is filled but drive is not operating.

OPERATING MODE: S AND R DRIVES ARE SEEKING

RECEIVER DRIVE AT END; SOURCE DRIVE VARIES POSITION:

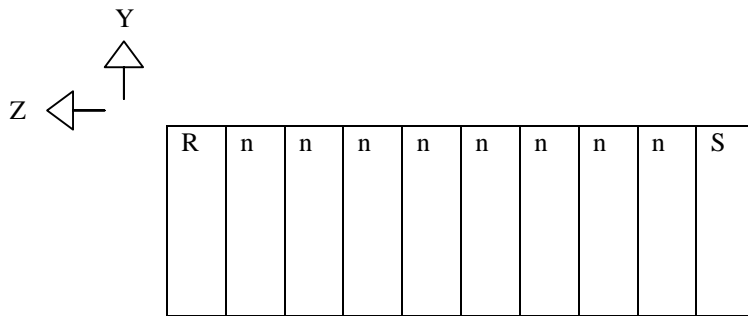
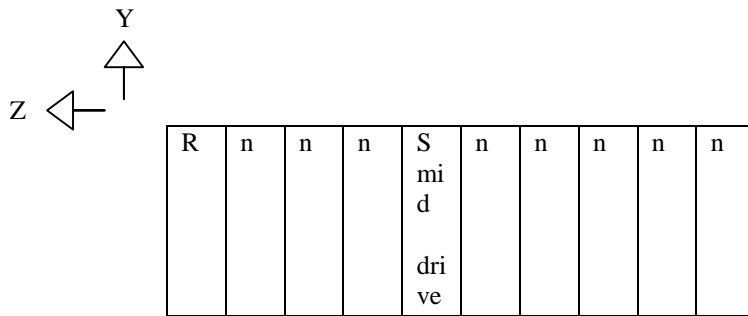
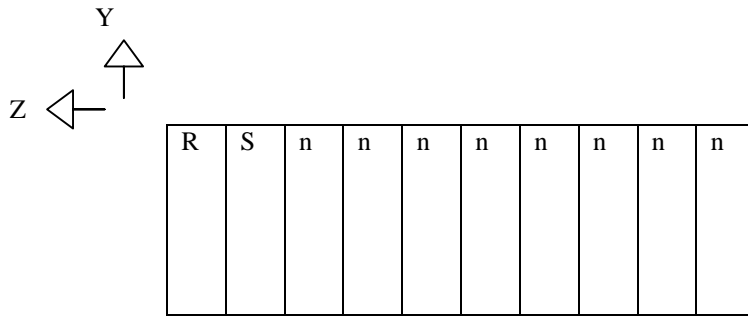

RECIPIENT DRIVE AT MIDDLE, SOURCE DRIVE VARIES POSITON:

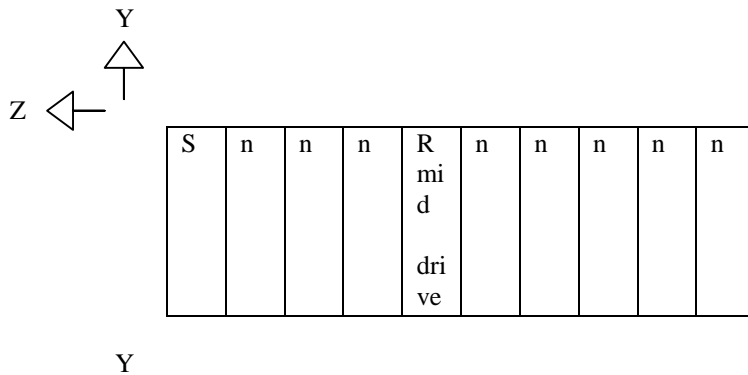

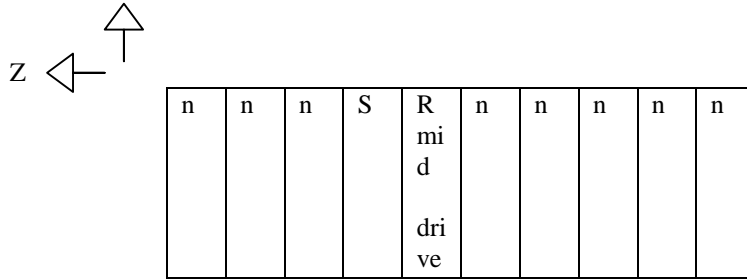

RECIPIENT DRIVE VARIES POSITION, ALL OTHERS ARE SOURCE DRIVES:

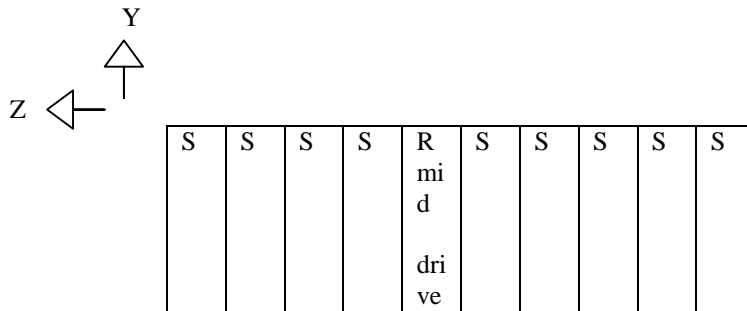
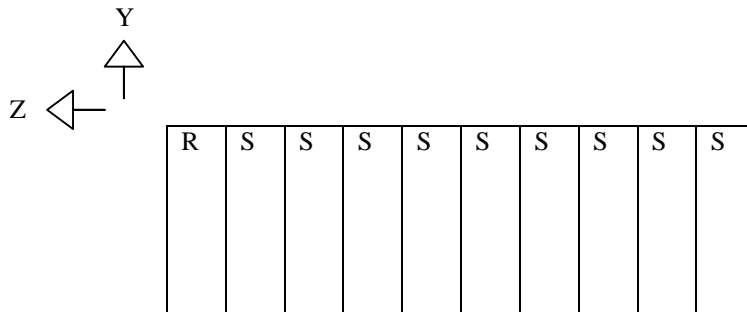

- TRANSLATION – The translation forces and accelerations along the X and Y axis should also be measured by placing the accelerometers appropriately in conjunction with the rotational measurements. The rotation and translations tests are the same and are run together. The external vibration translation measurements are again compared to the internal PES measurements.
- IDLE SYNC UP – When a number of drives are running together at constant speed (idling) slight variations will cause the frequencies to go in and out of synchronization.

Run similar tests as for ROTATION. Set up the drive combinations with the Recipient drives in the end and middle locations but all other drives are idling as Sources of vibration. Tests should be run long enough to allow resonances (beating) to occur. This could be one hour or more. Compare PES of R drives with the reference drive and identify the effects of sync-up.

- POST SEEK – Right after seeking, drives will react differently to resonant vibrations. This should also be tested.

Set up a drive for post seek and test outside the Wrapper on the agreed mounting. Use this post seek test as the reference.

Run the following post seek tests in the Dock and compare with the reference post seek drive:

OPERATING MODE: R DRIVES ARE IN POST SEEK STATE, OTHER DRIVES NOT OPERATING.

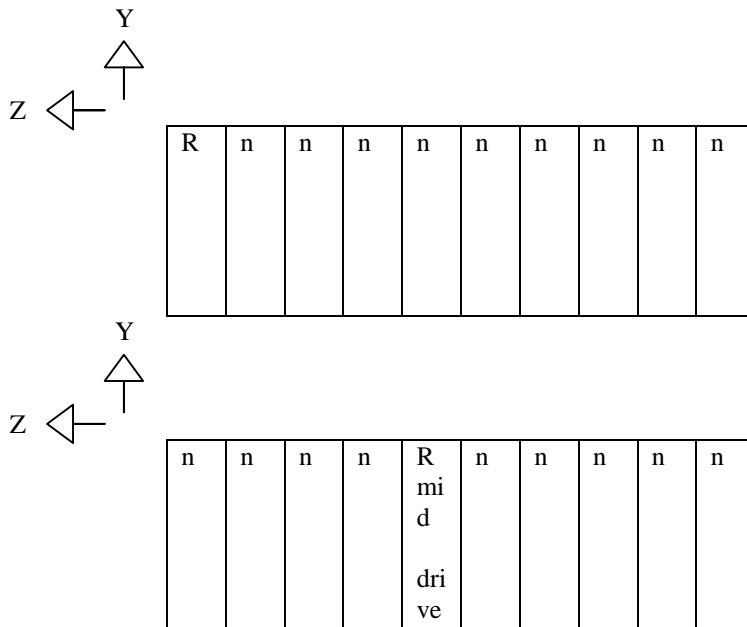

- INSERTION/REMOVAL – Test the effects of a typical operator inserting and removing a Drive/Wrapper assembly in the Dock. Establish typical shocks that an operator may deliver on all three axes.

OPERATING MODE: R DRIVE IS SEEKING, S DRIVE/WRAPPER IS INSERTED AND REMOVED, OTHER DRIVES NOT OPERATING

