November 9, 1998 Rev 4

Standard SCSI Harbor Wrapper/Dock rev4

Benjie Sun
Silicon Graphics Incorporated
2011 N. Shoreline Boulevard M/S 565
Mountain View, CA 94043
bsun@engr.sgi.com
(650) 933-5573

The following document relates to the specification of the carrying device which allows a SCSI storage device to interface with its computer chassis. The initiative is being developed as part of the SCSI Harbor Project (www.scsita.org/harbor/) within the SCSI Trade Association. A reflector has been set up to facilitate this project as well (harbor@scsita.org).

1.0 Introduction

The purpose of this document is to specify a common hard drive wrapper and dock design. The document includes key mechanical and electrical design requirements and explains the presently envisioned solution for those requirements.

1.1 Objective

To standardize a storage container capable of being used in a broad variety of storage peripherals (priority being disk drives) in order to lower the cost and increase the opportunity for storage component suppliers. The storage container must take into account the issues of new disk power requirements, faster spindle speeds, and tighter track pitches.

1.2 Benefits of Standard Design

1.3 Markets

The market spaces targeted for the standardized wrapper include:

- Standard High Volume Servers
- Mid Range Servers
- Entry level Servers
- Performance Workstations

1.4 Definition of Terms

Dock - The slot, compartment, or receptacle cavity within the chassis which receives the wrapper and which provides connectivity for the device.

EMI/ESD - Electromagnetic interference and electrostatic discharge.

Enclosure - The chassis or cabinet that contains one or more docks.

HDD - Hard disk drives

SCA-2 - Short for Single Connector Attachment, a type of disk drive connector that includes connection pins for the power cables as well as the data wires. The current version of SCA, called SCA-2, uses 80 pins and is frequently used for high-end SCSI devices.

SCSI - The Small Computer System Interface, SCSI is a set of evolving ANSI electronic parallel interface standards for attaching peripheral devices such as disk drives and printers to computers.

Wrapped assembly - The hard drive sheathed within and fastened to its wrapper.

Wrapper - The mechanical device to which a hard drive is fastened and which slides into a system chassis facilitating the proper electrical and mechanical connections between disk drive and backplane.

1.5 Related Documents

Specifications that must be used in conjunction with the Standard SCSI Wrapper/Dock specification include:

Standards	Specs
-----	-----
X3.302-xxxx	SPI-2 (SCSI Parallel Interface -2)
T10/1302	SPI-3 (SCSI Parallel Interface -3)
	SFF-T10/1143 EPI Enhanced Parallel Interface
	SFF-8046 80-pin SCA-2 Connector for SCSI Disk Drives
EIA-740	SFF-8300e 3 1/2" drive form factors (all of 83xx family)
	SFF-8301e 3 1/2" drive form factor dimensions
	SFF-8337e 3 1/2" drive w/SCA-2 Connector
EIA SP-3651A	SFF-8451 SCA-2 Unshielded Connections

Hard copies of ANSI and EIA standards or proposed ANSI standards may be purchased from the standards organization or from Global.

Global Engineering

303-792-2181

303-792-2192Fx

Electronic and/or hard copies of SFF Specifications are available by joining the SFF Committee as an Observer or Member.

SFF Committee

250-1752@mcimail.com

408-867-6630x303 408-741-1600Fx

NCITS (National Committee for Information Technology Standards) is the secretariat for the task groups doing interface standards (T10, T11, T13).

NCITS Secretariat jgales@itic.nw.dc.us

1250 Eye St. #200 202-737-8888

Washington DC 20005 202-638-4922Fx

Electronic copies of ANSI (NCITS) draft standards and SFF Specifications are available monthly from the CD_Access service offered by NCITS and ENDL.

CD_Access www.rahul.net/endl/

408-867-6630x303 408-867-2115Fx

2.0 Mechanical Specifications

This section defines the mechanical requirements for the product.

2.1 Wrapper

2.1.1 Wrapper Design

It is recommended that the wrapper shall be composed of a material with a minimum Modulus of Elasticity of 5,000,000 lb/in² and a minimum Shear Modulus of 2,000,000 lb/in². The vast majority of metals meet the above requirements. (Mark's handbook - Elastic Constants of Metals).

With the above elastic constant limits in mind, it is recommended that the body of the wrapper be composed of metal (aluminum, zinc, etc.). The advantages of using a metal wrapper include:

- better thermal properties (conductance through the wrapper)
- minimization of creep
- Stronger/stiffer wrapper better for vibration
- EMI containment
- ESD management

The wrapper shall accommodate 3.5 inch disk drives in both low profile (1 inch) and half height (1.6 inch) configurations. The wrapper and dock will be designed with the

goal of fitting ten 3.5 inch half height drives (without optional lids) into a standard 19 inch rack.

All wrappers will have the following features:

- SCA-2 connector opening
- Insert/removal guide scheme
- Shock isolation material
- EMI/ESD ground contacts
- Bezel
- Handle
- Optional PCB lid
- Anti-Rotational-Vibration Spring

Figures.....show an example of a possible implementation of the above mentioned features.

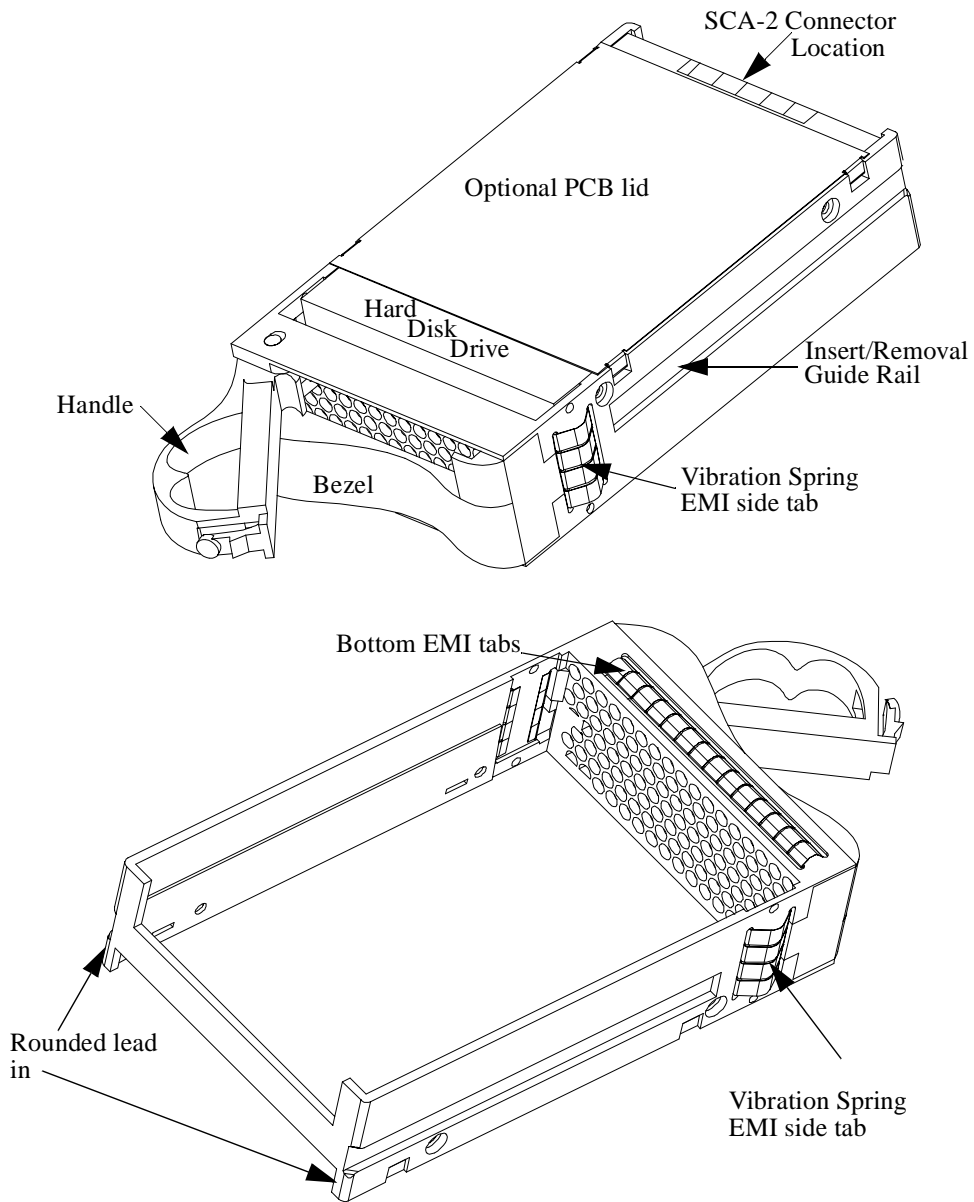

2.1.2 Wrapper Features

Wrapper Connector Location

An opening in the back face of the wrapper exists for the SCA-2 connector. The opening must allow ample air flow to pass over the wrapper and cool the components of the HDD.

Specify dimensions of opening or leave up to OEMs?

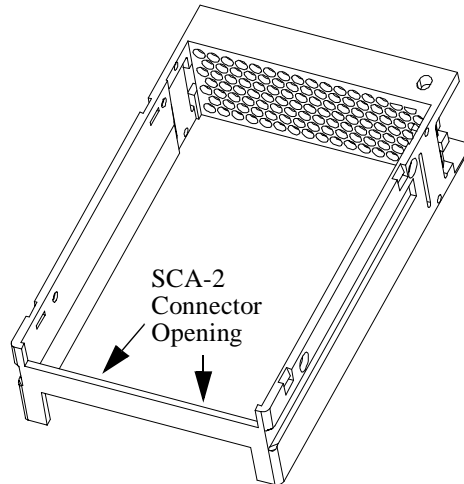

Guide Scheme

Some type of locating and guidance mechanism must be built into the sides of the wrapper to guide the wrapper as it is inserted into the dock. In addition to physically supporting the wrapped assembly, the guide provides rough alignment for the connector.

An example of this feature is shown in Figure.....

The figure below shows rectangular grooves measuring 5.25 x 0.40 x 0.10 (depth) in. A mating feature exists in the dock to accommodate the grooves. The section of the guide scheme that makes initial contact with the dock will be chamfered or rounded to facilitate initial engagement.

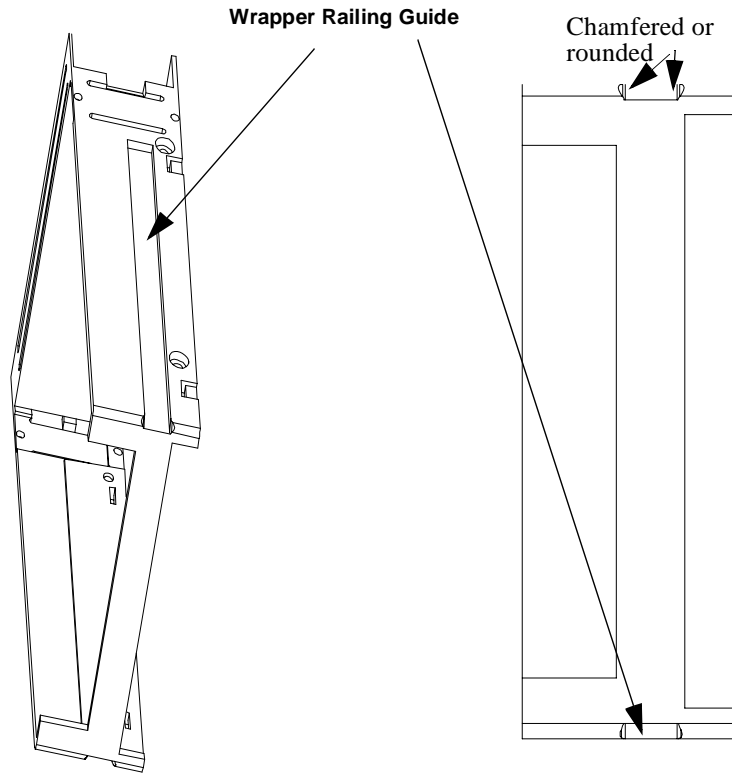

EMI/Ground Tabs

The system must maintain contact with the EMI tabs after full insertion of the SCA-2 connectors. Also, the system must make contact with the side EMI tabs for grounding purposes before the SCA-2 connectors begin mating.

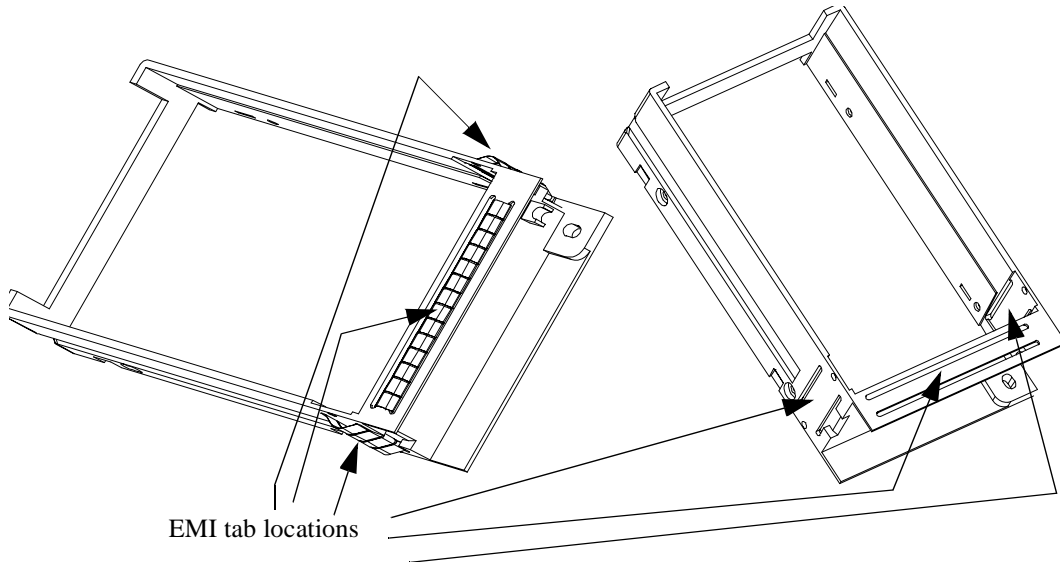

Shock Isolation Material

The wrapper shall have some type of dampening material affixed to top and bottom surfaces which serve to protect the contained HDD when the wrapped assembly is outside of its dock. The dampening material may simply be some sort of pressure sensitive adhesive-backed polyurethane products attached to the face of the wrapper.

The shock isolation should be mounted in such a way to protect the unit when tipped

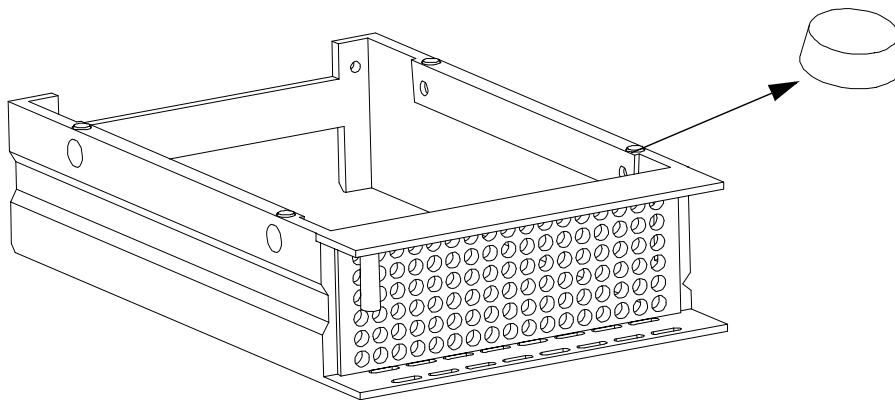

over from its long edge.

The maximum protrusion of the shock isolation material beyond the surface of the wrapper shall be 0.020 inches.

Bezels

This section specifies the front bezel for the wrapper. The bezel will snap into the wrapper at two pre-defined locations. The bezel has edges that match the width and height of the device and provides adequate air impedance.

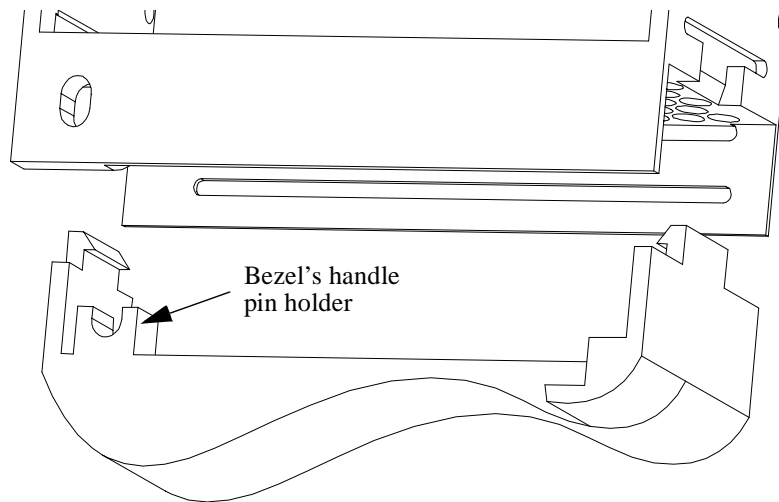
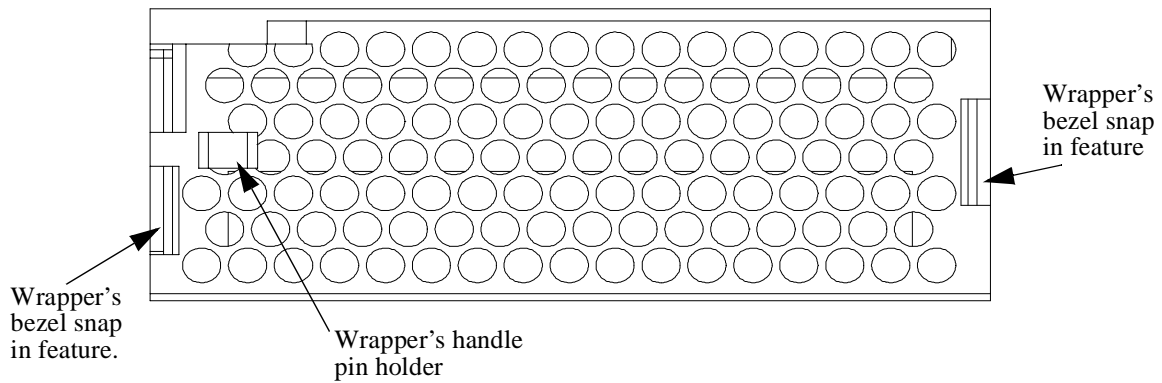

There exists a feature on the wrapper that mates with a feature on the bezel which are used to retain a cylindrical pin built into the handle.

The bezel can be customized, allowing an OEM to match the industrial design of devices with the system. The custom industrial design of the bezel can protrude past the edge of the wrapper, but the bezel perimeter must be maintained.

The bezel material is left up to the system OEM as long as the bezel is rated 94V-1.

Handle

The wrapper handle design provides several functional features. The handle itself pivots about one end and is used to slowly cam the wrapper in during insertion and out during removal. A feature on the handle provides a constant load between SCA-2 connector halves while taking up tolerances in the insertion direction.

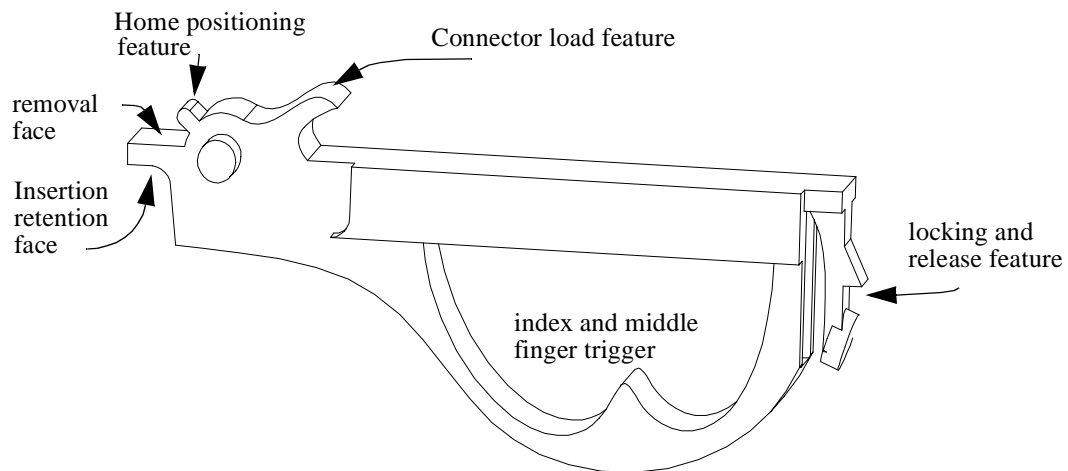

The slot at the front face of the wrapper allows the wrapped assembly to translate a somewhat variable distance in the insertion direction. The exact travel will depend upon the tolerance stack up of the individual wrapper and dock assemblies.

In the case of perfect assemblage (when all dimensions are at their nominal values), the pivot cylinder of the handle will lie at the center of the slot. In the case of imperfect assemblage the pivot point will translate (justify itself within the slot) accordingly.

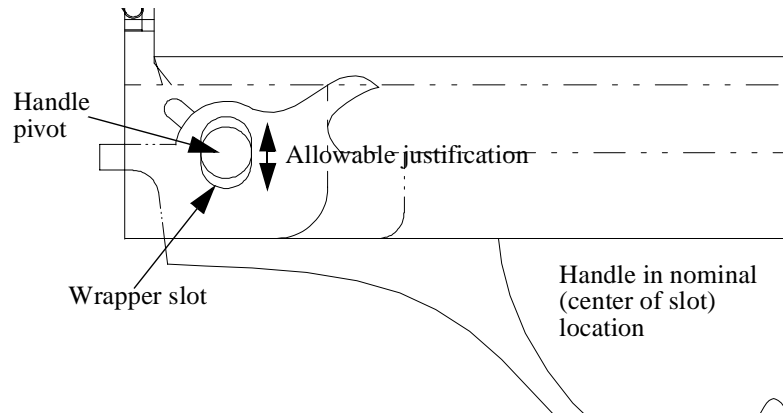

In the closed (as opposed to open) handle position, an extension of the handle acts as a leaf spring to maintain pressure at the connector halves. The plastic extension acts as a spring in the bent beam sense.

In the case when the tolerances put the pin at its most distal position from the backplane (in the figure below this would place the pin in the lowest position in the slot), the leaf spring will not be in deflection. In all other conditions the leaf spring will be in deflection, its reaction force placing the connectors under load.

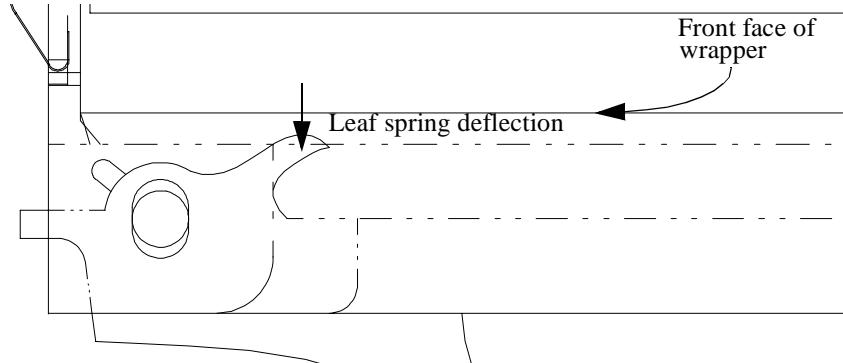

When the handle is opened a feature of the wrapper (a backstop essentially) prevents the handle from being opened beyond a 50 degree angle. Furthermore a second bump-like feature will help the handle find its home position where the pivot point is at its most distal location to the backplane. A consistent geometry is thereby ensured when the handle is in the fully opened position.

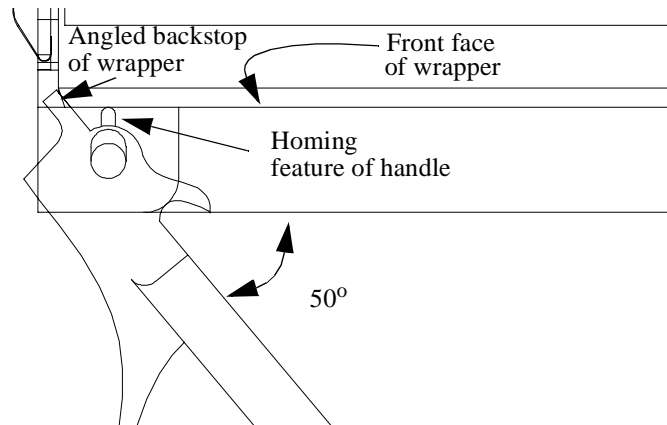

There also exists a feature on the handle which interacts with a feature of the bezel for latching and unlatching. In the figure below it would be assumed that the thumb would apply the force to deflect the latching mechanism while the middle and index fingers are inserted through the holes of the handle.

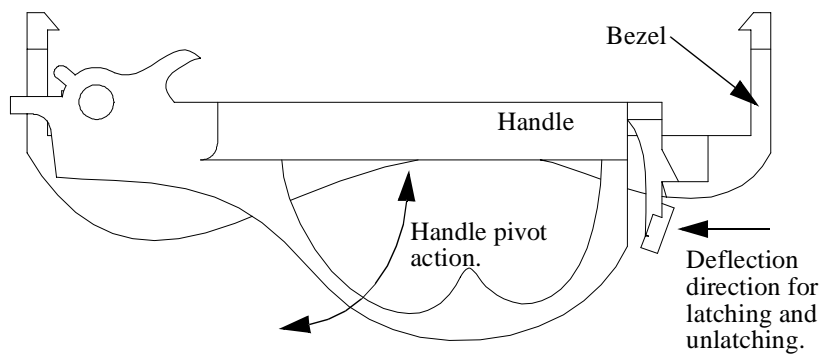

Removable lid

The wrapper will be designed to accept a removable lid, the purpose of which will be to protect the exposed PCB surface of the HDD.

The lid shall be a maximum of 0.020 inch thick. The exact attachment method of the lid to the wrapper shall be left up to the wrapper vendor. When the lid is attached, it shall not protrude beyond the side surfaces of the wrapper.

One possible implementation of a protective lid and its attachment to the host wrapper is shown in figure.....

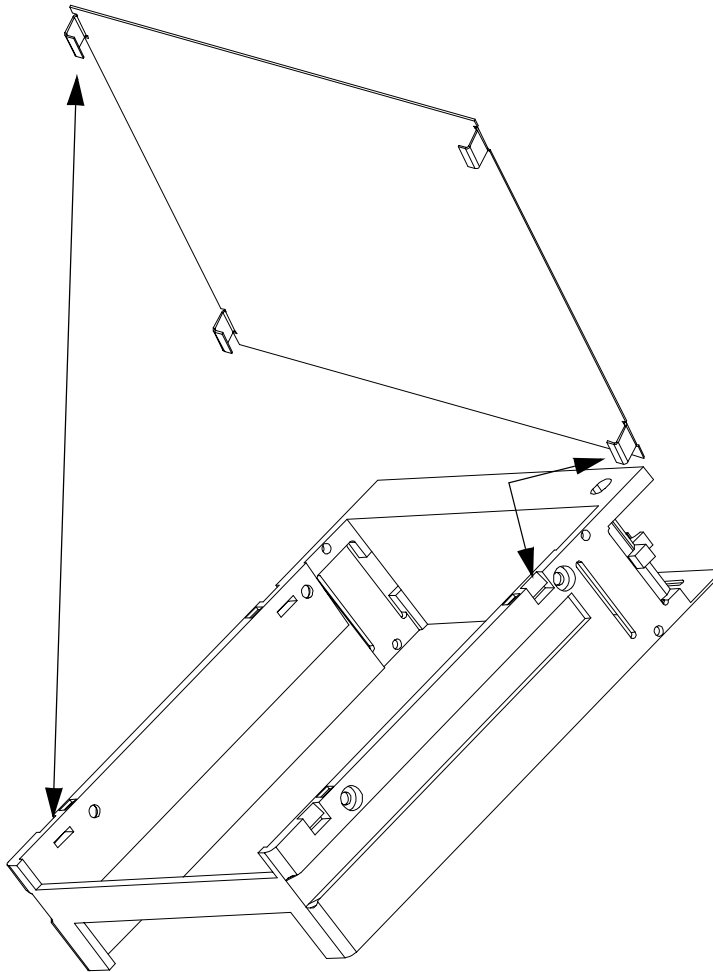

Rotational vibration leaf spring

(Single or Double-sided?)

A series of EMI metal tabs located along the side(s) of the wrapper near its front face will be used to take up the lateral tolerance between the wrapper and the dock. As the wrapper is inserted into its dock, the EMI springs deflect, effectively jamming the wrapper up against the opposite side rail. In doing so the unit is kept from experiencing excessive rotational vibration.

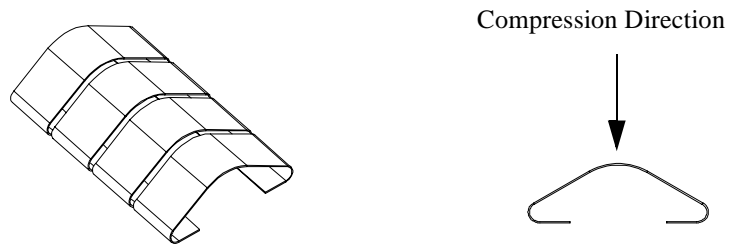

In operation, the vertical component of the spring's force on the wrapper must work with gravity whenever possible. Otherwise, the wrapped assembly might be left in a 'floating' situation, with gravity working against the spring, leaving the HDD susceptible to severe rotational vibration problems.

When the wrapped assembly lies in an orientation where no vertical spring force component exists, the tab orientation is left up to the system OEMs.

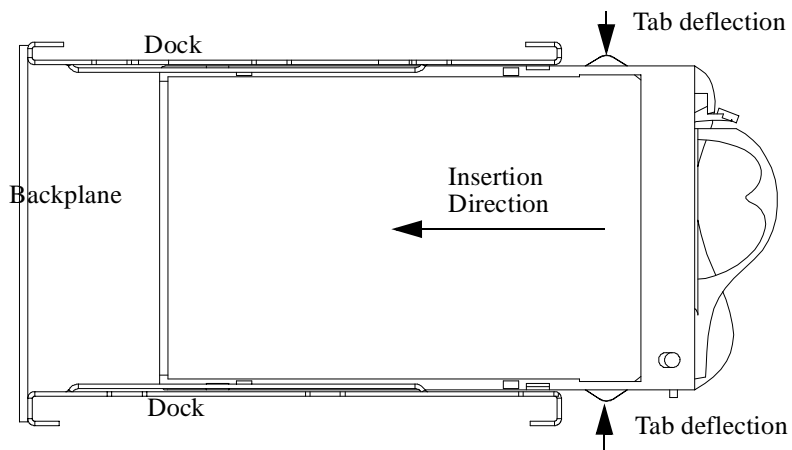

Wrapper to Drive Attachment

While the specific attachment method of the HDD to the wrapper is left up to the wrapper vendor, one possible implementation is shown in Fig.....

In the figure, the HDD is attached to the wrapper using four screws. As per SFF-8301 there are four mounting holes on the bottom and two on each side of the 3.5 inch HDD.

In this implementation, the two holes on each side is used to mount the HDD to the wrapper. (Although a disk vendor may provide for three positions per side, systems manufacturers may find that the hole located between the two specified holes is not in the same location relative to the other holes over a wide selection of drives.)

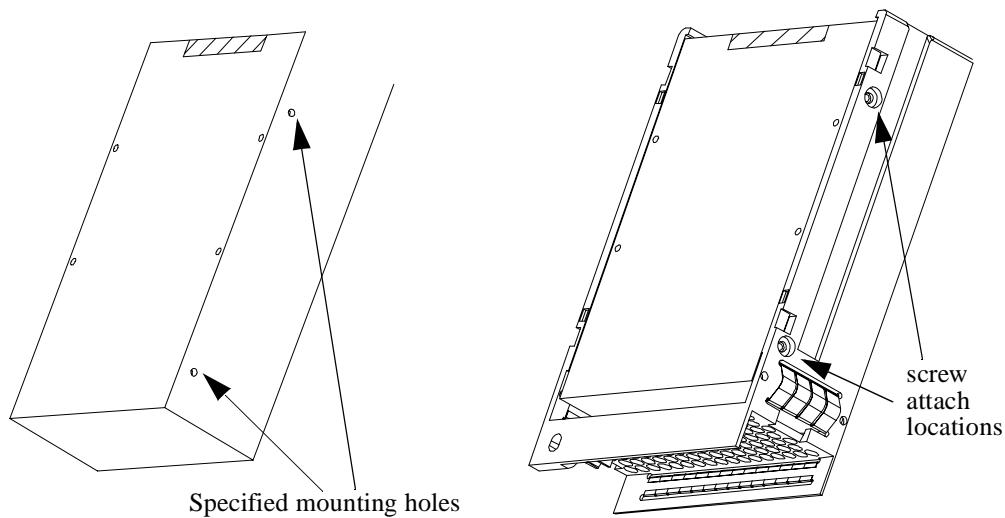

All screws and other hardware used in the assembly of a device must be recessed into the volume of the wrapper so there is no potential interference with the dock.

2.1.3 Wrapper/Connector Specifications

Refer to Pat M and Bob S.

2.1.4 Wrapper to Dock Attachment

The wrapped assembly is held in place within its dock at three locations.

- The SCA-2 connector supports its back end.

- The wrapper lever/dock slot interface restricts motion along the length of the unit such that it cannot back itself out.
- The spring leaf metal tab restricts motion along its width (both translational and rotational).

2.2 Dock

2.2.1 Dock Design

All docks will have the following features:

- SCA-2 connector receptacle
- Insert/removal guiding scheme
- Retention features

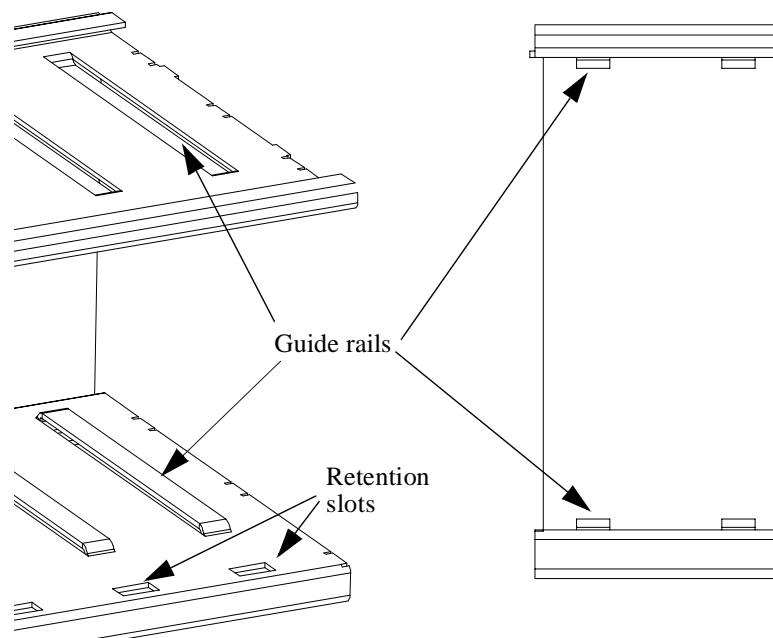

If the dock is to be constructed out of sheetmetal, it is suggested that the sheets be of minimum thickness, 0.060 in, to ensure the rigidity of the dock. (Also include suggested grade and Young's Modulus).

In order to maintain a rigid base in a multiple unit system, the dock should be reinforced by a bracket as shown in Fig.....or in a similar manner. The reinforcement bracket should be attached in such a manner where there are no protrusions on the dock surface along which the wrapper slides.

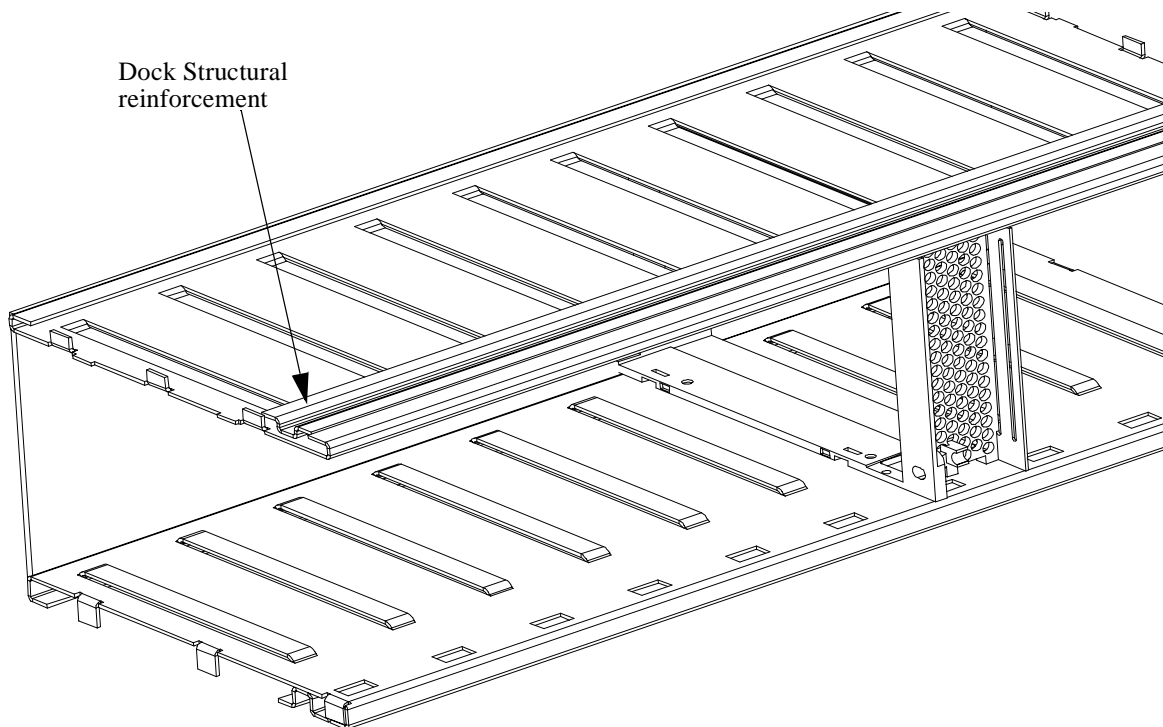

A slot in the dock will be used for insertion/retention as well as extraction purposes. The slot is to be located x.xxx inches from the backplane and x.xxx inches from the and will have dimensions of x.xxx X x.xxx inches as seen in the following diagram.

The front edge of the slot (the edge furthest from the backplane) will be used for insertion and retention purposes while the back edge (closest to the backplane) will be utilized during extraction.

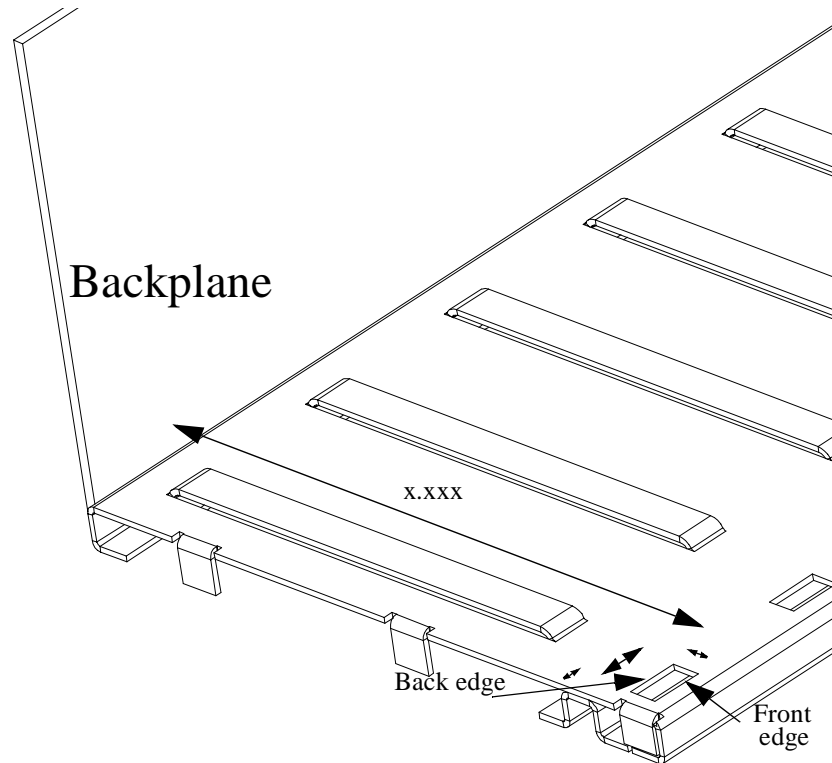

In general, the dock should be evenly anchored so as not to allow motion in the plane of the drive. Use of constrained layer damping may be required to quiet down significant modes or neighboring vibrations. Additional vibration isolation may be needed if significant vibration transmission occurs from chassis to dock.

2.2.2 Connector/Dock Specifications

A means of accurately mounting the SCA-2 connector must be provided to ensure appropriate presentation of the receptacle to the device. When designing the placement of the connector receptacle in the dock, the overall tolerance stackup needs to include the tolerance limits of the connector wipe. This needs to include such things as the coplanarity and mounting of the PCB.

2.3 Mechanical Insertion and Removal

The handle (part of the wrapper) is used to overcome the friction at the point of connector engagement/disengagement during insertion and removal. The camming action provides for a slow yet sure connection process.

2.3.1 Insertion

In order to insert the wrapper into the dock the handle must be in an unlocked and fully opened position. Otherwise the engagement tip of the lever will interfere with the sheet metal of the dock, keeping the wrapper from being inserted further.

With the guide rails of the dock serving as initial alignment, the wrapped assembly should slide easily into the dock until the side springs deflect to take up the lateral tolerance. At this point additional pressure can be applied to the bezel face to further insert the wrapped assembly.

At some point the handle will begin to two halves of the SCA-2 connector (the hard drive half and the PCB half) are nearly mated.

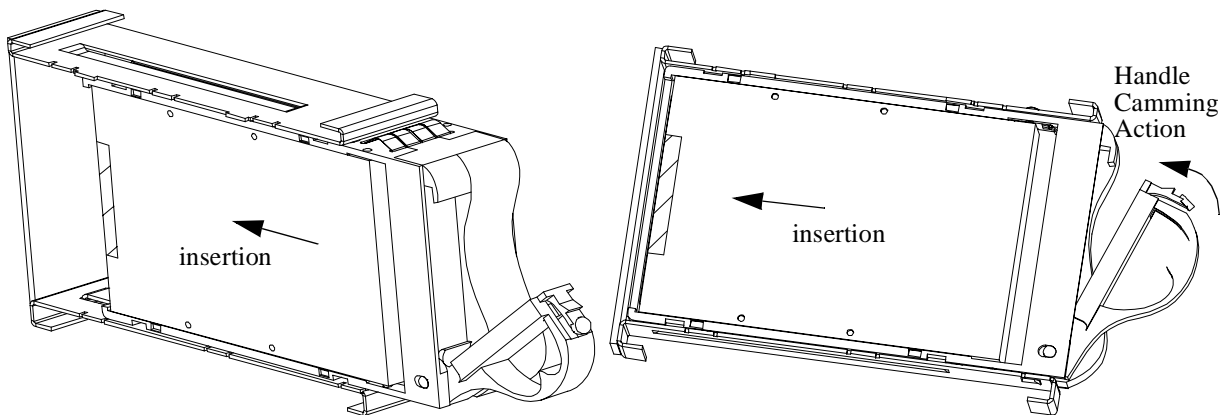

At this point the open lever will be in a position to engage a rectangular slot which has been cut out of the dock. As the lever is pushed in, the lever's tip engages this slot and fully seats the wrapped device into the dock, completely mating the SCA-2 connector halves.

During this pivoting action, an extension of the handle presses up against the front metal face of the wrapper, deflecting further and further as the lever is closed.

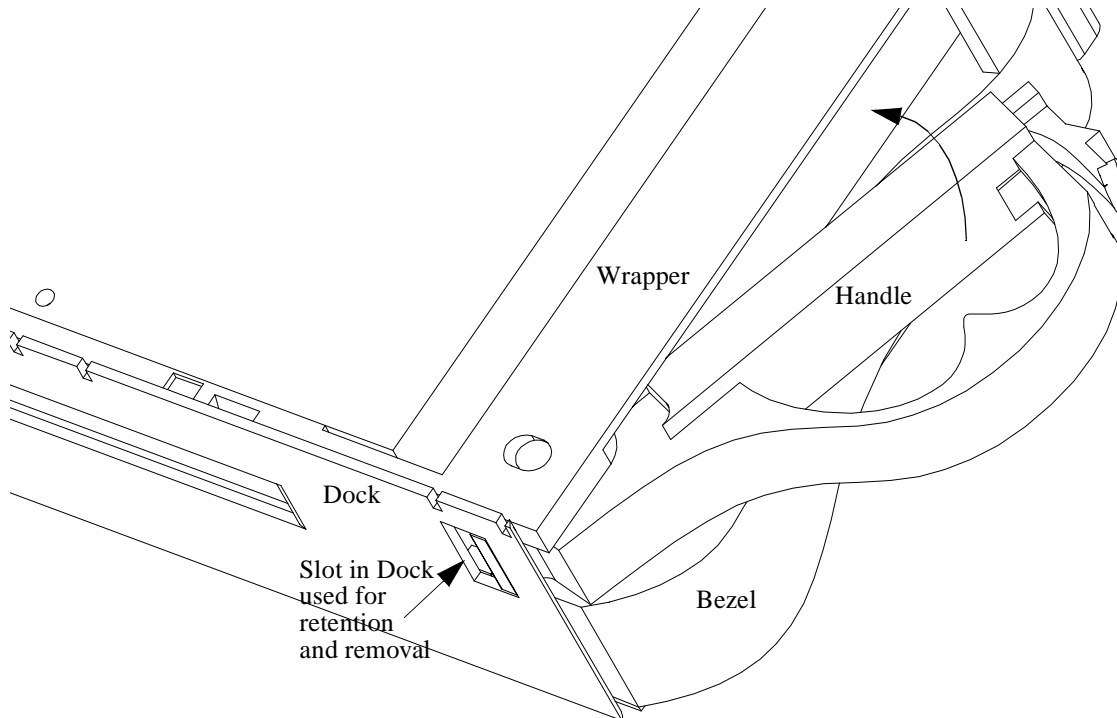

As the connector halves are mated the lever locks itself in this closed position by engaging part of the bezel. The retention mechanism specifics for how the lever locks into the wrapper are left to the system OEMs. The bending of the built in plastic leaf spring feature of the lever ensures a constant positive force on the connector.

The retention features must support a minimum of 35 pounds or 40 g's (using the device's weight) whichever is more.

2.3.2 Removal:

To remove a given wrapped assembly the major frictional forces between the wrapper and dock (between the SCA-2 connector halves) must again be overcome, this time by rotating the handle out.

The handle must first be unlocked (mechanism again left up to the system OEMs) before the handle can pivot out. When unlocked the deflected plastic feature of the lever releases its stored energy to help in the removal process.

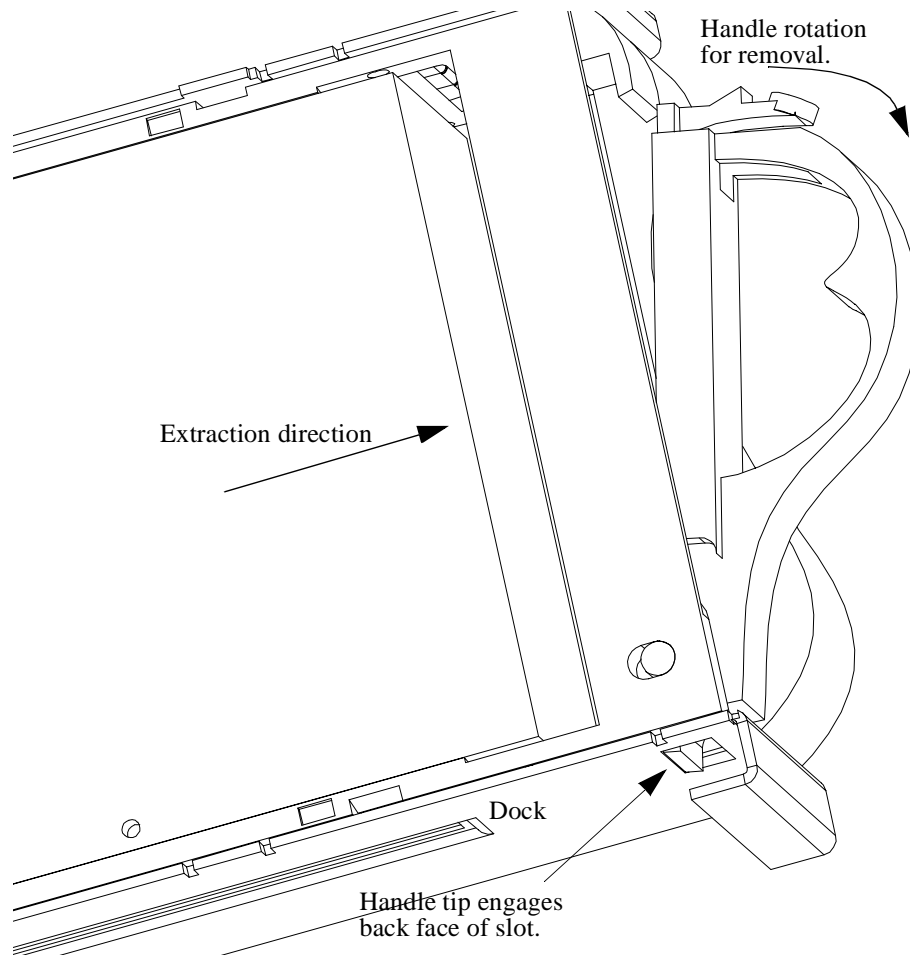

The tip of the lever arm now engages the back side of the slot in the dock such that the lever's mechanical advantage is used to slowly separate the SCA-2 connector halves.

Before the wrapped assembly is fully extracted, the handle should be relocked into its bezel for a more secure holding and handling mechanism.

2.4 Keying Mechanism

The shape of the SCA-2 connector ensures that the wrapper cannot be improperly fully inserted. Furthermore, the design of the railing system may be done in such a way as to ensure initial correct insertion orientation. By using different rail cross-sectional geometries, the wrapper cannot be inserted backwards into its dock. Moreover, the handle will not be able to locate the slot of the dock if inserted backwards.

Dock

Wrapper

2.5 Locking Mechanism

The wrapper provides a feature which can be utilized to individually lock each wrapped assembly into its dock. The exact implementation of the feature for locking purposes is left up to the individual system OEMs.

2.6 EMI

Wrapper contains EMC shield.

The disk drive EMI emissions shall be no worse when sheathed in the wrapper as compared to its bare emissions.

2.6.1 Contact Points

2.6.2 Materials

2.6.3 Level of Approval

2.6.4 Dock Features & Options

2.7 ESD Management

SCSI harbor does not define any specific requirements relating to ESD management. It is the responsibility of the implementer and the user to ensure adequate protection against excessive voltage and excessive spark discharge radiation during wrapper insertion and removal. The wrapped assembly should in general provide grounding between device and dock before the SCA-2 connector halves mate such that the electrostatic discharge does not occur through the connector. There may be conducting areas on the wrapper and/or device where the potential of the handler or handling mechanism may be transferred directly to the device circuitry in the wrapper.

In the final service position a low impedance high frequency path to the dock ground is desirable to avoid transferring static charge to the internal circuitry of the device in the wrapper. During the initial parts of the insertion or removal of the wrapper from the dock it is desirable to have high impedance paths to the dock ground so that the voltage equalization may happen relatively slowly and without spark discharge radiation.

2.7.1 Material Compatibility (from Device Bay)

Material selected for the mating surfaces of the ground clips must be compatible to prevent galvanic corrosion. The base alloy of the mating surfaces on the device and the system grounding clips must be within 0.3V, using the type of steel to be specified later.

2.7.2 Ground Contact Resistance (from Device Bay)

The initial contact resistance between the device and the chassis ground must not exceed 0.250Ω and must not degrade during the life of the SCA-2 connector by more than 0.020Ω from its initial resistance measurement.

2.8 Insertion Sequence/Events

1. Wrapper and dock guide rails align.
2. If another wrapper exists to the left of the inserting wrapper, the EMI/ESD tabs of adjacent wrapper contact the inserting wrapper's PCB cover. (top/bottom?)
3. The anti-vibration leaf spring contacts dock (electrostatic discharge assured).
4. EMI/ESD tabs contact adjacent (right) wrapper.
5. Lever tip engages slot of the dock.
6. SCA-2 connector halves are mated as the lever is pivoted shut.

2.9 Removal Sequence/Events

1. Lever is pivoted open, lever tip engages back side of slot.
2. SCA-2 connector halves are separated.
3. EMI/ESD tabs separate from the adjacent (right) wrapper.
4. If another wrapper exists to the left of the extracting wrapper, the EMI/ESD tabs of the adjacent wrapper contact the extracting wrapper's PCB cover.
5. The anti-vibration leaf spring moves past the dock.
6. The wrapper is pulled out of the dock.

2.10 Low-Profile Version

One possible implementation of the above features within a 1" high form factor might be the following:

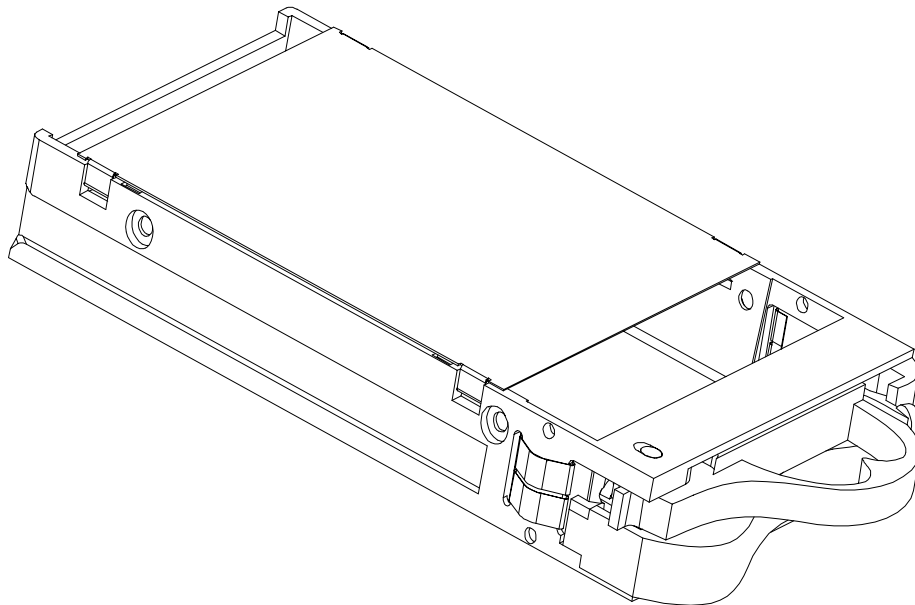

2.11 Shock and Vibration

See pending work from IDEMA S&V Spec committee

All vibration and shock testing should occur with the drive mounted in the wrapper. For non-operating testing the wrapper assembly is then fixtured to the input device with the input power applied directly to the wrapper. For operating testing the wrapper is inserted into its dock and the enclosure is fixtured to the input device with the input power applied directly to the enclosure/chassis.

2.11.1 Operating Shock

The wrapped assembly meets the following criteria.

- No data loss with 10G 11ms half sine shock pulse
- No data loss with 65G 2msec half sine shock pulse

Ten shock pulses at each input level are applied in both the positive and negative directions of the three mutually perpendicular axes (one axis at a time) with a minimum of 30 seconds delay between shock pulses.

2.11.2 Non-Operating Shock

The wrapped assembly withstands the following half-sine shock pulses.

- No data loss with 75G 11msec
- No data loss with 175G 2msec

Ten shock pulses at each input level are applied in both the positive and negative directions of the three mutually perpendicular axes (one axis at a time) with a minimum of 30 seconds delay between shock pulses.

2.11.3 Tip over test

The wrapped assembly shall withstand the shock of being tipped over about its long axis without sustaining functional damage.

2.11.4 Non-operational Rotational Shock

The wrapped assembly withstands the following rotational shock.

- No data loss with 18,000 rad/sec² rotational shock applied around the axis of actuator pivot.

2.11.5 Operating Vibration

Random Vibration.

The wrapped assembly is designed to operate without unrecoverable errors while being subjected to the following vibration levels.

The Measurements are carried out during 30 minutes of random vibration using the power spectral density (PSD) levels as follows.

TABLE 1.

Random Vibration PSD Profile Breakpoints (Operating)									
Hz	5	17	45	48	62	65	150	200	500
Horizontal vibration x10 ⁻³ [G ² /Hz]	0.02	1.1	1.1	8.0	8.0	1.0	1.0	0.5	0.5
Vertical vibration x10 ⁻³ [G ² /Hz]	0.02	1.1	1.1	8.0	8.0	1.0	1.0	0.5	0.5

Overall RMS (Root Mean Square) level of horizontal vibration is 0.67G.

Overall RMS (root mean square) level of vertical vibration is 0.56G.

Swept Sine Vibration.

The wrapped assembly will meet the criteria shown below while operating in respective conditions.

- No errors - 0.5G 0-peak, 5-300-5 Hz sine wave, 0.5 octaves/min sweep rate with 3 minute dwells at 2 major resonances.
- No data loss - 1.0G 0-peak, 5-300-5 Hz sine wave, 0.5 octaves/in sweep rate with 3 minute dwells at 2 major resonances.

2.11.6 Non-Operating Vibration

The drive does not sustain permanent damage or loss of recorded data after being subjected to the environment described below.

Random Vibration.

The test consists of a random vibration applied for each of three mutually perpendicular axes with the time duration of 10 minutes per axis. The PSD levels for the test simulates the shipping and relocation environments.

Random Vibration PSD Profile Breakpoints (Non-Operating)							
Hz	2	4	8	40	55	70	200
$\times 10^{-3}$ [G ² /Hz]	1	30	30	3	10	1.0	1

Overall RMS (Root Mean Square) level of vibration is 1.04G.

Swept Sine Vibration.

- 2 G (zero to peak), 5 to 500 to 5 Hz sine wave
- 0.5 octaves/min sweep rate
- 3 minutes dwell at two major resonances

2.11.7 Towards and from

2.11.8 Transfer function

2.11.9 Rotational Vibration

A major problem for the new generation of high performance hard disk drives (10krpm and up) occurs when the rotational vibration of one drive induces performance loss in neighboring drives. The faster drives with tighter track pitches and lower flying heads are more susceptible to in plane yaw rotation about the spindle axis.

A set of metrics must be developed to quantify the rotational vibration in the form of numerical targets for acceptable energy levels measured at the drive in the system environment.

There are two main sources of operational vibration problems for hard-mounted drives:

1. Seek-related rotational vibration caused by the voice coil motor rotating the head mechanism to the proper location above the disks. Random seeks will in turn cause random rotational oscillations with broad frequency content. The transmission path causes in-plane oscillation of the drive’s dock as well as the neighboring docks and drives.
2. Imbalance related rotational vibration from either a static or dynamic imbalance in the disk pack.

2.11.10 Wrapper/Dock Interaction

2.12 Thermal Management

Cooling of the disk drives will be accomplished by convective airflow. This will occur primarily directly from the drive, to a lesser extent after conduction of the heat from the drive to the Wrapper, and to an even smaller degree, from the enclosure or chassis that contains the drives. The amount of cooling from each of the above components of the system, will depend on the materials used and the amount of direct contact for the heat flow to travel. For adequate air flow to be maintained, it is likely that all of the drive slots in a chassis will need to be occupied. In some cases, these could be empty Wrappers if the chassis is not fully populated with drives. In lieu of the use of empty wrappers, the chassis designers may elect to incorporate a device in the chassis block the air flow when the wrapper is not inserted.

The wrapped assembly must allow for cooling of the electronics and head and disk assembly (HDA). Forced convection via fans will pass air through holes in the back-plane to facilitate the cooling of the unit. It is recommended that the air flow be directed front to back over the wrapped hard drive assemblies where the back is defined to be the connector end of the device.

The metal wrapper will act as a heatsink for the hard drive with conduction occurring along the four screws used to attach the hard drive to the wrapper. The thermal capacitance and increased surface area of the cast metal wrapper will help to alleviate the heat buildup.

2.12.1 Max Power

2.12.2 Peak Power

The operating conditions for the device are as follows:

Description	Value
Air Temperature	+5C to +35C up to 5000 ft
Air Temperature	+5C to +30C, 5000 ft to 10,000 ft
Humidity	10% to 95% non-condensing

The non-operating conditions for the device are as follows:

Description	Value
Temperature	-40C to +60C
Humidity	10% to 90% non-condensing
Altitude	-1,000 ft to +40,000 ft

2.12.3 Case Temperature

2.13 Acoustics (from DeviceBay)

All acoustic measurements of a device outside the system must be made in compliance with ISO 7779. Operating conditions for the device during measurements are given in ECMA 074 Dec.96 edition which is available at www.ecma.ch.

3.0 Connector Specifications

Reference SCA-2 (PAT M.)

4.0 Visual Status Indicators

4.1 LED's

There will be two LED indicator lights per drive for "Drive Activity" brought to the front of the Drive Carrier via light-pipes. The light pipes will be located in the dock. Current for the LED shall be supplied by the drive via the SCA-2 as appropriate.

5.0 Hot Plugging

SCSI harbor assumes that the contact position sequencing properties of the SCA-2 connector satisfies the basic electrical and contact sequencing properties for hot plugging of SCSI devices.

The mechanical shock associated with insertion and removal is minimized by using the retention cam for the final mating and initial demating of the SCA-2 connector. Care should be exercised during the initial insertion of the wrapper into the dock to avoid

bumping the dock with the wrapper. The cam lever on the retention mechanism should be opened during the insertion to prevent shock to the retention mechanism, the dock case, and the devices in the dock that may be operating.

Power stability, device shutdown, device initialization, locking/unlocking signals on the retention cam, and other properties associated with device hot plugging are not part of this specification.

6.0 Handling

Refer to **IDEMA Disk Drive Handling Training Manual**. The manual is designed to help companies reduce their handling damage related costs. It is written with the expectation that the disk drives will be shipped and handled both in bulk and individually. The presence of a wrapper on the drive may add some protection, but essentially the same guidelines will apply.

This manual, which includes three presentations to help your company control handling damage. These sections, Management Overview, Disk Drive Handler's Overview, and Process Engineering Overview, include color foils, detailed presenter notes, and a disk drive handling cost estimator disk. To order the manual or get more information, please contact IDEMA at their website, <http://www.idema.com/handling.htm>.